

MODEL 4900 FRONT FOLD PLANTER OPERATOR MANUAL

M0247-01

Rev. 2/19

This manual is applicable to: Model 4900 Forward Folding Planters
2013-2018 Production

Record the model number and serial number of your planter along with date purchased:

Model Number _____ 4900 _____

Serial Number _____

Date Purchased _____

Monitor Serial Number _____
Measured Pulses Per Mile/Km (Radar Distance Sensor) _____
Measured Pulses Per Mile/Km (Magnetic Distance Sensor) _____

SERIAL NUMBER

The serial number plate is located on the planter frame as shown below. The serial number provides important information about your planter and is needed to obtain correct replacement parts. Always provide model number and serial number to your Kinze Dealer when ordering parts or when contacting Kinze Manufacturing, Inc.



Serial Number Plate Location

*Kinze® and the Kinze® logo are registered trademarks of Kinze Manufacturing, Inc.
Vacuum Meter, Electric Drive, and Flip Axle have patents pending.*

This page intentionally left blank.

TO THE DEALER

Predelivery service includes assembly, lubrication, adjustment and test. This service helps ensure planter is delivered to retail customer/end user ready for field use.

PREDELIVERY CHECKLIST

Use the following checklist after planter is completely assembled. Check off each item as it is found satisfactory or after proper adjustment is made.

- Row units properly spaced and optional attachments correctly assembled.
- Row marker assemblies installed and adjusted at each end of the planter.
- Vacuum meter and bulk fill components properly installed (as applicable).
- All grease fittings in place and lubricated.
- All working parts move freely, bolts are tight, and cotter pins are spread.
- Check all drive chains for proper tension and alignment.
- Check for oil leaks and proper hydraulic operation.
- Hydraulic hoses correctly routed to prevent damage.
- Inflate tires to specified air pressure and torque wheel lug bolts and lug nuts as specified in the Operator Manual.
- All safety decals correctly located and legible. Replace if damaged.
- All reflective decals and SMV sign correctly located and visible when the planter is in transport position.
- Safety/warning lights correctly installed and working properly.
- Paint all parts scratched during shipment or assembly.
- All safety lockup devices on the planter and correctly located.
- Auxiliary safety chain properly installed and hardware torqued to specification.
- Vacuum fan PTO-driven pump correctly attached to tractor. Oil reservoir filled to capacity and system inspected for leaks (If applicable).

Planter has been thoroughly checked and to the best of my knowledge is ready for delivery to the customer.

(Signature of Set-Up Person/Dealer Name/Date)

OWNER REGISTER

Name _____ Delivery Date _____

Street Address _____ Model No. 4900 Serial No. _____

City, State/Province _____ Dealer Name _____

ZIP/Postal Code _____ Dealer No. _____

DELIVERY CHECKLIST

Use the following checklist at time planter is delivered as a reminder of very important information which should be conveyed to retail customer/end user. Check off each item as it is fully explained.

- Check proper operation of vacuum fan, bulk fill fan, and PTO-driven pump (If applicable) with tractor used with planter.
- Life expectancy of this or any other machine is dependent on regular lubrication as directed in the Operator Manual.
- All applicable safety precautions.
- Along with retail customer/end user, check reflective decals and SMV sign are clearly visible with planter in transport position and attached to tractor. Check safety/warning lights are in working condition. Tell retail customer/end user to check federal, state/provincial, and local regulations before towing or transporting on a road or highway.
- Give Operator Manual, Parts Manual, and all Instruction Sheets to retail customer/end user and explain all operating adjustments.
- Read warranty to retail customer/end user.
- Complete Warranty and Delivery Report form.

To the best of my knowledge this machine has been delivered ready for field use and customer has been fully informed as to proper care and operation.

(Signature of Delivery Person/Dealer Name/Date)

AFTER DELIVERY CHECKLIST

The following is a list of items we suggest to check during the first season of use of the equipment.

- Check planter performance with retail customer/end user.
- Check performance of vacuum meter or mechanical seed metering system with retail customer/end user.
- Review importance of proper maintenance and adherence to all safety precautions with retail customer/end user.
- Check for parts that may need to be adjusted or replaced.
- Check all safety decals, reflective decals, and SMV sign are correctly located as shown in the Parts Manual and that decals are legible. Replace if damaged or missing.
- Check safety/warning lights are working properly.

(Signature of Follow-Up Person/Dealer Name/Date)

**All registrations must be submitted online at "business.kinze.com" within 5 business days of delivery.
Retain a copy of this form for auditing purposes.**

Tear Along Perforation



MACHINE OPERATION

Row Marker Safety Lockup	2-1
Transport Axle Cylinder Safety Lockup	2-2
Drawbar Hitch Lockup (Option)	2-3
2-Point Hitch Option	2-4
Initial Planter Preparation	2-5
Tractor Requirements	2-7
Vacuum Meter Tractor Mounted PTO Pump and Planter Mounted Hydraulics	2-7
Tractor Preparation and Hookup	2-8
Cylinder Information	2-11
Hydraulic Hose Information	2-15
Transporting Planter	2-25
Level Planter	2-26
Hydraulic Seed Rate Drive	2-26
Hall Effect Sensor (Hydraulic Drive Only)	2-26
Jump Start Sensor	2-27
Field Operation	2-27
Transport to Field Sequence Using ISOBUS	2-28
Transport to Field Sequence Using Control Box	2-33
Transport to Field Sequence Using Advanced ISOBUS Control Box	2-38
Field to Transport Sequence Using ISOBUS	2-42
Field to Transport Sequence Using Control Box	2-47
Field to Transport Sequence Using Advanced ISOBUS Control Box	2-51
Row Marker Operation using ISOBUS	2-55
Row Marker Operation using Control Box	2-56
Row Marker Speed Adjustment	2-57
Row Marker Cable Adjustment	2-58
Row Marker Length And Disc Blade Adjustment	2-59
Vacuum Meter System	2-60
Analog Vacuum or Pressure Gauge	2-60
Bulk Fill System	2-61
Bulk fill Entrainer Access	2-62
Bulk Fill Tanks - Clean Out	2-63
Bulk Fill Scale Package Option	2-63
Monitor Seed Levels	2-64
Ag Leader InCommand 1200 Display	2-64
Master Module	2-64
Point Row Clutches	2-65
Field Test	2-66
Field Check Seed Population	2-66
Determining Pounds Per Acre	2-67
Determining Bushels Per Acre	2-67
Field Check Granular Chemical Application	2-68
Water Tank	2-69

ROW UNIT OPERATION

Planting Depth	3-1
“V” Closing Wheel Adjustment (Rubber or Cast Iron)	3-1
Closing Wheel Shield (Rubber or Cast Iron “V” Closing Wheels)	3-1
Covering Discs/Single Press Wheel Adjustment	3-2
Seed Hoppers	3-3
Quick Adjustable Down Force Springs Option	3-4
Pneumatic Down Pressure	3-5
Temperature Sensor Option	3-5
Field Operation	3-6
Manual Run Button	3-6
Vacuum Settings	3-7
Brush-Type Seed Meter	3-8
Finger Pickup Seed Meter	3-9
Seed Meter Cleanout	3-12
Additives	3-13
Bayer Fluency Agent	3-14
Row Unit Mounted No Till Coulter	3-14
GFX Hydraulic Row Cleaners	3-15
Start Up	3-15
Shut Down	3-15
Coulter or Row Unit Mounted Residue Wheels	3-16
Granular Chemical Banding Options	3-16
Granular Chemical Hopper and Drive	3-17

FERTILIZER

System overview	4-1
Centrifugal Pump	4-1
Piston Pump	4-4
Notched Single Disc Openers	4-5
Gauge Wheel Depth Adjustment	4-6
downforce settings	4-7
Knife Adjustment	4-8
Liquid Fertilizer Attachment	4-10
Check Valves	4-11
Rear Trailer Hitch Option	4-11

RATE CHARTS 5-1**LUBRICATION AND MAINTENANCE**

Lubrication	6-1
Lubrication Symbols	6-1
Wheel Bearings	6-1
Grease Fittings	6-2
Notched Single Disc Opener	6-8
PTO Shaft Coupling	6-9

Liquid Fertilizer Piston Pump Crankcase Oil Level 6-9

Liquid Fertilizer Centrifugal Pump 6-9

Mounting Bolts and Hardware 6-10

Tire Pressure 6-12

Transport Tires 6-12

Inflation Specifications 6-13

Finger Pickup Seed Meter Inspection/Adjustment 6-14

Cleaning Finger Pickup Seed Meter For Storage 6-15

Brush-Type Seed Meter Maintenance 6-16

Cleaning Brush-Type Seed Meter For Storage 6-17

Vacuum Manifold Maintenance 6-17

Vacuum Seed Meter Maintenance 6-18

Seed Meter Cleanout 6-18

Fertilizer Flow Sensor Cleanout 6-19

Vacuum Manifold Maintenance 6-21

Gauge Wheel Adjustment 6-21

Gauge Wheel Arm Pivot Spindle Replacement 6-21

Gauge Wheel Arm Bushing/Seal Replacement 6-22

15" Seed Opener Disc Blade/Bearing Assembly 6-23

Seed Tube Guard/Inner Scraper 6-24

Row Unit Mounted No Till Coulter 6-25

Coulter or Row Unit Mounted Residue Wheels 6-25

GFX Hydraulic Row Cleaners 6-26

Tractor Mounted Pump Drive and Oil Cooler 6-27

Check Valve 6-28

Flow Control Valves 6-28

Pressure Relief Valves 6-28

Pressure Compensated Flow Control Valves 6-28

Solenoid Valve 6-29

Pneumatic Down Pressure Air Compressor Tank 6-29

Row Marker Bearing Lubrication or Replacement 6-30

Transport and Lift/Ground Drive Wheel Bearing
Repack or Replacement 6-31

Fertilizer Check Valve Cleaning and Repair 6-32

Piston Pump Storage 6-32

Centrifugal Pump Storage 6-32

Preparation for Storage 6-33

Control Box Electrical Schematic 6-34

Wiring Harness Schematic Advanced ISOBUS 6-36

Electrical Wiring Diagram - Advanced ISOBUS 6-38

Electrical Wiring Diagram - KPM III 6-39

Electrical Wiring Diagram - ISOBUS 6-40

Base Machine Options Wiring Diagram 6-42

Row Unit Harness Diagram 6-43

Electrical Control Console Schematic -
Advanced ISOBUS 6-44

Electrical Control Console Connections - isobus 6-45

Advanced ISOBUS Extension Cable 6-47

Drawbar Hitch Cable 6-47

Lights Cable 6-48

Advanced ISO Planter Cable 6-48

ISOBUS Implement Cable 6-49

ISOBUS CAN Jumper Cable 6-49

Hydraulic Hose Life 6-62

Hydraulic Schematic (Planter Raising) 6-64

Hydraulic Schematic (Options) 6-66

(For Hydraulic Drive Option, see 6-66

“Hydraulic Schematic (Hydraulic Drive Option)” on page
6-68). 6-66

Hydraulic Schematic (Hydraulic Drive Option) 6-68

Hydraulic Valve Block Functions 6-69

TROUBLESHOOTING

Bulk Fill 7-1

Closing Wheel 7-1

Piston Pump 7-2

Centrifugal Pump 7-2

GFX Hydraulic Row Cleaners 7-3

Row Marker Operation 7-3

Vacuum Seed Meter 7-4

Solenoid Valve 7-6





PTO Pump Drive and Oil Cooler Option 7-6

Kinze Manufacturing, Inc. thanks you for your patronage. We appreciate your confidence in Kinze farm machinery. Your Kinze planter has been carefully designed to provide dependable operation in return for your investment.

This manual has been prepared to aid you in the operation and maintenance of the planter. It should be considered a permanent part of the machine and remain with the machine when you sell it.

It is the responsibility of the user to read and understand the Operator Manual in regards to safety, operation, lubrication and maintenance before operation of this equipment. It is the user's responsibility to inspect and service the machine routinely as directed in the Operator Manual. We have attempted to cover all areas of safety, operation, lubrication and maintenance; however, there may be times when special care must be taken to fit your conditions.

Throughout this manual the symbol  and the words **DANGER**, **WARNING**, and **CAUTION** are used to call attention to safety information that if not followed, will or could result in death or injury. **NOTICE** and **NOTE** are used to call your attention to important information. The definition of each of these terms follows:

	Indicates an imminently hazardous situation that, if not avoided, will result in death or serious injury. This signal word is to be limited to the most extreme situations, typically for machine components which, for functional purposes, cannot be guarded.
	Indicates a potentially hazardous situation that, if not avoided, could result in death or serious injury, and includes hazards that are exposed when guards are removed. It may also be used to alert against unsafe practices.
	Indicates a potentially hazardous situation that, if not avoided, may result in minor or moderate injury. It may also be used to alert against unsafe practices.
	Used to address safety practices not related to personal injury.

NOTE: Special point of information or machine adjustment instructions.

**WARNING**

Improperly operating or working on this equipment could result in death or serious injury. Read and follow all instructions in Operator Manual before operating or working on this equipment.

**WARNING**

Some photos in this manual may show safety covers, shields, or lockup devices removed for visual clarity. **NEVER OPERATOR OR WORK ON** machine without all safety covers, shields, and lockup device in place as required.

NOTE: Some photos in this manual may have been taken of prototype machines. Production machines may vary in appearance.

NOTE: Some photos and illustrations in this manual show optional attachments installed. Contact your Kinze Dealer for purchase of optional attachments.

WARRANTY

The Kinze Limited Warranty for your new machine is stated on the retail purchaser's copy of the Warranty And Delivery Receipt form. Additional copies of the Limited Warranty can be obtained through your Kinze Dealer.

Warranty, within the warranty period, is provided as part of Kinze's support program for registered Kinze products which have been operated and maintained as described in this manual. Evidence of equipment abuse or modification beyond original factory specifications will void the warranty. Normal maintenance, service and repair is not covered by Kinze warranty.

To register your Kinze product for warranty, a Warranty And Delivery Receipt form must be completed by the Kinze Dealer and signed by the retail purchaser, with copies to the Dealer, and to the retail purchaser. Registration must be completed and submitted to Kinze Manufacturing, Inc. within 5 business days of delivery of the Kinze product to the retail purchaser. Kinze Manufacturing, Inc. reserves the right to refuse warranty on serial numbered products which have not been properly registered.

If service or replacement of failed parts which are covered by the Limited Warranty are required, it is the user's responsibility to deliver the machine along with the retail purchaser's copy of the Warranty And Delivery Receipt to the Kinze Dealer for service. Kinze warranty does not include cost of travel time, mileage or hauling. Any prior arrangement made between the Dealer and the retail purchaser in which the Dealer agrees to absorb all or part of this expense should be considered a courtesy to the retail purchaser.

Kinze warranty does not include cost of travel time, mileage, hauling, or labor.

GENERAL INFORMATION

The Model 4900 Front Folding Planter is available in multiple sizes and row configurations with vacuum meter or mechanical meters, conventional hoppers or bulk fill, liquid fertilizer, and various other options. Contact your Kinze Dealer for additional details.



Model 4900 24 Row Bulk Fill Planter

Information used in these instructions was current at time of printing. However, due to Kinze's ongoing product improvement, production changes may cause your machine to appear slightly different in detail. Kinze Manufacturing, Inc. reserves the right to change specifications or design without notice and without incurring obligation to install the same on machines previously manufactured. To obtain the most recent version of your publication, please contact your Kinze dealer.

Right hand (R.H.) and left hand (L.H.), as used throughout this manual, are determined by facing direction machine travels in use unless otherwise stated.

TOOLS REQUIRED

Hardware Size / Tool Required			
$\frac{1}{4}'' = \frac{7}{16}''$	$\frac{7}{16}'' = \frac{5}{8}''$ (nut for $\frac{7}{16}''$ hardware uses $\frac{1}{16}''$ tool)	$\frac{3}{4}'' = 1\frac{1}{8}''$	$1\frac{1}{4}'' = 1\frac{7}{8}''$
$\frac{5}{16}'' = \frac{1}{2}''$	$\frac{1}{2}'' = \frac{3}{4}''$	$\frac{7}{8}'' = 1\frac{5}{16}''$	$1\frac{1}{2}'' = 2\frac{1}{4}''$
$\frac{3}{8}'' = \frac{9}{16}''$	$\frac{5}{8}'' = 1\frac{5}{16}''$	$1'' = 1\frac{1}{2}''$	

Specifications - Electric Drive

Specification	Conventional Hoppers			Bulk Fill		
Number of Rows	12	16	24	12	16	24
Row Spacing	30"	30"	30"	30"	30"	30"
Weight Empty (Vacuum Meter)	14,300 - 16,370 lb (6486 - 7425 kg)	18,930 - 20,180 lb (8586 - 9153 kg)	28,000 - 30,875 lb (12700 - 14005 kg)	14,300 - 16,370 lb (6486 - 7425 kg)	18,930 - 20,180 lb (8586 - 9153 kg)	28,000 - 30,875 lb (12700 - 14005 kg)
	*add 165 lb (75 kg) for optional flip axle (24R only)					
Weight Empty (Mechanical Meter)	17,070 - 18,000 lb (7743 - 8165 kg)	21,490 - 22,930 lb (9478 - 10401 kg)	31,525 - 33,720 lb (14300 - 15295 kg)	17,070 - 18,000 lb (7743 - 8165 kg)	21,490 - 22,930 lb (9478 - 10401 kg)	31,525 - 33,720 lb (14300 - 15295 kg)
	*add 165 lb (75 kg) for optional flip axle (24R only)					
Transport Height*	11'-0" (3.3M)	11'-1" (3.31M)	11'-4" (3.4M)	11'-7" (3.56M)	11'-9" (3.62M)	12'-0" (3.65M)
	*12R and 16R includes row markers and fertilizer *24R includes row markers, flip axle and fertilizer					
Planting Height	8'-8" (2.68M)	8'-8" (2.68M)	8'-8" (2.68M)	8'-9" (2.7M)	8'-11" (2.74M)	9'-3" (2.84M)
Planting Length*	17'-6" (5.36M)	20'-0" (6.09M)	27'-1" (8.26M)	19'-4" (5.91M)	21'-11" (6.43M)	28'-10" (8.56M)
	*add 2'-9" (0.8M) to total length for drawbar hitch *add 1'-2" (0.36M) to total length for 2 pt hitch					
Transport Length*	27'-7" (8.44M)	31'-9" (9.72M)	42'-2" (12.8M)	29'-5" (8.99M)	33'-5" (10.21M)	43'-8" (13.3M)
	*add 2'-9" to total length for drawbar hitch *add 1'-2" to total length for 2 pt hitch					
Planting Width	33'-4" (10.1M)	43'-4" (13.22M)	62'-5" (19M)	33'-4" (10.1M)	43'-4" (13.22M)	62'-5" (19M)
Transport Width (14'-0" with granular chemical option)	12'-0" (3.6M)	12'-0" (3.6M)	12'-0" (3.6M)	12'-0" (3.6M)	12'-0" (3.6M)	12'-0" (3.6M)
Seed Capacity	1.90 bu. / 3.0 bu.			90 bu.	120 bu.	120 bu.
Bulk Fill Dimensions (planting position height)	9' 4"					

Specifications - Ground or Hydraulic Drive

Specification	Conventional Hoppers			Bulk Fill		
	12	16	24	12	16	24
Number of Rows	12	16	24	12	16	24
Row Spacing	30"	30"	30"	30"	30"	30"
Weight Empty (Vacuum Meter)	14,300 - 16,370 lb (6486 - 7425 kg)	18,930 - 20,180 lb (8586 - 9153 kg)	28,000 - 30,875 lb (12700 - 14005 kg)	14,300 - 16,370 lb (6486 - 7425 kg)	18,930 - 20,180 lb (8586 - 9153 kg)	28,000 - 30,875 lb (12700 - 14005 kg)
	*add 165 lb (75 kg) for optional flip axle (24R only)					
Weight Empty (Mechanical Meter)	17,070 - 18,000 lb (7743 - 8165 kg)	21,490 - 22,930 lb (9478 - 10401 kg)	31,525 - 33,720 lb (14300 - 15295 kg)	17,070 - 18,000 lb (7743 - 8165 kg)	21,490 - 22,930 lb (9478 - 10401 kg)	31,525 - 33,720 lb (14300 - 15295 kg)
	*add 165 lb (75 kg) for optional flip axle (24R only)					
Transport Height*	11'-0" (3.3M)	11'-1" (3.31M)	11'-4" (3.4M)	11'-7" (3.56M)	11'-9" (3.62M)	12'-0" (3.65M)
	*12R and 16R includes row markers and fertilizer *24R includes row markers, flip axle and fertilizer					
Planting Height	8'-8" (2.68M)	8'-8" (2.68M)	8'-8" (2.68M)	8'-9" (2.7M)	8'-11" (2.74M)	9'-3" (2.84M)
Planting Length*	17'-6" (5.36M)	20'-0" (6.09M)	27'-1" (8.26M)	19'-4" (5.91M)	21'-11" (6.43M)	28'-10" (8.56M)
	*add 2'-9" (0.8M) to total length for drawbar hitch *add 1'-2" (0.36M) to total length for 2 pt hitch					
Transport Length*	27'-7" (8.44M)	31'-9" (9.72M)	42'-2" (12.8M)	29'-5" (8.99M)	33'-5" (10.21M)	43'-8" (13.3M)
	*add 2'-9" to total length for drawbar hitch *add 1'-2" to total length for 2 pt hitch					
Planting Width	33'-4" (10.1M)	43'-4" (13.22M)	62'-5" (19M)	33'-4" (10.1M)	43'-4" (13.22M)	62'-5" (19M)
Field Lift	12 Row - Four Master/Two Slave Hydraulics 16/24 Row - Four Master/Four Slave Hydraulics					
Row Markers	Independently controlled, three stage fold, disk blade depth bands.					

Tire Specifications

Specification	Conventional Hoppers			Bulk Fill		
Transport Tire Size (4) for 2014 production models	255-70R 22.5	41" x 11" R 22.5	41" x 11" R 22.5	255-70R 22.5	41" x 11" R 22.5	41" x 11" R 22.5
Transport Tire Pressure	100 psi (689 kPa)	75 psi (517 kPa)	75 psi (517 kPa)	100 psi (689 kPa)	75 psi (517 kPa)	75 psi (517 kPa)
Transport Tire Size (4) for 2015 production models and on	255-70R 22.5	11- 22.5 14 PR	11- 22.5 14 PR	255-70R 22.5	11- 22.5 14 PR	11- 22.5 14 PR
Transport Tire Pressure	100 psi (689 kPa)	90 psi (620 kPa)	90 psi (620 kPa)	100 psi (689 kPa)	90 psi (620 kPa)	90 psi (620 kPa)
Wing Tires for 2014 production models	7.5" x 20" (2)	7.5" x 20" (4)	41" x 11" R 22.5 (4)	7.5" x 20" (2)	7.5" x 20" (4)	41" x 11" R 22.5 (4)
Field Tire Pressure	40 psi (276 kPa)	40 psi (276 kPa)	60 psi (414 kPa)	40 psi (276 kPa)	40 psi (276 kPa)	60 psi (414 kPa)
Wing Tires for 2015 production models and on	7.5" x 20" (2)	7.5" x 20" (4)	11- 22.5 (4)	7.5" x 20" (2)	7.5" x 20" (4)	11- 22.5 (4)
Field Tire Pressure	40 psi (276 kPa)	40 psi (276 kPa)	90 psi (620 kPa)	40 psi (276 kPa)	40 psi (276 kPa)	60 psi (414 kPa)
Piston Pump Drive Tires (Optional)	(2) 7.60" x 15"					
Field Lift	12 Row - Four Master/Two Slave Hydraulics 16/24 Row - Four Master/Four Slave Hydraulics					
Row Markers	Independently controlled, three stage fold, disk blade depth bands.					

Tractor Hydraulic Requirements and Use of Power Beyond

The Power Beyond hydraulic system is used as a pressure/flow source for additional functions equipped with independent flow control valves; for example, bulk fill fan. Possible scenarios include:

- Tractor Selective Control Valve (SCV) control is not needed.
- No other SCV outlet is available.

The major difference between SCV and Power Beyond is that an SCV has built-in pressure/flow compensation whereas Power Beyond requires an external load signal.

Kinze suggests that if Power Beyond must be used, only the bulk fill circuit be connected using all three connections (Pressure, Return, Load Sense). Consult your tractor manufacturer to ensure proper connection, hydraulic flow, pressure and heat dissipation are met.

For more information on Power Beyond for remote hydraulic connections, refer to the tractor Operator's Manual.

Selective Control Valve (SCV) Identification

- #1 SCV: Planter Lift (Red Labels)
- #2 SCV: Markers/Fold (Blue Labels)
- #3 SCV: Weight Distribution/Bulk Fill/Fertilizer (Yellow Labels)
- #4 SCV: Power Pack/Hydraulic Drive (Black Labels)
- #5 & #6 SCV: Vacuum (PTO) (Green Labels)

Hydraulic Requirements @ 2350 psi	12 Row with PTO pump*		12 Row without PTO pump		16 Row with PTO pump*		16 Row without PTO pump		24 Row with PTO pump*		24 Row without PTO pump	
	Configuration	GPM**	SCV	GPM**	SCV***	GPM**	SCV	GPM**	SCV***	GPM**	SCV	GPM**
Electric or Hydraulic Drive/Bulk Fill/Vacuum Meters	42	4	57	6	43	4	59	6	44	4	61	6
Electric or Hydraulic Drive/Hoppers/Vacuum Meters	36	4	51	6	36	4	52	6	36	4	53	6
Ground Contact Drive/Bulk Fill/Vacuum Meters	34	3	49	5	35	3	51	5	36	3	53	5
Ground Contact Drive/Hoppers/Vacuum Meters	28	3	43	5	28	3	44	5	28	3	45	5
Ground Contact Drive/Bulk Fill/Mechanical Meters	N/A	N/A	34	3	N/A	N/A	35	3	N/A	N/A	36	3
Ground Contract Drive/Hoppers/Mechanical Meters	N/A	N/A	28	3	N/A	N/A	30	3	N/A	N/A	32	3
Hydraulic Drive/Hoppers/Mechanical Meters	N/A	N/A	38	4	N/A	N/A	40	4	N/A	N/A	42	4
Hydraulic Drive/Bulk Fill/Mechanical Meters	N/A	N/A	44	4	N/A	N/A	45	4	N/A	N/A	46	4

*PTO hydraulic pump supplies oil flow for vacuum hydraulic circuit

**Add 4 GPM when using centrifugal fertilizer pump option

***Power Beyond use will reduce the number of SCVs by 1. Not recommended - Kinze suggests that if Power Beyond must be used, only the bulk fill circuit be connected using all three connections (Pressure, Return, Load Sense). Consult your tractor manufacturer for recommendations.



ADDITIONAL NOTES:



- All 4900 planters require an external case drain hose.
- All SCVs should be set to max flow at all times with the exception of the bulk fill circuit on mechanical 4900.
- Tractor RPMs not recommended below 1750 RPMs.
- Consult your tractor manufacturer to ensure proper connection, hydraulic flow, pressure and heat dissipation.

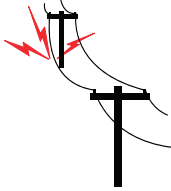

1. Read and understand instructions provided in this manual and warning labels. Review these instructions frequently!
 2. This machine is designed and built with your safety in mind. Do not make any alterations or changes to this machine. Any alteration to design or construction may create safety hazards.
 3. A large portion of farm accidents happen from fatigue or carelessness. Safe and careful operation of tractor and planter will help prevent accidents.
 4. Never allow planter to be operated by anyone unfamiliar with operation of all functions of the unit. Operators must read and thoroughly understand all instructions given in this manual before operating or working on equipment.
 5. Be aware of bystanders, particularly children! Always look around to make sure it is safe to start tow vehicle engine or move planter. This is particularly important with higher noise levels and quiet cabs, as you may not hear people shouting.
 6. Make sure planter weight does not exceed towing capacity of tractor, or bridge and road limits. This is critical to maintain safe control and prevent death or injury, or property and equipment damage.
 7. Never ride or allow others to ride on planter.
 8. Store planter in an area away from human activity. DO NOT permit children to play on or around the stored unit.
 9. Keep hands, feet, and clothing away from moving parts. Do not wear loose-fitting clothing which may catch in moving parts.
 10. Always wear protective clothing, shoes, gloves, hearing, and eye protection applicable for the situation.
 11. Do not allow anyone to stand between tongue or hitch and towing vehicle when backing up to planter.
 13. Prevent electrocution, other injuries, or property and equipment damage. Watch for obstructions such as wires, tree limbs, etc. when operating machine. Be aware of clearances during turns and when folding/unfolding planter.
 14. Reinstall all guards removed for maintenance activities. Never leave guards off during operation.
 15. Use of aftermarket hydraulic, electric, or PTO drives may create serious safety hazards to you and people nearby. If you install such drives, follow all appropriate safety standards and practices to protect you and others near this planter from injury.
 16. Follow all federal, state/provincial, and local regulations when towing farm equipment on a public highway. Use safety chain (not an elastic or nylon/plastic tow strap) to retain connection between towing and towed machines in the event of primary attaching system separation.
 17. Make sure all safety/warning lights, SMV sign, and reflective decals are in place and working properly before transporting the machine on public roads.
 18. Limit towing speed to 24 km/h. Tow only with farm tractor of a minimum 90 HP. Allow for unit length when making turns.
 19. Reduce speed prior to turns to avoid the risk of overturning. Always drive at a safe speed relative to local conditions and ensure your speed is slow enough for a safe emergency stop.
 20. Chemical application is often an integral part of planting. Follow label instructions for proper chemical mixing, handling and container disposal methods.
 21. Be familiar with safety procedures for immediate first aid should you accidentally contact chemical substances.
 22. Use the proper protective clothing and safety equipment when handling chemicals.
 23. Chemicals are supplied with Material Safety Data Sheets (MSDS) that provide full information about the chemical, its effects on exposure, and first aid needs in the event of an emergency. Keep your MSDS file up-to-date and available for first responders in case of emergency.
 24. When servicing ground engaging components such as opening disks and firming points, use special care to avoid points and edges worn sharp during use.
 25. Use professional help if you are unfamiliar with working on hydraulic systems. Pressurized hydraulic fluid can penetrate body tissue and result in death, serious infection, or other injuries.
 26. Disposing of waste improperly can threaten the environment. To dispose of your equipment properly contact your local environmental or recycling center.
- Never pour waste onto the ground, down a drain, or into any water source.
- When disposing of waste such as oil, use leakproof containers. Be sure to use containers that do not resemble food or beverage which may mislead someone into consuming them. Dispose of oil per your local, regional requirements.
- When disposing of any fertilizer chemicals used, contact the supplier of the chemicals.
- Model 4900 planter consists of 85% recyclable metals, 10% recyclable plastic and rubber, and 5% waste.

Following are some common hazard warnings associated with this equipment. Pay close attention to all safety, operating, and maintenance information in this manual and decals applied to your equipment.

 <p>DANGER</p>	<p>Contacting or coming close to power lines or other high energy sources will cause death or serious injury.</p>
	<p>Keep away from power lines or high energy sources at all times.</p>

 <p>WARNING</p>	<p>Improperly operating or working on this equipment could result in death or serious injury. Read and follow all instructions in Operator Manual before operating or working on this equipment.</p>
	

 <p>WARNING</p>	<p>Falling equipment can cause death or serious injury. Install all lockup devices or lower planter to ground before working on equipment.</p>
	

 <p>WARNING</p>	<p>Explosive separation of rim and tire parts can cause death or serious injury. Overinflation, rim and tire servicing, improper use of rims and tires, or worn or improperly maintained tires could result in a tire explosion.</p>
	

SAFETY SIGNS AND DECALS

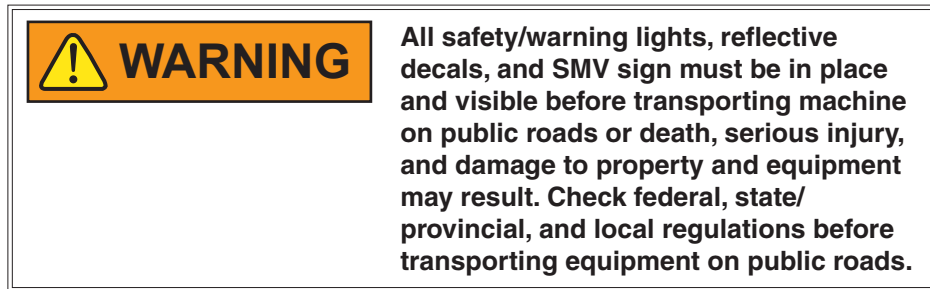

Safety signs and decals are placed on the machine to warn of hazards and provide important operating and maintenance instructions. Information on these signs are for your personal safety and the safety of those around you. FOLLOW ALL SAFETY INSTRUCTIONS!



- **Keep signs clean so they can be easily seen. Wash with soap and water or cleaning solution as required.**
- **Replace safety signs if damaged, painted over, or missing.**
- **Check reflective decals and SMV sign periodically. Replace if they show any loss of reflective properties.**
- **When replacing decals, clean machine surface thoroughly with soap and water or cleaning solution to remove all dirt and grease.**

NOTE: Safety sign and decal locations are shown in the Parts Manual for this machine.

NOTE: Style and locations of SMV sign, reflective decals, and safety/warning lights conform to ANSI/ASABE S279.14 JUL 2008 and ANSI/ASABE S276.6 JAN 2005.

This page intentionally left blank.

ROW MARKER SAFETY LOCKUP

 WARNING	Row marker can lower at any time and could cause death or serious injury. Stay away from row markers! Install safety lockup device when not in use.
	



Row Marker Safety Lockup Stored



Row Marker Safety Lockup Installed

Always install row marker lockups when working on, storing, or transporting planter. Hold in place with two clevis pins.

TRANSPORT AXLE CYLINDER SAFETY LOCKUP

 <p>WARNING</p>	<p>Transport axle can lower from transport position without the use of any controller, causing death, serious injury, or damage to property and equipment. Do not operate any hydraulic function while transporting the planter. Make sure all transport safety lockups are installed on the four transport cylinders and all SCV controls are in their neutral state before transporting, storing and working on the planter.</p>
---	--

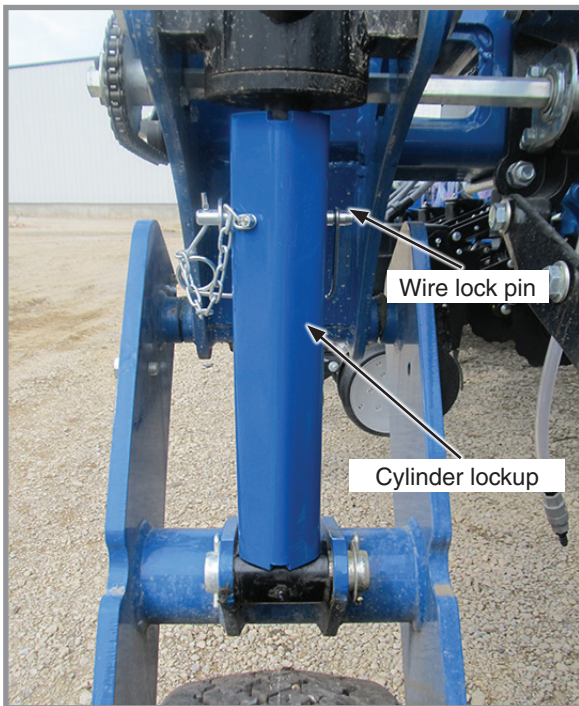

Transport axle cylinder lockup installed





Cylinder lockup storage tube

Transport axle cylinder lockups are required on all four transport cylinders on planter when working on, storing, or transporting planter.

Fully extend cylinder to raised position. Install transport axle cylinder lockups. Insert wire lock pin through holes on cylinder lockup and secure.

Store transport axle cylinder lockups in cylinder lockup storage tube before operating planter.

 WARNING	<p>Planter hitch may raise uncontrollably during folding/unfolding and can cause death, serious injury, or damage property and equipment. DO NOT fold or unfold planter without planter attached to a tractor. DO NOT unhitch planter from tractor unless fully folded for transport or fully unfolded with planting units lowered to ground.</p>
--	---

 WARNING	<p>Uncontrolled movement of equipment can cause loss of control and could result in death, serious injury, or damage to property and equipment. Install all safety pins before transporting equipment.</p>
	

DRAWBAR HITCH LOCKUP (OPTION)

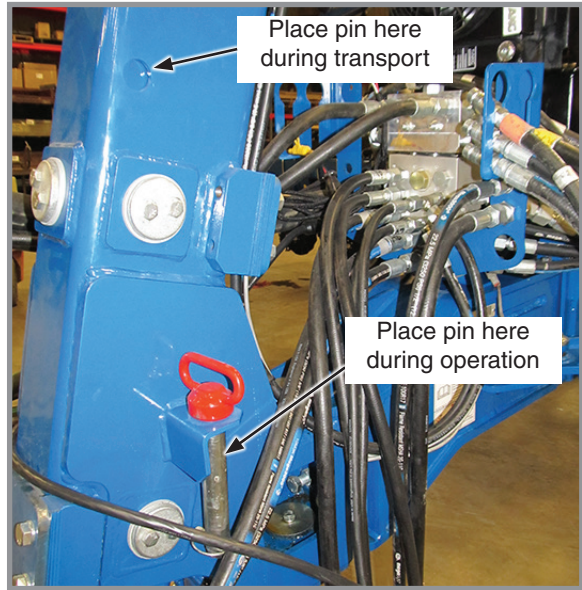

Place the drawbar hitch lockup pin in the hole shown above when machine is in operation.

2-POINT HITCH OPTION





Jacks in Maintenance Position

For transporting, store jacks on both sides of hitch. Secure in place with spring pin.

 WARNING	Improperly operating or working on this equipment could result in death or serious injury. Read and follow all instructions in Operator Manual before operating or working on this equipment.
	

INITIAL PLANTER PREPARATION

Following information is general in nature to aid in preparation of tractor and planter for use, and to provide general operating procedures. Operator experience, familiarity with the machine, and the following information should combine for efficient planter operation and good working habits.

 WARNING	Explosive separation of rim and tire parts can cause death or serious injury. Overinflation, rim and tire servicing, improper use of rims and tires, or worn or improperly maintained tires could result in a tire explosion.
	

 WARNING	Wheel separation can cause loss of control resulting in death, serious injury, or damage to property and equipment. Check lug nuts on transport wheels are tight before operating planter for first time and periodically after.
--	---

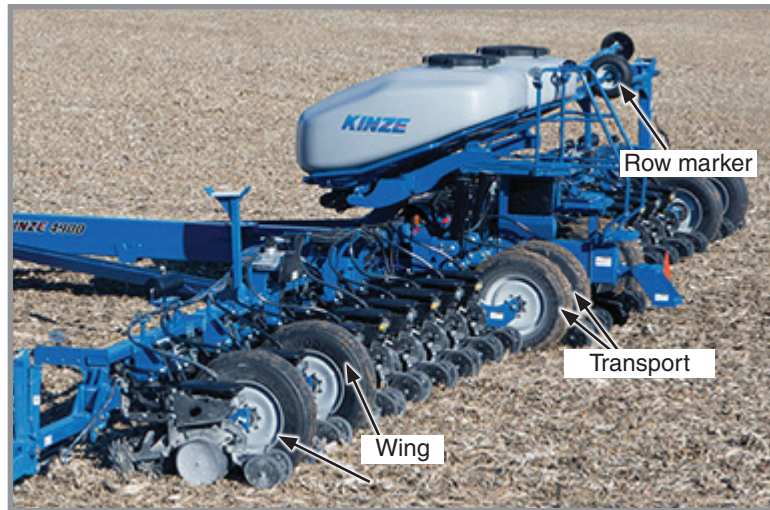

Tire locations (L.H. shown)

1. Torque transport wheel $\frac{3}{4}$ " - 16 lug nuts to 200 ft-lb (244 N-m).
2. Inflate tires to the following specifications:
 - **2014 Production:** Wing - 12R and 16R: 7.5" x 20" - 40 psi (275.7 kPa), 24R: 41" x 11" - 60 psi (413.6 kPa)
 - **2015 Production:** Wing - 12R and 16R: 7.5" x 20" - 40 psi (275.7 kPa), 24R: 11 - 22.5 - 90 psi (620.5 kPa)
 - **2014 Production:** Transport - 12R: 255-70R, 22.5 - 100 psi (689.4 kPa), 16R and 24R: 41" x 11" - 75 psi (517.1 kPa)
 - **2015 Production:** Transport - 12R: 255-70R, 22.5 - 100 psi (689.4 kPa), 16R and 24R: 11 - 22.5 - 90 psi (620.5kPa)
 - Contact drive - 4.80" x 8" - 50 psi (344.7 kPa)
 - Row marker - 16" x 6.5" x 8" - 14 psi (96.5 kPa)
3. Lubricate planter and row units per lubrication information in this manual.
4. Check all drive chains for proper tension, alignment, and lubrication.

TRACTOR REQUIREMENTS



WARNING

Loss of control of equipment during transport can result in death, serious injury, or damage to property and equipment. Tractor gross weight must be greater than planter gross weight with attachments and options.

NOTICE

Connect hydraulic motor case drain to a case drain return line with zero PSI on tractor. Failure to connect to a return with zero PSI will cause hydraulic motor shaft seal damage. **DO NOT** connect hydraulic motor case drain to a SCV outlet or motor return circuit connection. Contact tractor manufacturer for specific details on “zero pressure return”.

NOTICE

All Hydraulic Requirements: Minimum Pressure 2350 PSI (16202.6 kPa); Maximum Pressure 3000 PSI (20684.2 kPa). Check tractor hydraulics to ensure that maximum pressure cannot be exceeded.

Consult your dealer for information on horsepower requirements and tractor compatibility. Requirements vary with planter options, tillage, and terrain.

Three dual remote hydraulic outlets (SCV) are required on all sizes of conventional planters equipped with row markers.

Four dual remote hydraulic outlets (SCV) are required on all sizes of bulk fill planters equipped with row markers. A 12 volt DC electrical system is required on all sizes.

Six dual remote hydraulic outlets (SCV) are required on all sizes of planters equipped with vacuum meters but without PTO pump.

VACUUM METER TRACTOR MOUNTED PTO PUMP AND PLANTER MOUNTED HYDRAULICS

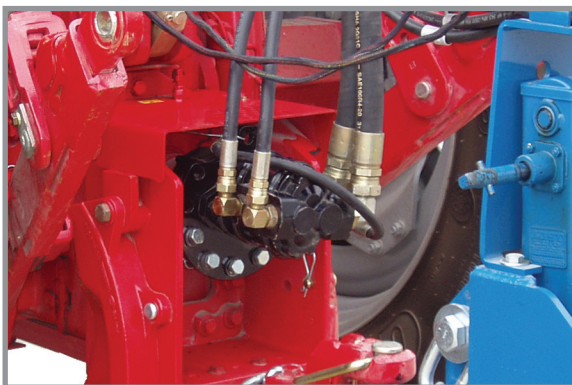

Two-section PTO Hydraulic Pump



8 gal (30.3 L) Reservoir

Vacuum meter equipped planters require a 1 $\frac{1}{4}$ "-20 spline 1000 RPM PTO to operate PTO-driven two section hydraulic pump capable of supplying 15 gpm (56.8 Lpm) to two hydraulic motors/vacuum fans.

NOTE: A tractor model-specific mount kit is required for the PTO-mounted pump.

Contact GnL Engineering (319-227-7222) or Rowe Manufacturing (800-544-4123) for your tractor pump mount requirements.

Vacuum Seed Metering System operates from an 8 gal (30.3 L) capacity oil reservoir.

NOTE: Check that open center plug is removed from fan block before operating.

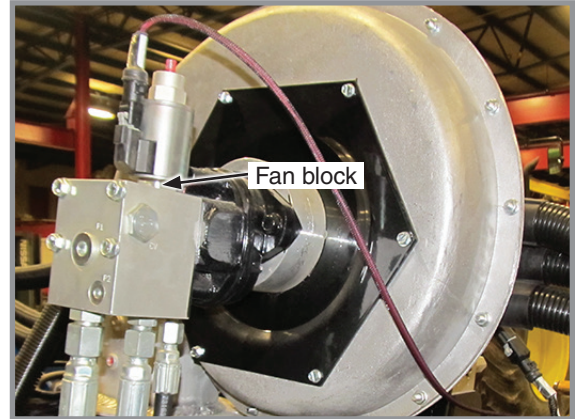

Vacuum Fan Block

Other dual fan system components include one oil cooler, one replaceable cartridge-type filter, and two pressure compensating flow-control valves.

TRACTOR PREPARATION AND HOOKUP

1. Back tractor to planter and connect with minimum 1 $\frac{1}{4}$ " diameter hitch pin or 2 point hitch. Make sure hitch pin is secured with a locking pin or cotter pin if tractor is not equipped with a hitch pin locking device or 2-point hitch.

NOTE: DO NOT install safety chain using clevis mounting hardware. Safety chain MUST be installed separately.

2. For planters with drawbar hitch, safety chain must be used to keep planter and tractor connected in case of a hitch pin/drawbar failure. Attach safety chain at an unused clevis mounting hole on the planter hitch. Torque hardware to 840 ft-lb (1138.8 N-m).

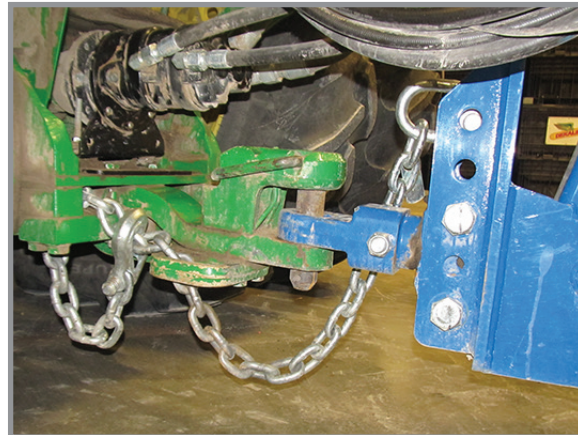

Tractor and Safety Chain Hookup for Drawbar Hitch

WARNING

Pressurized hydraulic fluid can penetrate body tissue and result in death, serious infection, or other injuries. Fluid injected under skin must be **IMMEDIATELY** removed by a surgeon familiar with this type of injury. Make sure connections are tight and hoses and fittings are not damaged before applying system pressure. Leaks can be invisible. Keep away from suspected leaks. Relieve pressure before searching for leaks or performing any system maintenance.



NOTICE

Wipe hose ends to remove any dirt before connecting couplers to tractor ports or contamination may cause equipment failure.

NOTICE

Always connect hydraulic motor return hose to tractor motor return port. Do not connect to tractor SCV unless through a motor spool or hydraulic motor failure can occur. If a motor return port is not available on the tractor, the SCV controlling the bulk fill system **MUST** be in the float position before planter is moved in planting or field raised position when bulk fill system is not in use.

3. Connect hydraulic hoses to tractor ports in a sequence familiar and comfortable to the operator. Refer to chart on the following page.

Color and Label	Machine Function	Hose Size	Hose Function
Red AA	Field Lift	1/2"	Pressure/Return
Red BB		1/2"	Pressure/Return
Blue AA	Planter Fold & Row Marker	3/8"	Pressure/Return
Blue BB		3/8"	Pressure/Return
Black RR	Power Pack	5/8"	Return
Black PP		1/2"	Pressure
Orange CD		3/8"	Case Drain
Yellow RR	Bulk Fill System Pressure Fan (Hydraulic Weight Transfer)	5/8"	Return
Yellow PP		1/2"	Pressure
Orange CD		3/8"	Case Drain
Green RR	Vacuum Meter Fans	5/8"	Return
Green PP		1/2"	Pressure
Orange CD		3/8"	Case Drain

NOTICE

Clean and grease PTO shaft coupling with high-pressure industrial coupling grease (Chevron® coupling grease or equivalent) meeting AGMA CG-1 and CG-2 Standards each time driveshaft is installed or premature wear and equipment failure can occur.

NOTE: A tractor model-specific PTO mount kit is required and available from GnL Engineering (319-227-7222 or gnlengineering.net) and Rowe Manufacturing (800-544-4123 or rowemfg.com).

4. (If applicable) Install PTO pump onto tractor PTO shaft. Make sure shaft rotation matches direction indicated on pump housing.
5. If equipped with ISOBUS system, attach ISO connector.
6. For planters not equipped with ISOBUS, connect ASABE Standards 7 terminal connector for safety/warning lights on planter to ASABE Standards receptacle on tractor. If your tractor is not equipped with an ASABE Standards receptacle, check with your tractor manufacturer for availability. Check warning lights on planter work in conjunction with warning lights on tractor.
7. Completely raise parking stands to prevent damage to stands and equipment when moving planter.
8. (If applicable) Connect compressor harness.

CYLINDER INFORMATION

	Row Marker Cylinder, 12 Row	Row Marker Cylinder, 16 and 24 Row	Drawbar Hitch Cylinder, 12 and 16 Row	Drawbar Hitch Cylinder, 24 Row	Fold Cylinder, 12 and 16 Row
Intended Use	Double acting applications	Double acting applications	Double acting applications	Double acting applications	Double acting applications
Piston	Ductile iron	Ductile iron	Ductile iron	Ductile iron	Ductile iron
Gland	Ductile iron	Ductile iron	Ductile iron	Ductile iron	Ductile iron
Tube	ST 52 Dom	ST 52 Dom	ST 52 Dom	ST 52 Dom	ST 52 Dom
Rod	1045 Nitro rod	1045 Nitro rod	1045 Nitro rod	1045 Nitro rod	1045 Nitro rod
End Mounts	Sleeve	Sleeve	Through End Cap	Through End Cap	Through End Cap
Tube Seal	Buna O-ring with polytemp back-up	Buna O-Ring with polytemp back-up	Buna O-Ring with polytemp back-up	Buna O-ring with polytemp back-up	Buna O-ring with polytemp back-up
Rod Seal	Polyester alloy u-cup	Polyester alloy u-cup	Polyester alloy u-cup	Polyester alloy u-cup	Polyester alloy u-cup
Rod Wiper	Polyester alloy snap in	Polyester alloy snap in	Polyester alloy snap in	Polyester alloy snap in	Polyester alloy snap in
Piston Seal	T-seal hnbr	PTFE	T-seal hnbr	T-seal hnbr	T-seal hnbr
Specifications					
Product Category	Hydraulic Cylinder	Hydraulic Cylinder	Hydraulic Cylinder	Hydraulic Cylinder	Hydraulic Cylinder
Maximum Stroke	18.75" (47.62 cm)	20.75" (52.70 cm)	56" (142.2 cm)	31.62" (80.31 cm)	25.75" (65.40 cm)
Working Pressure	3000 PSI (20684.27 kPa)	3000 PSI (20684.27 kPa)	3000 PSI (20684.27 kPa)	3000 PSI (20684.27 kPa)	3000 PSI (20684.27 kPa)
Bore Size	2.5" (6.35 cm)	3.5" (8.89 cm)	3" (7.62 cm)	4" (10.16 cm)	4.5" (11.43 cm)
Shaft Diameter	1.25" (31.75 mm)	1.5" (3.81 cm)	1.75" (4.44 cm)	2.5" (6.35 cm)	2" (5.08 cm)
Cylinder Configuration	Simple	Simple	Simple	Simple	Simple
Cylinder Action	Double	Double	Double	Double	Double
Material	Steel, Ductile iron	Steel, Ductile iron	Steel, Ductile iron	Steel, Ductile iron	Steel, Ductile iron
Mounting Method	Sleeve	Sleeve	End Cap	End Cap	End Cap
Mount Location	End Cap	End Cap	End Cap	End Cap	End Cap
Cylinder Style	Welded	Welded	Welded	Welded	Welded

CYLINDER INFORMATION

	Fold Cylinder, 12 and 16 Row	Fold Cylinder, 24 Row (2014 Production)	Fold Cylinder, 24 Row (2014 Production)	Fold Cylinder, 24 Row (2015 Production)	Fold Cylinder, 24 Row (2015 Production)
Intended Use	Double acting applications	Double acting applications	Double acting applications	Double acting applications	Double acting applications
Piston	Ductile iron	Ductile iron	Ductile iron	Ductile iron	Ductile iron
Gland	Ductile iron	Ductile iron	Ductile iron	Ductile iron	Ductile iron
Tube	ST 52 Dom	ST 52 Dom	ST 52 Dom	ST 52 Dom	ST 52 Dom
Rod	1045 Nitro rod	1045 Nitro rod	1045 Nitro rod	1045 Nitro rod	1045 Nitro rod
End Mounts	Through End Cap	Sleeve	Sleeve	Sleeve	Sleeve
Tube Seal	Buna O-ring with polytemp back-up	Buna O-ring with polytemp back-up	Buna O-ring with polytemp back-up	Buna O-ring with polytemp back-up	Buna O-ring with polytemp back-up
Rod Seal	Polyester alloy u-cup	Polyester alloy u-cup	Polyester alloy u-cup	Polyester alloy u-cup	Polyester alloy u-cup
Rod Wiper	Polyester alloy snap in	Polyester alloy snap in	Polyester alloy snap in	Polyester alloy snap in	Polyester alloy snap in
Piston Seal	T-seal HNBR	OK Seal 70A Nitrile	OK Seal 70A Nitrile	OK Seal 70A Nitrile	OK Seal 70A Nitrile
Specifications					
Product Category	Hydraulic Cylinder	Hydraulic Cylinder	Hydraulic Cylinder	Hydraulic Cylinder	Hydraulic Cylinder
Maximum Stroke	25.75" (65.40 cm)	39.375" (100 cm)	39.375" (100 cm)	39.375" (100 cm)	39.375" (100 cm)
Working Pressure	3000 PSI (20684.27 kPa)	3000 PSI (20684.27 kPa)	3000 PSI (20684.27 kPa)	3000 PSI (20684.27 kPa)	3000 PSI (20684.27 kPa)
Bore Size	4.5" (11.43 cm)	6" (15.24 cm)	6" (15.24 cm)	6" (15.24 cm)	6" (15.24 cm)
Shaft Diameter	2" (5.08 cm)	2.5" (6.35 cm)	2.5" (6.35 cm)	2.5" (6.35 cm)	2.5" (6.35 cm)
Cylinder Configuration	Simple	Simple	Simple	Simple	Simple
Cylinder Action	Double	Double	Double	Double	Double
Material	Steel, Ductile iron	Steel, Ductile iron	Steel, Ductile iron	Steel, Ductile iron	Steel, Ductile iron
Mounting Method	End Cap	Sleeve	Sleeve	Sleeve	Sleeve
Mount Location	End Cap	Sleeve	Sleeve	Sleeve	Sleeve
Cylinder Style	Welded	Welded	Welded	Welded	Welded

CYLINDER INFORMATION

	Wing Cylinder, 12 Row	Wing Cylinder, 16 Row	Wing Cylinder, 24 Row (Non-Flip Axle)	Wing Cylinder, 24 Row (Flip Axle)	Master Cylinder Center, 12 Row
Intended Use	Double acting applications	Double acting applications	Double acting applications	Double acting applications	Double acting applications
Piston	Ductile iron	Ductile iron	Ductile iron	Ductile iron	Ductile iron
Gland	Ductile iron	Ductile iron	Ductile iron	Ductile iron	Ductile iron
Tube	ST 52 Dom	ST 52 Dom	ST 52 Dom	ST 52 Dom	ST 52 Dom
Rod	1045 Nitro rod	1045 Nitro rod	1045 Nitro rod	1045 Nitro rod	1045 Nitro rod
End Mounts	Trunion	Trunion	Trunion	Trunion	Trunion
Tube Seal	Buna O-ring with polytemp back-up	Buna O-ring with polytemp back-up	Buna O-ring with polytemp back-up	Buna O-ring with polytemp back-up	Buna O-ring with polytemp back-up
Rod Seal	Polyester alloy u-cup	Polyester alloy u-cup	Polyester alloy u-cup	Polyester alloy u-cup	Polyester alloy u-cup
Rod Wiper	Polyester alloy snap in	Polyester alloy snap in	Polyester alloy snap in	Polyester alloy snap in	Polyester alloy snap in
Piston Seal	PTFE Seal	PTFE Seal	PTFE Seal	PTFE Seal	PTFE Seal
Specifications					
Product Category	Hydraulic Cylinder	Hydraulic Cylinder	Hydraulic Cylinder	Hydraulic Cylinder	Hydraulic Cylinder
Maximum Stroke	9.875" (25.08 cm)	10" (25.4 cm)	9.25" (23.49 cm)	9.25" (23.49 cm)	13.5" (34.29 cm)
Working Pressure	3000 PSI (20684.27 kPa)	3000 PSI (20684.27 kPa)	3000 PSI (20684.27 kPa)	3000 PSI (20684.27 kPa)	3000 PSI (20684.27 kPa)
Bore Size	3.75" (9.52 cm)	3.5" (8.89 cm)	3.75" (9.52 cm)	4.25" (10.79 cm)	3" (7.62 cm)
Shaft Diameter	1.375" (3.49 cm)	1.25" (3.17 cm)	1.375" (3.49 cm)	1.75" (4.44 cm)	1.125" (2.85 cm)
Cylinder Configuration	Simple	Simple	Simple	Simple	Simple
Cylinder Action	Double	Double	Double	Double	Double
Material	Steel, Ductile iron	Steel, Ductile iron	Steel, Ductile iron	Steel, Ductile iron	Steel, Ductile iron
Mounting Method	Trunion	Trunion	Trunion	Trunion	Trunion
Mount Location	Trunion	Trunion	Trunion	Trunion	Trunion
Cylinder Style	Welded	Welded	Welded	Welded	Welded

CYLINDER INFORMATION

	Master Cylinder Center, 16 Row	Master Cylinder Center, 24 Row (Non-Flip Axle)	Wing Cylinder Center, 24 Row (Flip Axle)	Wing Down Pressure Cylinder, 12 and 16 Row	Wind Down Pressure Cylinder, 24 Row
Intended Use	Double acting applications	Double acting applications	Double acting applications	Double acting applications	Double acting applications
Piston	Ductile iron	Ductile iron	Ductile iron	Ductile iron	Ductile iron
Gland	Ductile iron	Ductile iron	Ductile iron	Ductile iron	Ductile iron
Tube	ST 52 Dom	ST 52 Dom	ST 52 Dom	ST 52 Dom	ST 52 Dom
Rod	1045 Nitro rod	1045 Nitro rod	1045 Nitro rod	1045 Nitro rod	1045 Nitro rod
End Mounts	Trunion	Sleeve	Trunion	Sleeve	Sleeve
Tube Seal	Buna O-ring with polytemp back-up	Buna O-ring with polytemp back-up	Buna O-ring with polytemp back-up	Buna O-ring with polytemp back-up	Buna O-ring with polytemp back-up
Rod Seal	Polyester alloy u-cup	Polyester alloy u-cup	Polyester alloy u-cup	Polyester alloy u-cup	Polyester alloy u-cup
Rod Wiper	Polyester alloy snap in	Polyester alloy snap in	Polyester alloy snap in	Polyester alloy snap in	Polyester alloy snap in
Piston Seal	PTFE Seal	PTFE Seal	PTFE Seal	T-seal HNBR	T-seal HNBR
Specifications					
Product Category	Hydraulic Cylinder	Hydraulic Cylinder	Hydraulic Cylinder	Hydraulic Cylinder	Hydraulic Cylinder
Maximum Stroke	12" (30.48 cm)	11.125" (28.25 cm)	32.874" (83.49 cm)	12.13" (30.81 cm)	20" (50.8 cm)
Working Pressure	3000 PSI (20684.27 kPa)	3000 PSI (20684.27 kPa)	3000 PSI (20684.27 kPa)	3000 PSI (20684.27 kPa)	3000 PSI (20684.27 kPa)
Bore Size	4" (10.16 cm)	4.5" (11.43 cm)	4.75" (12.06 cm)	2" (5.08 cm)	2" (5.08 cm)
Shaft Diameter	1.5" (3.81 cm)	1.75" (4.44 cm)	2" (5.08 cm)	1.25" (3.17 cm)	1.25" (3.17 cm)
Cylinder Configuration	Simple	Simple	Simple	Simple	Simple
Cylinder Action	Double	Double	Double	Double	Double
Material	Steel, Ductile iron	Steel, Ductile iron	Steel, Ductile iron	Steel, Ductile iron	Steel, Ductile iron
Mounting Method	Trunion	Sleeve	Trunion	Sleeve	Sleeve
Mount Location	Trunion	End Cap	Trunion	End Cap	End Cap
Cylinder Style	Welded	Welded	Welded	Welded	Welded

HYDRAULIC HOSE INFORMATION

Part Number	A1010	A1026	A1027	A1029	A1030	A1041
Description	Hose Assembly 3/8" X 120" (08F - 08F)	Hose Assembly 3/8" X 152" (08F - 08F)	Hose Assembly 3/8" X 182" (08F - 08F)	Hose Assembly 3/8" X 190" (08F - 08F)	Hose Assembly 3/8" X 192" (08F - 08F)	Hose Assembly 3/8" X 130" (8F - 8F)
Product Category	Hydraulic Hose	Hydraulic Hose	Hydraulic Hose	Hydraulic Hose	Hydraulic Hose	Hydraulic Hose
Product Form	Hose; Assembly	Hose; Assembly	Hose; Assembly	Hose; Assembly	Hose; Assembly	Hose; Assembly
I.D.	3/8" (9.525 mm)	3/8" (9.525 mm)	3/8" (9.525 mm)	3/8" (9.525 mm)	3/8" (9.525 mm)	3/8" (9.525 mm)
O.D.	.63" (16.002 mm)	.63" (16.002 mm)	.63" (16.002 mm)	.63" (16.002 mm)	.63" (16.002 mm)	.63" (16.002 mm)
Minimum Bend Radius	2" (5.08 cm)	2" (5.08 cm)	2" (5.08 cm)	2" (5.08 cm)	2" (5.08 cm)	2" (5.08 cm)
Working Pressure	3250 PSI (22407.96 kPa)	3250 PSI (22407.96 kPa)	3250 psi (22407.96 kPa)	3250 psi (22407.96 kPa)	3250 PSI (22407.96 kPa)	3250 PSI (22407.96 kPa)
Temperature Range	-40°F - +212°F (-40°C - +100°C)	-40°F - +212°F (-40°C - +100°C)	-40°F - +212°F (-40°C - +100°C)	-40°F - +212°F (-40°C - +100°C)	-40°F - +212°F (-40°C - +100°C)	-40°F - +212°F (-40°C - +100°C)
Material	Modified Nitrile Type C2	Modified Nitrile Type C2	Modified Nitrile Type C2	Modified Nitrile Type C2	Modified Nitrile Type C2	Modified Nitrile Type C2
Specialized Construction	High Tensile Steel Wire	High Tensile Steel Wire	High Tensile Steel Wire	High Tensile Steel Wire	High Tensile Steel Wire	High Tensile Steel Wire
Media	Hydraulic Fluid	Hydraulic Fluid	Hydraulic Fluid	Hydraulic Fluid	Hydraulic Fluid	Hydraulic Fluid
Application	Agricultural and Construction	Agricultural and Construction	Agricultural and Construction	Agricultural and Construction	Agricultural and Construction	Agricultural and Construction

Part Number	A1044	A1054	A1057	A1090	A12033	A12057
Description	Hose Assembly 3/8" X 34" (8F - 8F)	Hose Assembly 3/8" X 204" (08F - 08F)	Hose Assembly 3/8" X 216" (08F - 08F)	Hose Assembly 3/8" X 162" (08F - 08F)	Hose Assembly 3/8" X 92" (08F - 08F)	Hose Assembly 3/8" X 106" (08F - 08F)
Product Category	Hydraulic Hose	Hydraulic Hose	Hydraulic Hose	Hydraulic Hose	Hydraulic Hose	Hydraulic Hose
Product Form	Hose; Assembly	Hose; Assembly	Hose; Assembly	Hose; Assembly	Hose; Assembly	Hose; Assembly
I.D.	3/8" (9.525 mm)	3/8" (9.525 mm)	3/8" (9.525 mm)	3/8" (9.525 mm)	3/8" (9.525 mm)	3/8" (9.525 mm)
O.D.	.63" (16.002 mm)	.63" (16.002 mm)	.63" (16.002 mm)	.63" (16.002 mm)	.63" (16.002 mm)	.63" (16.002 mm)
Minimum Bend Radius	2" (5.08 cm)	2" (5.08 cm)	2" (5.08 cm)	2" (5.08 cm)	2" (5.08 cm)	2" (5.08 cm)
Working Pressure	3250 PSI (22407.96 kPa)	3250 PSI (22407.96 kPa)	3250 PSI (22407.96 kPa)	3250 PSI (22407.96 kPa)	3250 PSI (22407.96 kPa)	3250 PSI (22407.96 kPa)
Temperature Range	-40°F - +212°F (-40°C - +100°C)	-40°F - +212°F (-40°C - +100°C)	-40°F - +212°F (-40°C - +100°C)	-40°F - +212°F (-40°C - +100°C)	-40°F - +212°F (-40°C - +100°C)	-40°F - +212°F (-40°C - +100°C)
Material	Modified Nitrile Type C2	Modified Nitrile Type C2	Modified Nitrile Type C2	Modified Nitrile Type C2	Modified Nitrile Type C2	Modified Nitrile Type C2
Specialized Construction	High Tensile Steel Wire	High Tensile Steel Wire	High Tensile Steel Wire	High Tensile Steel Wire	High Tensile Steel Wire	High Tensile Steel Wire
Media	Hydraulic Fluid	Hydraulic Fluid	Hydraulic Fluid	Hydraulic Fluid	Hydraulic Fluid	Hydraulic Fluid
Application	Agricultural; Construction	Agricultural; Construction	Agricultural; Construction	Agricultural; Construction	Agricultural; Construction	Agricultural; Construction

HYDRAULIC HOSE INFORMATION

Part Number	A12063	A15013	A15019	A15020	A15024	A15025
Description	Hose Assembly 3/8" X 141" (08F - 08F)	Hose Assembly 3/8" X 32" (08F - 08F)	Hose Assembly 3/8" X 128" (08F - 08F)	Hose Assembly 3/8" X 38" (06F - 08F)	Hose Assembly 3/8" X 216" (08F - 10F)	Hose Assembly 3/8" X 197" (8F - 8F)
Product Category	Hydraulic Hose	Hydraulic Hose	Hydraulic Hose	Hydraulic Hose	Hydraulic Hose	Hydraulic Hose
Product Form	Hose; Assembly	Hose; Assembly	Hose; Assembly	Hose; Assembly	Hose; Assembly	Hose; Assembly
I.D.	3/8" (9.525 mm)	3/8" (9.525 mm)	3/8" (9.525 mm)	3/8" (9.525 mm)	3/8" (9.525 mm)	3/8" (9.525 mm)
O.D.	.63" (16.002 mm)	.63" (16.002 mm)	0.63" (16.002 mm)	0.63" (16.002 mm)	.63" (16.002 mm)	.63" (16.002 mm)
Minimum Bend Radius	2" (5.08 cm)	2" (5.08 cm)	2" (5.08 cm)	2" (5.08 cm)	2" (5.08 cm)	2" (5.08 cm)
Working Pressure	3250 PSI (22407.96 kPa)	3250 PSI (22407.96 kPa)	3250 psi (22407.96 kPa)	3250 psi (22407.96 kPa)	3250 PSI (22407.96 kPa)	3250 PSI (22407.96 kPa)
Temperature Range	-40°F - +212°F (-40°C - +100°C)	-40°F - +212°F (-40°C - +100°C)	-40°F - +212°F (-40°C - +100°C)	-40°F - +212°F (-40°C - +100°C)	-40°F - +212°F (-40°C - +100°C)	-40°F - +212°F (-40°C - +100°C)
Material	Modified Nitrile Type C2	Modified Nitrile Type C2	Modified Nitrile Type C2	Modified Nitrile Type C2	Modified Nitrile Type C2	Modified Nitrile Type C2
Specialized Construction	High Tensile Steel Wire	High Tensile Steel Wire	High Tensile Steel Wire	High Tensile Steel Wire	High Tensile Steel Wire	High Tensile Steel Wire
Media	Hydraulic Fluid	Hydraulic Fluid	Hydraulic Fluid	Hydraulic Fluid	Hydraulic Fluid	Hydraulic Fluid
Application	Agricultural and Construction	Agricultural and Construction	Agricultural and Construction	Agricultural and Construction	Agricultural and Construction	Agricultural and Construction

Part Number	A15026	A15032-182	A15032-228	A15032-333	A15033	A15034
Description	Hose Assembly 3/8" X 98" (8M - 8F)	Hose Assembly 3/8" X 182" (08F - 08F)	Hose Assembly 3/8" X 228" (08F - 08F)	Hose Assembly 3/8" X 333" (08F - 08F)	Hose Assembly 3/8" X 375" (08F - 08F)	Hose Assembly 3/8" X 56" (06F - 08F)
Product Category	Hydraulic Hose	Hydraulic Hose	Hydraulic Hose	Hydraulic Hose	Hydraulic Hose	Hydraulic Hose
Product Form	Hose; Assembly	Hose; Assembly	Hose; Assembly	Hose; Assembly	Hose; Assembly	Hose; Assembly
I.D.	3/8" (9.525 mm)	3/8" (9.525 mm)	3/8" (9.525 mm)	3/8" (9.525 mm)	3/8" (9.525 mm)	3/8" (9.525 mm)
O.D.	.63" (16.002 mm)	.63" (16.002 mm)	.63" (16.002 mm)	.63" (16.002 mm)	.63" (16.002 mm)	.63" (16.002 mm)
Minimum Bend Radius	2" (5.08 cm)	2" (5.08 cm)	2" (5.08 cm)	2" (5.08 cm)	2" (5.08 cm)	2" (5.08 cm)
Working Pressure	3250 PSI (22407.96 kPa)	3250 PSI (22407.96 kPa)	3250 PSI (22407.96 kPa)	3250 PSI (22407.96 kPa)	3250 PSI (22407.96 kPa)	3250 PSI (22407.96 kPa)
Temperature Range	-40°F - +212°F (-40°C - +100°C)	-40°F - +212°F (-40°C - +100°C)	-40°F - +212°F (-40°C - +100°C)	-40°F - +212°F (-40°C - +100°C)	-40°F - +212°F (-40°C - +100°C)	-40°F - +212°F (-40°C - +100°C)
Material	Modified Nitrile Type C2	Modified Nitrile Type C2	Modified Nitrile Type C2	Modified Nitrile Type C2	Modified Nitrile Type C2	Modified Nitrile Type C2
Specialized Construction	High Tensile Steel Wire	High Tensile Steel Wire	High Tensile Steel Wire	High Tensile Steel Wire	High Tensile Steel Wire	High Tensile Steel Wire
Media	Hydraulic Fluid	Hydraulic Fluid	Hydraulic Fluid	Hydraulic Fluid	Hydraulic Fluid	Hydraulic Fluid
Application	Agricultural; Construction	Agricultural; Construction	Agricultural; Construction	Agricultural; Construction	Agricultural; Construction	Agricultural; Construction

HYDRAULIC HOSE INFORMATION

Part Number	A15035-218	A15035-252	A15035-361	A15035-368	A15039	A15042
Description	Hose Assembly 3/8" X 218" (06F - 08F)	Hose Assembly 3/8" X 252" (06F - 08F)	Hose Assembly 3/8" X 361" (06F - 08F)	Hose Assembly 3/8" X 368" (06F - 08F)	Hose Assembly 3/8" X 98" (08F - 8F)	Hose Assembly 3/8" X 38" (8F - 10F)
Product Category	Hydraulic Hose	Hydraulic Hose	Hydraulic Hose	Hydraulic Hose	Hydraulic Hose	Hydraulic Hose
Product Form	Hose; Assembly	Hose; Assembly	Hose; Assembly	Hose; Assembly	Hose; Assembly	Hose; Assembly
I.D.	3/8" (9.525 mm)	3/8" (9.525 mm)	3/8" (9.525 mm)	3/8" (9.525 mm)	3/8" (9.525 mm)	3/8" (9.525 mm)
O.D.	.63" (16.002 mm)	.63" (16.002 mm)	.63" (16.002 mm)	.63" (16.002 mm)	.63" (16.002 mm)	.63" (16.002 mm)
Minimum Bend Radius	2" (5.08 cm)	2" (5.08 cm)	2" (5.08 cm)	2" (5.08 cm)	2" (5.08 cm)	2" (5.08 cm)
Working Pressure	3250 PSI (22407.96 kPa)	3250 PSI (22407.96 kPa)	3250 psi (22407.96 kPa)	3250 psi (22407.96 kPa)	3250 PSI (22407.96 kPa)	3250 PSI (22407.96 kPa)
Temperature Range	-40°F - +212°F (-40°C - +100°C)	-40°F - +212°F (-40°C - +100°C)	-40°F - +212°F (-40°C - +100°C)	-40°F - +212°F (-40°C - +100°C)	-40°F - +212°F (-40°C - +100°C)	-40°F - +212°F (-40°C - +100°C)
Material	Modified Nitrile Type C2	Modified Nitrile Type C2	Modified Nitrile Type C2	Modified Nitrile Type C2	Modified Nitrile Type C2	Modified Nitrile Type C2
Specialized Construction	High Tensile Steel Wire	High Tensile Steel Wire	High Tensile Steel Wire	High Tensile Steel Wire	High Tensile Steel Wire	High Tensile Steel Wire
Media	Hydraulic Fluid	Hydraulic Fluid	Hydraulic Fluid	Hydraulic Fluid	Hydraulic Fluid	Hydraulic Fluid
Application	Agricultural and Construction	Agricultural and Construction	Agricultural and Construction	Agricultural and Construction	Agricultural and Construction	Agricultural and Construction

Part Number	A15044	A15045	A1110	A15048	A15051	A3113
Description	Hose Assembly 3/8" X 36" (8F - 10F)	Hose Assembly 3/8" X 14" (08F - 08F)	Hose Assembly 1/4" x 150" (6F - 6F)	Hose Assembly 3/8" X 14" (08F - 10F)	Hose Assembly 3/8" X 377" (08F - 10F)	Hose Assembly 3/8" X 84" (08F - 08F)
Product Category	Hydraulic Hose	Hydraulic Hose	Hydraulic Hose	Hydraulic Hose	Hydraulic Hose	Hydraulic Hose
Product Form	Hose; Assembly	Hose; Assembly	Hose; Assembly	Hose; Assembly	Hose; Assembly	Hose; Assembly
I.D.	3/8" (9.525 mm)	3/8" (9.525 mm)	1/4" (6.35 mm)	3/8" (9.525 mm)	3/8" (9.525 mm)	3/8" (9.525 mm)
O.D.	.63" (16.002 mm)	.63" (16.002 mm)	.530" (13.46 mm)	.63" (16.002 mm)	.63" (16.002 mm)	.63" (16.002 mm)
Minimum Bend Radius	2" (5.08 cm)	2" (5.08 cm)	4" (10.16 cm)	2" (5.08 cm)	2" (5.08 cm)	2" (5.08 cm)
Working Pressure	3250 PSI (22407.96 kPa)	3250 PSI (22407.96 kPa)	3275 PSI (22580.33 kPa)	3250 PSI (22407.96 kPa)	3250 PSI (22407.96 kPa)	3250 PSI (22407.96 kPa)
Temperature Range	-40°F - +212°F (-40°C - +100°C)	-40°F - +212°F (-40°C - +100°C)	-40°F - +212°F (-40°C - +100°C)	-40°F - +212°F (-40°C - +100°C)	-40°F - +212°F (-40°C - +100°C)	-40°F - +212°F (-40°C - +100°C)
Material	Modified Nitrile Type C2	Modified Nitrile Type C2	Modified Nitrile Type C2	Modified Nitrile Type C2	Modified Nitrile Type C2	Modified Nitrile Type C2
Specialized Construction	High Tensile Steel Wire	High Tensile Steel Wire	High Tensile Steel Wire	High Tensile Steel Wire	High Tensile Steel Wire	High Tensile Steel Wire
Media	Hydraulic Fluid	Hydraulic Fluid	Hydraulic Fluid	Hydraulic Fluid	Hydraulic Fluid	Hydraulic Fluid
Application	Agricultural; Construction	Agricultural; Construction	Agricultural; Construction	Agricultural; Construction	Agricultural; Construction	Agricultural; Construction

HYDRAULIC HOSE INFORMATION

Part Number	A3199	A3118	A3136	A3139	A3140	A3156
Description	Hose Assembly 3/8" X 132" (08F - 08F)	Hose Assembly 3/8" X 80" (08F - 08F)	Hose Assembly 3/8" X 100" (08F - 08F)	Hose Assembly 3/8" X 254" (08F - 08F)	Hose Assembly 3/8" X 94" (08F - 8F)	Hose Assembly 3/8" X 68" (8F - 8F)
Product Category	Hydraulic Hose	Hydraulic Hose	Hydraulic Hose	Hydraulic Hose	Hydraulic Hose	Hydraulic Hose
Product Form	Hose; Assembly	Hose; Assembly	Hose; Assembly	Hose; Assembly	Hose; Assembly	Hose; Assembly
I.D.	3/8" (9.525 mm)	3/8" (9.525 mm)	3/8" (9.525 mm)	3/8" (9.525 mm)	3/8" (9.525 mm)	3/8" (9.525 mm)
O.D.	.63" (16.002 mm)	.63" (16.002 mm)	0.63" (16.002 mm)	0.63" (16.002 mm)	.63" (16.002 mm)	.63" (16.002 mm)
Minimum Bend Radius	2" (5.08 cm)	2" (5.08 cm)	2" (5.08 cm)	2" (5.08 cm)	2" (5.08 cm)	2" (5.08 cm)
Working Pressure	3250 PSI (22407.96 kPa)	3250 PSI (22407.96 kPa)	3250 psi (22407.96 kPa)	3250 psi (22407.96 kPa)	3250 PSI (22407.96 kPa)	3250 PSI (22407.96 kPa)
Temperature Range	-40°F - +212°F (-40°C - +100°C)	-40°F - +212°F (-40°C - +100°C)	-40°F - +212°F (-40°C - +100°C)	-40°F - +212°F (-40°C - +100°C)	-40°F - +212°F (-40°C - +100°C)	-40°F - +212°F (-40°C - +100°C)
Material	Modified Nitrile Type C2	Modified Nitrile Type C2	Modified Nitrile Type C2	Modified Nitrile Type C2	Modified Nitrile Type C2	Modified Nitrile Type C2
Specialized Construction	High Tensile Steel Wire	High Tensile Steel Wire	High Tensile Steel Wire	High Tensile Steel Wire	High Tensile Steel Wire	High Tensile Steel Wire
Media	Hydraulic Fluid	Hydraulic Fluid	Hydraulic Fluid	Hydraulic Fluid	Hydraulic Fluid	Hydraulic Fluid
Application	Agricultural and Construction	Agricultural and Construction	Agricultural and Construction	Agricultural and Construction	Agricultural and Construction	Agricultural and Construction

Part Number	A3170	A1155	A12742	A12759	A12778	A12782
Description	Hose Assembly 3/8" X 81" (8F - 8F)	Hose Assembly 1/4" x 48" (6F - 6F)	Hose Assembly 1/2" x 216" (8F - 10F)	Hose Assembly 1/2" x 36" (8F - 10F)	Hose Assembly 1/2" x 186" (10F - 10F)	Hose Assembly 1/2" x 36" (8M - 10F)
Product Category	Hydraulic Hose	Hydraulic Hose	Hydraulic Hose	Hydraulic Hose	Hydraulic Hose	Hydraulic Hose
Product Form	Hose; Assembly	Hose; Assembly	Hose; Assembly	Hose; Assembly	Hose; Assembly	Hose; Assembly
I.D.	3/8" (9.525 mm)	1/4" (6.35 mm)	1/2" (12.7 mm)	1/2" (12.7 mm)	1/2" (12.7 mm)	1/2" (12.7 mm)
O.D.	.63" (16.002 mm)	.530" (13.46 mm)	.80" (20.32 mm)	.80" (20.32 mm)	.80" (20.32 mm)	.80" (20.32 mm)
Minimum Bend Radius	2" (5.08 cm)	4" (10.16 cm)	2.8" (7.11 cm)	2.8" (7.11 cm)	2.8" (7.11 cm)	2.8" (7.11 cm)
Working Pressure	3250 PSI (22407.96 kPa)	3275 PSI (22580.33 kPa)	3250 PSI (22407.96 kPa)	3250 PSI (22407.96 kPa)	3250 PSI (22407.96 kPa)	3250 PSI (22407.96 kPa)
Temperature Range	-40°F - +212°F (-40°C - +100°C)	-40°F - +212°F (-40°C - +100°C)	-40°F - +212°F (-40°C - +100°C)	-40°F - +212°F (-40°C - +100°C)	-40°F - +212°F (-40°C - +100°C)	-40°F - +212°F (-40°C - +100°C)
Material	Modified Nitrile Type C2	Modified Nitrile Type C2	Modified Nitrile Type C2	Modified Nitrile Type C2	Modified Nitrile Type C2	Modified Nitrile Type C2
Specialized Construction	High Tensile Steel Wire	High Tensile Steel Wire	High Tensile Steel Wire	High Tensile Steel Wire	High Tensile Steel Wire	High Tensile Steel Wire
Media	Hydraulic Fluid	Hydraulic Fluid	Hydraulic Fluid	Hydraulic Fluid	Hydraulic Fluid	Hydraulic Fluid
Application	Agricultural; Construction	Agricultural; Construction	Agricultural; Construction	Agricultural; Construction	Agricultural; Construction	Agricultural; Construction

HYDRAULIC HOSE INFORMATION

Part Number	A15032-324	A3114	A12783	A12784	A12785	A12786
Description	Hose Assembly 3/8" X 324" (08F - 08F)	Hose Assembly 3/8" X 156" (08F - 08F)	Hose Assembly 1/2" x 41" (8F - 10F)	Hose Assembly 1/2" x 48" (8F - 10F)	Hose Assembly 1/2" x 38" (8F - 10F)	Hose Assembly 1/2" x 50" (8F - 10F)
Product Category	Hydraulic Hose	Hydraulic Hose	Hydraulic Hose	Hydraulic Hose	Hydraulic Hose	Hydraulic Hose
Product Form	Hose; Assembly	Hose; Assembly	Hose; Assembly	Hose; Assembly	Hose; Assembly	Hose; Assembly
I.D.	3/8" (9.525 mm)	3/8" (9.525 mm)	1/2" (12.7 mm)	1/2" (12.7 mm)	1/2" (12.7 mm)	1/2" (12.7 mm)
O.D.	.63" (16.002 mm)	.63" (16.002 mm)	.80" (20.32 mm)	.80" (20.32 mm)	.80" (20.32 mm)	.80" (20.32 mm)
Minimum Bend Radius	2" (5.08 cm)	2" (5.08 cm)	2.8" (7.11 cm)	2.8" (7.11 cm)	2.8" (7.11 cm)	2.8" (7.11 cm)
Working Pressure	3250 PSI (22407.96 kPa)	3250 PSI (22407.96 kPa)	3250 PSI (22407.96 kPa)	3250 PSI (22407.96 kPa)	3250 PSI (22407.96 kPa)	3250 PSI (22407.96 kPa)
Temperature Range	-40°F - +212°F (-40°C - +100°C)	-40°F - +212°F (-40°C - +100°C)	-40°F - +212°F (-40°C - +100°C)	-40°F - +212°F (-40°C - +100°C)	-40°F - +212°F (-40°C - +100°C)	-40°F - +212°F (-40°C - +100°C)
Material	Modified Nitrile Type C2	Modified Nitrile Type C2	Modified Nitrile Type C2	Modified Nitrile Type C2	Modified Nitrile Type C2	Modified Nitrile Type C2
Specialized Construction	High Tensile Steel Wire	High Tensile Steel Wire	High Tensile Steel Wire	High Tensile Steel Wire	High Tensile Steel Wire	High Tensile Steel Wire
Media	Hydraulic Fluid	Hydraulic Fluid	Hydraulic Fluid	Hydraulic Fluid	Hydraulic Fluid	Hydraulic Fluid
Application	Agricultural and Construction	Agricultural and Construction	Agricultural; Construction	Agricultural; Construction	Agricultural; Construction	Agricultural; Construction

Part Number	A12787	A12788	A11469	A11470	A11471	A11481-180
Description	Hose Assembly 1/2" x 96" (8M - 8F)	Hose Assembly 1/2" x 98" (8M - 10F)	Hose Assembly 5/8" X 98" (08M - 12F)	Hose Assembly 5/8" X 98" (08M - 12F)	Hose Assembly 5/8" X 98" (08M - 10F)	Hose Assembly 5/8" X 180" (10F - 10F)
Product Category	Hydraulic Hose	Hydraulic Hose	Hydraulic Hose	Hydraulic Hose	Hydraulic Hose	Hydraulic Hose
Product Form	Hose; Assembly	Hose; Assembly	Hose; Assembly	Hose; Assembly	Hose; Assembly	Hose; Assembly
I.D.	1/2" (12.7 mm)	1/2" (12.7 mm)	5/8" (15.875 mm)	5/8" (15.875 mm)	5/8" (15.875 mm)	5/8" (15.875 mm)
O.D.	.80" (20.32 mm)	.80" (20.32 mm)	.99" (25.146 mm)	.99" (25.146 mm)	.99" (25.146 mm)	.99" (25.146 mm)
Minimum Bend Radius	2.8" (7.11 cm)	2.8" (7.11 cm)	2" (5.08 cm)	2" (5.08 cm)	2" (5.08 cm)	2" (5.08 cm)
Working Pressure	3250 PSI (22407.96 kPa)	3250 PSI (22407.96 kPa)	3250 PSI (22407.96 kPa)	3250 PSI (22407.96 kPa)	3250 PSI (22407.96 kPa)	3250 PSI (22407.96 kPa)
Temperature Range	-40°F - +212°F (-40°C - +100°C)	-40°F - +212°F (-40°C - +100°C)	-40°F - +212°F (-40°C - +100°C)	-40°F - +212°F (-40°C - +100°C)	-40°F - +212°F (-40°C - +100°C)	-40°F - +212°F (-40°C - +100°C)
Material	Modified Nitrile Type C2	Modified Nitrile Type C2	Modified Nitrile Type C2	Modified Nitrile Type C2	Modified Nitrile Type C2	Modified Nitrile Type C2
Specialized Construction	High Tensile Steel Wire	High Tensile Steel Wire	High Tensile Steel Wire	High Tensile Steel Wire	High Tensile Steel Wire	High Tensile Steel Wire
Media	Hydraulic Fluid	Hydraulic Fluid	Hydraulic Fluid	Hydraulic Fluid	Hydraulic Fluid	Hydraulic Fluid
Application	Agricultural; Construction	Agricultural; Construction	Agricultural; Construction	Agricultural; Construction	Agricultural; Construction	Agricultural; Construction

HYDRAULIC HOSE INFORMATION

Part Number	A11481-228	A11481-329	A11482-224	A11482-258	A11482-361	A11482-368
Description	Hose Assembly 5/8" X 227" (10F - 10F)	Hose Assembly 5/8" X 329" (10F - 10F)	Hose Assembly 5/8" X 224" (10F - 12F)	Hose Assembly 5/8" X 258" (10F - 12F)	Hose Assembly 5/8" X 361" (10F - 12F)	Hose Assembly 5/8" X 368" (10F - 12F)
Product Category	Hydraulic Hose	Hydraulic Hose	Hydraulic Hose	Hydraulic Hose	Hydraulic Hose	Hydraulic Hose
Product Form	Hose; Assembly	Hose; Assembly	Hose; Assembly	Hose; Assembly	Hose; Assembly	Hose; Assembly
I.D.	5/8" (15.875 mm)	5/8" (15.875 mm)	5/8" (15.875 mm)	5/8" (15.875 mm)	5/8" (15.875 mm)	5/8" (15.875 mm)
O.D.	.99" (25.146 mm)	.99" (25.146 mm)	.99" (25.146 mm)	.99" (25.146 mm)	.99" (25.146 mm)	.99" (25.146 mm)
Minimum Bend Radius	2" (5.08 cm)	2" (5.08 cm)	2" (5.08 cm)	2" (5.08 cm)	2" (5.08 cm)	2" (5.08 cm)
Working Pressure	3250 PSI (22407.96 kPa)	3250 PSI (22407.96 kPa)	3250 PSI (22407.96 kPa)	3250 PSI (22407.96 kPa)	3250 PSI (22407.96 kPa)	3250 PSI (22407.96 kPa)
Temperature Range	-40°F - +212°F (-40°C - +100°C)	-40°F - +212°F (-40°C - +100°C)	-40°F - +212°F (-40°C - +100°C)	-40°F - +212°F (-40°C - +100°C)	-40°F - +212°F (-40°C - +100°C)	-40°F - +212°F (-40°C - +100°C)
Material	Modified Nitrile Type C2	Modified Nitrile Type C2	Modified Nitrile Type C2	Modified Nitrile Type C2	Modified Nitrile Type C2	Modified Nitrile Type C2
Specialized Construction	High Tensile Steel Wire	High Tensile Steel Wire	High Tensile Steel Wire	High Tensile Steel Wire	High Tensile Steel Wire	High Tensile Steel Wire
Media	Hydraulic Fluid	Hydraulic Fluid	Hydraulic Fluid	Hydraulic Fluid	Hydraulic Fluid	Hydraulic Fluid
Application	Agricultural; Construction	Agricultural; Construction	Agricultural; Construction	Agricultural; Construction	Agricultural; Construction	Agricultural; Construction

Part Number	A11483	A11484	A11485-174	A11485-204	A11485-338	A11486
Description	Hose Assembly 5/8" X 86" (12F - 12F)	Hose Assembly 5/8" X 168" (12F - 12F)	Hose Assembly 5/8" X 174" (12F - 12F)	Hose Assembly 5/8" X 204" (12F - 12F)	Hose Assembly 5/8" X 338" (12F - 12F)	Hose Assembly 5/8" X 109" (12F - 12F)
Product Category	Hydraulic Hose	Hydraulic Hose	Hydraulic Hose	Hydraulic Hose	Hydraulic Hose	Hydraulic Hose
Product Form	Hose; Assembly	Hose; Assembly	Hose; Assembly	Hose; Assembly	Hose; Assembly	Hose; Assembly
I.D.	5/8" (15.875 mm)	5/8" (15.875 mm)	5/8" (15.875 mm)	5/8" (15.875 mm)	5/8" (15.875 mm)	5/8" (15.875 mm)
O.D.	.99" (25.146 mm)	.99" (25.146 mm)	.99" (25.146 mm)	.99" (25.146 mm)	.99" (25.146 mm)	.99" (25.146 mm)
Minimum Bend Radius	2" (5.08 cm)	2" (5.08 cm)	2" (5.08 cm)	2" (5.08 cm)	2" (5.08 cm)	2" (5.08 cm)
Working Pressure	3250 PSI (22407.96 kPa)	3250 PSI (22407.96 kPa)	3250 PSI (22407.96 kPa)	3250 PSI (22407.96 kPa)	3250 PSI (22407.96 kPa)	3250 PSI (22407.96 kPa)
Temperature Range	-40°F - +212°F (-40°C - +100°C)	-40°F - +212°F (-40°C - +100°C)	-40°F - +212°F (-40°C - +100°C)	-40°F - +212°F (-40°C - +100°C)	-40°F - +212°F (-40°C - +100°C)	-40°F - +212°F (-40°C - +100°C)
Material	Modified Nitrile Type C2	Modified Nitrile Type C2	Modified Nitrile Type C2	Modified Nitrile Type C2	Modified Nitrile Type C2	Modified Nitrile Type C2
Specialized Construction	High Tensile Steel Wire	High Tensile Steel Wire	High Tensile Steel Wire	High Tensile Steel Wire	High Tensile Steel Wire	High Tensile Steel Wire
Media	Hydraulic Fluid	Hydraulic Fluid	Hydraulic Fluid	Hydraulic Fluid	Hydraulic Fluid	Hydraulic Fluid
Application	Agricultural; Construction	Agricultural; Construction	Agricultural; Construction	Agricultural; Construction	Agricultural; Construction	Agricultural; Construction

HYDRAULIC HOSE INFORMATION

Part Number	A18627	A18625	A18629-174	A18629-180	A18629-204	A18629-228
Description	Hose Assembly ½" x 180" (8F - 10F)	Hose Assembly ½" x 162" (8F - 10F)	Hose Assembly ½" x 174" (8F - 10F)	Hose Assembly ½" x 180" (10F - 10F)	Hose Assembly ½" x 204" (10F - 10F)	Hose Assembly ½" x 228" (10F - 10F)
Product Category	Hydraulic Hose	Hydraulic Hose	Hydraulic Hose	Hydraulic Hose	Hydraulic Hose	Hydraulic Hose
Product Form	Hose; Assembly	Hose; Assembly	Hose; Assembly	Hose; Assembly	Hose; Assembly	Hose; Assembly
I.D.	½" (12.7 mm)	½" (12.7 mm)	½" (12.7 mm)	½" (12.7 mm)	½" (12.7 mm)	½" (12.7 mm)
O.D.	.80" (20.32 mm)	.80" (20.32 mm)	.80" (20.32 mm)	.80" (20.32 mm)	.80" (20.32 mm)	.80" (20.32 mm)
Minimum Bend Radius	2.8" (7.11 cm)	2.8" (7.11 cm)	2.8" (7.11 cm)	2.8" (7.11 cm)	2.8" (7.11 cm)	2.8" (7.11 cm)
Working Pressure	3250 PSI (22407.96 kPa)	3250 PSI (22407.96 kPa)	3250 PSI (22407.96 kPa)	3250 PSI (22407.96 kPa)	3250 PSI (22407.96 kPa)	3250 PSI (22407.96 kPa)
Temperature Range	-40°F - +212°F (-40°C - +100°C)	-40°F - +212°F (-40°C - +100°C)	-40°F - +212°F (-40°C - +100°C)	-40°F - +212°F (-40°C - +100°C)	-40°F - +212°F (-40°C - +100°C)	-40°F - +212°F (-40°C - +100°C)
Material	Modified Nitrile Type C2	Modified Nitrile Type C2	Modified Nitrile Type C2	Modified Nitrile Type C2	Modified Nitrile Type C2	Modified Nitrile Type C2
Specialized Construction	High Tensile Steel Wire	High Tensile Steel Wire	High Tensile Steel Wire	High Tensile Steel Wire	High Tensile Steel Wire	High Tensile Steel Wire
Media	Hydraulic Fluid	Hydraulic Fluid	Hydraulic Fluid	Hydraulic Fluid	Hydraulic Fluid	Hydraulic Fluid
Application	Agricultural; Construction	Agricultural; Construction	Agricultural; Construction	Agricultural; Construction	Agricultural; Construction	Agricultural; Construction

Part Number	A18629-320	A18629-338	A18630-224	A18630-258	A18630-361	A18630-368
Description	Hose Assembly ½" x 320" (10F - 10F)	Hose Assembly ½" x 338" (10F - 10F)	Hose Assembly ½" x 224" (8F - 8F)	Hose Assembly ½" x 258" (8F - 8F)	Hose Assembly ½" x 361" (8F - 8F)	Hose Assembly ½" x 368" (8F - 8F)
Product Category	Hydraulic Hose	Hydraulic Hose	Hydraulic Hose	Hydraulic Hose	Hydraulic Hose	Hydraulic Hose
Product Form	Hose; Assembly	Hose; Assembly	Hose; Assembly	Hose; Assembly	Hose; Assembly	Hose; Assembly
I.D.	½" (12.7 mm)	½" (12.7 mm)	½" (12.7 mm)	½" (12.7 mm)	½" (12.7 mm)	½" (12.7 mm)
O.D.	.80" (20.32 mm)	.80" (20.32 mm)	.80" (20.32 mm)	.80" (20.32 mm)	.80" (20.32 mm)	.80" (20.32 mm)
Minimum Bend Radius	2.8" (7.11 cm)	2.8" (7.11 cm)	2.8" (7.11 cm)	2.8" (7.11 cm)	2.8" (7.11 cm)	2.8" (7.11 cm)
Working Pressure	3250 PSI (22407.96 kPa)	3250 PSI (22407.96 kPa)	3250 PSI (22407.96 kPa)	3250 PSI (22407.96 kPa)	3250 PSI (22407.96 kPa)	3250 PSI (22407.96 kPa)
Temperature Range	-40°F - +212°F (-40°C - +100°C)	-40°F - +212°F (-40°C - +100°C)	-40°F - +212°F (-40°C - +100°C)	-40°F - +212°F (-40°C - +100°C)	-40°F - +212°F (-40°C - +100°C)	-40°F - +212°F (-40°C - +100°C)
Material	Modified Nitrile Type C2	Modified Nitrile Type C2	Modified Nitrile Type C2	Modified Nitrile Type C2	Modified Nitrile Type C2	Modified Nitrile Type C2
Specialized Construction	High Tensile Steel Wire	High Tensile Steel Wire	High Tensile Steel Wire	High Tensile Steel Wire	High Tensile Steel Wire	High Tensile Steel Wire
Media	Hydraulic Fluid	Hydraulic Fluid	Hydraulic Fluid	Hydraulic Fluid	Hydraulic Fluid	Hydraulic Fluid
Application	Agricultural; Construction	Agricultural; Construction	Agricultural; Construction	Agricultural; Construction	Agricultural; Construction	Agricultural; Construction

HYDRAULIC HOSE INFORMATION

Part Number	A18635	A18636	A18638	A18639	A18640	A18641
Description	Hose Assembly ½" x 86" (10F - 10F)	Hose Assembly ½" x 109" (10F - 10F)	Hose Assembly ½" x 160" (10F - 10F)	Hose Assembly ½" x 24" (8F - 10F)	Hose Assembly ½" x 52" (10M - 10F)	Hose Assembly ½" x 48" (8M - 10F)
Product Category	Hydraulic Hose	Hydraulic Hose	Hydraulic Hose	Hydraulic Hose	Hydraulic Hose	Hydraulic Hose
Product Form	Hose; Assembly	Hose; Assembly	Hose; Assembly	Hose; Assembly	Hose; Assembly	Hose; Assembly
I.D.	½" (12.7 mm)	½" (12.7 mm)	½" (12.7 mm)	½" (12.7 mm)	½" (12.7 mm)	½" (12.7 mm)
O.D.	.80" (20.32 mm)	.80" (20.32 mm)	.80" (20.32 mm)	.80" (20.32 mm)	.80" (20.32 mm)	.80" (20.32 mm)
Minimum Bend Radius	2.8" (7.11 cm)	2.8" (7.11 cm)	2.8" (7.11 cm)	2.8" (7.11 cm)	2.8" (7.11 cm)	2.8" (7.11 cm)
Working Pressure	3250 PSI (22407.96 kPa)	3250 PSI (22407.96 kPa)	3250 PSI (22407.96 kPa)	3250 PSI (22407.96 kPa)	3250 PSI (22407.96 kPa)	3250 PSI (22407.96 kPa)
Temperature Range	-40°F - +212°F (-40°C - +100°C)	-40°F - +212°F (-40°C - +100°C)	-40°F - +212°F (-40°C - +100°C)	-40°F - +212°F (-40°C - +100°C)	-40°F - +212°F (-40°C - +100°C)	-40°F - +212°F (-40°C - +100°C)
Material	Modified Nitrile Type C2	Modified Nitrile Type C2	Modified Nitrile Type C2	Modified Nitrile Type C2	Modified Nitrile Type C2	Modified Nitrile Type C2
Specialized Construction	High Tensile Steel Wire	High Tensile Steel Wire	High Tensile Steel Wire	High Tensile Steel Wire	High Tensile Steel Wire	High Tensile Steel Wire
Media	Hydraulic Fluid	Hydraulic Fluid	Hydraulic Fluid	Hydraulic Fluid	Hydraulic Fluid	Hydraulic Fluid
Application	Agricultural; Construction	Agricultural; Construction	Agricultural; Construction	Agricultural; Construction	Agricultural; Construction	Agricultural; Construction

Part Number	A18646	A18652	A18656	A18657	A7607	A7652
Description	Hose Assembly ½" x 52" (10F - 10F)	Hose Assembly ½" x 30" (8M - 10F)	Hose Assembly ½" x 217" (10F - 12F)	Hose Assembly ½" x 377" (10F - 12F)	Hose Assembly ¼" x 187" (6F - 6F)	Hose Assembly ¼" x 224" (6F - 6F)
Product Category	Hydraulic Hose	Hydraulic Hose	Hydraulic Hose	Hydraulic Hose	Hydraulic Hose	Hydraulic Hose
Product Form	Hose; Assembly	Hose; Assembly	Hose; Assembly	Hose; Assembly	Hose; Assembly	Hose; Assembly
I.D.	½" (12.7 mm)	½" (12.7 mm)	½" (12.7 mm)	½" (12.7 mm)	¼" (6.35 mm)	¼" (6.35 mm)
O.D.	.80" (20.32 mm)	.80" (20.32 mm)	.80" (20.32 mm)	.80" (20.32 mm)	.530" (13.46 mm)	.530" (13.46 mm)
Minimum Bend Radius	2.8" (7.11 cm)	2.8" (7.11 cm)	2.8" (7.11 cm)	2.8" (7.11 cm)	4" (10.16 cm)	4" (10.16 cm)
Working Pressure	3250 PSI (22407.96 kPa)	3250 PSI (22407.96 kPa)	3250 PSI (22407.96 kPa)	3250 PSI (22407.96 kPa)	3275 PSI (22580.33 kPa)	3275 PSI (22580.33 kPa)
Temperature Range	-40°F - +212°F (-40°C - +100°C)	-40°F - +212°F (-40°C - +100°C)	-40°F - +212°F (-40°C - +100°C)	-40°F - +212°F (-40°C - +100°C)	-40°F - +212°F (-40°C - +100°C)	-40°F - +212°F (-40°C - +100°C)
Material	Modified Nitrile Type C2	Modified Nitrile Type C2	Modified Nitrile Type C2	Modified Nitrile Type C2	Modified Nitrile Type C2	Modified Nitrile Type C2
Specialized Construction	High Tensile Steel Wire	High Tensile Steel Wire	High Tensile Steel Wire	High Tensile Steel Wire	High Tensile Steel Wire	High Tensile Steel Wire
Media	Hydraulic Fluid	Hydraulic Fluid	Hydraulic Fluid	Hydraulic Fluid	Hydraulic Fluid	Hydraulic Fluid
Application	Agricultural; Construction	Agricultural; Construction	Agricultural; Construction	Agricultural; Construction	Agricultural; Construction	Agricultural; Construction

HYDRAULIC HOSE INFORMATION



Part Number	A7658	A7668	A12789	A8248	A8264	A8280
Description	Hose Assembly 1/4" x 58" (6F - 6F)	Hose Assembly 1/4" x 76" (6F - 6F)	Hose Assembly 1/2" x 98" (8M - 8F)	Hose Assembly 1/2" x 168" (10F - 10F)	Hose Assembly 1/2" x 120" (10M - 10F)	Hose Assembly 1/2" x 54" (10F+ - 10F)
Product Category	Hydraulic Hose	Hydraulic Hose	Hydraulic Hose	Hydraulic Hose	Hydraulic Hose	Hydraulic Hose
Product Form	Hose; Assembly	Hose; Assembly	Hose; Assembly	Hose; Assembly	Hose; Assembly	Hose; Assembly
I.D.	1/4" (6.35 mm)	1/4" (6.35 mm)	1/2" (12.7 mm)	1/2" (12.7 mm)	1/2" (12.7 mm)	1/2" (12.7 mm)
O.D.	.530" (13.46 mm)	.530" (13.46 mm)	.80" (20.32 mm)	.80" (20.32 mm)	.80" (20.32 mm)	.80" (20.32 mm)
Minimum Bend Radius	4" (10.16 cm)	4" (10.16 cm)	2.8" (7.11 cm)	2.8" (7.11 cm)	2.8" (7.11 cm)	2.8" (7.11 cm)
Working Pressure	3275 PSI (22580.33 kPa)	3275 PSI (22580.33 kPa)	3250 PSI (22407.96 kPa)	3250 PSI (22407.96 kPa)	3250 PSI (22407.96 kPa)	3250 PSI (22407.96 kPa)
Temperature Range	-40°F - +212°F (-40°C - +100°C)	-40°F - +212°F (-40°C - +100°C)	-40°F - +212°F (-40°C - +100°C)	-40°F - +212°F (-40°C - +100°C)	-40°F - +212°F (-40°C - +100°C)	-40°F - +212°F (-40°C - +100°C)
Material	Modified Nitrile Type C2	Modified Nitrile Type C2	Modified Nitrile Type C2	Modified Nitrile Type C2	Modified Nitrile Type C2	Modified Nitrile Type C2
Specialized Construction	High Tensile Steel Wire	High Tensile Steel Wire	High Tensile Steel Wire	High Tensile Steel Wire	High Tensile Steel Wire	High Tensile Steel Wire
Media	Hydraulic Fluid	Hydraulic Fluid	Hydraulic Fluid	Hydraulic Fluid	Hydraulic Fluid	Hydraulic Fluid
Application	Agricultural; Construction	Agricultural; Construction	Agricultural; Construction	Agricultural; Construction	Agricultural; Construction	Agricultural; Construction



Part Number	A8282	A1118	A1140	A18629-329	A12790	A12792
Description	Hose Assembly 1/2" x 190" (10F - 10F)	Hose Assembly 1/4" x 295" (6F - 6F)	Hose Assembly 1/4" x 52" (6F - 6F)	Hose Assembly 1/2" x 329" (10F - 10F)	Hose Assembly 1/2" x 28" (8F - 10F)	Hose Assembly 1/2" x 146" (10F - 10F)
Product Category	Hydraulic Hose	Hydraulic Hose	Hydraulic Hose	Hydraulic Hose	Hydraulic Hose	Hydraulic Hose
Product Form	Hose; Assembly	Hose; Assembly	Hose; Assembly	Hose; Assembly	Hose; Assembly	Hose; Assembly
I.D.	1/2" (12.7 mm)	1/4" (6.35 mm)	1/4" (6.35 mm)	1/2" (12.7 mm)	1/2" (12.7 mm)	1/2" (12.7 mm)
O.D.	.80" (20.32 mm)	.530" (13.46 mm)	.530" (13.46 mm)	.80" (20.32 mm)	.80" (20.32 mm)	.80" (20.32 mm)
Minimum Bend Radius	2.8" (7.11 cm)	4" (10.16 cm)	4" (10.16 cm)	2.8" (7.11 cm)	2.8" (7.11 cm)	2.8" (7.11 cm)
Working Pressure	3250 PSI (22407.96 kPa)	3275 PSI (22580.33 kPa)	3275 PSI (22580.33 kPa)	3250 PSI (22407.96 kPa)	3250 PSI (22407.96 kPa)	3250 PSI (22407.96 kPa)
Temperature Range	-40°F - +212°F (-40°C - +100°C)	-40°F - +212°F (-40°C - +100°C)	-40°F - +212°F (-40°C - +100°C)	-40°F - +212°F (-40°C - +100°C)	-40°F - +212°F (-40°C - +100°C)	-40°F - +212°F (-40°C - +100°C)
Material	Modified Nitrile Type C2	Modified Nitrile Type C2	Modified Nitrile Type C2	Modified Nitrile Type C2	Modified Nitrile Type C2	Modified Nitrile Type C2
Specialized Construction	High Tensile Steel Wire	High Tensile Steel Wire	High Tensile Steel Wire	High Tensile Steel Wire	High Tensile Steel Wire	High Tensile Steel Wire
Media	Hydraulic Fluid	Hydraulic Fluid	Hydraulic Fluid	Hydraulic Fluid	Hydraulic Fluid	Hydraulic Fluid
Application	Agricultural; Construction	Agricultural; Construction	Agricultural; Construction	Agricultural; Construction	Agricultural; Construction	Agricultural; Construction

HYDRAULIC HOSE INFORMATION

Part Number	A12793	A12795	A12799	A1420	A1467
Description	Hose Assembly ½" x 131" (10F - 10F)	Hose Assembly ½" x 123" (10F - 10F)	Hose Assembly ½" x 31" (8F - 10F)	Hose Assembly ½" x 48" (10F - 10F)	Hose Assembly ½" x 120" (10F - 10F)
Product Category	Hydraulic Hose	Hydraulic Hose	Hydraulic Hose	Hydraulic Hose	Hydraulic Hose
Product Form	Hose; Assembly	Hose; Assembly	Hose; Assembly	Hose; Assembly	Hose; Assembly
I.D.	½" (12.7 mm)	½" (12.7 mm)	½" (12.7 mm)	½" (12.7 mm)	½" (12.7 mm)
O.D.	.80" (20.32 mm)	.80" (20.32 mm)	.80" (20.32 mm)	.80" (20.32 mm)	.80" (20.32 mm)
Minimum Bend Radius	2.8" (7.11 cm)	2.8" (7.11 cm)	2.8" (7.11 cm)	2.8" (7.11 cm)	2.8" (7.11 cm)
Working Pressure	3250 PSI (22407.96 kPa)	3250 PSI (22407.96 kPa)	3250 PSI (22407.96 kPa)	3250 PSI (22407.96 kPa)	3250 PSI (22407.96 kPa)
Temperature Range	-40°F - +212°F (-40°C - +100°C)	-40°F - +212°F (-40°C - +100°C)	-40°F - +212°F (-40°C - +100°C)	-40°F - +212°F (-40°C - +100°C)	-40°F - +212°F (-40°C - +100°C)
Material	Modified Nitrile Type C2	Modified Nitrile Type C2	Modified Nitrile Type C2	Modified Nitrile Type C2	Modified Nitrile Type C2
Specialized Construction	High Tensile Steel Wire	High Tensile Steel Wire	High Tensile Steel Wire	High Tensile Steel Wire	High Tensile Steel Wire
Media	Hydraulic Fluid	Hydraulic Fluid	Hydraulic Fluid	Hydraulic Fluid	Hydraulic Fluid
Application	Agricultural; Con- struction	Agricultural; Con- struction	Agricultural; Con- struction	Agricultural; Con- struction	Agricultural; Con- struction

TRANSPORTING PLANTER

 WARNING	<p>Uncontrolled movement of equipment can cause loss of control and could result in death, serious injury, or damage to property and equipment. Install all safety pins before transporting equipment.</p>
	

 WARNING	<p>Uncontrolled machine movement can crush or cause loss of control resulting in death, serious injury, or damage to property and equipment. Install all safety lockup devices before working under or transporting this equipment.</p>
	

 WARNING	<p>Transporting planter with hoppers over half full or unevenly loaded can cause loss of control and could result in death, serious injury, or damage to property and equipment. Properly load planter when transporting. Be aware of extra transport weight, and road conditions and limits.</p>
--	---

 WARNING	<p>To avoid unintended movement of axle during transport, return all SCV controls to the neutral position before transporting machine. DO NOT operate any hydraulic function while transporting machine. Doing so could result in death, serious injury, or damage to property and equipment.</p>
--	--

 WARNING	<p>Transport axle can lower from transport position without the use of any controller, causing death, serious injury, or damage to property and equipment. Do not operate any hydraulic function while transporting the planter. Make sure all transport safety lockups are installed on the four transport cylinders and all SCV controls are in their neutral state before transporting, storing and working on the planter.</p>
--	--

Make sure safety/warning lights, reflective decals, and SMV sign are in place and visible before transporting machine on public roads. It is your responsibility to check and comply with all federal, state/provincial, and local regulations.

Be aware of road and bridge weight limits. Allow for additional weight of added options and any additional material or substances that have been added to the machine.

LEVEL PLANTER

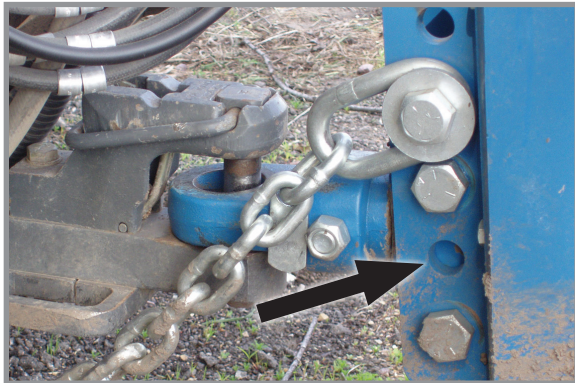

Clevis Adjustment Holes

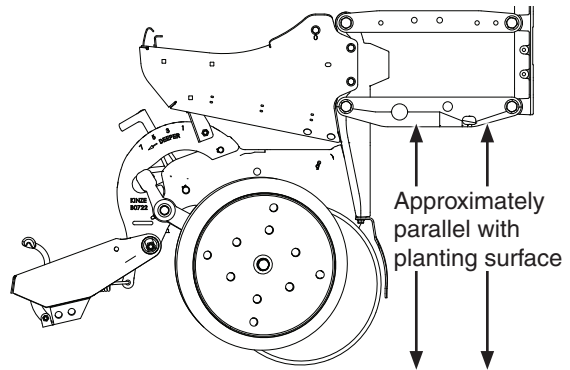

Level Row Units

Toolbar should operate at 23"-25" (58 - 63 cm) height from planting surface. Tire pressures must be maintained at pressures specified for planter to operate level laterally. Check toolbar and row unit parallel arms are level front to back with planter lowered to proper operating height.

On models equipped with drawbar hitch, five holes in the hitch bracket allow clevis to be raised or lowered. Clevis may be turned over for a finer adjustment between mounting holes. Torque hardware to 840 ft-lb (1138.8 N-m).

On models equipped with a 2-point hitch, the hitch is adjusted by the tractor 2-point hitch to achieve hitch level to slightly uphill.

Field and actual planting conditions determine which wheel settings to use to ensure row unit parallel arms are approximately parallel with planting surface. If planting in extremely soft soil conditions it may be necessary to move ground drive tires to lower sets of mounting holes. To allow adequate drive force after lowering the ground drive tires, it may be necessary to lower contact drive arms to lower set of holes in wheel module and relocate down pressure springs to lower mounting rod on wheel module.

If planter center is higher or lower than wings after rephasing, contact your Kinze Dealer for valve adjustment or maintenance.

HYDRAULIC SEED RATE DRIVE

Refer to Kinze ISOBUS Operator's Manual (M0246) for information on setting and controlling hydraulic seed rate system.

**HALL EFFECT SENSOR
(HYDRAULIC DRIVE ONLY)**

Set hall effect sensor within 1/8" of pick-up disc.

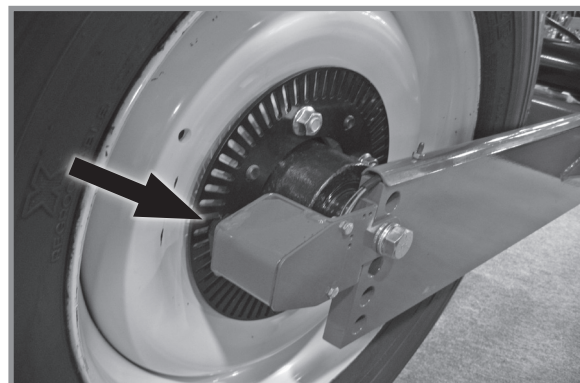

Hall effect sensor

JUMP START SENSOR

The jump start sensor is intended to reduce the seed gap when starting from a stop with the planter in the ground. For the jump start sensor to work as intended, the planter speed sensor needs to be set within $\frac{1}{8}$ " of the pick-up disc. The planter speed sensor also needs to be calibrated properly and have the speed source set to automatic. Refer to Kinze ISOBUS Operator's Manual (M0246) for calibration instructions.

If the planter speed sensor is set-up properly, the start-up gap should be no more than 4 feet. (1.2M)

If no gap is desired, there are two options for eliminating the gap completely:

1. Use the jump start button available on the ISOBUS display. Pressing this button will start turning the drives. Once a speed source is acquired, it will take over control. Refer to the ISOBUS manual for further instructions on the jump start button.
2. Pick the planter up, back up 10 - 12 feet (3 - 3.6M), set the planter down and resume planting. The section control will turn the drives on at the correct time.

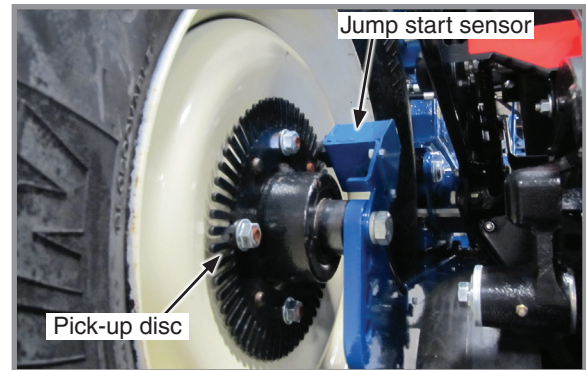

Jump Start Sensor and Pick-up Disc

FIELD OPERATION

Planters are designed to operate within a speed range of 2 - 8 mph (3 - 13 kph). Higher ground speeds can cause more variation in seed spacing. Speeds above 6.5 mph (10.5 kph) are typically not recommended.

NOTICE

Always raise planter out of ground when making sharp turns or backing up.

Normal field planting operation requires use of tractor's hydraulic control to raise and lower planter frame when making field turnarounds.

NOTICE

Operate row markers in float position to prevent damage to row markers.

Operate row markers with ISOBUS control or tractor's hydraulic control. After markers are lowered to ground, move hydraulic control to operate markers in float position. Marker speed is controlled with flow control valves located in planter left hand wing block. One valve controls raise speed and other valve controls lower speed of both markers. See ["Row Marker Speed Adjustment" on page 2-57](#) and ["Row Marker Cable Adjustment" on page 2-58](#).

TRANSPORT TO FIELD SEQUENCE USING ISOBUS

(If applicable, refer to [“Transport to Field Sequence Using Control Box” on page 2-33](#) or [“Transport to Field Sequence Using Advanced ISOBUS Control Box” on page 2-38](#))

Position planter in a relatively flat open area without furrows, etc.

**SUMMARIZED TRANSPORT TO FIELD SEQUENCE
USING ISOBUS VIRTUAL TERMINAL****NOTICE**

Tractor must be in neutral and allowed to roll freely when unfolding to prevent equipment damage, especially in soft conditions or when loaded with seed or fertilizer. Use tractor assist as needed to aid in unfolding and to reduce stress on frame and transport components.

1. Remove lockups.
2. If equipped with drawbar hitch, raise hitch slightly and remove hitch locking pin.
3. Move transport axle into field turnaround position.
4. Lower wing wheels into field turnaround position.
5. Lower hitch to sufficiently clear transport wing blocks.
6. Fold wings outward until stub wing latch pins are seated into H-frame receivers.
7. Lower planter and hold hydraulic lever for an additional 30 seconds to rephase lift cylinders.
8. If equipped with row markers, remove lockups and place in storage position.
9. Lower hitch to level machine during planting.

NOTE: Read following information for detailed instructions.

NOTICE

DO NOT fold or unfold planter without planter attached to a tractor. **DO NOT** unhitch planter from tractor unless fully folded for transport or fully unfolded with planting units lowered to ground.

1. Remove and store locking pin on drawbar hitch.
Remove lockups.

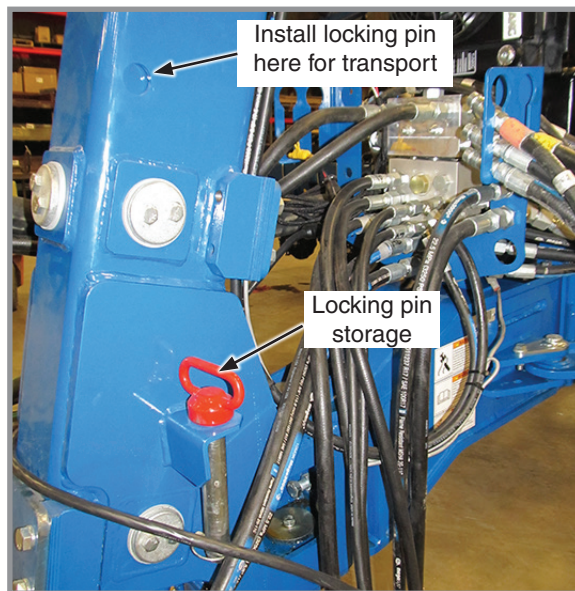

Locking Pin for Drawbar Hitch

- 2. Operate the proper hydraulic tractor control and press and hold the WING WHEEL LOWER button on your ISOBUS monitor to lower wing wheels into field turnaround position.
- 3. Operate the proper hydraulic tractor control and press and hold the ROTATE AXLE button on your ISOBUS monitor to lower transport axle to field turnaround position. If equipped with flip axle, move tires to field turnaround position as shown below.



ISOBUS Monitor Unfold Screen



Wing Wheels in Field Turnaround Position



Flip Axle in Field Turnaround Position

4. For planters equipped with drawbar hitch, operate proper hydraulic tractor control and press and hold the LOWER HITCH button on your ISOBUS monitor to unhook wings.

For planters equipped with 2-point hitch, operate proper hydraulic tractor control to lower drawbar to unhook wings.



ISOBUS Monitor Unfold Screen

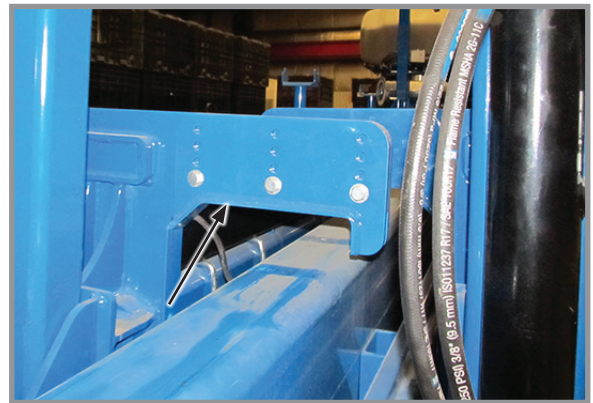

Hitch Release from Wing Hook

NOTICE

Unfolding planter without using tractor to assist may cause equipment damage especially in soft conditions or when loaded with seed or fertilizer. Use tractor to reduce stress on frame, drive, and transport components.

- Operate the proper hydraulic tractor control and press and hold the UNFOLD button on your ISOBUS monitor to move wings out, away from tractor. Planter is completely unfolded when stub wings are latched into the H-frame as shown in bottom photos.



Planter Unfolding

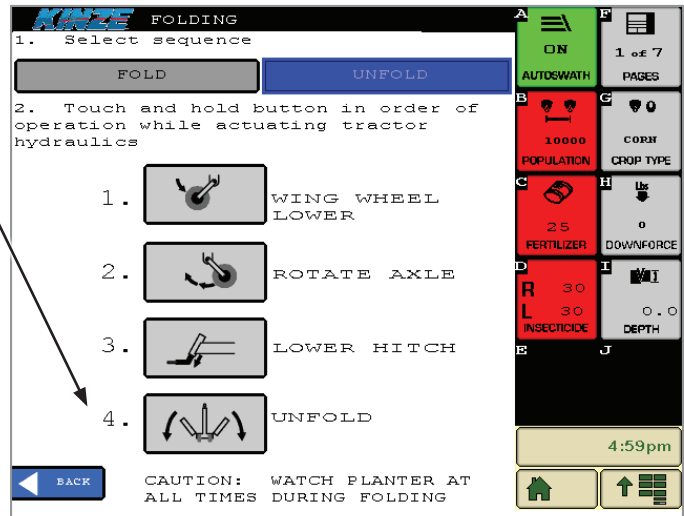

ISOBUS Monitor Unfold Screen



Stub Wing Latched into Frame

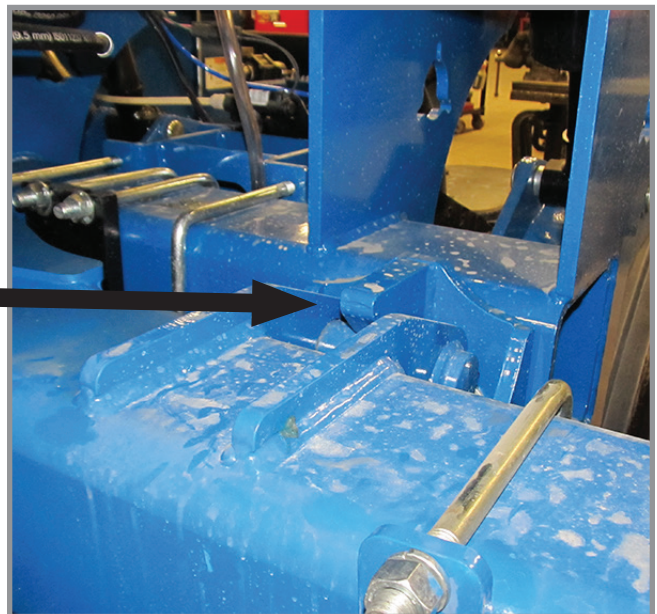

- Lower drawbar or 2-point hitch to level machine during planting.
- Lower planter and hold hydraulic lever for an additional 10-15 seconds to rephase cylinders.



TRANSPORT TO FIELD SEQUENCE USING CONTROL BOX

(If applicable, refer to [“Transport to Field Sequence Using Advanced ISOBUS Control Box”](#) on page 2-38)

Position planter in a relatively flat open area without furrows, etc.

**SUMMARIZED TRANSPORT TO FIELD SEQUENCE
USING CONTROL BOX****NOTICE**

Tractor must be in neutral and allowed to roll freely when unfolding to prevent equipment damage, especially in soft conditions or when loaded with seed or fertilizer. Use tractor assist as needed to aid in unfolding and to reduce stress on frame and transport components.

The control box and VT (virtual terminal) should not be used at the same time. Make sure markers are disabled on the VT when the control box is used to fold/unfold the planter.

1. Remove lockups.
2. Place function switch on control box in FOLD position.
3. If equipped with drawbar hitch, raise hitch slightly and remove hitch locking pin.
4. Move transport axle into field turnaround position.
5. Lower wing wheels into field turnaround position.
6. Lower hitch to sufficiently clear transport wing hooks.
7. Fold wings outward until stub wing latch pins are sealed into H-frame receivers.
8. Lower planter and hold hydraulic lever for an additional 30 seconds to rephase lift cylinders.
9. If equipped with row markers, remove lockups and place in storage position.
10. Lower hitch to level machine during planting.

NOTE: Read following information for detailed instructions.

NOTICE

DO NOT fold or unfold planter without planter attached to a tractor. **DO NOT** unhitch planter from tractor unless fully folded for transport or fully unfolded with planting units lowered to ground.

1. Remove and store locking pin on drawbar hitch. Remove lockups.

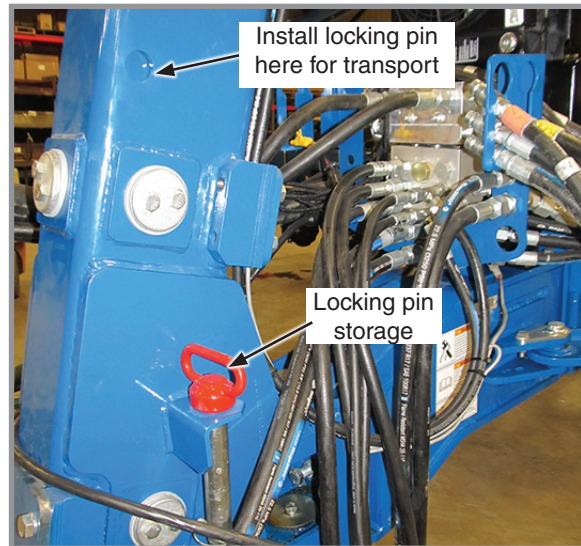

Locking Pin for Drawbar Hitch

2. Place FUNCTION switch on control box in fold position.
3. Operate the proper hydraulic tractor control and press and hold the WING WHEEL switch down to lower wing wheels into field turnaround position.
4. Operate the proper hydraulic tractor control and press and hold the AXLE switch up to lower transport axle to field turnaround position. If equipped with flip axle, move tires to field turnaround position as shown below.

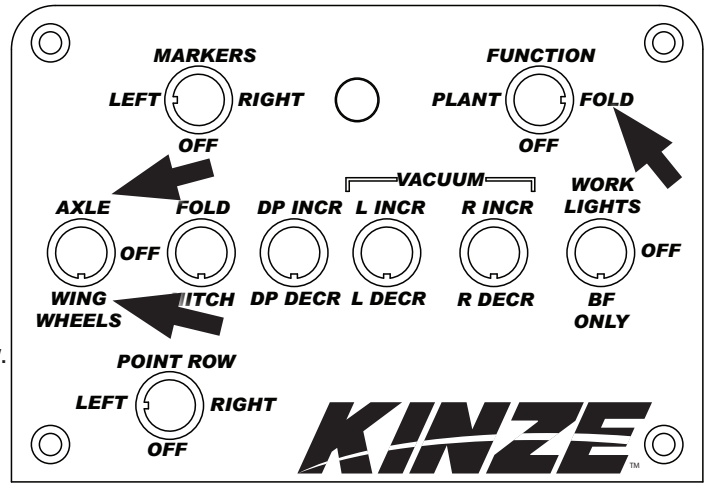

Control Box



Wing Wheels in Field Turnaround Position



Flip Axle in Field Turnaround Position

- 5. For planters equipped with drawbar hitch, operate proper hydraulic tractor control and press and hold the HITCH button down to raise drawbar to unhook wings.

For planters equipped with 2-point hitch, operate proper hydraulic tractor control to lower drawbar to unhook wings.

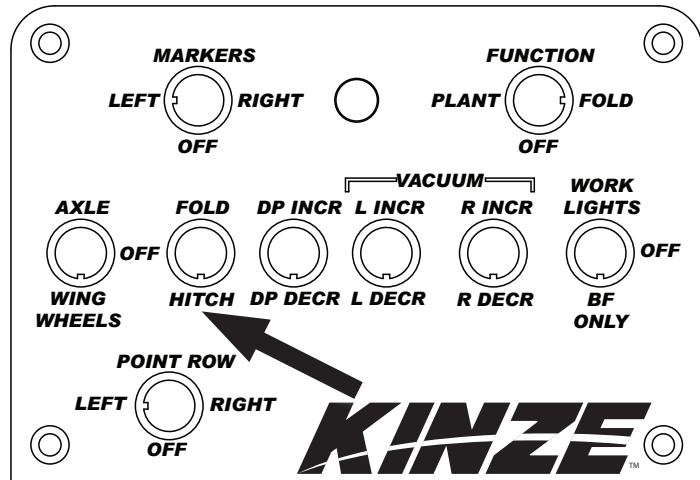

Control Box

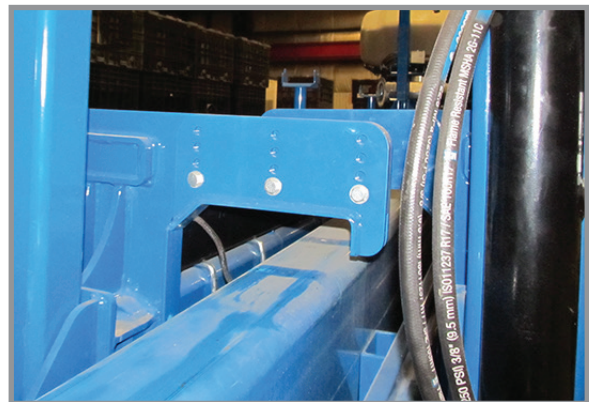

Hitch Release from Wing Hook

NOTICE

Unfolding planter without using tractor to assist may cause equipment damage especially in soft conditions or when loaded with seed or fertilizer. Use tractor to reduce stress on frame, drive, and transport components.

- Operate the proper hydraulic tractor control and press the FOLD switch up to move wings out, away from tractor. Planter is completely unfolded when stub wings are latched into the H-frame as shown in bottom photos.



Planter Unfolding

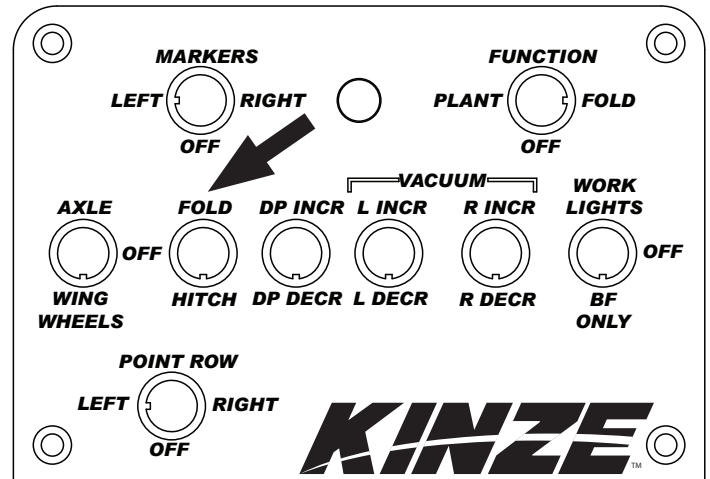

Control Box



Stub Wing Latched into Frame

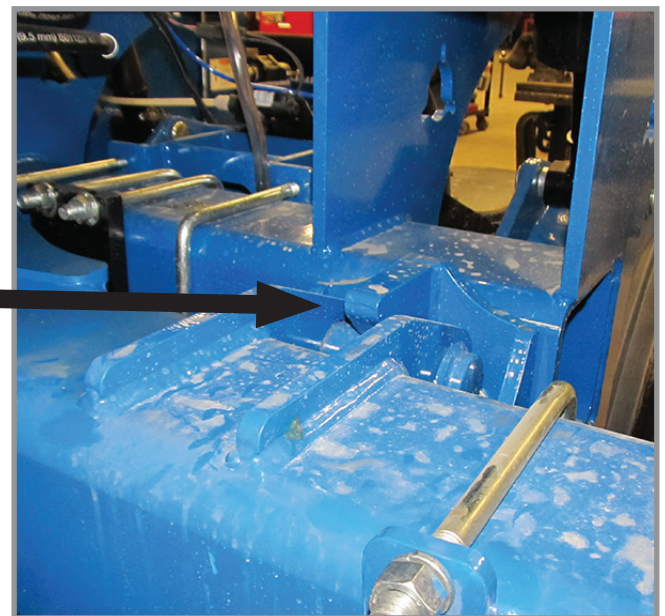

- Lower drawbar or 2-point hitch to level machine during planting.
- Lower planter and hold hydraulic lever for an additional 10-15 seconds to rephase cylinders.



TRANSPORT TO FIELD SEQUENCE USING ADVANCED ISOBUS CONTROL BOX

Position planter in a relatively flat open area without furrows, etc.

SUMMARIZED TRANSPORT TO FIELD SEQUENCE USING CONTROL BOX

NOTICE

Tractor must be in neutral and allowed to roll freely when unfolding to prevent equipment damage, especially in soft conditions or when loaded with seed or fertilizer. Use tractor assist as needed to aid in unfolding and to reduce stress on frame and transport components.

The control box and VT (virtual terminal) should not be used at the same time. Make sure markers are disabled on the VT when the control box is used to fold/unfold the planter.

1. Remove lockups.
2. Place function switch on control box in FOLD position.
3. If equipped with drawbar hitch, raise hitch slightly and remove hitch locking pin.
4. Move transport axle into field turnaround position.
5. Lower wing wheels into field turnaround position.
6. Lower hitch to sufficiently clear transport wing hooks.
7. Fold wings outward until stub wing latch pins are sealed into H-frame receivers.
8. Lower planter and hold hydraulic lever for an additional 30 seconds to rephase lift cylinders.
9. If equipped with row markers, remove lockups and place in storage position.
10. Lower hitch to level machine during planting.

NOTE: Read following information for detailed instructions.

NOTICE

DO NOT fold or unfold planter without planter attached to a tractor. **DO NOT** unhitch planter from tractor unless fully folded for transport or fully unfolded with planting units lowered to ground.

1. Remove and store locking pin on drawbar hitch.
Remove lockups.

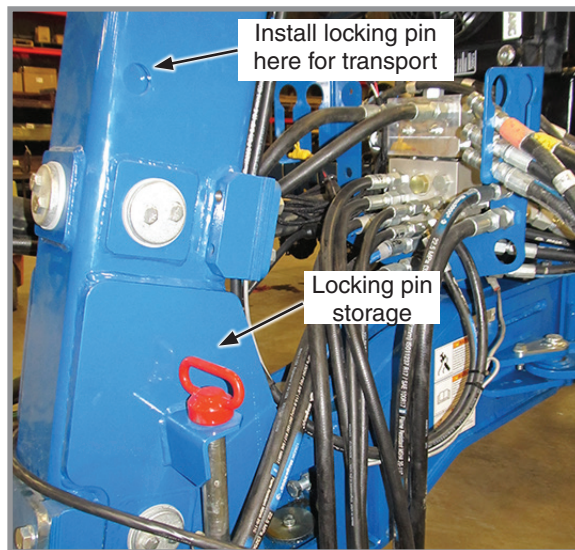

Locking Pin for Drawbar Hitch

2. Place FUNCTION switch on control box in fold position.
3. Operate the proper hydraulic tractor control and press and hold the WING WHEEL switch down to lower wing wheels into field turnaround position.
4. Operate the proper hydraulic tractor control and press and hold the AXLE switch up to lower transport axle to field turnaround position. If equipped with flip axle, move tires to field turnaround position as shown below.

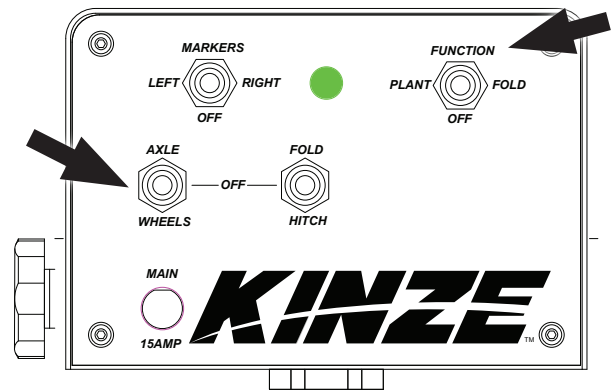

Control Box



Wing Wheels in Field Turnaround Position



Flip Axle in Field Turnaround Position

5. For planters equipped with drawbar hitch, operate proper hydraulic tractor control and press and hold the HITCH button down to raise drawbar to unhook wings.

For planters equipped with 2-point hitch, operate proper hydraulic tractor control to lower drawbar to unhook wings.

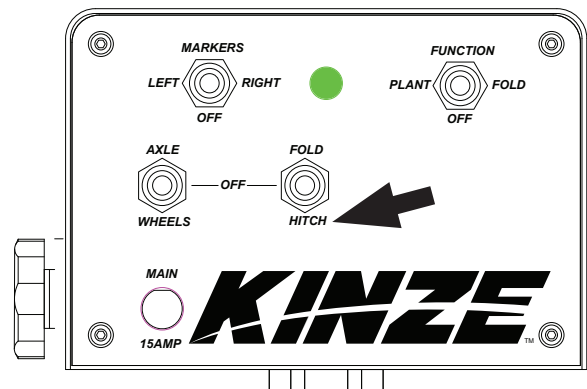

Control Box

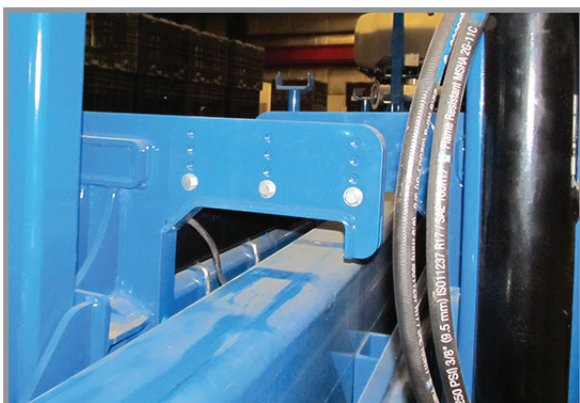

Hitch Release from Wing Hook

NOTICE

Unfolding planter without using tractor to assist may cause equipment damage especially in soft conditions or when loaded with seed or fertilizer. Use tractor to reduce stress on frame, drive, and transport components.

- Operate the proper hydraulic tractor control and press the FOLD switch up to move wings out, away from tractor. Planter is completely unfolded when stub wings are latched into the H-frame as shown in bottom photos.



Planter Unfolding

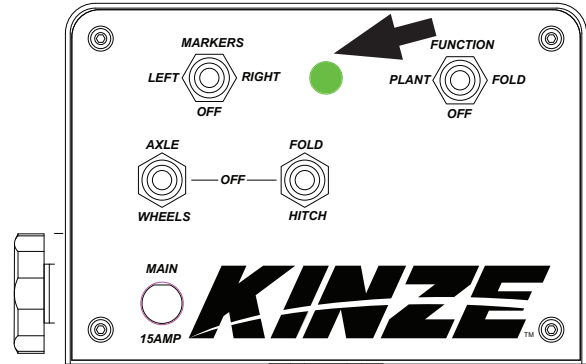

Control Box



Stub Wing Latched into Frame

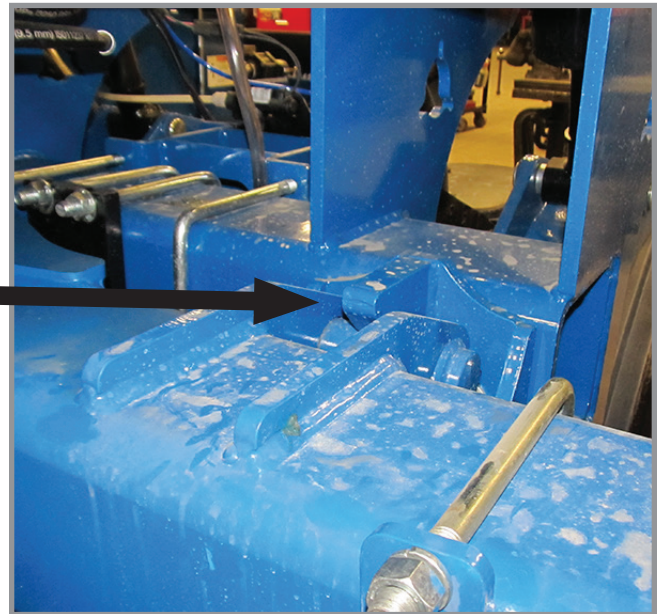

- Lower drawbar or 2-point hitch to level machine during planting.
- Lower planter and hold hydraulic lever for an additional 10-15 seconds to rephase cylinders.



FIELD TO TRANSPORT SEQUENCE USING ISOBUS

(If applicable, refer to [“Field to Transport Sequence Using Control Box” on page 2-47](#) or [“Field to Transport Sequence Using Advanced ISOBUS Control Box” on page 2-51](#))

Position planter in a relatively flat open area without furrows, etc.

**SUMMARIZED FIELD TO TRANSPORT SEQUENCE
USING ISOBUS VIRTUAL TERMINAL****NOTICE**

Tractor must be in neutral and allowed to roll freely when folding to prevent equipment damage, especially in soft conditions or when loaded with seed or fertilizer. Use tractor assist as needed to aid in unfolding and to reduce stress on frame and transport components.

1. If equipped with row markers, remove lockups from storage and install on marker cylinder rods.
2. Place planter into field turnaround position.
3. Lift drawbar or 2-point hitch to level planter frame.
4. Fold wings in toward tractor. As wing hooks approach the hitch tube, adjust hitch height to allow hooks to pass above it. The planter is fully folded when wing hooks are beyond hitch tube.
5. Lift hitch to lock wings into place after folding.
6. Raise transport axle to transport height or, if equipped with flip axle, roll tires fully into forward transport position.
7. Raise wing wheels into transport position.
8. If equipped with drawbar hitch, raise hitch slightly above transport position, install hitch locking pin, and lower hitch onto pin.
9. Install lockups.

NOTE: Read following information for detailed instructions.

NOTICE DO NOT fold or unfold planter without planter attached to a tractor. DO NOT unhitch planter from tractor unless fully folded for transport or fully unfolded with planting units lowered to ground.

1. If equipped with row markers, remove lockups from storage and install on marker cylinder rods.



Row Marker Safety Lockup Installed

2. Operate proper hydraulic tractor control to raise planter into field turnaround position.



3. For planters equipped with drawbar hitch, operate proper hydraulic tractor control and press and hold the RAISE HITCH button on your ISOBUS monitor to raise drawbar to level planter frame.

For planters equipped with 2-point hitch, operate proper hydraulic tractor control to raise drawbar to level planter frame.

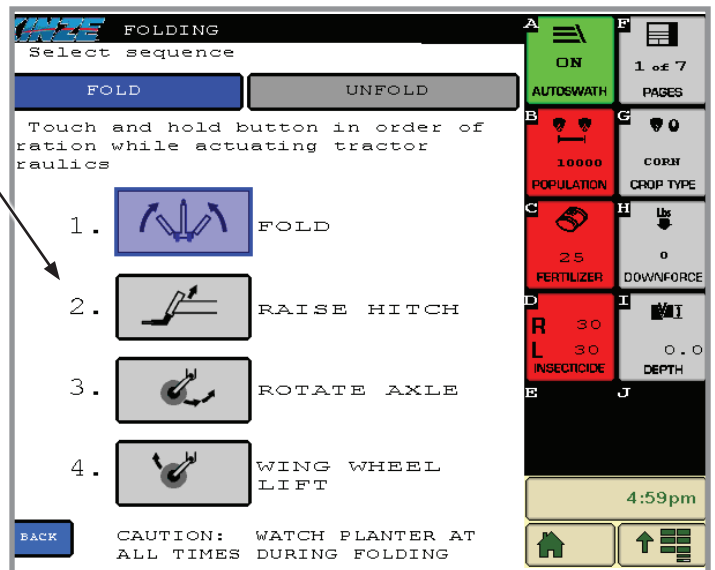

ISOBUS Monitor Fold Screen

NOTICE

Folding planter without using tractor to assist may cause equipment damage especially in soft conditions or when loaded with seed or fertilizer. Use tractor to reduce stress on frame, drive, and transport components.

- 4. Operate the proper hydraulic tractor control and press and hold the FOLD button on your ISOBUS monitor until 2 hooks are over the top of the inner hitch.
- 5. Lift drawbar or 2-point hitch to lock wings into place after folding.

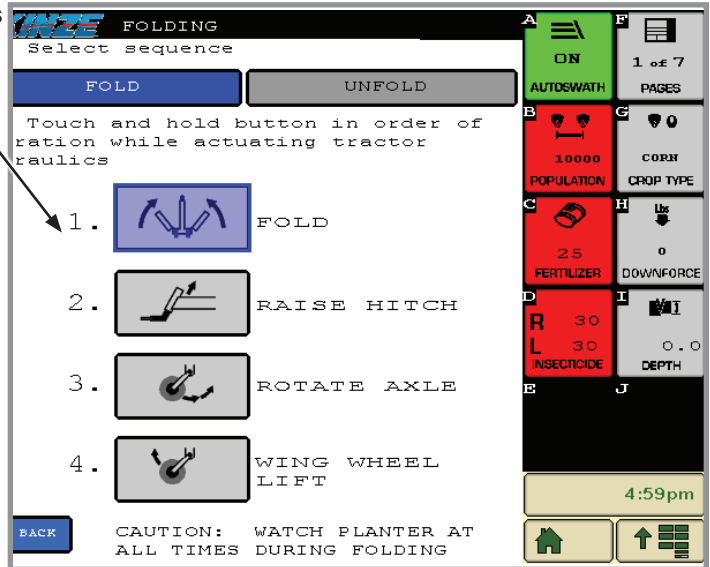

Planter Folding

ISOBUS Monitor Fold Screen

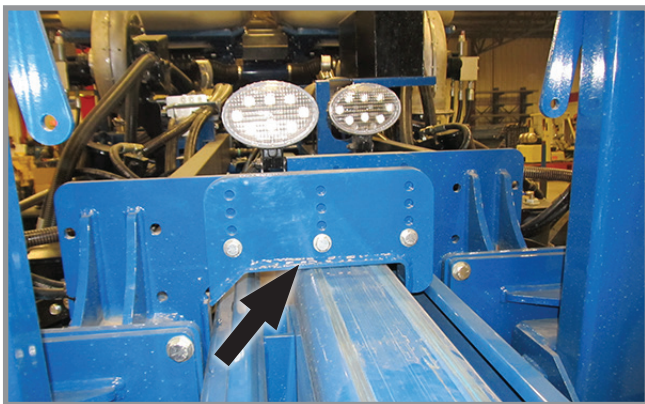

Wing Hook Locked

6. Operate the proper hydraulic tractor control and press and hold the ROTATE AXLE button on your ISOBUS monitor to raise transport axle to either transport height, or if equipped with flip axle, to the rest position as shown below.

7. Operate the proper hydraulic tractor control and press and hold the WING WHEEL LIFT button on your ISOBUS monitor to raise wing wheels into transport position.

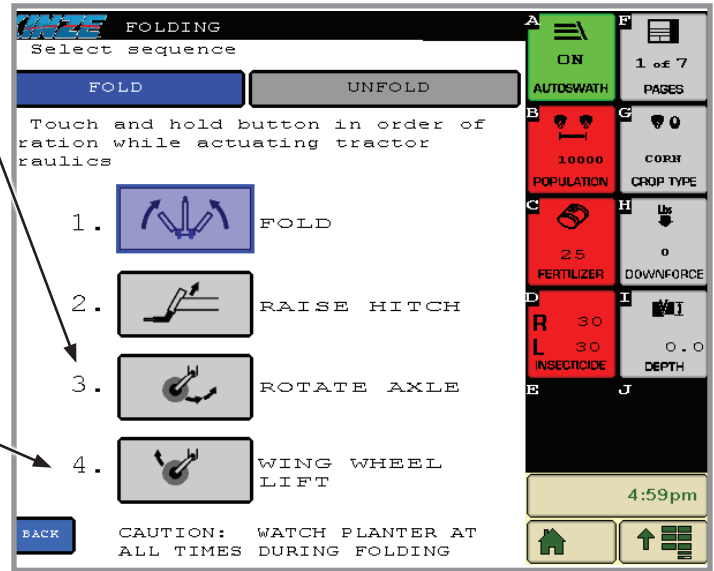

ISOBUS Monitor Fold Screen



Wing Wheels in Transport Position



Flip Axle in Rest Position

8. Install locking pin on drawbar.
9. Install lockups.

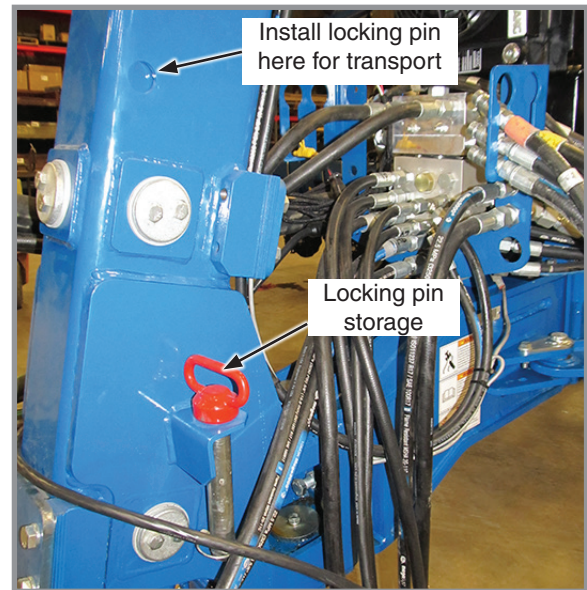

Locking Pin for Drawbar Hitch

FIELD TO TRANSPORT SEQUENCE USING CONTROL BOX

(If applicable, refer to [“Field to Transport Sequence Using Advanced ISOBUS Control Box”](#) on page 2-51)

Position planter in a relatively flat open area without furrows, etc.

**SUMMARIZED FIELD TO TRANSPORT SEQUENCE
USING CONTROL BOX****NOTICE**

Tractor must be in neutral and allowed to roll freely when folding to prevent equipment damage, especially in soft conditions or when loaded with seed or fertilizer. Use tractor assist as needed to aid in unfolding and to reduce stress on frame and transport components.

The control box and VT (virtual terminal) should not be used at the same time. Make sure markers are disabled on the VT when the control box is being used to fold/unfold the planter.

1. If equipped with row markers, remove lockups from storage and install on marker cylinder rods.
2. Place function switch on control box in FOLD position.
3. Place planter into field turnaround position.
4. Lift drawbar or 2-point hitch to level planter frame.
5. Fold wings in toward tractor. As wing hooks approach the hitch tube, adjust hitch height to allow hooks to pass above it. The planter is fully folded when wing hooks are beyond hitch tube.
6. Lift hitch to lock wings into place after folding.
7. Raise transport axle to transport height or, if equipped with flip-axle, roll tires fully into forward transport position.
8. Raise wing wheels into transport position.
9. If equipped with drawbar hitch, raise hitch slightly above transport position, install hitch locking pin, and lower hitch onto pin.
10. Install lockups.

NOTE: Read following information for detailed instructions.

NOTICE

DO NOT fold or unfold planter without planter attached to a tractor. **DO NOT** unhitch planter from tractor unless fully folded for transport or fully unfolded with planting units lowered to ground.

1. If equipped with row markers, remove lockups from storage and install on marker cylinder rods.



Row Marker Safety Lockup Installed

2. Operate proper hydraulic tractor control to raise planter into field turnaround position.



3. Place FUNCTION switch on control box in fold position.
4. For planters equipped with drawbar hitch, operate proper hydraulic tractor control and press the HITCH switch down to raise drawbar to level planter frame.

For planters equipped with 2-point hitch, operate proper hydraulic tractor control to raise drawbar to level planter frame.

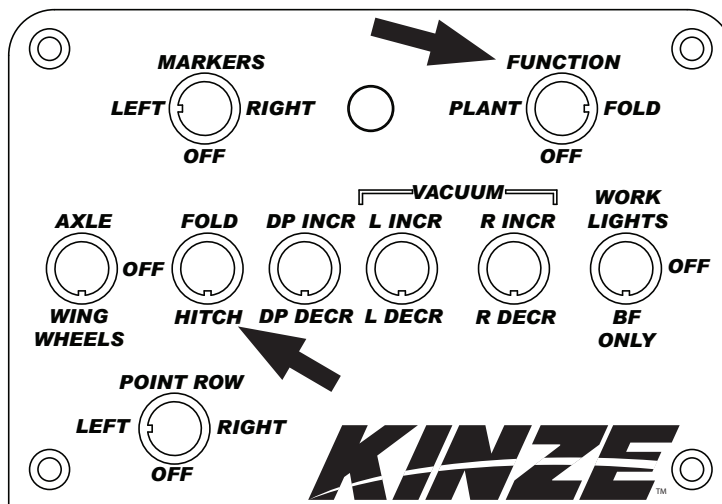

Control Box

NOTICE

Unfolding planter without using tractor to assist may cause equipment damage especially in soft conditions or when loaded with seed or fertilizer. Use tractor to reduce stress on frame, drive, and transport components.

- 5. Operate the proper hydraulic tractor control and press the FOLD switch up until 2 hooks are over the top of the inner hitch.
- 6. Lift drawbar or 2-point hitch to lock wings into place after folding.



Planter Folding

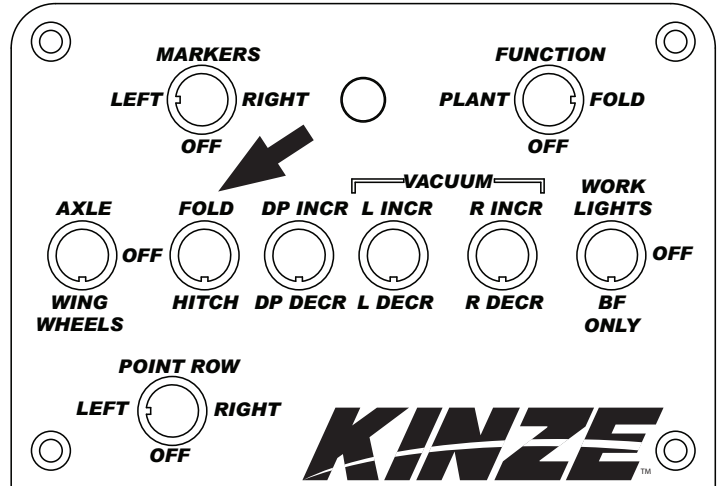

Control Box



Wing Hook Locked

7. Operate the proper hydraulic tractor control and press the AXLE switch up to raise transport axle to either transport height, or if equipped with flip axle, to the rest position as shown below.
8. Operate the proper hydraulic tractor control and press the WING WHEELS switch down to raise wing wheels into transport position.

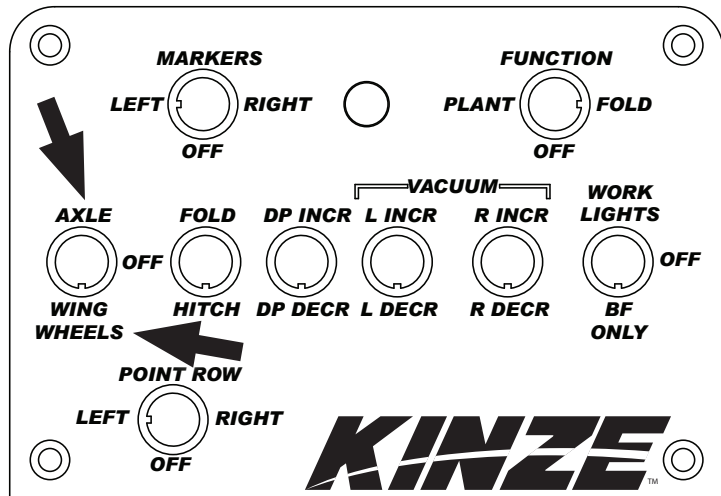

Control Box



Wing Wheels in Transport Position



Flip Axle in Rest Position

9. Install locking pin on drawbar.
10. Install lockups.

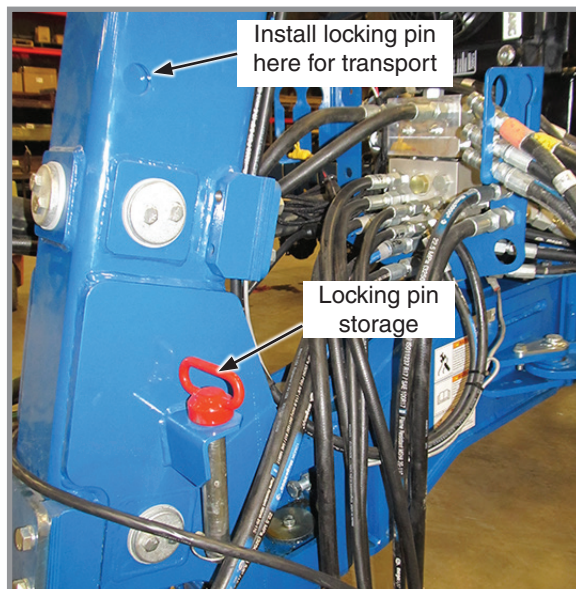

Locking Pin for Drawbar Hitch

FIELD TO TRANSPORT SEQUENCE USING ADVANCED ISOBUS CONTROL BOX

Position planter in a relatively flat open area without furrows, etc.

**SUMMARIZED FIELD TO TRANSPORT SEQUENCE
USING CONTROL BOX****NOTICE****NOTICE**

Tractor must be in neutral and allowed to roll freely when folding to prevent equipment damage, especially in soft conditions or when loaded with seed or fertilizer. Use tractor assist as needed to aid in unfolding and to reduce stress on frame and transport components.

The control box and VT (virtual terminal) should not be used at the same time. Make sure markers are disabled on the VT when the control box is being used to fold/unfold the planter.

1. If equipped with row markers, remove lockups from storage and install on marker cylinder rods.
2. Place function switch on control box in FOLD position.
3. Place planter into field turnaround position.
4. Lift drawbar or 2-point hitch to level planter frame.
5. Fold wings in toward tractor. As wing hooks approach the hitch tube, adjust hitch height to allow hooks to pass above it. The planter is fully folded when wing hooks are beyond hitch tube.
6. Lift hitch to lock wings into place after folding.
7. Raise transport axle to transport height or, if equipped with flip-axle, roll tires fully into forward transport position.
8. Raise wing wheels into transport position.
9. If equipped with drawbar hitch, raise hitch slightly above transport position, install hitch locking pin, and lower hitch onto pin.
10. Install lockups.

NOTE: Read following information for detailed instructions.

NOTICE	DO NOT fold or unfold planter without planter attached to a tractor. DO NOT unhitch planter from tractor unless fully folded for transport or fully unfolded with planting units lowered to ground.
---------------	--

1. If equipped with row markers, remove lockups from storage and install on marker cylinder rods.



Row Marker Safety Lockup Installed

2. Operate proper hydraulic tractor control to raise planter into field turnaround position.



3. Place FUNCTION switch on control box in fold position.
4. For planters equipped with drawbar hitch, operate proper hydraulic tractor control and press the HITCH switch down to raise drawbar to level planter frame.

For planters equipped with 2-point hitch, operate proper hydraulic tractor control to raise drawbar to level planter frame.

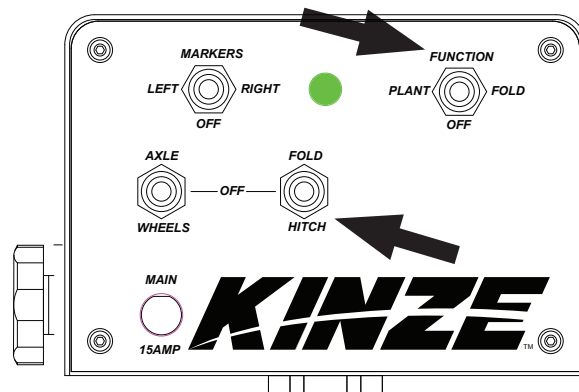

Control Box

NOTICE

Folding planter without using tractor to assist may cause equipment damage especially in soft conditions or when loaded with seed or fertilizer. Use tractor to reduce stress on frame, drive, and transport components.

- 5. Operate the proper hydraulic tractor control and press the FOLD switch up until 2 hooks are over the top of the inner hitch.
- 6. Lift drawbar or 2-point hitch to lock wings into place after folding.

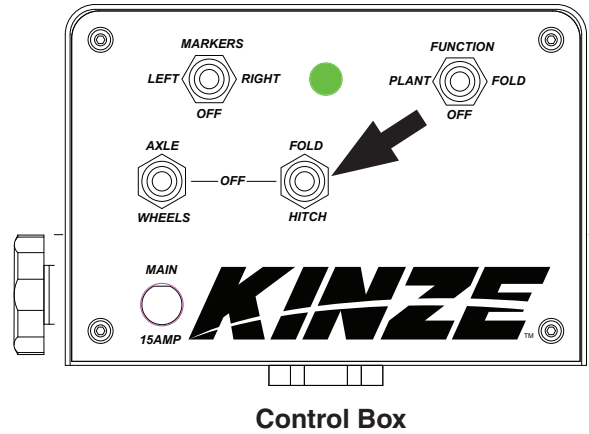

Planter Folding

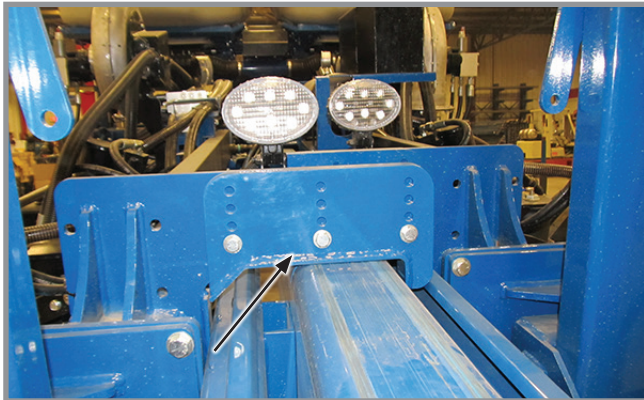

Wing Hook Locked

7. Operate the proper hydraulic tractor control and press the AXLE switch up to raise transport axle to either transport height, or if equipped with flip axle, to the rest position as shown below.
8. Operate the proper hydraulic tractor control and press the WING WHEELS switch down to raise wing wheels into transport position.

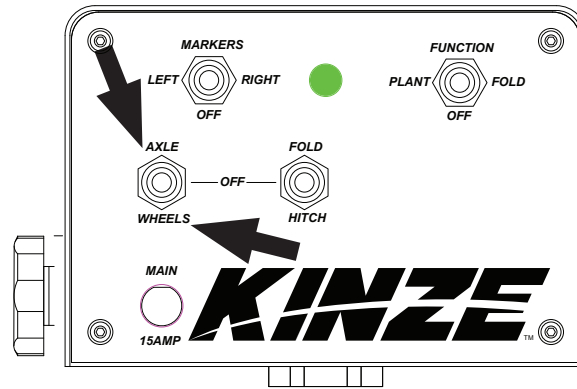

Control Box



Wing Wheels in Transport Position



Flip Axle in Rest Position

9. Install locking pin on drawbar.
10. Install lockups.

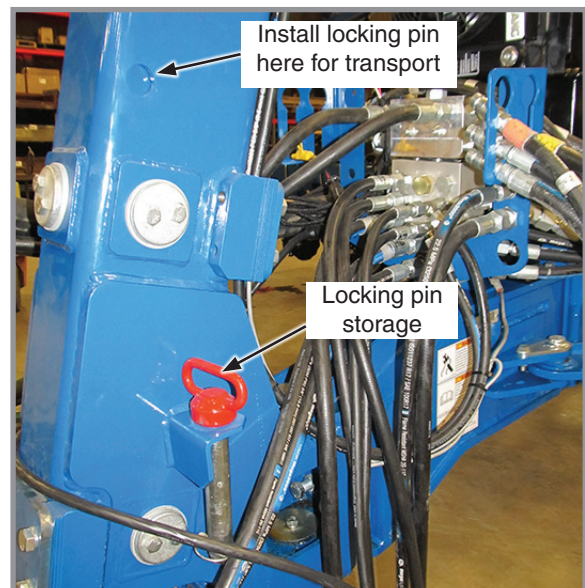

Locking Pin for Drawbar Hitch

ROW MARKER OPERATION USING ISOBUS

(Row marker operation using control box, proceed to next page)

DANGER

Contacting or coming close to power lines or other high energy sources will cause death or serious injury.

Keep away from power lines or high energy sources at all times.

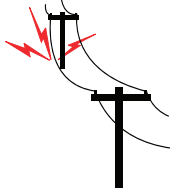

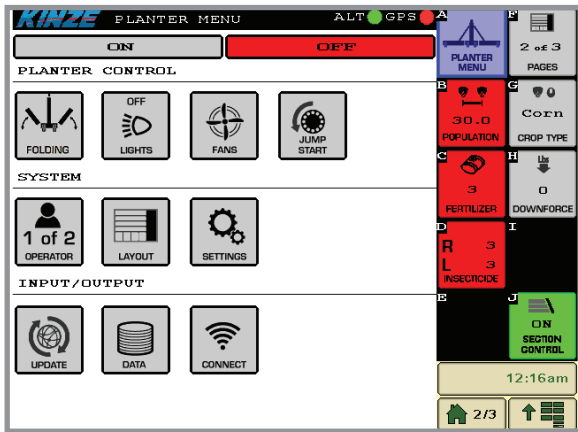

ISOBUS Screen

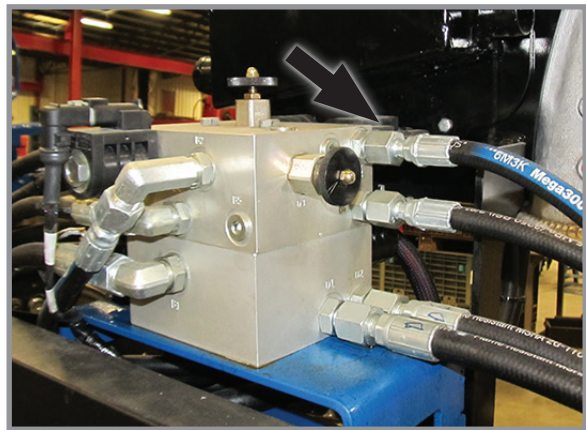

Row Marker Solenoid Valves

ROW MARKER OPERATION USING CONTROL BOX

DANGER

Contacting or coming close to power lines or other high energy sources will cause death or serious injury.

Keep away from power lines or high energy sources at all times.

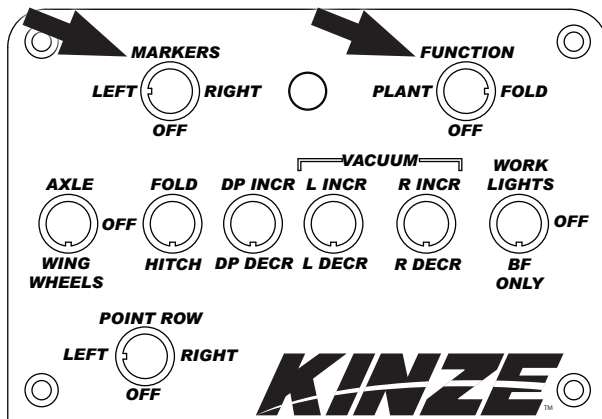

Control Box

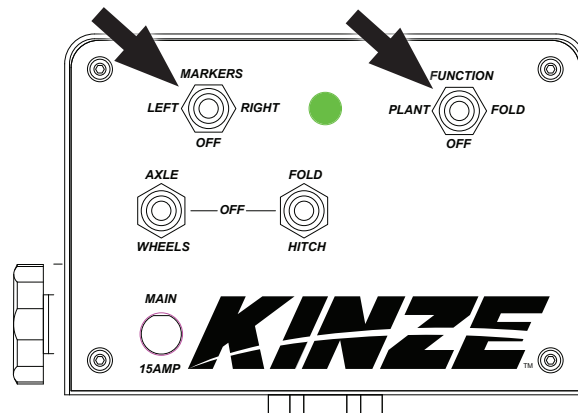

Control Box Option for Advanced ISOBUS

Two solenoid valves on valve block at rear L.H. side of center frame, and a three position selector switch on control console permit operator to lower or raise desired row marker.

NOTE: See row marker adjustments on following pages.

1. Place FUNCTION switch in PLANT position.
2. Place MARKERS switch in LEFT or RIGHT position.
3. Toggle switch to other side to operate opposite row marker.
4. Raise row marker at end of field.
5. After turn, lower the pre-selected row marker.
6. Continue to follow this procedure.

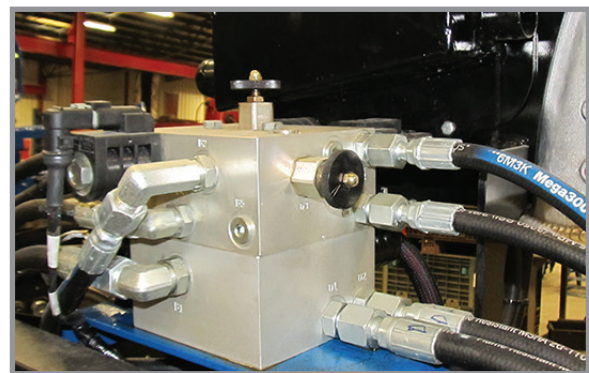

Row Marker Solenoid Valves

NOTE: Both row markers can be lowered by operating switch in each position and hydraulic control twice. Row markers raise simultaneously with hydraulic control in raise position.

If electrical system does not operate properly:

- Check fuse.
- Check wiring connections.
- Check control switch.
- Check solenoid. SOLENOID HOUSING IS MAGNETIZED WHEN ENERGIZED.

ROW MARKER SPEED ADJUSTMENT

NOTICE

Excessive row marker travel speed can damage row markers. Adjust flow controls before row markers are first used.

Marker hydraulic system includes two flow control valves. One flow control valve sets lowering speed and one sets raising speed of both markers. Flow controls determine amount of oil flow restriction through valves, varying marker travel speed.

Loosen jam nut and turn control clockwise, or IN to slow travel speed. Turn counterclockwise, or OUT to increase travel speed. Tighten jam nut after adjustments are complete.

NOTE: Tractors with flow control valves. Make row marker speed adjustment with tractor flow controls in maximum position. After row marker speed is set, adjust tractor flow controls to allow hydraulic control to stay in detent during marker raise or lower cycle.

NOTE: Hydraulics operate slowly when oil is cold. Make all adjustments with oil warm.

NOTE: On a tractor where oil flow cannot be controlled, tractor flow rate may be greater than rate marker cylinder can accept. Hold tractor hydraulic control lever until cylinder reaches end of its stroke. This occurs most often on tractors with an open center hydraulic system.

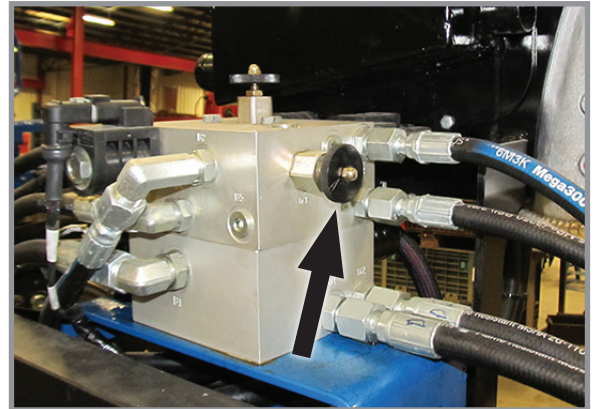

Row Marker Speed Control Adjustment

ROW MARKER CABLE ADJUSTMENT

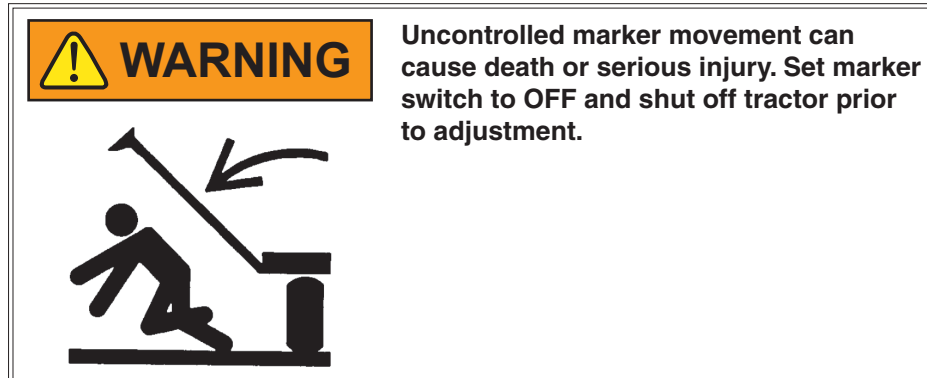

NOTE: Operate two-fold or three-fold row markers with the tractor's hydraulic valve in float position.

NOTE: A cable or chain may be used. For continuity, cable will be used in this manual.

Cable adjustment is critical. Adjust with second stage of marker in vertical position and first stage in horizontal position.

Cable must be adjusted so third stage of marker is pulled out as soon as second stage begins outward travel. Cable stretches with use and needs routine adjustment. It may be necessary to twist for a finer adjustment.

Marker cable is PROPERLY ADJUSTED if marker blade pushes dirt 12" (30.5 cm) or less as marker completes fold into field operating position. Cable should have some slack when marker is in field operating position.

Marker cable is TOO LOOSE and should be adjusted if marker blade pushes dirt more than 12" (30.5 cm) as it completes the fold into field operating position.

Marker cable is TOO TIGHT if it will not allow marker blade to follow ground contour and cable is tight when marker is in field operating position.

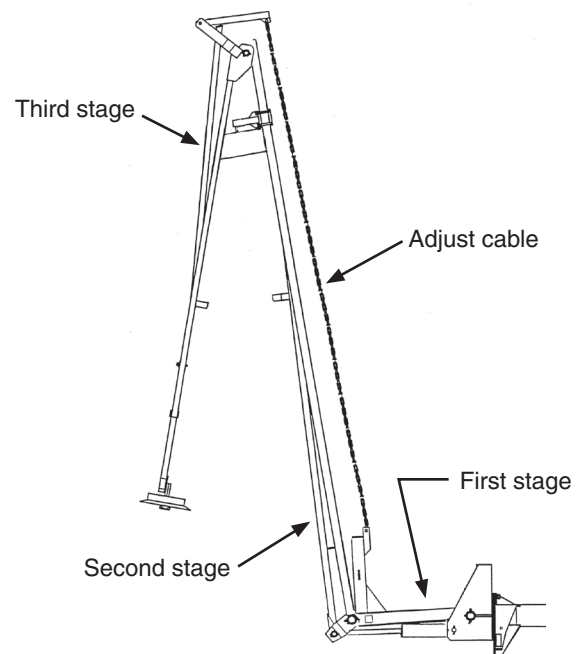

ROW MARKER LENGTH AND DISC BLADE ADJUSTMENT

1. Multiply number of rows by the average row spacing in inches to determine total planting width.

Row Marker Lengths	
12 Row 30"	360" (914.4 cm)
16 Row 30"	480" (1,219.2 cm)
24 Row 30"	720" (1,828.8 cm)

2. Lower planter and row marker assembly to ground.
3. Measure from planter center line to a point where blade contacts ground.
4. Adjust row marker extension so distance from marker disc blade to center line of planter is equal to total planting width. Adjust right and left row marker assemblies equally and securely tighten clamping bolts.

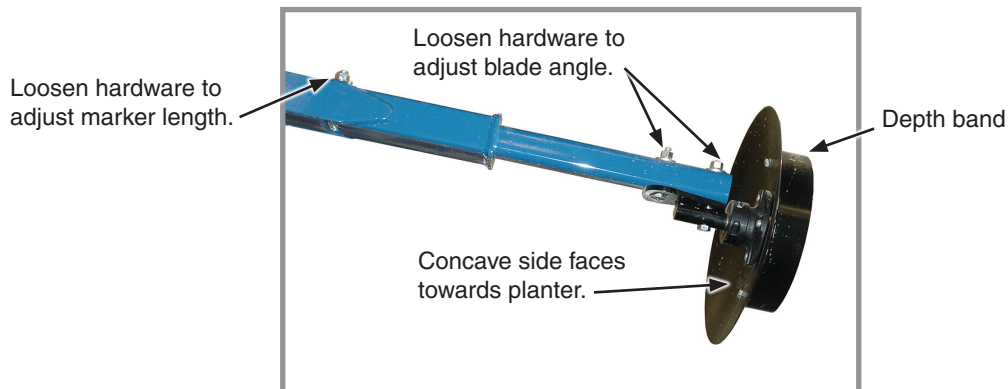

Row Marker Disc Blade Angle Adjustment

NOTICE

Setting marker disc blade assembly at a sharper angle than needed adds stress to row marker assembly and shortens bearing and blade life. Set blade angle only as needed to leave a clear mark.

Marker disc blade is installed with concave side facing inward. Spindle assembly is slotted so hub and blade can be angled to throw more or less dirt.

5. Loosen hardware and move assembly as required.
6. Tighten bolts to specified torque.
7. Do a field test to ensure markers are properly adjusted.

NOTE: A notched marker blade is available from Kinze through your Kinze Dealer for use in more severe no till conditions.

VACUUM METER SYSTEM

Kinze vacuum meter seed metering system includes seed meters, seed discs, and an air system consisting of a hydraulic driven vacuum fan which draws air through manifolds, hoses, and seed meters on each row unit.

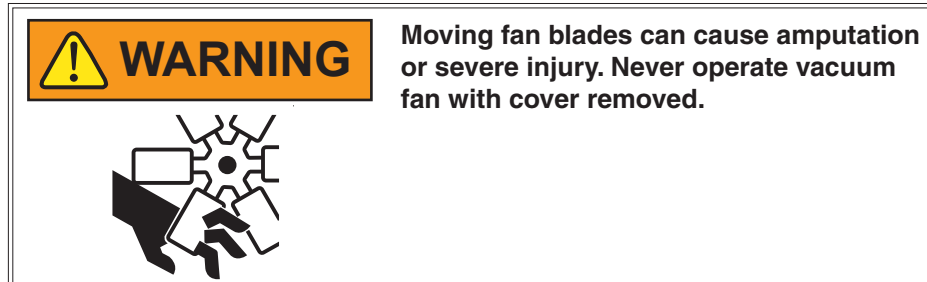

ANALOG VACUUM OR PRESSURE GAUGE

Analog vacuum or pressure gauge connects directly to vacuum meter (vacuum) or bulk fill (pressure) manifold and is teed into digital sending units.

Only adjustment is to “zero” needle with no vacuum or pressure present. If there is a significant difference between gauge and a reading taken at meters, a different manifold location should be found to connect hose to gauge and digital sending unit.

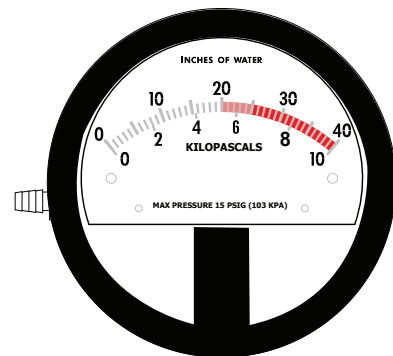

Analog Gauge

NOTE: Analog gauges are identical EXCEPT for plug and hose barb locations in side of gauge housing. DO NOT connect vacuum meter or bulk fill hose to wrong gauge. Check plug and hose barb installation if readout is erratic or appears inaccurate.

BULK FILL SYSTEM**WARNING**

Do not remove lid during machine operation. Contents are pressurized and could result in death, serious injuries or equipment damage.

Review operator manual for proper filling procedure.

**CAUTION**

Seed flying out of disconnected delivery tube at high velocity can cause injury. Do not disconnect delivery tubes when system is operating.

**DANGER**

DO NOT ENTER. Hazardous conditions inside will result in death or serious injury. Follow OSHA confined space procedures.

NOTICE

Foreign materials can plug system. Make sure seed is clean and free of debris when filling bulk fill hoppers.

NOTICE

Do not turn on system with tractor engine at full speed or system damage may occur.

NOTICE

Do not operate bulk fill system above maximum system operating pressure of 20 inches of water or seed bridging may occur.

1. **Before filling hoppers, refer to ““Row Unit Operation” on page 3-1 for additives information.** Fill hoppers with seed, then twist lid clockwise to close.
2. Start bulk fill delivery system with tractor engine at idle.
3. Increase engine speed to full and set initial system pressure using flow control valve.
4. Allow system to warm up and adjust pressure if necessary.

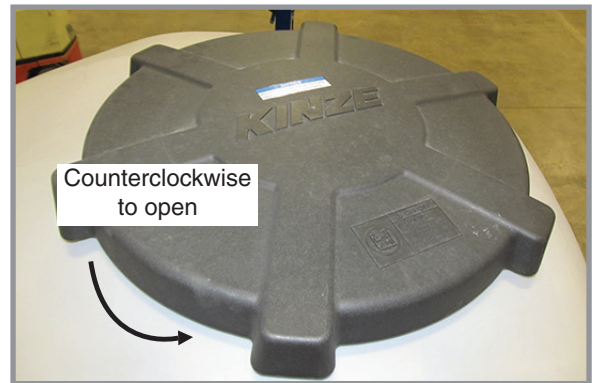

Bulk Fill Lid

Recommended pressures:

- Corn – 12 inches (30.5 cm) of water
- Soybeans – 10 inches (25.4 cm) of water
- Actual pressure needed is affected by seed size, shape, and coating.

BULK FILL ENTRAINER ACCESS

1. Shut down bulk fill system.
2. Loosen wing nut and turn retainer holding shutoff door in its storage location.
3. Remove rubber plug closest to area in entrainer needing attention.
4. Insert shutoff door into open slot and push into entrainer at a slight upward angle.
5. When work is complete, remove shutoff door, return door to storage location, and plug open slot.

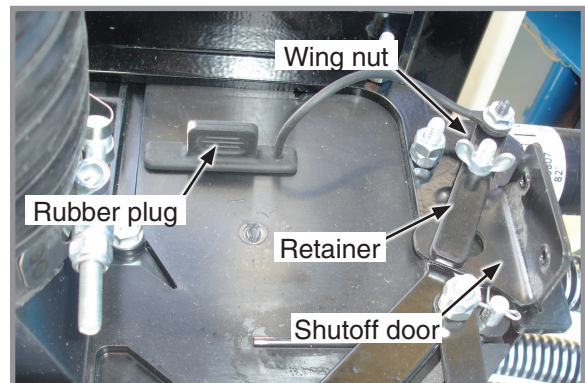

Bulk Fill Entrainer (End View)

BULK FILL TANKS - CLEAN OUT

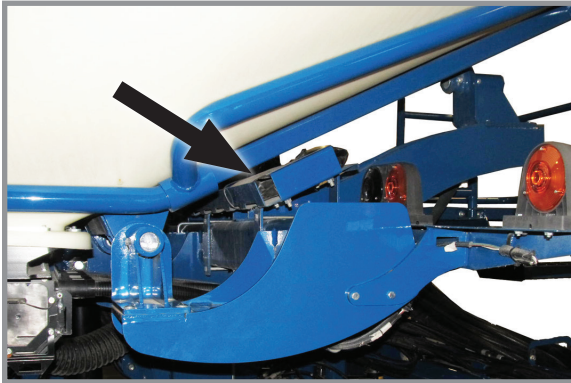

Cleanout Chute Storage Location

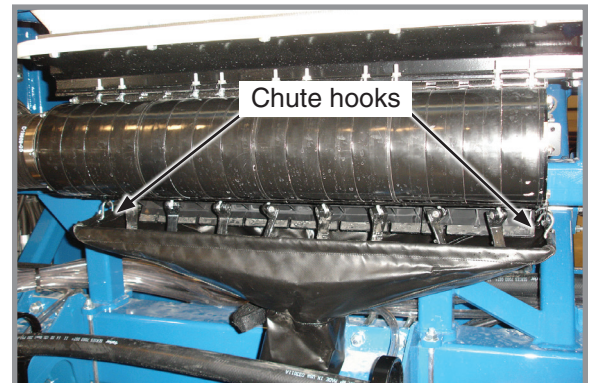

Cleanout Chute Installed

1. Remove bulk fill tank cleanout chute from storage location under L.H. bulk fill tank.
2. Position tube of chute under entrainer and attach hooks on each end of entrainment assembly.
3. Open cleanout doors and empty tank.
4. Close all cleanout doors and return cleanout chute to storage location.

BULK FILL SCALE PACKAGE OPTION

NOTICE

High-pressure water can damage display. Remove display before power washing planter.

NOTICE

Remove and store display at end of planting season. Damage from sun and weather exposure may result.

- Provides seed weight or estimated acres remaining for each bulk fill hopper.
- Displays total (gross) seed weight or estimated acres remaining for both hoppers combined.
- Warns operator when seed goes below a pre-defined level (ISO display).

Operation of Bulk Fill Scale Package display is controlled by buttons located on its face:

- Two screen-defined selection buttons.
- Backlight ON/OFF button.
- UP/DOWN arrow buttons.
- Screen position is changed by loosening thumb screw on mount at back of monitor and repositioning screen.

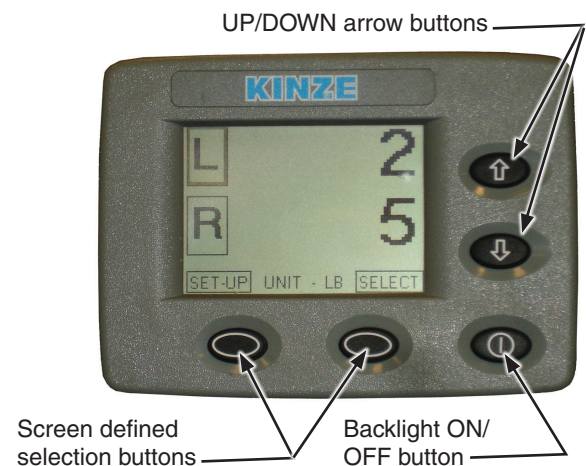

MONITOR SEED LEVELS

1. Main screen displays information for left and right hoppers.
2. Select L or R for individual hopper status information.
3. Select BACK to return to main screen.
4. Press down arrow once or twice for GROSS screen to appear.
This provides combined status information for both hoppers.
5. Press down arrow again to return to main screen.



AG LEADER INCOMMAND 1200 DISPLAY

The InCommand 1200 is a full-featured display for any precision farming operation. A large, full-color 12.1" HD touchscreen display is easy to read and offers powerful, year-round precision farming tools. Mapping, planter and application control, yield monitoring, real-time data logging, and more – are all controlled from the cab using the InCommand display.

Four video camera inputs provide operators a better view of equipment operation and safety by allowing them to view live video on the display.



Ag Leader InCommand Display

NOTE: See InCommand operator manual for installation and programming.

MASTER MODULE

The Master Module is found on the planter and relays information to and takes inputs from the Virtual Terminal (VT). It also executes the manual and automatic rate control, and swath control commands. These functions are available with the Kinze ISOBUS product control package.

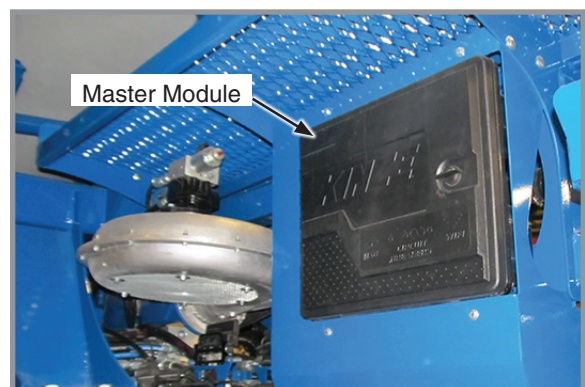

Planter Master Module (PMM)
(Bulk fill system shown)

POINT ROW CLUTCHES

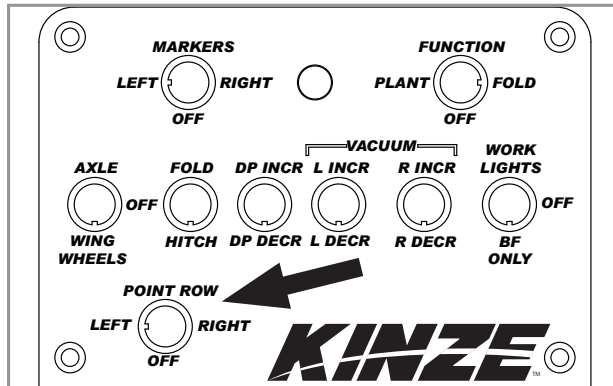

Control box

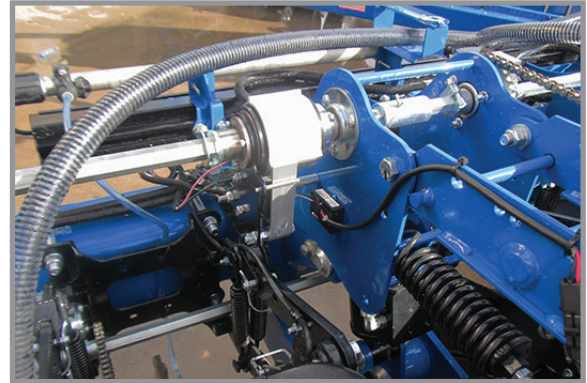

Point row clutch

Electric-activated clutches disengage drive on either half of planter for finishing up fields or for long point row situations. Clutch selector switch is located on tractor control box.

NOTE: Liquid fertilizer piston pump has its own drive wheel and is not affected by point row clutch.

NOTICE

Switch must be OFF when planter is not in use or tractor battery will be drained.

Clutch consists of a wrap spring riding on an input and output hub. Wrap spring is wrapped tightly over hubs during operation locking them together. Higher speeds create a tighter grip of spring on hubs.

Input end of spring is bent outward and is called the control tang. Control tang fits into a slot in stop collar located between input and output hubs over wrap spring. If stop collar is allowed to rotate with input hub, clutch is engaged. If stop collar is stopped from rotating, control tang connected to it is forced back and spring opens. This allows input hub to continue rotating without transmitting torque to output hub, stopping planter drive.

Stop collar is controlled by an electric solenoid and an actuator arm. When selector switch on tractor control box is OFF, solenoid coil is NOT ENERGIZED and actuator arm will not contact stop on stop collar, allowing it to rotate with hubs and drive planter.

When operational switch is in "DISENGAGE" (right or left) solenoid coil IS ENERGIZED and plunger in solenoid coil pulls actuator arm against stop on stop collar, disengaging wrap spring and stopping planter drive.

FIELD TEST

Perform a field test with any change of field and/or planting conditions, seed size or planter adjustment to ensure proper seed placement and operation of row units.

- Check planter for front to rear and lateral level operation. See [“Level Planter” on page 2-26](#).
- Check **all** row units to be certain they are running level. Row unit parallel arms should be approximately parallel to the ground when planting.
- Check row markers for proper operation and adjustment. See [“Row Marker Speed Adjustment” on page 2-57](#), [“Row Marker Cable Adjustment” on page 2-58](#), and [“Row Marker Length And Disc Blade Adjustment” on page 2-59](#).
- Check for proper application rates and placement of granular chemicals on **all** rows. See [“Field Check Granular Chemical Application” on page 2-68](#).
- Check for desired depth placement and seed population on **all** rows. See [“Field Check Seed Population” on page 2-66](#).
- Check for proper application rates of fertilizer on **all** rows. See [“Rate Charts” on page 5-1](#).

Reinspect machine after field testing.

- Hoses And Fittings
- Bolts And Nuts
- Cotter Pins And Spring Pins
- Drive Chain Alignment

FIELD CHECK SEED POPULATION

1. Tie up one or more sets of closing wheels by running a chain or rubber tarp strap between the hopper support panel and closing wheels. It may be necessary to decrease closing wheel arm spring tension.
2. Plant a short distance and check to see if seed is visible in the seed trench. Adjust planting depth to a shallower setting if seed is not visible and recheck.

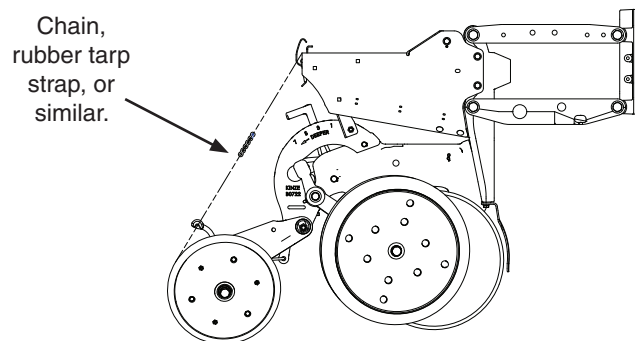

Planting depth adjustment handle

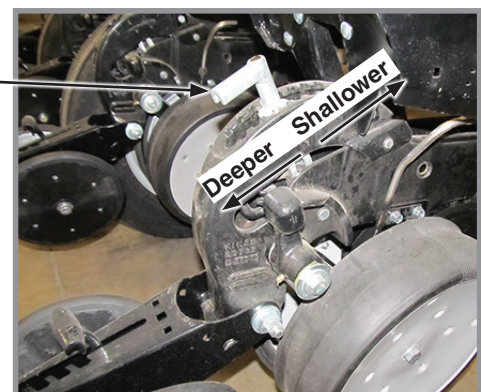

Planting Depth Adjustment

3. Measure $\frac{1}{1000}$ of an acre. See chart for correct distance for row width being planted. For example, planting 30" rows $\frac{1}{1000}$ of an acre is 17' 5".

$\frac{1}{1000}$ Acre Seed Population Count Row Width/ Distance		
Distance	26'2" (66.5 cm)	17'5" (44.4 cm)

NOTE: Seeds may bounce or roll when planting with closing wheels raised and planting depth set shallow affecting seed spacing accuracy.

4. Count seeds in measured distance.
5. Multiply number of seeds placed in $\frac{1}{1000}$ of an acre by 1000. This gives total population.

EXAMPLE: 30" row spacing 17' 5" equals $\frac{1}{1000}$ acre.
26 seeds counted x 1000 = 26,000 seeds per acre

Seed count can be affected by drive wheel and seed meter drive ratio, tire pressure, and/or seed meter malfunction.

1. If seed check shows average distance between seeds in inches is significantly different than seed rate chart indicates, first check drive ratio between drive wheel and seed meter. Check drive wheel air pressure, check for incorrect sprocket(s) in driveline and check drive and driven sprockets on transmission(s) for proper selection.
2. Check for seed meter malfunction. For example, if spacing between kernels of corn at the transmission setting being used is 8" and a gap of 16" is observed, a finger has lost its seed and not functioned properly. If two seeds are found within a short distance of each other, finger has metered two seeds instead of one.

DETERMINING POUNDS PER ACRE

Seeds per acre \div Seeds per pound (from label) = Pounds per acre

If seeds per pound information is not available use the following averages:

2,600 seeds per pound for medium size soybeans
15,000 seeds per pound for medium size milo/grain sorghum
4,500 seeds per pound for medium size cotton

DETERMINING BUSHELS PER ACRE

Pounds per acre \div Seed unit weight = Bushels per acre



Average Unit Weight of:

1 Bushel Soybeans = 60 Pounds (27.2 kg)
1 Bushel Milo/Grain Sorghum = 56 Pounds (25.4 kg)
1 Bushel Cotton = 32 Pounds (14.5 kg)

If seed population check shows planting rate is significantly different than seed rate chart shows or if a particular meter is not planting accurately, see ["Vacuum Seed Meter Maintenance" on page 6-18.](#)

FIELD CHECK GRANULAR CHEMICAL APPLICATION

Temperature, humidity, speed, ground conditions, flowability of different material, or meter obstructions can affect granular chemical rate of delivery.

 WARNING	<p>Agricultural chemicals can cause death or serious injury to persons, animals, and plants or seriously damage soil, equipment, or property. Read and follow all chemical and equipment manufacturers labels and instructions.</p>
	

Perform a field check to determine application rates.

1. Fill insecticide and/or herbicide hoppers.
2. Attach a calibrated vial to each granular chemical meter.
3. Lower planter and drive 1320 feet (402 M) at planting speed.
4. Weigh chemical in ounces caught in one vial.
5. For 30" row width, multiply that amount by 0.83 to determine pounds per acre.

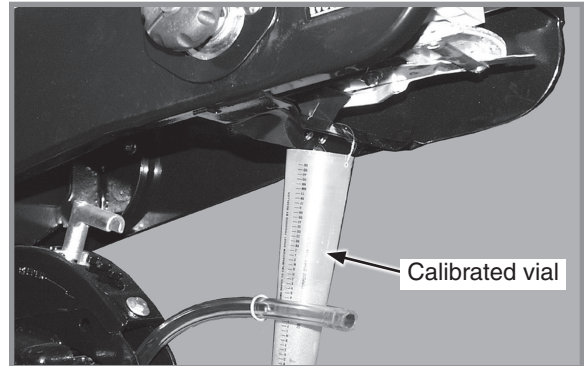

Granular Chemical Field Check

EXAMPLE: You have planted for 1320 feet (402 M) at desired planting speed. You caught 12.0 ounces of chemical in one vial. 12.0 ounces times 0.83 equals 9.96 pounds per acre.

NOTE: Check calibration of all rows.

WATER TANK

The water tank is to only be filled with clean water or preferably potable water (water meeting local standards for drinking). The tank holds 4 gallons (15 L) of water. Be sure to check for regulations pertaining to this use. Tank should be filled with new water at the beginning of each planting season and drained at the end of each planting season.

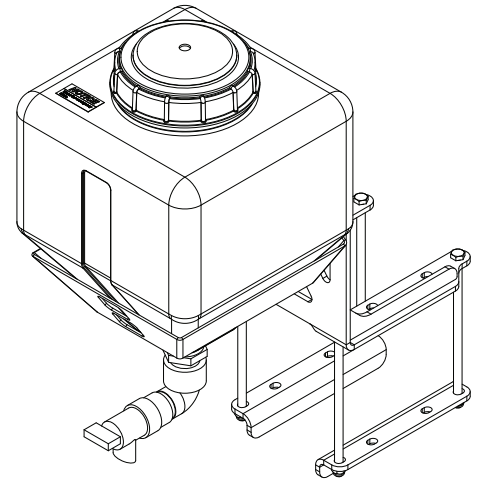

NOTICE

Drain tank if environmental conditions are 32° Fahrenheit (0° Celsius) or below to prevent tank from cracking.

The water tank is to be used in the event of an accidental exposure to chemical. Chemicals are supplied with Material Safety Data Sheets (MSDS) that provide full information about the chemical, its effects on exposure, and first aid needs in the event of an emergency. Keep your MSDS file up-to-date and available for first responders in case of emergency.

If the water tank is used seek medical assistance immediately for further treatment.

This page intentionally left blank.

PLANTING DEPTH

Planting depth is maintained by adjustable row unit gauge wheels. Depth adjustment range is approximately $\frac{1}{2}$ " to $\frac{3}{2}$ " (1.2 to 8.8 cm).

1. Raise planter to remove weight from wheels.
2. Push down on depth adjustment handle and reposition it forward to decrease or rearward to increase planting depth. Initially adjust all units to the same setting.
3. Lower planter and check operation and planting depth of all row units. Readjust individual rows as needed for uniform operation.

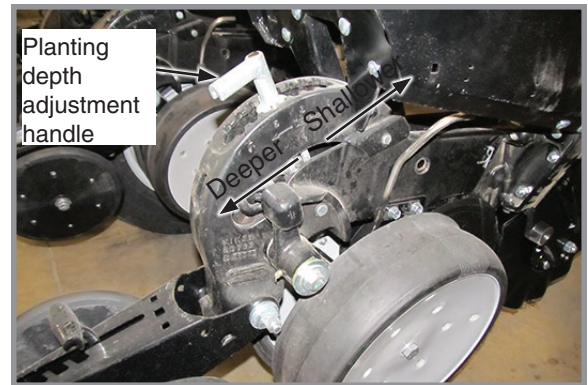

Planting Depth Adjustment

“V” CLOSING WHEEL ADJUSTMENT (RUBBER OR CAST IRON)

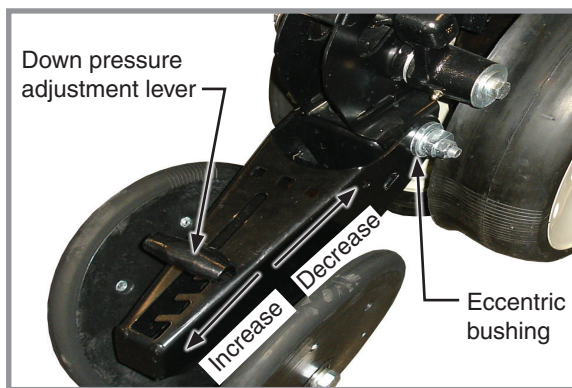

“V” Closing Wheel Adjustments

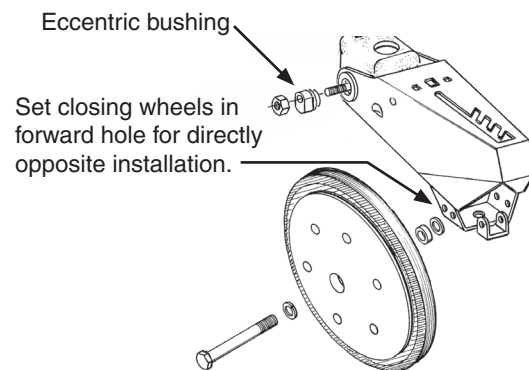

“V” closing wheels should have enough down pressure to close the seed trench and ensure good soil to seed contact. Move 5-position quick adjustable down force lever on the top of closing wheel arm to the rear to increase closing wheel spring pressure. Move lever forward to decrease pressure. Adjust all row units to a similar setting. Light soil usually requires less down force at average depth (approximately 2") while heavy soil requires increased down force.

Eccentric bushings in the wheel arm stop allow for lateral adjustment of the “V” closing wheel assembly. Use a $\frac{3}{4}$ " wrench to loosen hardware attaching closing wheel arm to wheel arm stop. Use another $\frac{3}{4}$ " wrench to turn eccentric bushings until **closing wheels are aligned with seed trench**. Tighten hardware.

Closing wheels can be installed “offset” (to improve residue flow) or “directly” opposite. Use forward installation holes if set “directly” opposite.

CLOSING WHEEL SHIELD (RUBBER OR CAST IRON “V” CLOSING WHEELS)

Optional closing wheel shield is installed on underside of closing wheel arm to help prevent root balls and stalks from clogging closing wheels.

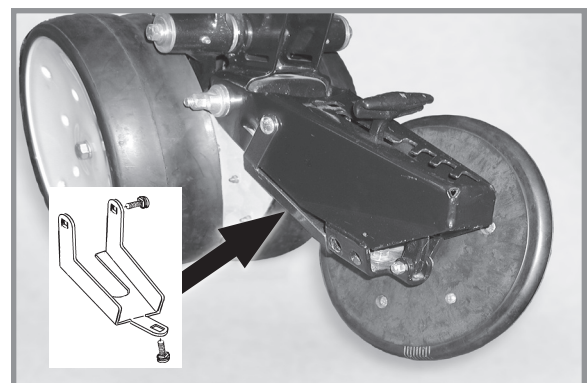

Closing Wheel Shield (closing wheel removed)

COVERING DISCS/SINGLE PRESS WHEEL ADJUSTMENT

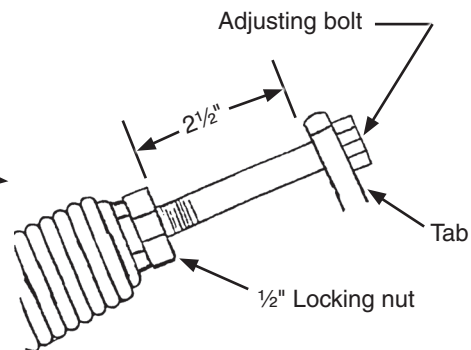
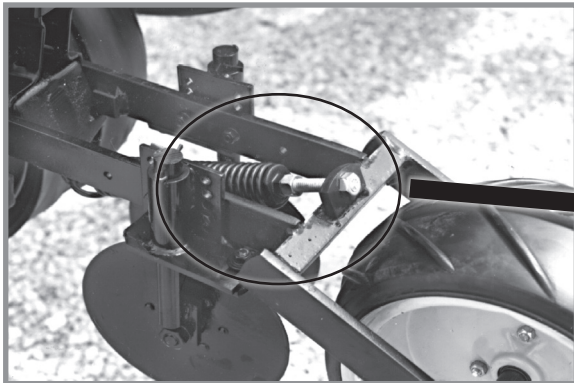

Press Wheel Down Force Adjustment

Check operation of covering discs/single press wheels after adjusting planting depth. Initial press wheel down force spring setting is 2 1/2" between mounting arm tab and locking nut. Loosen 1/2" locking nut and turn adjusting bolt in to increase down force or out to decrease down force. Tighten locking nut against spring plug. Adjust all row units to a similar setting.

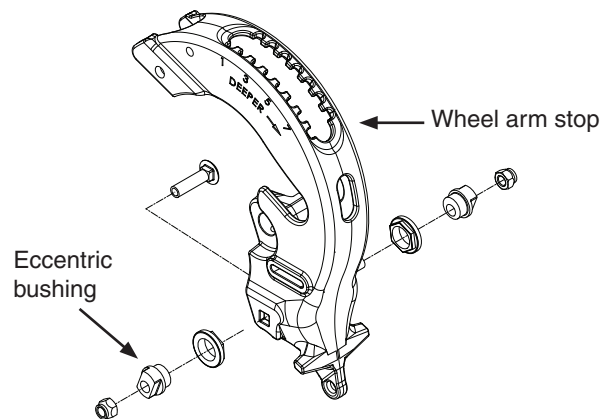
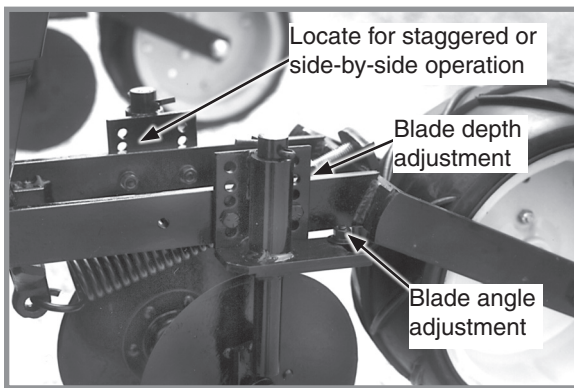

Covering Disc Adjustments

Eccentric bushings in the wheel arm stop allow for lateral adjustment of covering discs/single press wheel assembly. Use a 3/4" wrench to loosen hardware attaching closing wheel arm to wheel arm stop. Use another 3/4" wrench to turn eccentric bushings until covering discs/single press wheel assembly is aligned with seed trench. Tighten hardware. Two sets of holes in mounting arm locate covering discs for staggered or side-by-side operation. Five sets of holes in each disc bracket allow 1/2" incremental blade depth adjustment. Slotted holes in disc mount and bracket allow for 0° - 15° blade angle adjustment. Adjust covering discs on all row units to similar settings.

SEED HOPPERS

Seed hoppers have a capacity option of 1.9 or 3.0 bushels.

NOTE: Planters with the insecticide option are required to use only the 1.9 bushel hoppers.

Use clean seed and make certain there are no foreign objects inside when filling seed hopper. **Replace hopper lids after hoppers are filled to prevent accumulation of dust or dirt in seed meter which can cause premature wear.**

Periodically empty hoppers completely to remove any foreign objects and to ensure proper seed meter operation.



Seed Hopper

Disengage hopper latch and lift hopper off hopper support. Disconnect vacuum meter and drive connections.

QUICK ADJUSTABLE DOWN FORCE SPRINGS OPTION

Standard and heavy duty quick adjustable down force springs are available in increase penetration in hard soil and keep row unit from bouncing in rough field conditions. Two springs per row, one on each side parallel arms, are used unless equipped with row unit mounted no till coulters. Row unit mounted no till coulters require four springs per row.



Two Springs per Row (Dual)

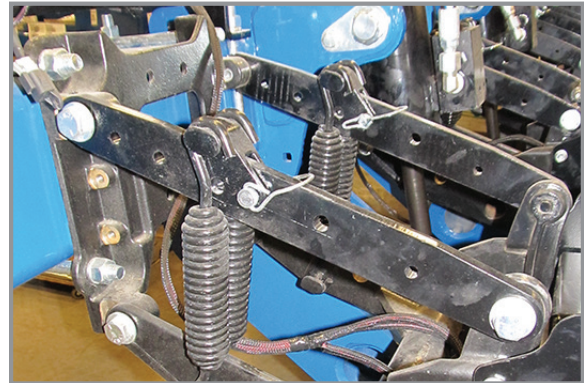

Four Springs per Row (Quad)

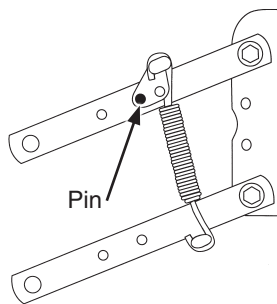

Position 1 (Least)

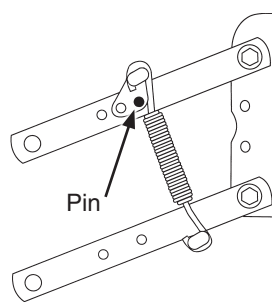

Position 2

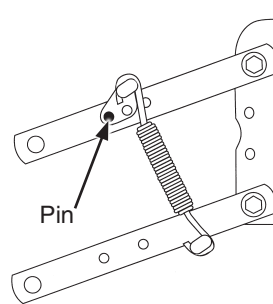

Position 3

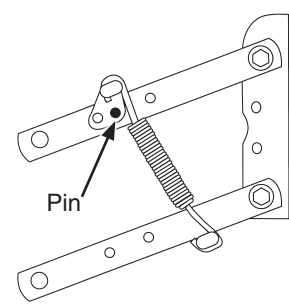

Position 4 (Most)

There are four positions to set down pressure spring tension.

Standard and Heavy Duty Spring Down Force Pressure*				
	2 Springs		4 Springs	
Position	Standard D8249	Heavy Duty D21337	Standard D8249	Heavy Duty D21337
1	41lb (18.6 kg)	43 lb (19.5 kg)	74 lb (33.6 kg)	80 lb (36.3 kg)
2	73 lb (33.1 kg)	86 lb (39.0 kg)	120 lb (54.4 kg)	144 lb (65.3 kg)
3	136 lb (61.7 kg)	167 lb (75.7 kg)	255 lb (115.7 kg)	307 lb (139.3 kg)
4	207 lb (93.9 kg)	249 lb (113.0 kg)	369 lb (167.4 kg)	470 lb (213.2 kg)

*Pressure does not include weight of row unit, seed, or options.

NOTICE	Springs must be installed with open side of spring hooks toward seed hoppers to prevent binding on spring mount adjustment pins.
---------------	---

1. Raise planter and remove spring mount pin at top of spring.
2. Slide mount to desired position and install pin.

NOTE: Adjust springs for field conditions. Too much down pressure in hard field conditions can cause row units to lift planter and keep drive wheels from making contact. Too much down pressure in soft field conditions can cause row unit to run too deep.

PNEUMATIC DOWN PRESSURE

Row unit down pressure can be adjusted on-the-go as field conditions change. ISOBUS monitor adjusts pressure (Older models may have a digital readout). One planter-mounted 12 VDC air compressor with 3-gallon capacity air tank supplies air for the down pressure system.

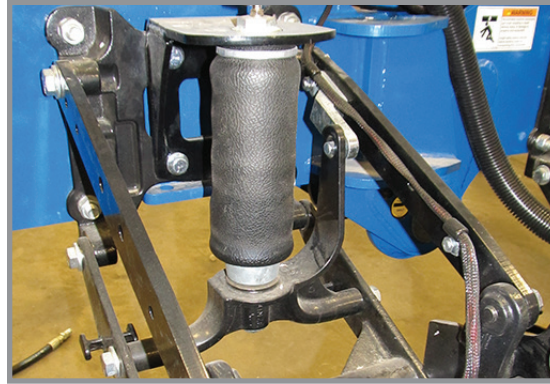

Row Unit Air Spring

Packages include upper and lower air spring mounting castings for pull row units, 150 psi rated air springs, $\frac{3}{8}$ " O.D. nylon hoses, dual solenoid air valve and stainless steel, 160 psi, 2" liquid-filled gauge and planter wiring harness.

NOTE: Assist springs are available through your Kinze dealer if additional down pressure is needed.

TEMPERATURE SENSOR OPTION

A ground temperature sensor option is available on ISOBUS equipped planters.

The sensor should be installed on the following rows, depending on your row size:

- 12 Row - Row 6
- 16 Row - Row 8
- 24 Row - Row 12

The sensor must be adjusted up or down until it is $\frac{5}{8}$ " above seed tube opening.

Refer to IS842 for additional installation information.

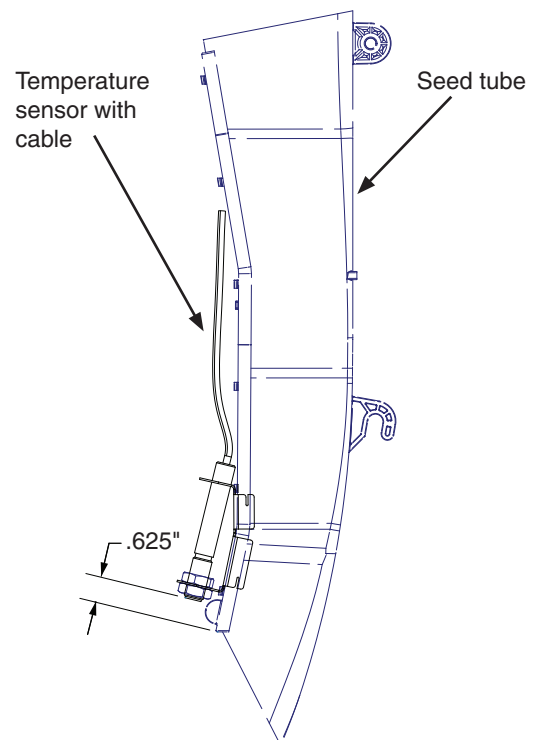

FIELD OPERATION

NOTE: Adjust down pressure with planter lowered and row openers in ground for most accurate adjustment. Pressure can be adjusted using your ISOBUS monitor. Refer to the ISOBUS manual for more information.

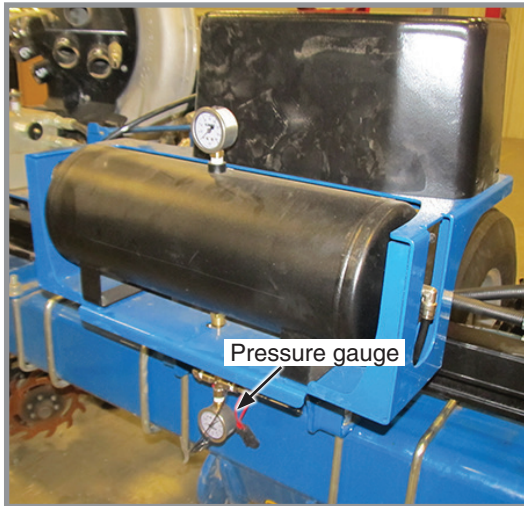

Air Compressor

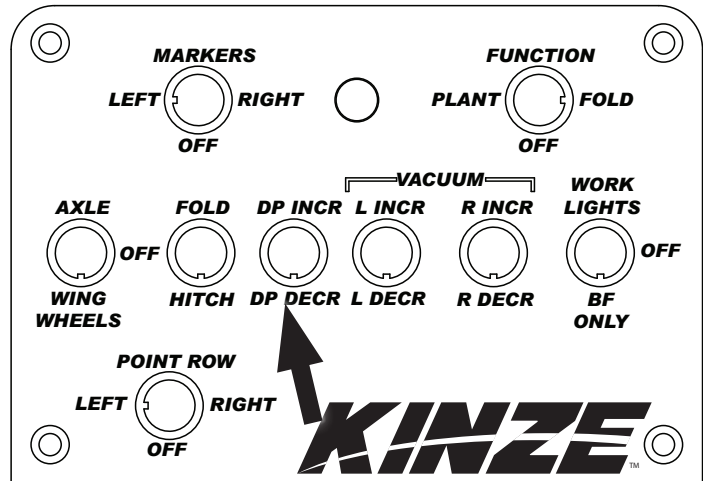

Control Box

ADJUST DOWN PRESSURE FROM CAB

For models equipped with an ISOBUS monitor, use the monitor to adjust down pressure. Refer to your ISOBUS manual for more information.









For models equipped with a control box, toggle the Down Pressure Switch up or down to increase or decrease down force.

MANUAL RUN BUTTON



Use the manual run button to turn on seed meter, fertilizer and insecticide on each row unit to check functionality.

VACUUM SETTINGS

Crop		**Seed Disc Kit	Seed Disc Part No.	Ejector Wheel (Color)	Cells	Seed Size Range	Singulator Zone Setting	Vacuum Setting Inches of Water (kPa)	Lubricant
	Corn ‡ Large Sweet Corn	G9040X	B0678 (Light Blue)	1 row 5 punches (Light Blue)	40	35-70 lbs/80k (2500-5000 seeds/kg)	2	18-20 (4.5-5.0)	Graphite* Talc* Bayer Fluency† (if mandated)
	Soybean	G9041X	B0848 (Black)	2 rows 6 punches (Black)	120	2200-4000 seeds/lb (4850-8820 seeds/kg)	0	10-14 (2.5-3.5)	Graphite* Talc* Bayer Fluency† (if mandated)
	Sugar Beet	G9043X	B0683 (Dark Orange)	1 row 6 punches (Dark Orange)	60	Pelletized	2	15 (3.75)	Graphite* Talc* Bayer Fluency† (if mandated)
	Milo	G9043X	B0683 (Dark Orange)	1 row 6 punches (Dark Orange)	60	10,000-20,000 seeds/lb (22000-44000 seeds/kg)	2	15 (3.75)	Graphite* Talc* Bayer Fluency† (if mandated)
	Sunflower ‡ Small Sweet Corn	G9042X	B0684 (Gray)	1 row 5 punches (Gray)	40	Oil seeds #2, 3, 4	2	12-18 (3.0-4.5)	Graphite* Talc* Bayer Fluency† (if mandated)
	Sunflower	G9042X	B0684 (Gray)	1 row 5 punches (Gray)	40	Oil seeds #5	2	5-8 (1.25-2.0)	Graphite* Talc* Bayer Fluency† (if mandated)
	Specialty Disc 1	G9272X	B0912 (Green)	1 row 6 punches (Green)	60	Cotton	2	15-20 (3.75-5.0)	Graphite* Talc as needed* Bayer Fluency† (if mandated)
	Specialty Disc 2	G9273X	B0914 (Brown)	1 row 6 punches (Green)	60	Black turtle & navy edible beans	2	15-20 (3.75-5.0)	Graphite* Talc as needed* Bayer Fluency† (if mandated)
	Specialty Disc 3	G9308X	B0913 (Dark Blue)	1 row 6 punches (Green)	60	Pinto & Great Northern edible beans & low-rate soybean	2	15-20 (3.75-5.0)	Graphite* Talc as needed* Bayer Fluency† (if mandated)

Install selected seed disc. Position vacuum cover on meter by aligning keyhole slots over bolt heads. Push cover on meter and turn counter clockwise to lock in place.











*For More information on application rate, see Additives section.

**Includes seed disc, ejector wheel, and spring.

†Bayer Fluency Agent is only required to be used in place of graphite or talc lubricants on vacuum equipped planters that are sowing neonicotinoid treated seeds in Canada. Refer to the Bayer Fluency Agent section for more information.

‡Conventional hoppers only, not applicable with bulk fill.

BRUSH-TYPE SEED METER

	Crop	Disc Color-Code (Disc Part No.)	Upper Brush Retainer	Cells	Seed Size Range	*Lubricant
	Soybean	Black (GA5794)	GD11122	60	2200 to 4000 seeds/lb. (4480 to 8800 kg)	Graphite Talc
	Specialty Soybean	Dark Blue (GA6184)	GD11122	48	1400 to 2200 seeds/lb. (3080 to 4840 kg)	Graphite Talc
	Small Milo/Grain Sorghum	Red (GA5982)	GD8237	30	14,000 to 20,000 seeds/lb. (30800 to 44000 kg)	Talc
	Large Milo Grain Sorghum	Light Blue (GA6187)	GD8237	30	10,000 to 16,000 seeds/lb. (22000 to 35200 kg)	Talc
	High-Rate Small Milo/ Grain Sorghum	Red (GA5795)	GD8237	60	12,000 to 18,000 seeds/lb. (26400 to 39600 kg)	Talc
	High-Rate Large Milo/ Grain Sorghum	Yellow (GA6633)	GD8237	60	10,000 to 14,000 seeds/lb. (22000 to 30800 kg)	Talc
	Cotton, Acid-Delinted	White (GA5796)	GD11122	30	4200 to 5200 seeds/lb. (9240 to 11440 kg)	Talc
	Large Cotton, Acid Delinted	Tan (GA6168)	GD11122	36	3800 to 4400 seeds/lb. (8360 to 9680 kg)	Talc
	High-Rate Cotton, Acid-Delinted	Light Green (GA6478)	GD11122	48	4200 to 5200 seeds/lb. (9240 to 11440 kg)	Talc
	Hill-Drop Cotton, Acid-Delinted	Brown (GA6182)	GD11122	12 (3 to 6 seeds/ cell)	4000 to 5200 seeds/lb. (8800 to 11440 kg)	Talc
	Small Hill-Drop Cotton, Acid-Delinted	Dark Green (GA7255)	GD11122	12 (3 to 6 seeds/ cell)	5000 to 6200 seeds/lb. (11000 to 13640 kg)	Talc

*For More information on application rate see Additives section.

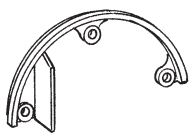

Use GD11122 upper brush retainer when using cotton and soybean discs.

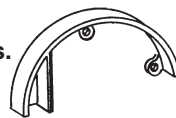

Use GD8237 upper brush retainer when using milo/grain sorghum discs.

Turn seed disc counterclockwise when installing on meter hub while tightening two wing nuts that retain disc. Seed disc should have slight resistance when rotated counterclockwise after wing nuts are tight.

Brush-type seed meter attaches to seed hopper same as finger pickup seed meter. Secure to bottom of seed hopper with two 5/16" thumbscrews. Tighten thumbscrews slightly with pliers. **DO NOT OVER TIGHTEN.**

Misalignment between drive coupler and seed meter input shaft may cause erratic seed spacing from momentary stoppage of seed disc. Check alignment and adjust as needed.

Refer to planting rate charts in this manual for recommended seed drive transmission sprocket combinations.

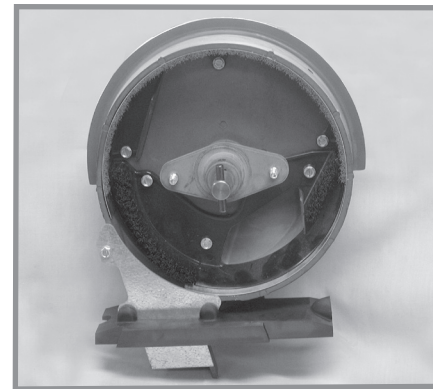





Shown without seed disc installed

NOTICE	Replace hopper lids after hoppers are filled to prevent accumulation of dust or dirt in seed meter which will cause premature wear.
---------------	--

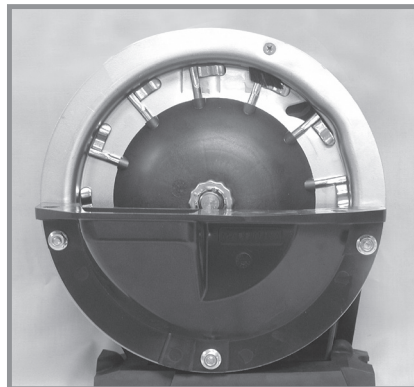
NOTE: Clean seed is required to ensure accurate seed metering from brush-type seed meters. Remove seed discs daily and check seed meter or brushes for buildup of foreign material, such as hulls, stems, etc.

FINGER PICKUP SEED METER

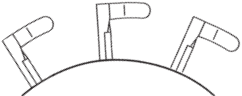

Crop	Fingers	*Lubricant
Corn	 Part No.: GR1848 - Finger Assembly, Corn	Graphite Talc
No. 1 and/or No. 2 size Confectionery Sunflower Seeds	 Part No.: GR1848 - Finger Assembly, Corn	Talc
No. 3 and/or No. 4 size Oil Sunflower Seeds	 Part No.: GR1897 - Finger Assembly, Oil	Talc
Blank fingers replace alternate fingers to reduce planting rate by half while allowing the finger wheel to maintain a minimum of 40 RPM when planting low rates.	 Part No.: GD11787 - Half Rate Blank Finger	Graphite Talc

***For More information on application rate see Additives section.**

NOTE: Always field check seed population to verify planting rates.

NOTE: Refer to planting rate charts in this manual for recommended seed drive transmission sprocket combinations.

NOTE: See [“Master Module” on page 2-64](#) for more information. Always field check seed population to ensure planting rates are correct.

NOTE: Singulator settings are marked from 0 - 3.

NOTE: Mixing seed sizes and shapes affects meter performance. Use consistent seed size and shape.

NOTE: Use 1 tablespoon powdered graphite with each standard hopper fill of seed. Seed treatment, foreign material, dirt or seed chaff may cause gradual reduction of seed disc fill (population). See “Additives” pages for more information.

NOTE: Excessive seed treatment, humidity, and light-weight seed can affect meter performance. Use ½ cup of talc with each standard hopper fill of seed and mix thoroughly to coat all seeds and adjust rates as needed. Use of talc aids seed flow into meter, singulation, and disc seed drop.

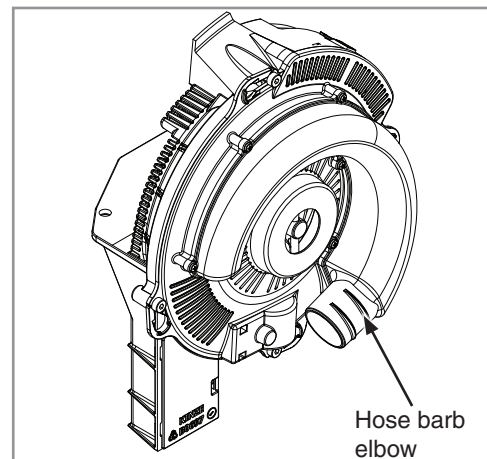
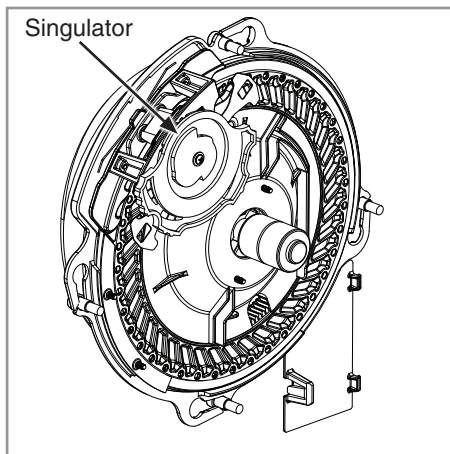

NOTE: Foreign material in seed disc orifices, such as seed chips, hulls, stems, etc., may affect seed delivery. Clean seed ensures accurate seed metering from vacuum seed meter. Remove Seed discs daily to check for buildup of foreign material in seed disc orifices.

Air inlet screens allow air to enter system and aids in keeping field residue or other foreign material out of meter.

See [“Vacuum Seed Meter Maintenance” on page 6-18](#) and [“Preparation for Storage” on page 6-33](#) in Lubrication and Maintenance section for more information.

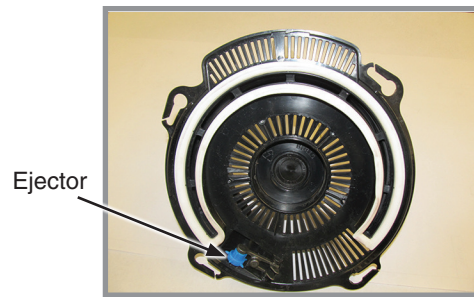

NOTE: Damaged seed or seed containing foreign material will cause plugging of seed disc orifices and require more frequent seed meter cleanout to prevent underplanting.

Wheel-Type Ejectors

Wheel-type ejectors expel seed remnants from seed disc orifices. These ejectors are disc specific and colored coded to match disc.

NOTICE

Replace hopper lids after hoppers are filled to prevent accumulation of dust or dirt in seed meter which will cause premature wear.

NOTE: Seed size, seed shape, seed treatments, travel speed, and planting rate affect meter performance.

1. Select seed disc and ejector to match crop and population.

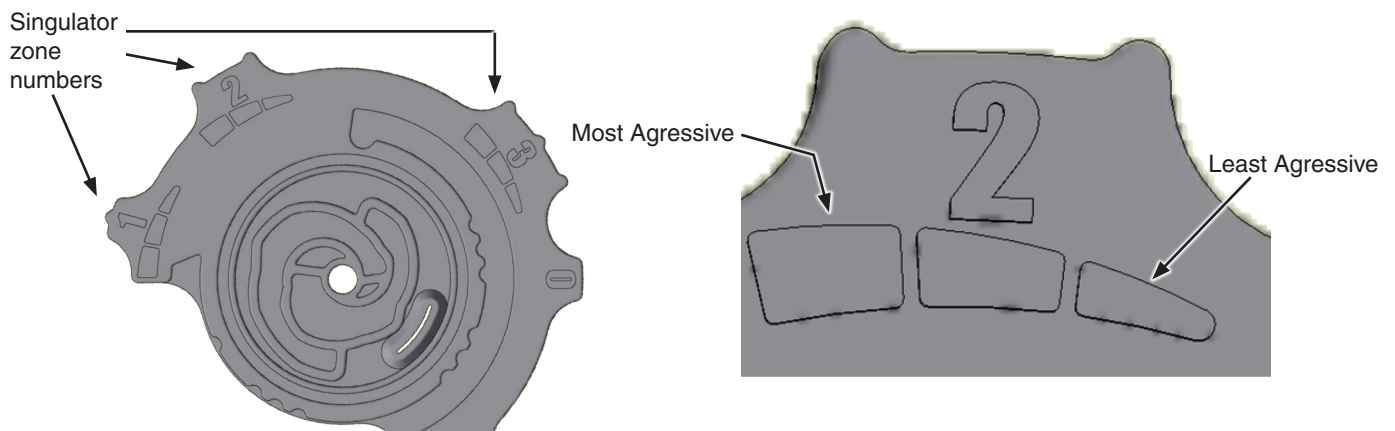

Singulator Adjustment Wheel

2. Adjust singulator wheel to initial setting. Seed size, seed shape, seed treatments, travel speed and planting rate all affect meter performance.
3. With vacuum fan running, lower planter to planting position and drive forward a short distance to load seed into seed disc cells.
4. Adjust vacuum level to initial setting according to tables on page.

NOTE: Vacuum reading will be much lower when seed disc cells are empty. Load all seed cells before setting vacuum level.

NOTE: Operate vacuum fan 3-5 minutes to bring oil up to normal operating temperature prior to making final vacuum level adjustment.

SEED METER CLEANOUT

NOTE: Use of damaged seed or seed containing foreign material will cause plugging of seed cell orifices and require more frequent seed meter cleanout to prevent underplanting.

Thorough seed meter cleanout is important to maintain genetic purity.

1. Disengage seed drive and remove seed hopper and meter.
2. Dump seed from right rear corner of hopper into a container.
3. Lay hopper on its right side. Push release button and rotate seed meter vacuum cover clockwise to align keyhole slots with bolt heads. Lift off cover.
4. Rotate seed disc hub clockwise to unlock and remove seed disc.
5. Empty meter.
6. Thoroughly inspect meter to ensure all seed is removed.
7. Replace seed disc. Install vacuum cover.

ADDITIVES

The use of graphite is recommended to promote seed flow, provide lubrication for the seed meter and to help dissipate static charge buildup. Among the available dry seed lubricants graphite is the most effective and easiest to use and it requires no mechanical agitation

CONVENTIONAL HOPPERS

Mix one tablespoon of **powdered graphite** with seed each time hoppers are filled. Regular graphite use prolongs life of the seed meter components, improves seed spacing, and may reduce buildup of seed treatments.

NOTE: DO NOT apply graphite only in center of hopper. It will filter too quickly through the seed and not distribute as evenly as desired.

Apply graphite around outer perimeter of hopper.

BULK FILL HOPPERS

Mix 1 pound bottle of powdered graphite each time the bulk seed hopper is filled. Graphite should be added in layers as the bulk seed hoppers are filled. Regular graphite use prolongs life of the seed meter components, improves seed spacing, and may reduce buildup of seed treatments.



Adding graphite to conventional hopper



Adding graphite bulk fill hopper

NOTE: Additional graphite may be required to retard buildup of seed treatments on meter components. More frequent cleaning of monitor seed tubes may be necessary due to use of additional graphite.

Talc seed lubricant may be used as a drying agent in addition to graphite lubrication. The drying agent may improve seed release and/or **to retard buildup of seed treatments on meter components.**

1. Fill hopper $\frac{1}{2}$ full of seed, add $\frac{1}{4}$ cup (conventional); 2 pounds (Bulk Fill) of talc and **mix thoroughly.**
2. Finish filling hopper, add another $\frac{1}{4}$ cup (conventional); 2 pounds (Bulk Fill) of talc and **mix thoroughly.**
3. Adjust rate of talc use as needed so all seeds are coated, while avoiding a buildup of talc in bottom of hopper.

Humid conditions and/or small sized seeds with extra seed treatment may require additional talc to maintain meter performance.

NOTE: Liquid seed treatments or inoculants may create buildup on the seed disc or brushes. Check frequently for proper population and/or seed delivery when using any liquid seed treatment.

Completely mix all treatments with seed following manufacturers' recommendations. Seed treatment dumped on top of seed after hopper is filled may not mix properly and cause seed bridging, reducing population or stopping meter from planting.

Lubricant Application Rate	
Graphite	
Conventional Hoppers	1 Tbs./Hopper Fill
Bulk Fill Hoppers	1 Pound Bottle/Hopper
Talc	
Conventional Hoppers	$\frac{1}{4}$ C.*
Bulk Fill Hoppers	4 Pounds/Hopper*
*Double amount of talc for sunflowers.	

BAYER FLUENCY AGENT

Bayer Fluency Agent is an alternate seed lubricant by Bayer Crop Science. The intent of this product is to replace graphite and talc lubricants and to lower the amount of dust emissions from planter vacuum fans.

This product, as tested by Kinze, is compatible with Kinze's bulk fill system and vacuum meters. Due to limited testing, wear life characteristics of meters and bulk fill systems that use Bayer Fluency Agent are not yet known. Please follow Bayer Fluency Agent instructions for rates and mixing directions.

NOTE: Presently, Bayer Fluency Agent is only required to be used in Canada with Bulk Fill or Vacuum planters that plant corn or beans treated with neonicotinoids. Farms outside of Canada, farms not using seed treated with neonicotinoids, and farms not using pneumatic metering devices do not need to use Bayer Fluency Agent. All planters not equipped with vacuums or fans are exempt from using Bayer Fluency Agent.

SPIKED CLOSING WHEEL

Spiked closing wheels crumble the sidewall, allowing roots to penetrate soil. They can be used on pull row units and push row units.

Align spiked closing wheels straight across from each other, in most rearward holes on closing wheel arm. Set the wheels 1" - 1¼" (2.5 - 3.1 cm) apart at the closest point. If large amounts of contouring is being done, mount wheels in the forward most hole. This will reduce drifting of row unit.

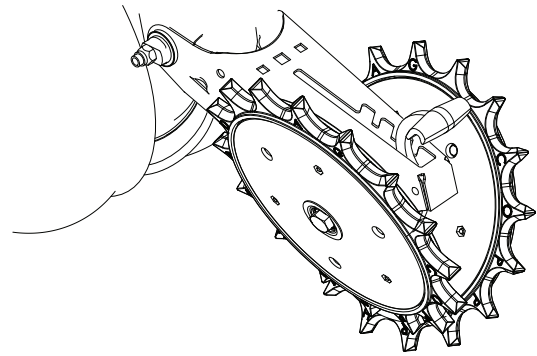

Row Unit Spiked Closing Wheel

ROW UNIT MOUNTED NO TILL COULTER

Row unit mounted no till coulters with 1" bubbled, 1" fluted (8 flutes) or ¾" fluted (13 flutes) blades may be used on row units (¾" fluted shown). Four quick adjustable down force springs are required per row when using row unit mounted no till coulters. See ["Quick Adjustable Down Force Springs Option" on page 3-4](#).

Coulter blade can be adjusted to one of four ½" incremental settings in the forked arm. Initial location is the top hole.

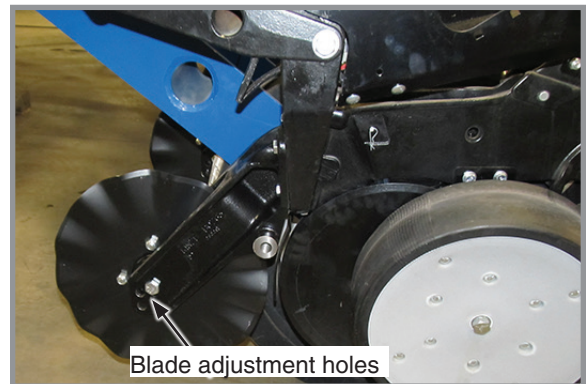

Row Unit Mounted No Till Coulters

Move blade as it wears to one of the three lower hole to maintain coulters blade at or slightly above opener discs. Adjust coulters below depth of double disc opener blades in very hard soil conditions such as compacted wheel tracks to improve opener penetration and cutting of surface residue.

Check operating depth by setting planter down on a level concrete floor and checking relationship between coulters blade and row unit opener blade. Make sure planter is level and coulters is square with planter frame and aligned with row unit disc opener.

NOTE: Torque 5/8" spindle hardware to 120 ft-lb (162.7 N-m).

GFX HYDRAULIC ROW CLEANERS



WARNING

Pressurized hydraulic fluid can penetrate body tissue and result in death, serious infection, or other injuries. Fluid injected under skin must be IMMEDIATELY removed by a surgeon familiar with this type of injury. Make sure connections are tight and hoses and fittings are not damaged before applying system pressure. Leaks can be invisible. Keep away from suspected leaks. Relieve pressure before searching for leaks or performing any system maintenance.



Run the minimum flow rate necessary. Generally this is a setting of .5-.7 with maximum ever being used being about 1.5. This is on a scale of 1-10, most tractors will be using less than 10% of available flow. Any additional flow will simply waste power and also increase stress and temperature on control manifold, valves and also the tractor oil temperature.

BLEEDING HYDRAULIC CIRCUIT AND INITIAL OPERATION

Gfx hydraulic row cleaners were designed to bleed the hydraulic circuit by purging air out of system from either end of tool bar. In practice it will be virtually impossible to completely bleed system in the shop. A certain amount of air will need to work itself out over time. To sufficiently bleed the system use the following procedure.

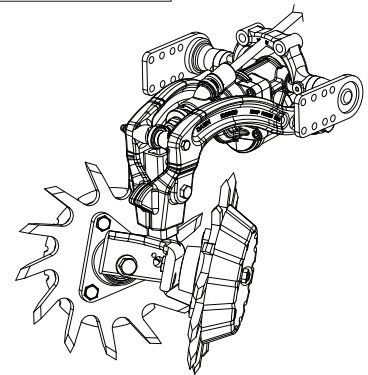

1. Make sure that pressure setting in system is set to it's minimum by moving pressure control knob on control box counter-clockwise until it stops, or in the (0) setting. A minimum amount of pressure should be running during bleeding process.
2. Using the 1/16" cap nut at each end of the tool bar, open BOTH ends slightly at this time.
3. Keep knob on Dawn digital control box at zero and tune the tractors SCV hydraulic control to 1-2 GPM (gallons per minute) or at about 5% of maximum flow.
4. Gradually increase pressure setting on electronic control knob until a slow steady stream of fluid is flowing from bleed adapters. There should be surging coming out of bleed adapters at this point. Continue the bleed process until surging stops and clean fluid begins coming out.
5. When clean hydraulic fluid flows freely from bleed adapter, close bleed valves. Cycle circuit a few times using digital control knob, then re-open 1/16" cap nuts to release air bubbles.

START UP

1. Turn on SCV to hydraulic row cleaner.
2. Turn row cleaner adjustment dial to zero, and then turn on electrical switch on side of control box.
3. Adjust dial on control box to achieve desired down force; clockwise to increase, counter-clockwise to decrease.
4. To operate turn control knob and apply as much pressure as necessary to achieve desired level of row cleaning.

SHUT DOWN

1. Turn row cleaner adjustment dial to zero.
2. Always turn electrical power switch on side of control box to off position before turning off tractor hydraulic SCV.

NOTE: Failure to follow this order will trap pressure in the row cleaner hydraulic accumulators.

3. Turn off tractor SCV.

COULTER OR ROW UNIT MOUNTED RESIDUE WHEELS

Coulter mounted or row unit mounted residue wheels are designed for use on row units.

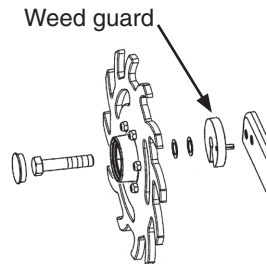

NOTE: Opening in weed guard must face down.



Coulter Mounted Residue Wheels

Residue wheels attach to row unit mounted coulter with two cap screws and sleeves allowing unit to free-float. A 2-position spindle bolt mounting positions wheels interlocked or staggered. Depth adjustment is made with a spring-loaded cam and pin with 11 positions in $\frac{1}{4}$ " increments. A high point on the cam allows wheels to be locked up.

A weed guard on the inboard side of each wheel helps prevent weed wrap which can cause premature bearing failure.

GRANULAR CHEMICAL BANDING OPTIONS

Granular chemical banding options allow $4\frac{1}{2}$ " slope-compensating banding, straight drop in-furrow placement or 14" rear banding.

NOTE: Granular chemical rear bander is not compatible with covering discs/single press wheel option.

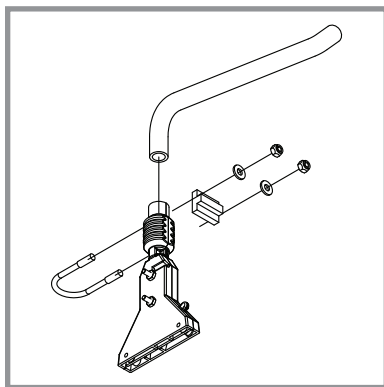

$4\frac{1}{2}$ " Slope-compensating Bander

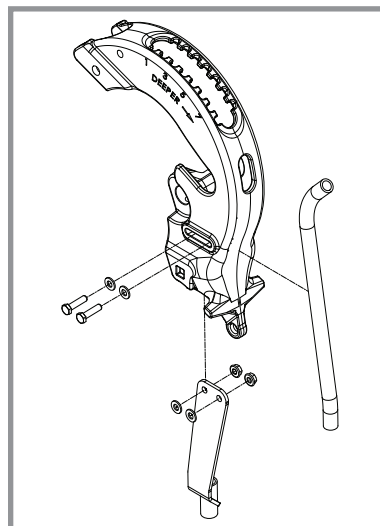

Straight Drop In-furrow Placement

GRANULAR CHEMICAL HOPPER AND DRIVE

WARNING



Agricultural chemicals can cause death or serious injury to persons, animals, and plants or seriously damage soil, equipment, or property. Read and follow all chemical and equipment manufacturers labels and instructions.

NOTICE

Do not store granular products in granular chemical hoppers. High humidity or rain may cause stored granular products to bind and block the product from flowing.

The granular chemical hopper has a 1.4 cubic feet capacity.

Make sure no foreign objects get into hopper when it is being filled. Replace hopper lids after filling to prevent accumulation of dirt and moisture.

A metering gate on bottom of hopper regulates the application rate. See “Dry Insecticide and Dry Herbicide Application Rate Charts” in this manual. Calibrate using chemical manufacturers’ instructions.



Granular Chemical Hopper

Granular chemical clutch drive coupler and meter shaft can be disengaged and engaged by turning throwout knob at rear of hopper support panel.

Rotate knob $\frac{1}{4}$ turn counterclockwise to disengage and $\frac{1}{4}$ turn clockwise to engage.

Slotted holes in hopper support panel and clutch housing allow for alignment adjustment between clutch drive coupler and meter shaft.

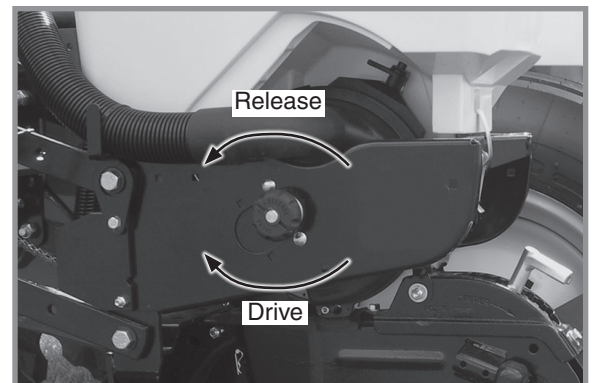

Granular chemical drive release

This page intentionally blank.

SYSTEM OVERVIEW

Fertilizer is controlled through the Virtual Terminal on your Advanced ISOBUS. You can increase or decrease fertilizer rate, turn fertilizer function on or off, and load a prescription. Refer to your Advanced ISOBUS manual for more information.

CENTRIFUGAL PUMP

NOTE: Keep manuals shipped with centrifugal pump with this manual.

The centrifugal pump operates off hydraulics from the bulk fill remote, which can be identified by yellow labeled hoses. It uses a common rail delivery system with orifice and control valve to achieve desired fertilizer rate. The fertilizer pump is factory set and has a hydraulic requirement of 4 gpm (15 Lpm).

Operating pressure while operating in the field should be 30-40 psi (207 - 276 kPa). The orifice size installed at the factory is 0.037". If a different rate or travel speed is desired, use rate chart and install orifices for your rate. Refer to ["Fertilizer Rates - Centrifugal Pump and Piston Pump with Manifolds" on page 5-15.](#)

The centrifugal pump should be running when:

- Bulk fill remote is on (identified by yellow hoses)
- Master switch is on
- Fertilizer is turned on in the fertilizer section of your ISOBUS system

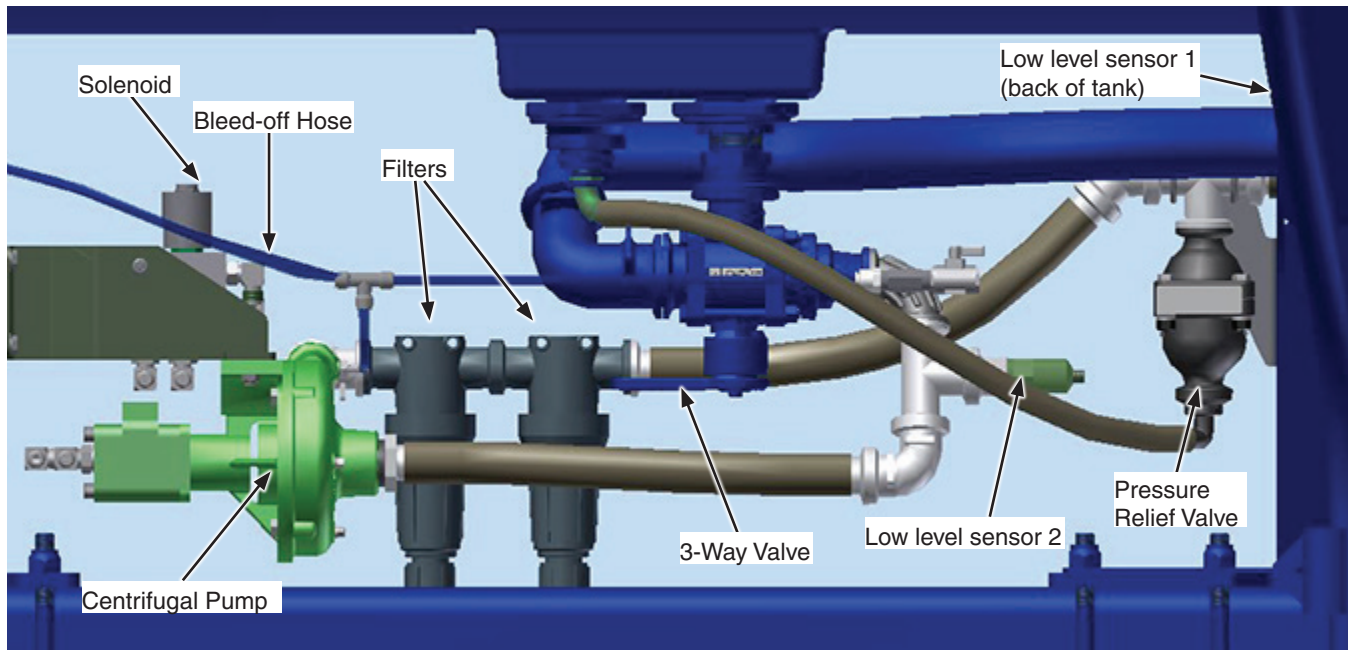

Underneath Fertilizer Tank

Solenoid allows oil to go to centrifugal pump and turn. It is controlled from the Master Module on the planter.

Safety Relay (not shown) shuts off the pump when no fluid is sensed in the lower Low Level Sensor.

Low Level Sensor 1 is located on back of tank and signals in the cab when tank fluid level is low.

Low Level Sensor 2 is located in the tee fitting after 3-way valve and prevents pump from running when fluid level in tank is too low.

Centrifugal Pump is hydraulically driven and pumps fertilizer to the manifold rail delivery system.

3-Way Valve has three positions for filling the tank. Use the "FILL" position to fill the tank. Use the "PUMP" position while operating. "OFF" turns the tank off.

Pressure Relief Valve is a 100 psi (689 kPa) relief valve that allows liquid to return to the tank when valves are shut off on all rows.

Bleed-off Hose is used for preventing or eliminating air-locking the centrifugal pump.

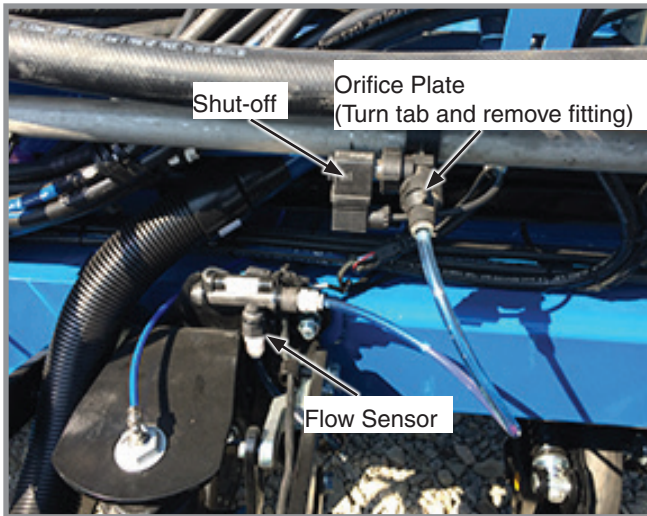

On Toolbar at Row

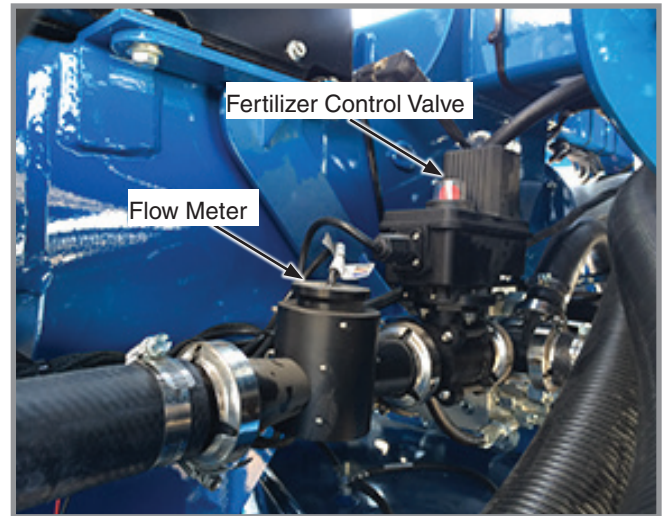

Underneath Bulk Fill Tank

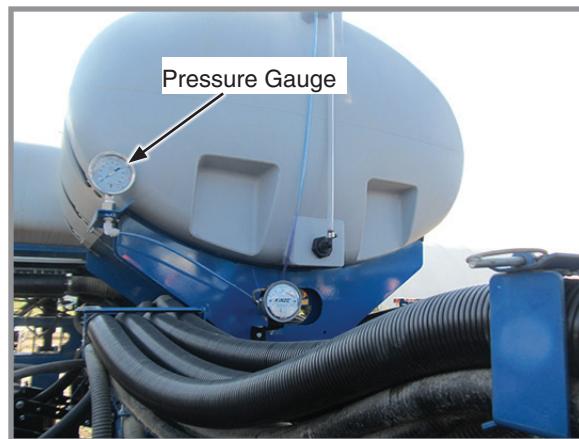

Flow Meter measures fertilizer rate when operating in the field and is displayed in the tractor cab.

Fertilizer Control Valve controls the fertilizer rate and changes rate with change in speed from input from the flow meter.

Shut-off 24 volt shut-off stops fertilizer when coming into a planted area.

Flow Sensor functions as a blockage sensor to signal operator when there is a blockage or no fertilizer flow when there should be. Flow sensor does not indicate rate.

Orifice Plate is factory installed with a 0.037" diameter. To access the orifice, turn the tab counterclockwise and remove the fitting and tube.

Pressure Gauge is located on the tank. On some models, the pressure gauge may be located on the end of the toolbar.

PISTON PUMP

NOTE: Keep manuals shipped with piston pump and flow divider with this manual.

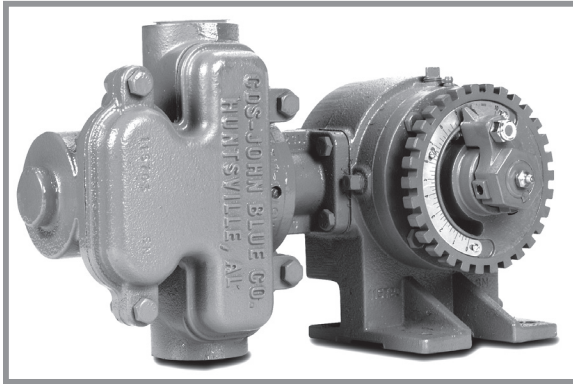

Piston pump

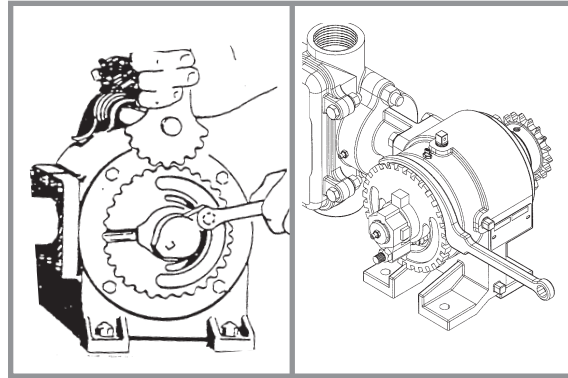

Adjusting delivery rate

NOTE: Delivery rate chart in Rate Chart section of this manual provides approximate application rate only. Delivery varies with temperature and fertilizer.

Loosen $\frac{3}{8}$ " lock nut that secures arm with pointer and rotate scale flange with adjustment wrench until pointer is over desired scale setting. Tighten $\frac{3}{8}$ " lock nut. DO NOT OVERTIGHTEN.

NOTE: Periodically check flow to all rows. Set rate is delivered to remaining rows if one or more lines are plugged.

PISTON PUMP GROUND DRIVE WHEEL SPRING ADJUSTMENT

Initial down pressure spring tension on piston pump ground drive wheel, is set leaving $12\frac{1}{4}$ " between the bottom of mounting plate and plug on top of spring. This dimension is taken with planter raised (tire not contacting the ground). Further adjustment can be made to fit conditions.

NOTE: Piston pump ground drive wheel assembly can be locked in raised position when not in use. Remove two cap screws that attach upper end of spring to spring mount. Reattach spring using upper holes in spring mount. Reverse procedure to reset for field use.

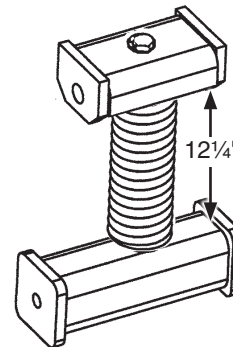

CLEANING

Clean tanks, hoses, and metering pump thoroughly with water at end of planting season or prior to an extended period of non-use. Do not allow fertilizer to crystallize from cold temperature or evaporation.

On machines equipped with piston pump, take apart and clean strainer located between piston pump and ball valve daily. Remove the end cap to clean the screen. See Piston Pump Storage in Maintenance Section of this manual.

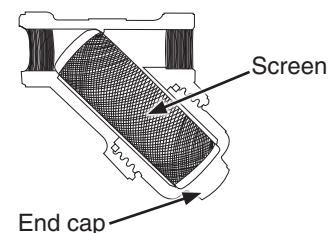

NOTCHED SINGLE DISC OPENERS

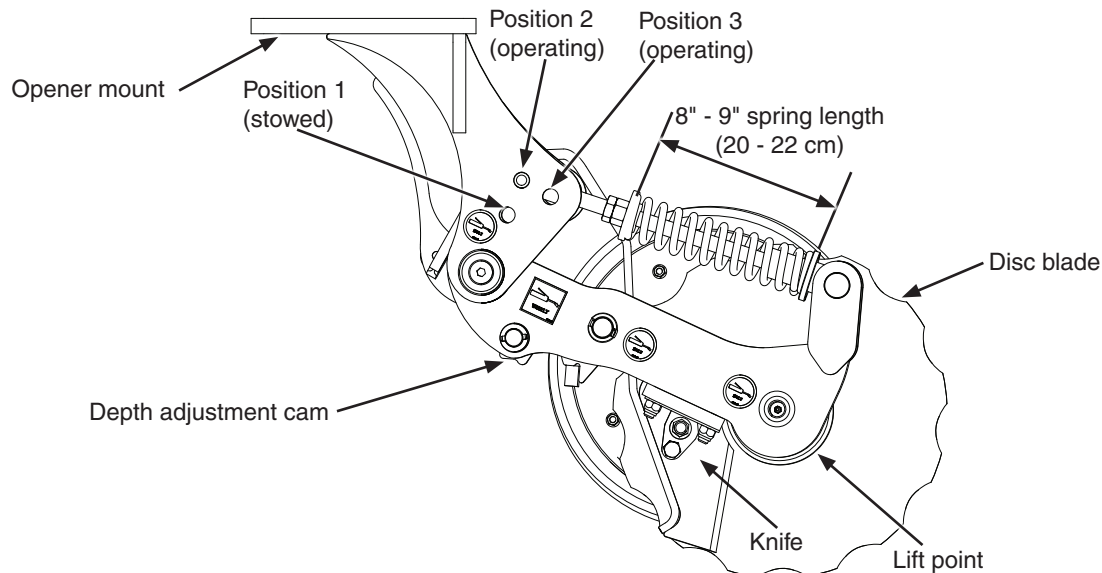

Notched single disc opener adjustments

NOTICE

Never place fertilizer closer than 2" (5 cm) to row or seeds may be damaged.

The openers can be placed in three positions - stowed and two operating positions to match field conditions.

NOTE: Opener will rest in positions 1 and 3, but will need to be held in position 2 until pinned. Ensure opener is supported prior to removing handle pin from position 2.

To change opener position, grasp opener with one hand directly below coulter bearing. With free hand, remove lynch pin and handle pin from opener. Pull up on opener slightly and lift spring tee out of current location. Lower the opener until the tee rests in the desired position. Install handle pin into desired hole position, passing the pin through the spring tee. Re-install lynch pin to lock in place.



Fertilizer depth is adjustable from approximately 2" to 4" (5 to 10 cm) when planter frame is level and at proper 24" (61 cm) operating height. Soil conditions will affect fertilizer placement depth. **Do not place fertilizer any closer than 2" (5 cm) to either side of row.**

NOTE: The opener is designed to operate with the gauge wheel as the primary depth stop when in position 3. In softer conditions, position 2 can be used to control depth using the gauge wheel as well as planter frame to limit opener travel. In all positions, the opener will spring up when encountering a foreign object or hard ground.

GAUGE WHEEL DEPTH ADJUSTMENT

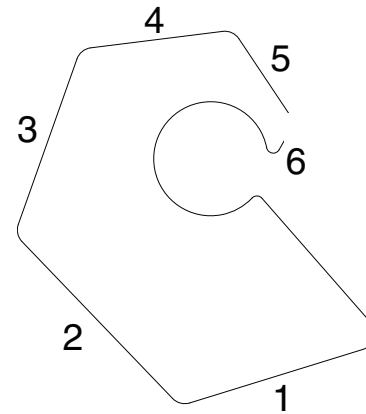
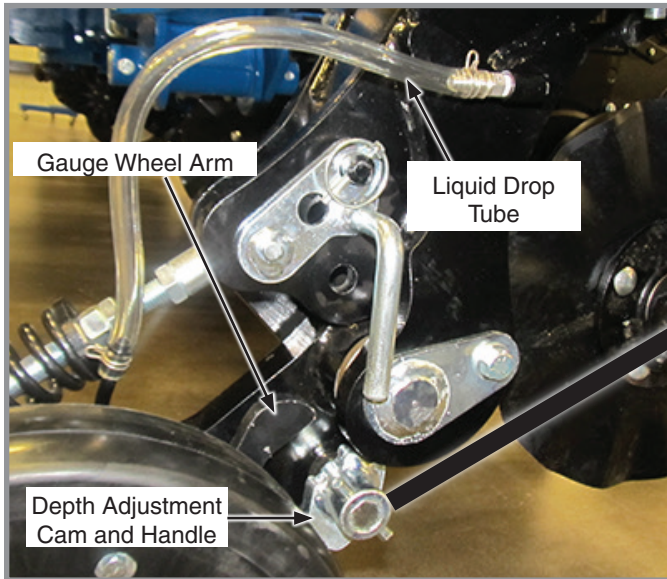

Depth Adjustment Cam Positions

Cam Position	Depth
1	2" (5 cm)
2	2.4" (6 cm)
3	2.8" (7.1 cm)
4	3.2" (8.1 cm)
5	3.6" (9.1 cm)
6	4" (10 cm)

Rotate the depth adjustment cam to adjust depth of fertilizer placement into the soil.

Pull out the handle and rotate the depth adjustment cam in 60° increments to achieve desired depths. There are six depths available, with 2" (5 cm) as the shallowest option and 4" (10 cm) as the deepest from the ground surface. Refer to the illustration and chart above.

NOTE: Depth gauge values are approximate and can vary greatly depending on actual field conditions and adjusted position.

DOWNFORCE SETTINGS

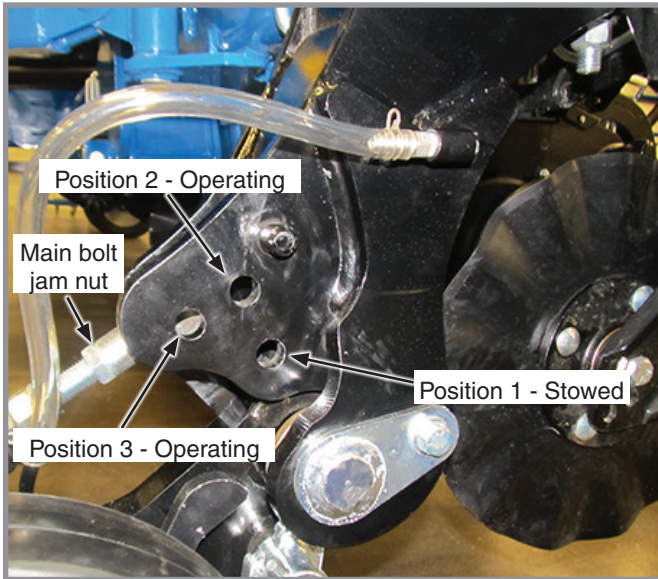

Down Force Settings			
	9" (23 cm)	8.5" (21 cm)	8" (20 cm)
Position 1 (Stowed)	N/A	N/A	N/A
Position 2 (Softer Soil Conditions)	110 - 160 lbs	150 - 210 lbs	200 - 250 lbs
Position 3 (Harder Soil Conditions)	180 - 240 lbs	250 - 285 lbs	290 - 350 lbs

The spring has been factory pre-set at 8.5" (21 cm) but can be adjusted from 8" - 9" (20 - 23 cm) as desired to fit soil conditions.

Position 2 is ideal for conventional tillage and softer soil conditions. Position 3 is used for no-till and harder soil conditions. Refer to the chart above to adjust for specific conditions.

In positions 1 and 2, coulter height can be further adjusted manually if needed by loosening the main bolt jam nut and the main bolt, up to 10 turns or 1" (2.5 cm) length.

NOTE: Approximately ¼" of bolt length adjustment provides nearly 1" (2.5 cm) of coulter height change.

NOTE: Maximum disc blade depth is 4" (10 cm).

KNIFE ADJUSTMENT



Compressed spring may fly out of this assembly if attempting to disassemble and cause injury. Do not take apart this assembly.

Disc blades are sharp and can cut causing serious injury. Wear gloves when working on or turning disc blades by hand.



Never strike knife with heavy object. Damage to knife will occur.

If knife to disc blade clearance is too large, soil or residue can wedge between knife and blade, and blade will not turn.

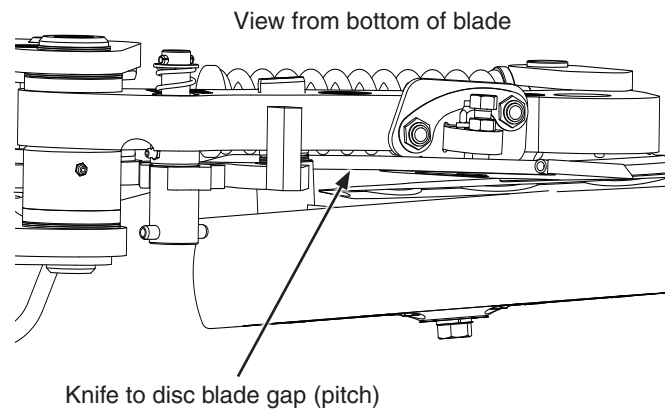
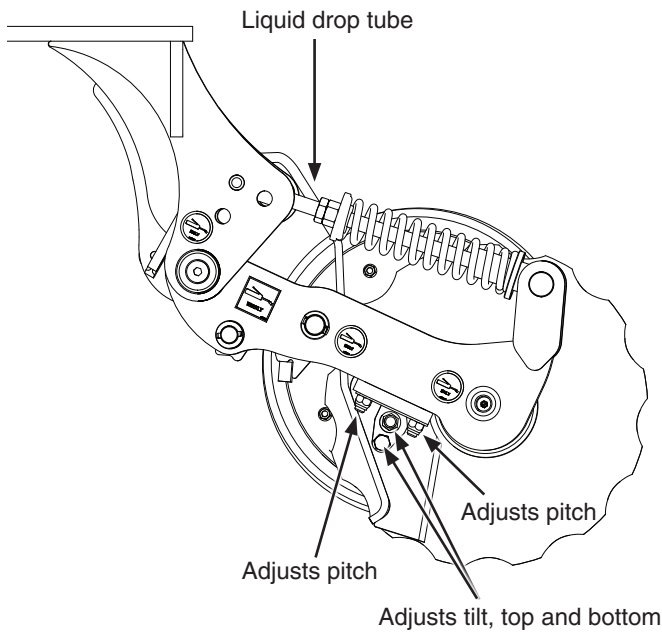

Check knife to disc blade clearance and adjust if necessary as described below.

Knife must be adjusted such that the leading edge is tight to the disc blade to keep soil and residue from wedging between them. Knife pitch is also critical to performance. Knife to disc blade gap has been factory preset at $\frac{3}{8}$ ", measured at top rear of knife. Refer to right side illustration above.



Loosen or tighten $\frac{1}{2}$ " mounting hardware to adjust knife's entire leading edge to be tight against disc blade from top to bottom. Refer to left side illustration above. Turn disc blade and check for slight drag without freewheeling. Readjust knife tension to accommodate blade high-spots as needed.

Refer to right side illustration above. If knife pitch is such that the gap is less than $\frac{3}{8}$ " (measured at top rear of knife), residue and soil may wedge between knife and disc blade, causing resistance to disc blade rotation. If knife is pitched such that the gap exceeds $\frac{3}{8}$ " (measured at top rear), accelerated knife/drop tube wear will result.

NOTICE

After knife adjustment, adjust top end of liquid drop tube accordingly to ensure adequate clearance to opener mount and gauge wheel through the entire range of motion for the openers.

LIQUID FERTILIZER ATTACHMENT

 WARNING	<p>Agricultural chemicals can cause death or serious injury to persons, animals, and plants or seriously damage soil, equipment, or property. Read and follow all chemical and equipment manufacturers labels and instructions.</p>
	

 CAUTION	<p>Overfilling tank can cause siphoning, tank collapse, personal injury, and damage to property and equipment. Do not overfill tank. Do not leave planter unattended when filling tank. Close fill valve and open tank lid if siphoning occurs. Follow all chemical manufacturers first aid, cleanup, and handling instructions.</p>
--	--

NOTICE	<p>Placing fertilizer too close to seeds or in excessive amounts can cause germination or seedling damage. Check with your fertilizer dealer or manufacturer for correct amount and placement.</p>
---------------	--



Liquid fertilizer installed on 4900 bulk fill

CHECK VALVES



Low rate check valves are provided for in-line installation between liquid fertilizer piston pump and openers or in-furrow to ensure equal distribution of product at low rates and siphon protection for field turns. Check valves eliminate the need for anti-siphon loops.

REAR TRAILER HITCH OPTION



Trailer Hitch

Rear trailer hitch is used to tow a 3 or 4 wheel wagon behind planter. Hitch height during field operation and transport is 15". Hitch height will raise to approximately 42" when planter is lifted.

NOTICE

Rear trailer hitch is designed for use with piston pump only. Maximum allowable hitch weight is 200 lb (90.71 kg). Do not exceed 6,000 lb (2,721.55 kg) gross towing weight or the equivalent of a loaded 500 gal (1,892.7 L) tank and running gear or equipment can be damaged.

NOTE: Periodically check feed hose for kinks to prevent restricted delivery rate.

Adjust rear trailer hitch length by loosening the $\frac{5}{8}$ " set screws at rear of outer tube, removing 1" x 8 $\frac{1}{2}$ " bolt at center of hitch, and sliding hitch in or out to one of 4 sets of adjustment holes. Reinstall and tighten hardware.

This page left blank intentionally.

GENERAL PLANTING RATE INFORMATION

These planting rate charts apply to KINZE Model 4900 planters.

NOTICE

Sprocket combinations in these charts are for average conditions. Changes in sprocket combinations may be required for desired planting population. **ALWAYS MAKE FIELD CHECKS TO BE SURE YOU ARE PLANTING AT THE DESIRED RATE.**

NOTICE

Seed additives added in the hopper may affect finger pickup seed meter performance and accelerate wear.

NOTE: Seed size and shape may affect planting rate.

NOTE: Not all row spacings listed apply to all size planters.

NOTE: Speeds above 6.5 MPH (10.5 KPH) can adversely affect seed spacing.

MECHANICAL

Finger Pickup Corn Meter

Larger grades generally plant more accurately at the high end of the ground speed range than smaller grades. Higher than optimum speeds may result in population rate increase or higher incidence of doubles, particularly with small seed. Medium round corn seed is most desirable for planting accuracy at optimum speed.

Finger Pickup Oil Sunflower Meter

Larger grades generally plant more accurately at the high end of the ground speed range than smaller grades. Higher than optimum speeds may result in population rate increase or higher incidence of doubles, particularly with small seed. No. 3 and/or No. 4 size oil sunflower seeds are recommended for use in finger pickup seed meters equipped with oil sunflower fingers. No. 1 and/or No. 2 size confectionery sunflower seeds are recommended for use in finger pickup seed meters equipped with corn fingers.

Brush-Type Seed Meter (Soybean, Milo/Grain Sorghum, Acid-Delinted Cotton)

Rate charts are given in seeds per acre as well as seed spacing in inches rounded to nearest tenth of an inch. Because of large range in seed size, pounds per acre is not a suggested method of selecting transmission settings. Smaller size seed pounds per acre may be below what was expected and large seed pounds per acre may appear above expectations. To determine pounds per acre, use formula given in "Determining Pounds Per Acre (Brush-Type Seed Meter)" in "Check Seed Population" in Machine Operation section of this manual.

NOTE: Planting speed can affect actual seeding rate. Make a field check and adjust transmission setting to obtain desired seed drop.

VACUUM

NOTE: 15, 22, and 28 tooth drive sprockets are NOT applicable to all rate charts. Check chart titles to ensure proper rate chart is selected. 22 tooth sprockets require use of 148 pitch No. 40 chains, 28 tooth sprockets require use of 150 pitch No. 40 chains.

**PLANTING RATES FOR FINGER PICKUP SEED METER (28 TOOTH CONTACT DRIVE)
APPROXIMATE SEEDS/ACRE FOR 30" ROW WIDTH**

30" Rows	Transmission Sprockets		Recommended Speed Range (MPH)	Average Seed Spacing In Inches
	Drive	Driven		
13,330	15	28	4 to 6	15.7
13,824	15	27	4 to 6	15.1
14,355	15	26	4 to 6	14.6
14,929	15	25	4 to 6	14.0
15,107	17	28	4 to 6	13.8
15,551	15	24	4 to 6	13.4
15,666	17	27	4 to 6	13.3
16,226	15	23	4 to 6	12.9
16,269	17	26	4 to 6	12.9
16,884	19	28	4 to 6	12.4
16,919	17	25	4 to 6	12.4
17,509	19	27	4 to 6	11.9
17,624	17	24	4 to 6	11.9
18,182	19	26	4 to 6	11.5
18,390	17	23	4 to 6	11.4
18,910	19	25	4 to 6	11.1
19,644	15	19	4 to 6	10.6
19,697	19	24	4 to 6	10.6
20,438	23	28	4 to 6	10.2
20,554	19	23	4 to 6	10.2
21,195	23	27	4 to 6	9.9
21,327	24	28	4 to 6	9.8
21,954	15	17	4 to 6	9.5
22,117	24	27	4 to 6	9.5
22,263	17	19	4 to 6	9.4
22,891	23	25	4 to 6	9.1
23,105	26	28	4 to 6	9.0
23,845	23	24	4 to 6	8.8
23,886	24	25	4 to 6	8.8
23,993	27	28	4 to 6	8.7
24,882	23	23	4 to 6	8.4
25,803	28	27	4 to 6	8.1
25,838	27	26	4 to 6	8.1
25,963	24	23	4 to 6	8.1
26,795	28	26	4 to 6	7.8
26,872	27	25	4 to 6	7.8
27,045	25	23	4 to 6	7.7
27,809	19	17	4 to 6	7.5
27,992	27	24	4 to 6	7.5
28,127	26	23	4 to 6	7.4
29,029	28	24	4 to 6	7.2
29,209	27	23	4 to 6	7.2
30,120	23	19	4 to 6	6.9
30,290	28	23	4 to 6	6.9
31,429	24	19	4 to 6	6.7
32,739	25	19	4 to 6	6.4
33,663	23	17	4 to 6	6.2
34,048	26	19	4 to 6	6.1
35,127	24	17	4 to 6	6.0
35,357	27	19	4 to 6	5.9
36,590	25	17	4 to 6	5.7
36,668	28	19	4 to 6	5.7
38,054	26	17	4 to 6	5.5
38,151	23	15	4 to 6	5.5
39,517	27	17	4 to 6	5.3

NOTE: See "General Planting Rate Information" and "Check Seed Population" pages for more information. Always field check seed population to verify planting rates.

**PLANTING RATES FOR BRUSH-TYPE SEED METERS (28 TOOTH CONTACT DRIVE)
APPROXIMATE SEEDS/ACRE FOR 30" ROW WIDTH**

Transmission Sprockets		60 Cell Soybean Or High-Rate Milo/Grain Sorghum 30" Rows	Average Seed Spacing In Inches	48 Cell Specialty Soybean Or High-Rate Acid-Delinted Cotton 30" Rows	Average Seed Spacing In Inches	Speed Range (MPH)
Drive	Driven					
15	28	66,646.53	3.1	53,317	3.9	4 to 6
15	27	69,115.20	3.0	55,292	3.8	4 to 6
15	26	71,773.33	2.9	57,419	3.6	4 to 6
15	25	74,644.27	2.8	59,715	3.5	4 to 6
17	28	75,532.80	2.8	60,426	3.5	4 to 6
15	24	77,754.13	2.7	62,203	3.4	4 to 6
17	27	78,330.93	2.7	62,665	3.3	4 to 6
15	23	81,135.60	2.6	64,908	3.2	4 to 6
17	26	81,343.73	2.6	65,075	3.2	4 to 6
19	28	84,419.07	2.5	67,535	3.1	4 to 6
17	25	84,596.40	2.5	67,677	3.1	4 to 6
19	27	87,545.73	2.4	70,037	3.0	4 to 6
17	24	88,121.60	2.4	70,497	3.0	4 to 6
19	26	90,913.20	2.3	72,731	2.9	4 to 6
17	23	91,952.93	2.3	73,562	2.8	4 to 6
19	25	94,549.47	2.2	75,640	2.8	4 to 6
15	19	98,216.53	2.1	78,573	2.7	4 to 6
19	24	98,489.07	2.1	78,791	2.7	4 to 6
23	28	102,191.60	2.0	81,753	2.6	4 to 6
19	23	102,771.20	2.0	82,217	2.5	4 to 6
23	27	105,976.27	2.0	84,781	2.5	4 to 6
24	28	106,635.20	2.0	85,308	2.5	4 to 6
15	17	109,771.20	1.9	87,817	2.4	4 to 6
24	27	110,584.13	1.9	88,467	2.4	4 to 6
17	19	111,312.13	1.9	89,050	2.3	4 to 6
23	25	114,454.67	1.8	91,564	2.3	4 to 6
26	28	115,521.47	1.8	92,417	2.3	4 to 6
23	24	119,224.00	1.8	95,379	2.2	4 to 6
24	25	119,431.20	1.8	95,545	2.2	4 to 6
27	28	119,964.13	1.7	95,971	2.2	4 to 6
23	23	124,407.73	1.7	99,526	2.1	4 to 6
28	27	129,015.60	1.6	103,212	2.0	4 to 6
27	26	129,192.00	1.6	103,354	2.0	4 to 6
24	23	129,816.40	1.6	103,853	2.0	4 to 6
28	26	133,977.20	1.6	107,182	2.0	4 to 6
27	25	134,359.87	1.6	107,488	1.9	4 to 6
25	23	135,225.07	1.5	108,180	1.9	4 to 6
19	17	139,043.33	1.5	111,235	1.9	4 to 6
27	24	139,958.00	1.5	111,966	1.9	4 to 6
26	23	140,633.73	1.5	112,507	1.9	4 to 6
28	24	145,141.73	1.4	116,113	1.8	4 to 6
27	23	146,043.33	1.4	116,835	1.8	4 to 6
23	19	150,598.00	1.4	120,478	1.7	4 to 6
28	23	151,452.00	1.4	121,162	1.7	4 to 6
24	19	157,146.27	1.3	125,717	1.7	4 to 6
25	19	163,693.60	1.3	130,955	1.6	4 to 6
23	17	168,315.47	1.2	134,652	1.6	4 to 6
26	19	170,241.87	1.2	136,193	1.5	4 to 6
24	17	175,633.73	1.2	140,507	1.5	4 to 6
27	19	176,789.20	1.2	141,431	1.5	4 to 6
25	17	182,952.00	1.1	146,362	1.4	4 to 6
28	19	183,337.47	1.1	146,670	1.4	4 to 6
26	17	190,270.27	1.1	152,216	1.4	4 to 6
23	15	190,757.47	1.1	152,606	1.4	4 to 6
27	17	197,588.53	1.1	158,071	1.3	4 to 6

NOTE: See "General Planting Rate Information" and "Check Seed Population" pages for more information. Always field check seed population to verify planting rates.

**PLANTING RATE FOR BRUSH-TYPE SEED METERS (28 TOOTH CONTACT DRIVE)
APPROXIMATE SEEDS/ACRE FOR 30" ROW WIDTH**

Transmission Sprockets		36 Cell Acid-Delinted Large Cotton 30" Rows	Average Seed Spacing In Inches	30 Cell Milo/Grain Sorghum Or Acid-Delinted Cotton 30" Rows	Average Seed Spacing In Inches	Speed Range (MPH)
Drive	Driven					
15	28	39,988	5.2	33,323	6.3	4 to 6
15	27	41,469	5.0	34,558	6.1	4 to 6
15	26	43,064	4.9	35,887	5.8	4 to 6
15	25	44,787	4.7	37,322	5.6	4 to 6
17	28	45,320	4.6	37,766	5.5	4 to 6
15	24	46,652	4.5	38,877	5.4	4 to 6
17	27	46,999	4.4	39,165	5.3	4 to 6
15	23	48,681	4.3	40,568	5.2	4 to 6
17	26	48,806	4.3	40,672	5.1	4 to 6
19	28	50,651	4.1	42,210	5.0	4 to 6
17	25	50,758	4.1	42,298	4.9	4 to 6
19	27	52,527	4.0	43,773	4.8	4 to 6
17	24	52,873	4.0	44,061	4.7	4 to 6
19	26	54,548	3.8	45,457	4.6	4 to 6
17	23	55,172	3.8	45,976	4.5	4 to 6
19	25	56,730	3.7	47,275	4.4	4 to 6
15	19	58,930	3.5	49,108	4.3	4 to 6
19	24	59,093	3.5	49,245	4.2	4 to 6
23	28	61,315	3.4	51,096	4.1	4 to 6
19	23	61,663	3.4	51,386	4.1	4 to 6
23	27	63,586	3.3	52,988	3.9	4 to 6
24	28	63,981	3.3	53,318	3.9	4 to 6
15	17	65,863	3.2	54,886	3.8	4 to 6
24	27	66,350	3.2	55,292	3.8	4 to 6
17	19	66,787	3.1	55,656	3.8	4 to 6
23	25	68,673	3.0	57,227	3.7	4 to 6
26	28	69,313	3.0	57,761	3.6	4 to 6
23	24	71,534	2.9	59,612	3.5	4 to 6
24	25	71,659	2.9	59,716	3.5	4 to 6
27	28	71,978	2.9	59,982	3.5	4 to 6
23	23	74,645	2.8	62,204	3.4	4 to 6
28	27	77,409	2.7	64,508	3.2	4 to 6
27	26	77,515	2.7	64,596	3.2	4 to 6
24	23	77,890	2.7	64,908	3.2	4 to 6
28	26	80,386	2.6	66,989	3.1	4 to 6
27	25	80,616	2.6	67,180	3.1	4 to 6
25	23	81,135	2.6	67,613	3.1	4 to 6
19	17	83,426	2.5	69,522	3.0	4 to 6
27	24	83,975	2.5	69,979	3.0	4 to 6
26	23	84,380	2.5	70,317	3.0	4 to 6
28	24	87,085	2.4	72,571	2.9	4 to 6
27	23	87,626	2.4	73,022	2.9	4 to 6
23	19	90,359	2.3	75,299	2.8	4 to 6
28	23	90,871	2.3	75,726	2.8	4 to 6
24	19	94,288	2.2	78,573	2.7	4 to 6
25	19	98,216	2.1	81,847	2.6	4 to 6
23	17	100,989	2.1	84,158	2.5	4 to 6
26	19	102,145	2.0	85,121	2.5	4 to 6
24	17	105,380	2.0	87,817	2.4	4 to 6
27	19	106,074	2.0	88,395	2.4	4 to 6
25	17	109,771	1.9	91,476	2.3	4 to 6
28	19	110,002	1.9	91,669	2.3	4 to 6
26	17	114,162	1.8	95,135	2.2	4 to 6
23	15	114,454	1.8	95,379	2.2	4 to 6
27	17	118,553	1.8	98,794	2.1	4 to 6

NOTE: See "General Planting Rate Information" and "Check Seed Population" pages for more information. Always field check seed population to verify planting rates.

**PLANTING RATES FOR BRUSH-TYPE SEED METERS (28 TOOTH CONTACT DRIVE)
APPROXIMATE HILLS/ACRE FOR 30" ROW WIDTH**

Due to variations in cotton seed size, meters equipped with the 12 cell acid-delinted hill-drop cotton discs will plant from 3 to 6 seeds per cell. Select proper disc for seed size range to be planted.

To determine planter transmission setting, determine desired hill spacing and select the transmission ratio closest to the hill spacing in inches on the chart. To decrease population increase spacing. To increase population decrease spacing.

To determine population per acre, determine average seeds per hill and hills per acre by doing a field check. Measure $\frac{1}{1000}$ of an acre ($\frac{1}{1000}$ acre = Length of row 17' 5" for 30" row width). Multiply average seeds per hill by hills per acre. EXAMPLE: 4 seeds per hill x (13 hills x 1000) = 52,000

Transmission Sprockets		NUMBER OF HILLS PER ACRE 12 Cell Hill-Drop Cotton, Acid-Delinted 30" Rows	Average Hill Spacing In Inches	Speed Range (MPH)
Drive	Driven			
15	28	13,329	15.7	4 to 6
15	27	13,823	15.1	4 to 6
15	26	14,355	14.6	4 to 6
15	25	14,929	14.0	4 to 6
17	28	15,107	13.8	4 to 6
15	24	15,551	13.4	4 to 6
17	27	15,666	13.3	4 to 6
15	23	16,227	12.9	4 to 6
17	26	16,269	12.9	4 to 6
19	28	16,884	12.4	4 to 6
17	25	16,919	12.4	4 to 6
19	27	17,509	11.9	4 to 6
17	24	17,624	11.9	4 to 6
19	26	18,183	11.5	4 to 6
17	23	18,391	11.4	4 to 6
19	25	18,910	11.1	4 to 6
15	19	19,643	10.6	4 to 6
19	24	19,698	10.6	4 to 6
23	28	20,438	10.2	4 to 6
19	23	20,554	10.2	4 to 6
23	27	21,195	9.9	4 to 6
24	28	21,327	9.8	4 to 6
15	17	21,954	9.5	4 to 6
24	27	22,117	9.5	4 to 6
17	19	22,262	9.4	4 to 6
23	25	22,891	9.1	4 to 6
26	28	23,104	9.0	4 to 6
23	24	23,845	8.8	4 to 6
24	25	23,886	8.8	4 to 6
27	28	23,993	8.7	4 to 6
23	23	24,882	8.4	4 to 6
28	27	25,803	8.1	4 to 6
27	26	25,838	8.1	4 to 6
24	23	25,963	8.1	4 to 6
28	26	26,795	7.8	4 to 6
27	25	26,872	7.8	4 to 6
25	23	27,045	7.7	4 to 6
19	17	27,809	7.5	4 to 6
27	24	27,992	7.5	4 to 6
26	23	28,127	7.4	4 to 6
28	24	29,028	7.2	4 to 6
27	23	29,209	7.2	4 to 6
23	19	30,120	6.9	4 to 6
28	23	30,290	6.9	4 to 6
24	19	31,429	6.7	4 to 6
25	19	32,739	6.4	4 to 6
23	17	33,663	6.2	4 to 6
26	19	34,048	6.1	4 to 6
24	17	35,127	6.0	4 to 6
27	19	35,358	5.9	4 to 6
25	17	36,590	5.7	4 to 6
28	19	36,667	5.7	4 to 6
26	17	38,054	5.5	4 to 6
23	15	38,151	5.5	4 to 6
27	17	39,518	5.3	4 to 6

NOTE: See "General Planting Rate Information" and "Check Seed Population" pages for more information. Always field check seed population to verify planting rates.

**PLANTING RATES FOR (VACUUM) CORN/POPCORN/SUNFLOWER 40 CELL DISC
15 TOOTH CONTACT WHEEL DRIVE**

30" Rows	Transmission Sprockets		Recomm. Speed (MPH)	Average Spacing In Inches
	Drive	Driven		
16,230	15	28	4 to 6	12.9
16,831	15	27	4 to 6	12.4
17,478	15	26	4 to 6	12.0
18,178	15	25	4 to 6	11.5
18,394	17	28	4 to 6	11.4
18,935	15	24	4 to 6	11.0
19,075	17	27	4 to 6	11.0
19,758	15	23	4 to 6	10.6
19,808	17	26	4 to 6	10.6
20,558	19	28	4 to 6	10.2
20,601	17	25	4 to 6	10.1
21,319	19	27	4 to 6	9.8
21,459	17	24	4 to 6	9.7
22,139	19	26	4 to 6	9.4
22,392	17	23	4 to 6	9.3
23,024	19	25	4 to 6	9.1
23,917	15	19	4 to 6	8.7
23,984	19	24	4 to 6	8.7
24,886	23	28	4 to 6	8.4
25,027	19	23	4 to 6	8.4
25,808	23	27	4 to 6	8.1
25,968	24	28	4 to 6	8.1
26,731	15	17	4 to 6	7.8
26,929	24	27	4 to 6	7.8
27,107	17	19	4 to 6	7.7
27,872	23	25	4 to 6	7.5
28,131	26	28	4 to 6	7.4
29,034	23	24	4 to 6	7.2
29,084	24	25	4 to 6	7.2
29,214	27	28	4 to 6	7.2
30,296	23	23	4 to 6	6.9
31,417	28	27	4 to 6	6.7
31,461	27	26	4 to 6	6.6
31,613	24	23	4 to 6	6.6
32,626	28	26	4 to 6	6.4
32,720	27	25	4 to 6	6.4
32,930	25	23	4 to 6	6.3
33,860	19	17	4 to 6	6.2
34,083	27	24	4 to 6	6.1
34,248	26	23	4 to 6	6.1
35,345	28	24	4 to 6	5.9
35,564	27	23	4 to 6	5.9
36,673	23	19	4 to 6	5.7
36,882	28	23	4 to 6	5.7
38,269	24	19	4 to 6	5.5
39,863	25	19	4 to 6	5.2
40,988	23	17	4 to 6	5.1
41,457	26	19	4 to 6	5.0
42,771	24	17	4 to 6	4.9
43,052	27	19	4 to 6	4.9
44,552	25	17	4 to 6	4.7
44,646	28	19	4 to 6	4.7
46,334	26	17	4 to 6	4.5
46,453	23	15	4 to 6	4.5
48,117	27	17	4 to 6	4.3

NOTE: See "General Planting Rate Information" and "Check Seed Population" pages for more information. Always field

**PLANTING RATES FOR (VACUUM) CORN/POPCORN/SUNFLOWER 40 CELL DISC
22 TOOTH CONTACT WHEEL DRIVE**

30" Rows	Transmission Sprockets		Recomm. Speed (MPH)	Average Spacing In Inches
	Drive	Driven		
23,804	15	28	4 to 6	8.8
24,685	15	27	4 to 6	8.5
25,635	15	26	4 to 6	8.2
26,661	15	25	4 to 6	7.8
26,977	17	28	4 to 6	7.8
27,771	15	24	4 to 6	7.5
27,976	17	27	4 to 6	7.5
28,978	15	23	4 to 6	7.2
29,052	17	26	4 to 6	7.2
30,152	19	28	4 to 6	6.9
30,215	17	25	4 to 6	6.9
31,268	19	27	4 to 6	6.7
31,474	17	24	4 to 6	6.6
32,471	19	26	4 to 6	6.4
32,842	17	23	4 to 6	6.4
33,769	19	25	4 to 6	6.2
35,079	15	19	4 to 6	6.0
35,176	19	24	4 to 6	5.9
36,499	23	28	4 to 6	5.7
36,706	19	23	4 to 6	5.7
37,851	23	27	4 to 6	5.5
38,086	24	28	4 to 6	5.5
39,206	15	17	4 to 6	5.3
39,496	24	27	4 to 6	5.3
39,757	17	19	4 to 6	5.3
40,879	23	25	4 to 6	5.1
41,259	26	28	4 to 6	5.1
42,583	23	24	4 to 6	4.9
42,656	24	25	4 to 6	4.9
42,847	27	28	4 to 6	4.9
44,434	23	23	4 to 6	4.7
46,079	28	27	4 to 6	4.5
46,143	27	26	4 to 6	4.5
46,365	24	23	4 to 6	4.5
47,851	28	26	4 to 6	4.4
47,989	27	25	4 to 6	4.4
48,297	25	23	4 to 6	4.3
49,662	19	17	4 to 6	4.2
49,988	27	24	4 to 6	4.2
50,230	26	23	4 to 6	4.2
51,839	28	24	4 to 6	4.0
52,161	27	23	4 to 6	4.0
53,788	23	19	4 to 6	3.9
54,093	28	23	4 to 6	3.9
56,127	24	19	4 to 6	3.7
58,466	25	19	4 to 6	3.6
60,116	23	17	4 to 6	3.5
60,804	26	19	4 to 6	3.4
62,730	24	17	4 to 6	3.3
63,143	27	19	4 to 6	3.3
65,344	25	17	4 to 6	3.2
65,481	28	19	4 to 6	3.2
67,957	26	17	4 to 6	3.1
68,131	23	15	4 to 6	3.1
70,571	27	17	4 to 6	3.0

NOTE: See "General Planting Rate Information" and "Check Seed Population" pages for more information. Always field

**PLANTING RATES FOR (VACUUM) CORN/POPCORN/SUNFLOWER 40 CELL DISC
28 TOOTH CONTACT WHEEL DRIVE**

30" Rows	Transmission Sprockets		Recomm. Speed (MPH)	Average Spacing In Inches
	Drive	Driven		
30,295	15	28	4 to 6	6.9
31,417	15	27	4 to 6	6.7
32,626	15	26	4 to 6	6.4
33,931	15	25	4 to 6	6.2
34,335	17	28	4 to 6	6.1
35,345	15	24	4 to 6	5.9
35,607	17	27	4 to 6	5.9
36,882	15	23	4 to 6	5.7
36,976	17	26	4 to 6	5.7
38,374	19	28	4 to 6	5.4
38,455	17	25	4 to 6	5.4
39,796	19	27	4 to 6	5.3
40,057	17	24	4 to 6	5.2
41,326	19	26	4 to 6	5.1
41,799	17	23	4 to 6	5.0
42,979	19	25	4 to 6	4.9
44,646	15	19	4 to 6	4.7
44,770	19	24	4 to 6	4.7
46,453	23	28	4 to 6	4.5
46,717	19	23	4 to 6	4.5
48,174	23	27	4 to 6	4.3
48,473	24	28	4 to 6	4.3
49,898	15	17	4 to 6	4.2
50,269	24	27	4 to 6	4.2
50,599	17	19	4 to 6	4.1
52,028	23	25	4 to 6	4.0
52,513	26	28	4 to 6	4.0
54,196	23	24	4 to 6	3.9
54,290	24	25	4 to 6	3.9
54,532	27	28	4 to 6	3.8
56,552	23	23	4 to 6	3.7
58,646	28	27	4 to 6	3.6
58,727	27	26	4 to 6	3.6
59,010	24	23	4 to 6	3.5
60,903	28	26	4 to 6	3.4
61,076	27	25	4 to 6	3.4
61,470	25	23	4 to 6	3.4
63,205	19	17	4 to 6	3.3
63,621	27	24	4 to 6	3.3
63,928	26	23	4 to 6	3.3
65,977	28	24	4 to 6	3.2
66,387	27	23	4 to 6	3.1
68,457	23	19	4 to 6	3.1
68,846	28	23	4 to 6	3.0
71,434	24	19	4 to 6	2.9
74,410	25	19	4 to 6	2.8
76,512	23	17	4 to 6	2.7
77,387	26	19	4 to 6	2.7
79,838	24	17	4 to 6	2.6
80,363	27	19	4 to 6	2.6
83,165	25	17	4 to 6	2.5
83,339	28	19	4 to 6	2.5
86,491	26	17	4 to 6	2.4
86,713	23	15	4 to 6	2.4
89,817	27	17	4 to 6	2.3

**PLANTING RATES FOR (VACUUM) MILO/SUGAR BEET/SPECIALTY 60 CELL DISCS
22 TOOTH CONTACT WHEEL DRIVE**

30" Rows	Transmission Sprockets		Recomm. Speed (MPH)	Average Spacing In Inches
	Drive	Driven		
35,706	15	28	4 to 6	5.9
37,028	15	27	4 to 6	5.6
38,452	15	26	4 to 6	5.4
39,990	15	25	4 to 6	5.2
40,466	17	28	4 to 6	5.2
41,657	15	24	4 to 6	5.0
41,965	17	27	4 to 6	5.0
43,468	15	23	4 to 6	4.8
43,579	17	26	4 to 6	4.8
45,227	19	28	4 to 6	4.6
45,322	17	25	4 to 6	4.6
46,902	19	27	4 to 6	4.5
47,211	17	24	4 to 6	4.4
48,706	19	26	4 to 6	4.3
49,263	17	23	4 to 6	4.2
50,654	19	25	4 to 6	4.1
52,619	15	19	4 to 6	4.0
52,765	19	24	4 to 6	4.0
54,749	23	28	4 to 6	3.8
55,059	19	23	4 to 6	3.8
56,776	23	27	4 to 6	3.7
57,129	24	28	4 to 6	3.7
58,809	15	17	4 to 6	3.6
59,245	24	27	4 to 6	3.5
59,635	17	19	4 to 6	3.5
61,318	23	25	4 to 6	3.4
61,890	26	28	4 to 6	3.4
63,873	23	24	4 to 6	3.3
63,985	24	25	4 to 6	3.3
64,270	27	28	4 to 6	3.3
66,651	23	23	4 to 6	3.1
69,119	28	27	4 to 6	3.0
69,214	27	26	4 to 6	3.0
69,548	24	23	4 to 6	3.0
71,778	28	26	4 to 6	2.9
71,983	27	25	4 to 6	2.9
72,446	25	23	4 to 6	2.9
74,492	19	17	4 to 6	2.8
74,982	27	24	4 to 6	2.8
75,344	26	23	4 to 6	2.8
77,759	28	24	4 to 6	2.7
78,242	27	23	4 to 6	2.7
80,682	23	19	4 to 6	2.6
81,140	28	23	4 to 6	2.6
84,190	24	19	4 to 6	2.5
87,698	25	19	4 to 6	2.4
90,174	23	17	4 to 6	2.3
91,206	26	19	4 to 6	2.3
94,095	24	17	4 to 6	2.2
94,714	27	19	4 to 6	2.2
98,015	25	17	4 to 6	2.1
98,222	28	19	4 to 6	2.1
101,936	26	17	4 to 6	2.1
102,197	23	15	4 to 6	2.0
105,857	27	17	4 to 6	2.0

**PLANTING RATES FOR (VACUUM) MILO/SUGAR BEET/SPECIALTY 60 CELL DISCS
28 TOOTH CONTACT WHEEL DRIVE**

30" Rows	Transmission Sprockets		Recomm. Speed (MPH)	Average Spacing In Inches
	Drive	Driven		
45,444.00	15	28	4 to 6	4.6
47,127.00	15	27	4 to 6	4.4
48,939.00	15	26	4 to 6	4.3
50,897.00	15	25	4 to 6	4.1
51,503.00	17	28	4 to 6	4.1
53,017.00	15	24	4 to 6	3.9
53,410.00	17	27	4 to 6	3.9
55,323.00	15	23	4 to 6	3.8
55,464.00	17	26	4 to 6	3.8
57,562.00	19	28	4 to 6	3.6
57,683.00	17	25	4 to 6	3.6
59,694.00	19	27	4 to 6	3.5
60,086.00	17	24	4 to 6	3.5
61,990.00	19	26	4 to 6	3.4
62,699.00	17	23	4 to 6	3.3
64,469.00	19	25	4 to 6	3.2
66,969.00	15	19	4 to 6	3.1
67,155.00	19	24	4 to 6	3.1
69,680.00	23	28	4 to 6	3.0
70,075.00	19	23	4 to 6	3.0
72,261.00	23	27	4 to 6	2.9
72,710.00	24	28	4 to 6	2.9
74,848.00	15	17	4 to 6	2.8
75,403.00	24	27	4 to 6	2.8
75,899.00	17	19	4 to 6	2.8
78,042.00	23	25	4 to 6	2.7
78,769.00	26	28	4 to 6	2.7
81,293.00	23	24	4 to 6	2.6
81,435.00	24	25	4 to 6	2.6
81,798.00	27	28	4 to 6	2.6
84,828.00	23	23	4 to 6	2.5
87,970.00	28	27	4 to 6	2.4
88,091.00	27	26	4 to 6	2.4
88,516.00	24	23	4 to 6	2.4
91,353.00	28	26	4 to 6	2.3
91,614.00	27	25	4 to 6	2.3
92,204.00	25	23	4 to 6	2.3
94,808.00	19	17	4 to 6	2.2
95,431.00	27	24	4 to 6	2.2
95,892.00	26	23	4 to 6	2.2
98,966.00	28	24	4 to 6	2.1
99,581.00	27	23	4 to 6	2.1
102,686.00	23	19	4 to 6	2.0
103,269.00	28	23	4 to 6	2.0
107,151.00	24	19	4 to 6	2.0
111,616.00	25	19	4 to 6	1.9
114,767.00	23	17	4 to 6	1.8
116,080.00	26	19	4 to 6	1.8
119,757.00	24	17	4 to 6	1.7
120,545.00	27	19	4 to 6	1.7
124,747.00	25	17	4 to 6	1.7
125,010.00	28	19	4 to 6	1.7
129,737.00	26	17	4 to 6	1.6
130,070.00	23	15	4 to 6	1.6
134,727.00	27	17	4 to 6	1.6

**PLANTING RATES FOR (VACUUM) SOYBEAN 120 CELL DISC
22 TOOTH CONTACT WHEEL DRIVE APPROXIMATE SEEDS/ACRE FOR VARIOUS
ROW WIDTHS**

30" Rows	Transmission Sprockets		Recomm. Speed (MPH)	Average Spacing In Inches
	Drive	Driven		
71,411	15	28	4 to 6	2.9
74,056	15	27	4 to 6	2.8
76,904	15	26	4 to 6	2.7
79,981	15	25	4 to 6	2.6
80,933	17	28	4 to 6	2.6
83,313	15	24	4 to 6	2.5
83,930	17	27	4 to 6	2.5
86,935	15	23	4 to 6	2.4
87,158	17	26	4 to 6	2.4
90,454	19	28	4 to 6	2.3
90,645	17	25	4 to 6	2.3
93,804	19	27	4 to 6	2.2
94,422	17	24	4 to 6	2.2
97,412	19	26	4 to 6	2.1
98,527	17	23	4 to 6	2.1
101,309	19	25	4 to 6	2.1
105,238	15	19	4 to 6	2.0
105,530	19	24	4 to 6	2.0
109,497	23	28	4 to 6	1.9
110,118	19	23	4 to 6	1.9
113,553	23	27	4 to 6	1.8
114,258	24	28	4 to 6	1.8
117,619	15	17	4 to 6	1.8
118,490	24	27	4 to 6	1.8
119,269	17	19	4 to 6	1.8
122,687	23	25	4 to 6	1.7
123,780	26	28	4 to 6	1.7
127,747	23	24	4 to 6	1.6
127,969	24	25	4 to 6	1.6
128,540	27	28	4 to 6	1.6
133,301	23	23	4 to 6	1.6
138,238	28	27	4 to 6	1.5
138,428	27	26	4 to 6	1.5
139,097	24	23	4 to 6	1.5
143,555	28	26	4 to 6	1.5
143,965	27	25	4 to 6	1.5
144,892	25	23	4 to 6	1.4
148,984	19	17	4 to 6	1.4
149,964	27	24	4 to 6	1.4
150,688	26	23	4 to 6	1.4
155,518	28	24	4 to 6	1.3
156,484	27	23	4 to 6	1.3
161,364	23	19	4 to 6	1.3
162,280	28	23	4 to 6	1.3
168,380	24	19	4 to 6	1.2
175,396	25	19	4 to 6	1.2
180,349	23	17	4 to 6	1.2
182,412	26	19	4 to 6	1.1
188,190	24	17	4 to 6	1.1
189,428	27	19	4 to 6	1.1
196,031	25	17	4 to 6	1.1
196,444	28	19	4 to 6	1.1
203,872	26	17	4 to 6	1.0
204,395	23	15	4 to 6	1.0
211,713	27	17	4 to 6	1.0

**PLANTING RATES FOR (VACUUM) SOYBEAN 120 CELL DISC
28 TOOTH CONTACT WHEEL DRIVE APPROXIMATE SEEDS/ACRE FOR VARIOUS
ROW WIDTHS**

30" Rows	Transmission Sprockets		Recomm. Speed (MPH)	Average Spacing In Inches
	Drive	Driven		
90,887	15	28	4 to 6	2.3
94,887	15	27	4 to 6	2.2
97,878	15	26	4 to 6	2.1
101,794	15	25	4 to 6	2.1
103,005	17	28	4 to 6	2.0
106,035	15	24	4 to 6	2.0
106,820	17	27	4 to 6	2.0
110,645	15	23	4 to 6	1.9
110,929	17	26	4 to 6	1.9
115,124	19	28	4 to 6	1.8
115,366	17	25	4 to 6	1.8
119,387	19	27	4 to 6	1.8
120,387	17	24	4 to 6	1.7
120,173	19	26	4 to 6	1.7
123,979	17	23	4 to 6	1.7
125,398	19	25	4 to 6	1.7
128,938	15	19	4 to 6	1.6
133,939	19	24	4 to 6	1.6
134,311	23	28	4 to 6	1.6
139,360	19	23	4 to 6	1.5
140,151	23	27	4 to 6	1.5
144,522	24	28	4 to 6	1.4
145,419	15	17	4 to 6	1.4
149,696	24	27	4 to 6	1.4
150,805	17	19	4 to 6	1.4
151,797	23	25	4 to 6	1.4
156,083	26	28	4 to 6	1.3
157,538	23	24	4 to 6	1.3
162,587	24	25	4 to 6	1.3
162,870	27	28	4 to 6	1.3
163,597	23	23	4 to 6	1.3
169,656	28	27	4 to 6	1.2
175,939	27	26	4 to 6	1.2
176,181	24	23	4 to 6	1.2
177,032	28	26	4 to 6	1.2
182,706	27	25	4 to 6	1.1
183,228	25	23	4 to 6	1.1
184,409	19	17	4 to 6	1.1
189,615	27	24	4 to 6	1.1
190,863	26	23	4 to 6	1.1
191,785	28	24	4 to 6	1.1
197,932	27	23	4 to 6	1.1
199,161	23	19	4 to 6	1.0
205,373	28	23	4 to 6	1.0
206,538	24	19	4 to 6	1.0
214,302	25	19	4 to 6	1.0
223,231	23	17	4 to 6	0.9
229,534	26	19	4 to 6	0.9
232,161	24	17	4 to 6	0.9
239,514	27	19	4 to 6	0.9
241,090	25	17	4 to 6	0.9
249,494	28	19	4 to 6	0.8
NOTE: Planting rates over 250,000 seeds per acre are NOT recommended with this seed disc and/or drive ratio	26	17		
	23	15		
	27	17		

DRY INSECTICIDE APPLICATION RATES
APPROXIMATE POUNDS/ACRE AT 5 MPH (8 KPH)

Meter Setting	30" Rows
CLAY GRANULES	
10	4.9
11	5.4
12	6.1
13	6.9
14	7.7
15	8.5
16	9.6
17	10.7
18	11.4
19	13.1
20	14.2
21	15.5
22	16.4
23	17.2
24	18.8
25	20.9
26	23.0
27	24.1
28	25.4
29	27.8
30	29.6
SAND GRANULES	
5	2.9
6	4.9
7	5.3
8	6.3
9	7.8
10	8.9
11	10.2
12	11.2
13	12.6
14	14.1
15	15.5
16	17.5
17	19.4
18	21.8
19	24.3
20	25.7
21	27.6
22	29.6
23	32.0
24	34.4
25	36.9

NOTE: Chart represents average values and should be used only as a starting point. Granular chemical flows through meter opening at a nearly uniform rate regardless of roller speed. Your actual rate will vary depending on insecticide, planting speed, and plant population. Planting speed/ground speed has the greatest effect on application rate.

Field check your actual rate with insecticide you are using at speed and population you will be planting. See "Checking Granular Chemical Application Rate" in Machine Operation section for more information..

FERTILIZER APPLICATION RATE CHART

Model NGP-6055 Pumps With 18 Tooth Sprocket and Ground Drive (Planter equipped with two piston pumps)

Pump Setting	2	3	4	5	6	7	8	9	10
24 Row 30" (Gallons per Acre)	5.4	8.2	10.8	13.6	16.2	18.8	21.6	24.4	26.8

(Planter equipped with one piston pump)

Pump Setting	2	3	4	5	6	7	8	9	10
24 Row 30" (Gallons per Acre)	2.7	4.1	5.4	6.8	8.1	9.4	10.8	12.2	13.4
16 Row 30" (Gallons per Acre)	4.1	6.1	8.1	10.1	12.1	14.1	16.2	18.2	20.2
12 Row 30" (Gallons per Acre)	5.4	8.1	10.8	13.5	16.2	18.9	21.6	24.3	27

Check tires for correct operating pressure.

Charts calculated based on a solution weighing ten pounds per gallon.

NOTE: Fertilizer application rates can vary from weights calculated in above chart. Make field checks to be sure you are applying fertilizer at desired rate.

To check the exact number of gallons your fertilizer attachment will actually deliver on a 30" row spacing:

1. Remove hose from one fertilizer opener and insert it into a collection container secured planter frame.
2. Engage fertilizer attachment and drive forward for 174'.
3. Measure fluid ounces caught in container and multiply by 100. Divide that amount by 128. Result is gallons fertilizer delivered per acre when planting in 30" rows. To convert this delivery rate for other row widths, multiply by the following conversion factors:

20" x 1.50 22" x 1.36 38" x 0.79

4. Rinse collection container and repeat test on other rows if necessary.

NOTE: Refer to piston pump manual provided with pump for additional information.

FERTILIZER RATES - CENTRIFUGAL PUMP AND PISTON PUMP WITH MANIFOLDS

NOTE: Refer to the Fertilizer Rates table on the following page to size orifice for approximately 40 psi pressure for even fertilizer distribution.

The following table can be used to determine which orifice plates can be used to achieve the desired gallons per acre application rate for fertilizer. The GPA is calculated at 5 mph with a 30" width.

Orifice Diameter	Gallons per Acre (at 5 mph)							
	10 psi	20 psi	30 psi	40 psi	50 psi	60 psi	80 psi	100 psi
.020"	1.0	1.4	1.7	2.0	2.2	2.5	2.8	3.2
.025"	1.5	2.2	2.7	3.1	3.5	3.8	4.4	4.9
.028"	1.9	2.7	3.3	3.8	4.3	4.7	5.5	6.1
.032"	2.6	3.7	4.5	5.3	5.9	6.5	7.5	8.3
.037"	3.4	4.7	5.9	6.7	7.6	8.3	9.5	10.7
.041"	4.1	5.9	7.2	8.3	9.3	10.2	11.8	13.1
.048"	5.6	7.9	9.7	11.3	12.6	13.8	15.9	17.8
.055"	7.4	10.5	12.9	14.8	16.6	18.2	21.0	23.5
.065"	10.3	14.6	17.8	20.6	23.0	25.3	29.2	32.6

NOTE: Operating pressure while operating in the field should be 30 - 40 psi. Orifice diameter is factory installed at 0.037".

This page intentionally left blank.

NOTICE

Disconnect all electronic monitor and control modules prior to making any repairs or modifications to the planter or mounted attachments. Failure to do so will result in permanent damage to sensitive electronic components and could void your warranty.

LUBRICATION

Following pages show locations of all lubrication points. Proper lubrication of moving parts helps ensure efficient operation of your Kinze planter and prolongs the life of friction producing parts.

LUBRICATION SYMBOLS

Lubricate at frequency indicated with SAE multipurpose grease.



Lubricate at frequency indicated with high quality SAE 10 weight oil or spray lubricant.

WHEEL BEARINGS

All drive, transport, and marker hub wheel bearings should be repacked annually and checked for wear.

1. Raise wheel off ground.
2. Check for bearing endplay by moving wheel side to side.
3. Rotate wheel to check for bearing roughness. If bearings sound rough, remove hub and inspect bearings.

NOTE: To repack wheel hubs, follow procedure outlined for wheel bearing replacement in this section except bearings and bearing cups are reused.

GREASE FITTINGS

WARNING

Uncontrolled movement of equipment can cause loss of control and could result in death, serious injury, or damage to property and equipment. Install all safety lockup devices before transporting equipment.

Parts equipped with grease fittings should be lubricated at frequency indicated with an SAE multipurpose grease. Clean fitting thoroughly before using grease gun. Frequency of lubrication recommended is based on normal operating conditions. Severe or unusual conditions may require more frequent attention.

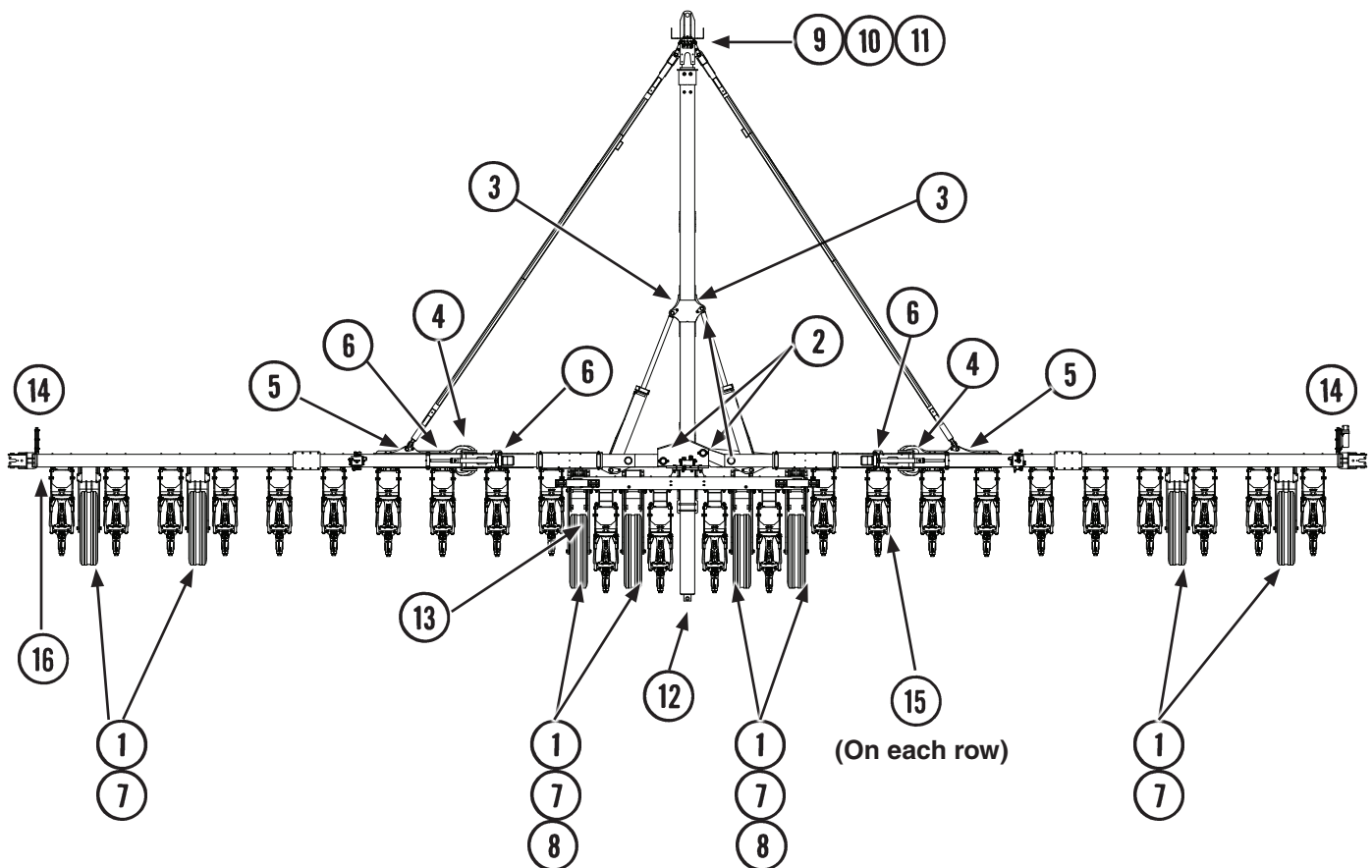

NOTE: Numbers on illustration above correspond to photos on following pages showing lubrication frequencies.

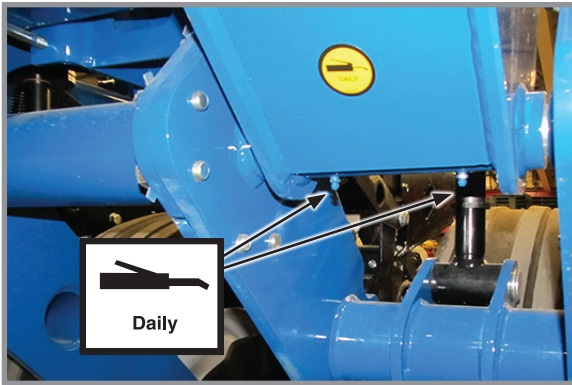

**1. Wheel modules, 8 per machine
2 fittings per module**

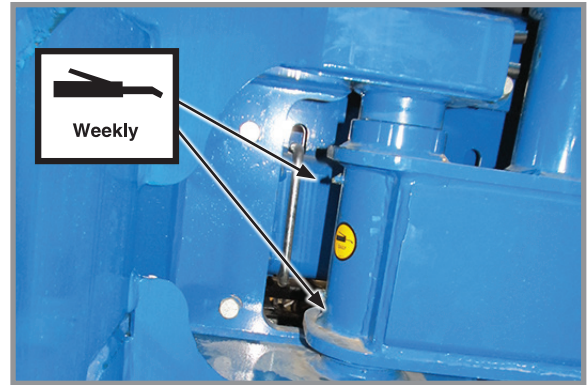

**2. Fold pivot, 2 per machine
2 fittings per pivot**

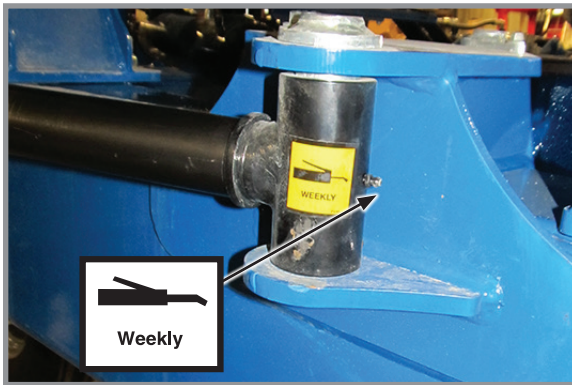

**3. Fold cylinders, 2 per machine
2 fittings per cylinder (one each end)**

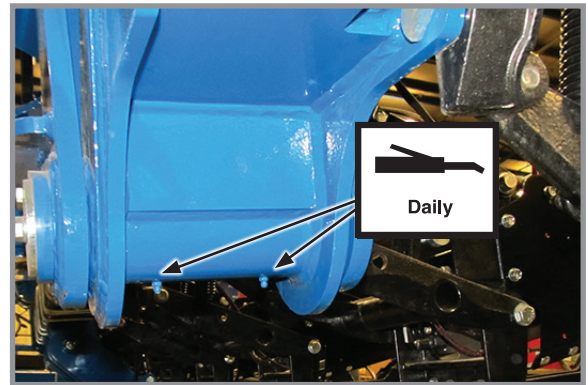

**4. Wing pivot, 2 per machine
2 fittings per pivot**

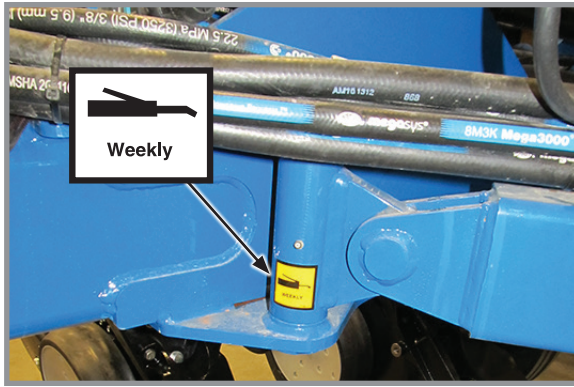

5. Draft Link, 2 per machine
1 fitting per link

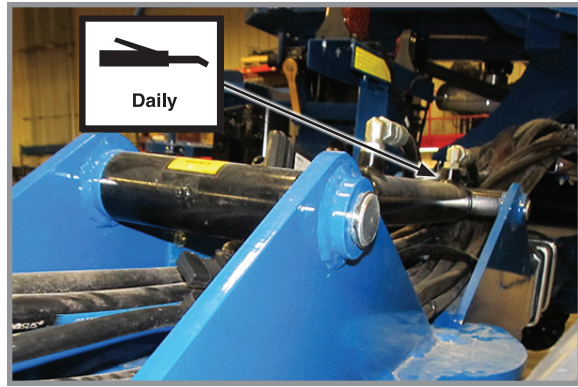

6. Wing Down Pressure Cylinder, 2 per machine
2 fittings per cylinder (one each end)

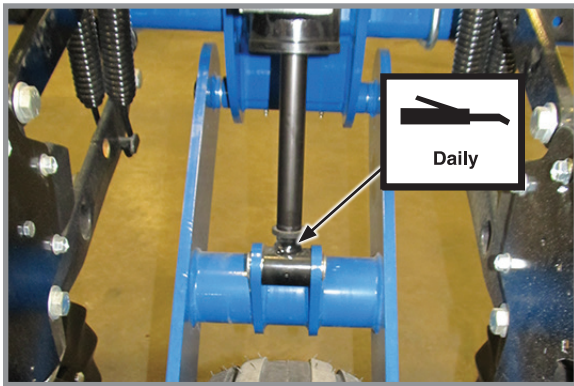

7. Lift Cylinder, 8 per machine
1 fitting per cylinder

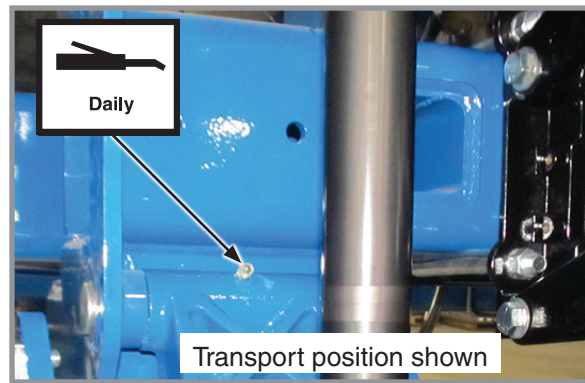
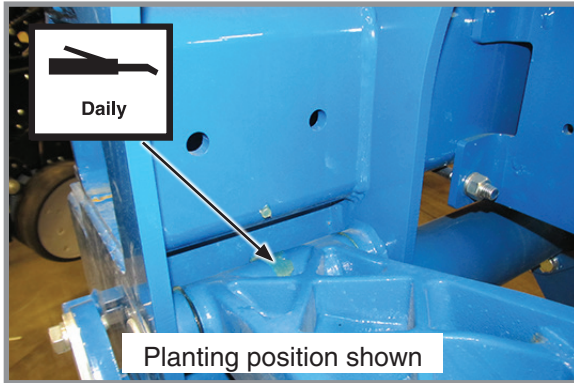
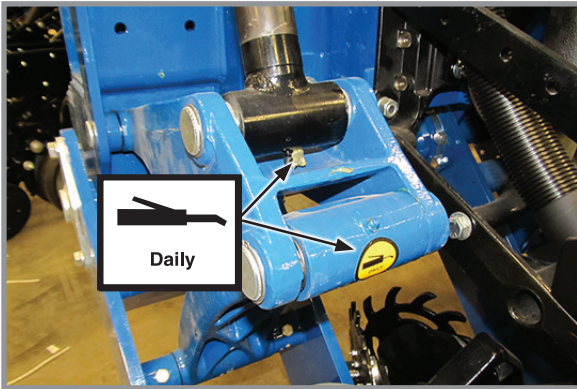

**8. Flip Axle, one each at four center wheels
4 fittings per axle**

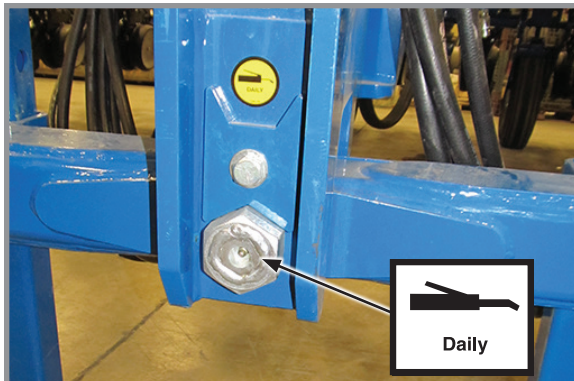

**9. 2-point Hitch, front side
1 fitting**

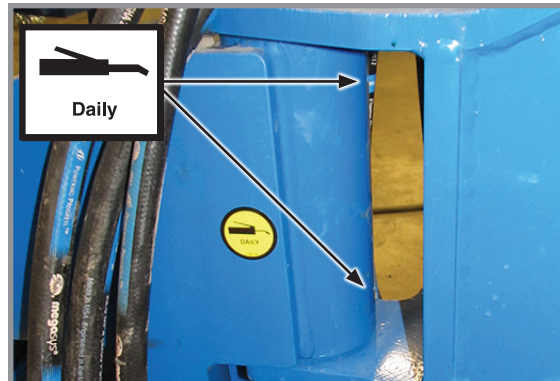

**10. 2-point Hitch, back side
2 fittings**

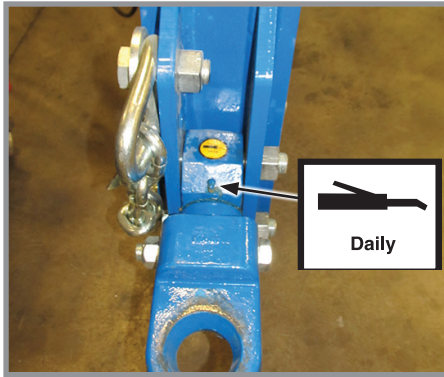

11. Drawbar Hitch
1 fitting

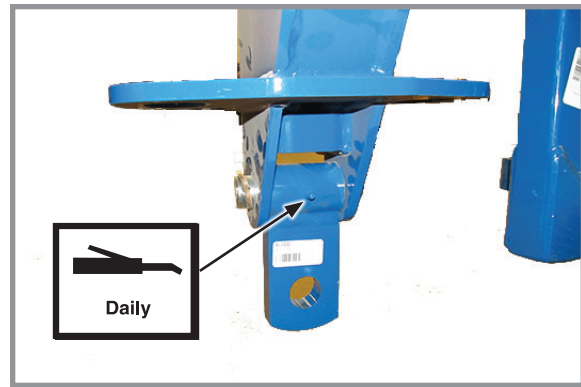

12. Trailer Hitch
1 fitting

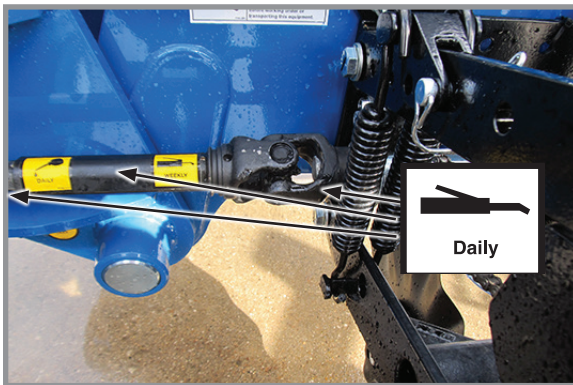

13. U-joint slide
3 fittings

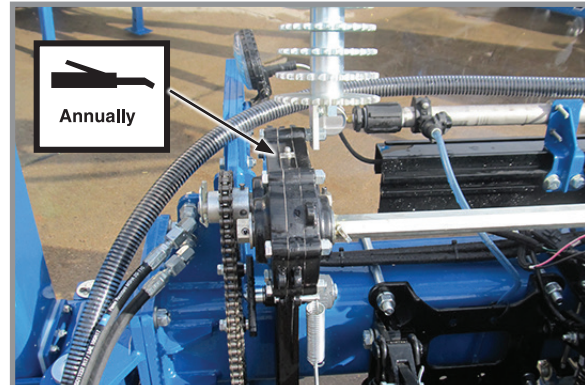

14. Transmission
1 fitting



15. Gauge wheel arms - 1 per arm
(Seals in gauge wheel arm are installed with lip facing out to allow grease to purge dirt away from seal. Pump grease into arm until fresh grease appears between washers and arm.)

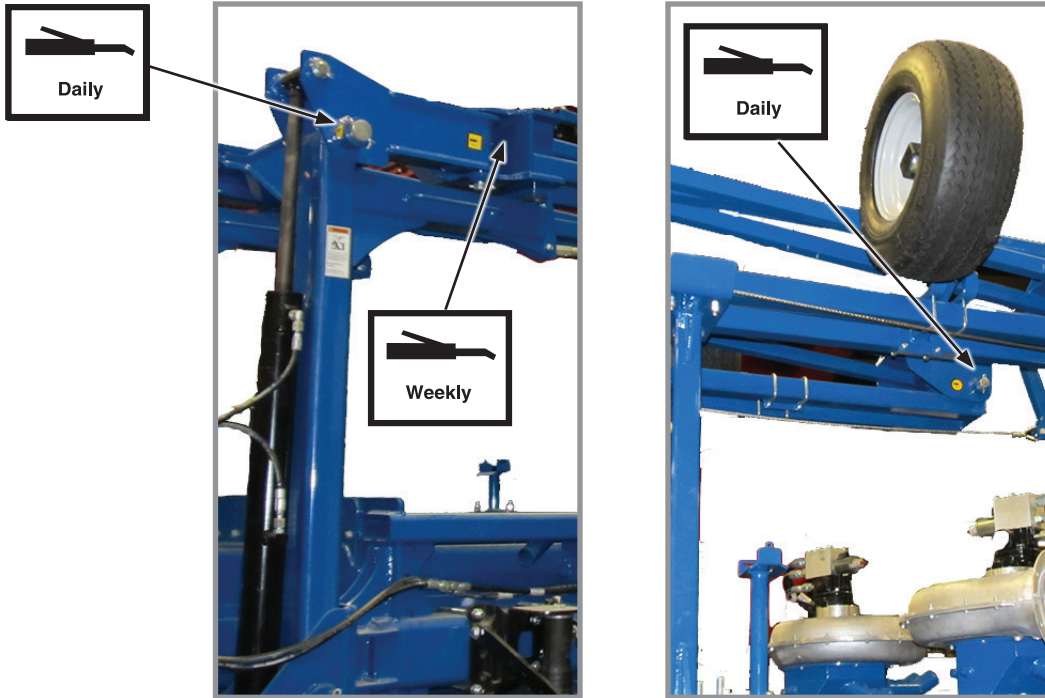

16. Row Markers (12 & 16 Row)

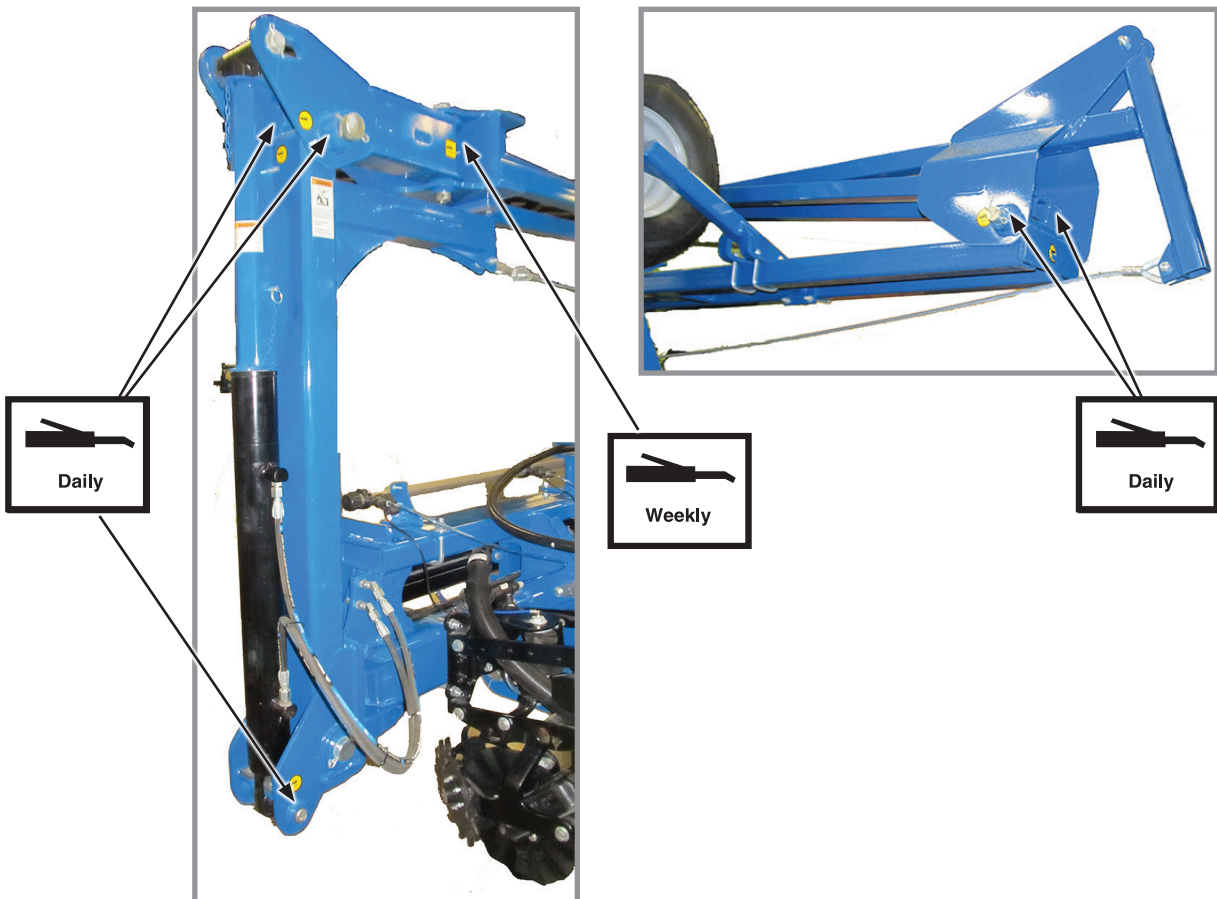

Row Markers (24 Row)

NOTCHED SINGLE DISC OPENER

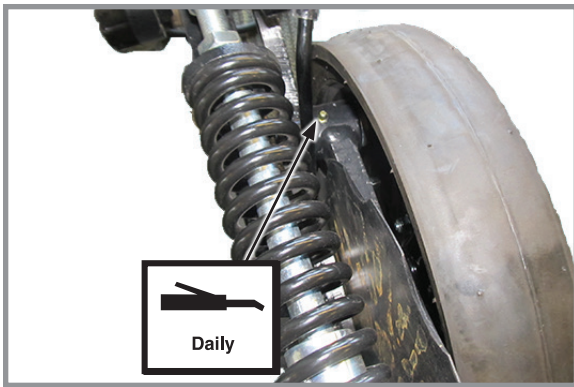

Grease to purge - 1 fitting

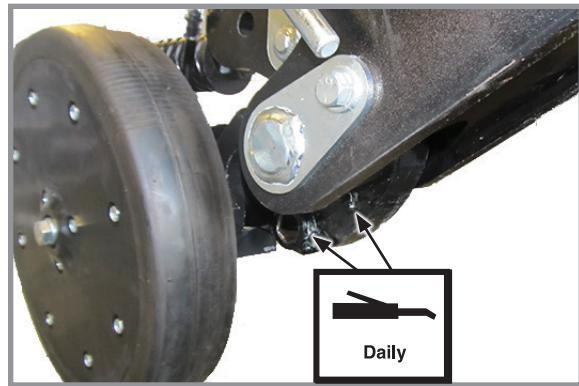

Grease to purge - 2 fittings

PTO SHAFT COUPLING

Clean and grease PTO shaft coupling each time pump is installed.

Apply coating of high-speed industrial coupling grease, such as Chevron® Coupling Grease meeting AGMA CG-1 and CG-2 Standards to extend shaft spline life.

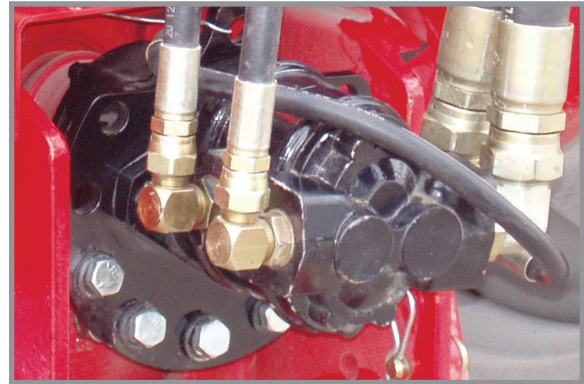

PTO Pump Installed

LIQUID FERTILIZER PISTON PUMP CRANKCASE OIL LEVEL

Check crankcase oil daily and maintain at oil level check plug. Fill as needed with EP 90 weight gear oil. Total oil capacity is approximately $\frac{3}{4}$ pint.

Refer to operator and instruction manual supplied with pump and flow divider for more information.

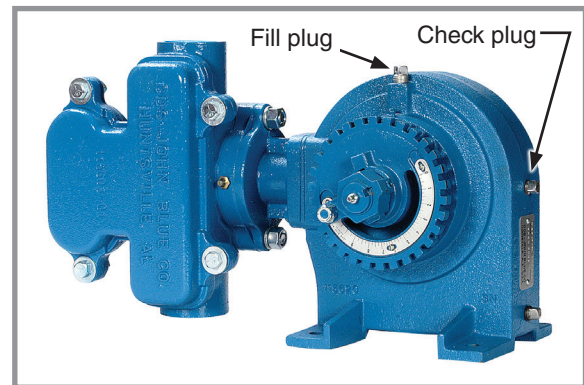

Piston Pump Oil Fill and Check Plug Locations

LIQUID FERTILIZER CENTRIFUGAL PUMP

Pumps are equipped with factory lubricated bearings and seals and require no further maintenance.

Neutralize chemicals and flush pump after each use to prevent corrosion.

Refer to operator and instruction manual supplied with pump for more information.

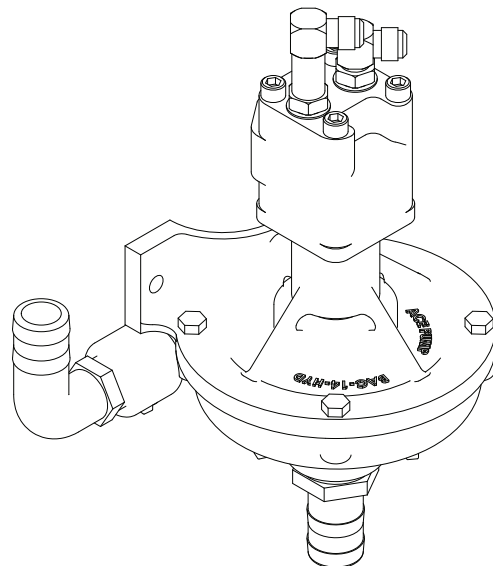

Centrifugal Pump

MOUNTING BOLTS AND HARDWARE

Before operating planter for the first time, check all hardware is tight. Check all hardware again after first 50 hours of operation and beginning of each planting season.

All hardware used on the Kinze planter is Grade 5 (high strength) unless otherwise noted. Grade 5 cap screws are marked with three radial lines on the head. Hardware must be replaced with equal size, strength, and thread type.

WARNING

Loose transport wheel lug bolts can result in wheel separation from planter and result in death, serious injury, and damage to property and equipment. Check transport wheel lug nut torque before operating planter for the first time and periodically thereafter.

NOTICE

Over-tightening hardware can reduce its shock load capacity and cause equipment failure.

TORQUE VALUES CHART - PLATED HARDWARE

Diameter	Grade 2 (No marks)		Grade 5 (3 marks)		Grade 8 (6 marks)	
	Coarse	Fine	Coarse	Fine	Coarse	Fine
1/4"	50 in-lb	56 in-lb	76 in-lb	87 in-lb	9 ft-lb (12 N-m)	10 ft-lb (14 N-m)
5/16"	8 ft-lb (11 N-m)	9 ft-lb (12 N-m)	13 ft-lb (18 N-m)	14 ft-lb (19 N-m)	18 ft-lb (24 N-m)	20 ft-lb (27 N-m)
3/8"	15 ft-lb (20 N-m)	17 ft-lb (23 N-m)	23 ft-lb (31 N-m)	26 ft-lb (35 N-m)	33 ft-lb (45 N-m)	37 ft-lb (50 N-m)
7/16"	25 ft-lb (34 N-m)	27 ft-lb (37 N-m)	37 ft-lb (50 N-m)	41 ft-lb (56 N-m)	52 ft-lb (71 N-m)	58 ft-lb (79 N-m)
1/2"	35 ft-lb (48 N-m)	40 ft-lb (54 N-m)	57 ft-lb (77 N-m)	64 ft-lb (87 N-m)	80 ft-lb (108 N-m)	90 ft-lb (122 N-m)
9/16"	50 ft-lb (68 N-m)	60 ft-lb (81 N-m)	80 ft-lb (108 N-m)	90 ft-lb (122 N-m)	115 ft-lb (156 N-m)	130 ft-lb (176 N-m)
5/8"	70 ft-lb (95 N-m)	80 ft-lb (108 N-m)	110 ft-lb (149 N-m)	125 ft-lb (169 N-m)	160 ft-lb (217 N-m)	180 ft-lb (244 N-m)
3/4"	130 ft-lb (176 N-m)	145 ft-lb (197 N-m)	200 ft-lb (271 N-m)	220 ft-lb (298 N-m)	280 ft-lb (380 N-m)	315 ft-lb (427 N-m)
7/8"	125 ft-lb (169 N-m)	140 ft-lb (190 N-m)	320 ft-lb (434 N-m)	350 ft-lb (475 N-m)	450 ft-lb (610 N-m)	500 ft-lb (678 N-m)
1"	190 ft-lb (258 N-m)	205 ft-lb (278 N-m)	480 ft-lb (651 N-m)	530 ft-lb (719 N-m)	675 ft-lb (915 N-m)	750 ft-lb (1017 N-m)
1 1/8"	265 ft-lb (359 N-m)	300 ft-lb (407 N-m)	600 ft-lb (814 N-m)	670 ft-lb (908 N-m)	960 ft-lb (1302 N-m)	1075 ft-lb (1458 N-m)
1 1/4"	375 ft-lb (508 N-m)	415 ft-lb (563 N-m)	840 ft-lb (1139 N-m)	930 ft-lb (1261 N-m)	1360 ft-lb (1844 N-m)	1500 ft-lb (2034 N-m)
1 3/8"	490 ft-lb (664 N-m)	560 ft-lb (759 N-m)	1100 ft-lb (1491 N-m)	1250 ft-lb (1695 N-m)	1780 ft-lb (2413 N-m)	2030 ft-lb (2752 N-m)
1 1/2"	650 ft-lb (881 N-m)	730 ft-lb (990 N-m)	1450 ft-lb (1966 N-m)	1650 ft-lb (2237 N-m)	2307 ft-lb (3128 N-m)	2670 ft-lb (3620 N-m)

NOTE: Torque unplated hardware and bolts with lock nuts approximately 1/3 higher than above values. Torque bolts lubricated prior to installation to 70% of value shown in chart.

CYLINDER ROD PISTON RETAINING NUT TORQUE CHART

	Non-Nylock Nut	Nylock Nut
½"-20	55-70 ft-lb (75-95 N-m)	45-55 ft-lb (61-75 N-m)
¾"-16	115-125 ft-lb (156-169 N-m)	100-115 ft-lb (136-156 N-m)
7/8"-14	150-180 ft-lb (203-244 N-m)	130-150 ft-lb (176-203 N-m)
1"-14	275-330 ft-lb (373-447 N-m)	250-275 ft-lb (339-373 ft-lb)
1 1/8"-12	300-375 ft-lb (407-508 N-m)	275-300 ft-lb (373-407 N-m)
1 1/4"-12	300-375 ft-lb (407-508 N-m)	275-300 ft-lb (373-407 N-m)

SPECIAL TORQUE VALUES & INSTRUCTIONS

Row unit parallel linkage bushing hardware	130 ft-lb (176 N-m)
5/8" No till coulter spindle hardware	120 ft-lb (162 N-m)
Row Unit Disc Opener Blade Bolt**	110 ft-lb (149 N-m) **Left hand side is left hand thread.
5/8" - 18 Wheel Lug Nuts and Lug Bolts	200 ft-lb (271 N-m)
9/16" - 18 Wheel Lug Nuts and Lug Bolts	125 ft-lb (169 N-m)
Row Unit Support (Face Plate)	90 ft-lb (122 N-m)
Notched Single Disc Opener - 3/4" L-bolts	160 ft-lb (217 N-m)
Notched Single Disc Opener - 5/8"	90 ft-lb (122 N-m)
Hex Head Cap Screws	
Notched Single Disc Opener - 3/4"	160 ft-lb (217 N-m)
Hex Set Screws	

TORQUE VALUES- ALUMINUM

Diameter	Torque Value
1/8"	180-220 in-lb
3/8"	350-380 in-lb
1/2"	350-400 in-lb
3/4"	350-400 in-lb

NOTE: Use these torque values with pneumatic down pressure components.

TIRE PRESSURE

**WARNING**

Explosive separation of rim and tire parts can cause death or serious injury. Overinflation, rim and tire servicing, improper use of rims and tires, or worn or improperly maintained tires could result in a tire explosion.



- Maintain proper tire pressure. Inflating a tire above or below the recommended pressure can cause tire damage.
- Mount tires only by properly trained personnel using proper equipment.
- Replace tires with cuts or bubbles. Replace damaged rims. Replace missing lug bolts and nuts.
- Do not weld or heat wheel assembly. Heating increases tire pressure.

TRANSPORT TIRES

**WARNING**

Overinflation of tires can result in explosive separation of rim and tire and cause death or serious injury. Different size rims are designed for different tire pressures. Inflate to correct pressure for specific rim size.



Do not exceed following maximum pressures:

- Rims stamped with “224”: 75 psi (517.1 kPa) maximum pressure.
- Rims stamped with “276”: 100 psi (689.4 kPa) maximum pressure.

INFLATION SPECIFICATIONS

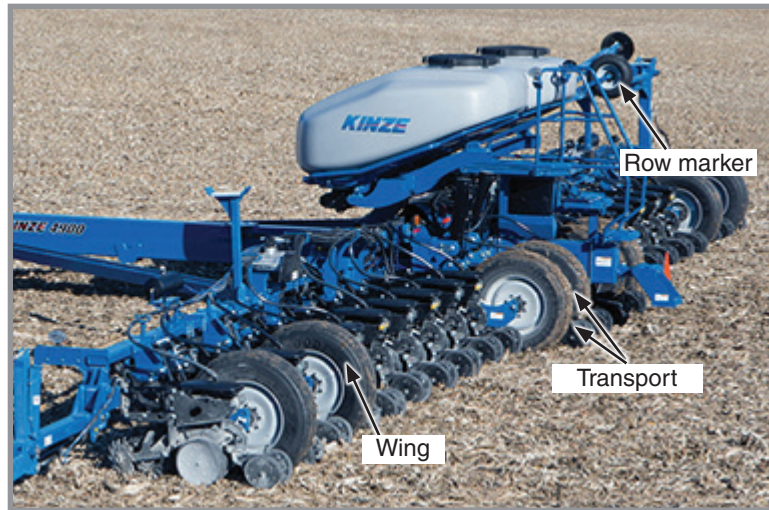
**Tire Locations (L.H. mirrors R.H. shown)**

- **2014 Production:** Wing - 12R and 16R: 7.5" x 20" - 40 psi (275.7 kPa), 24R: 41" x 11" - 60 psi (413.6 kPa)
- **2015 Production:** Wing - 12R and 16R: 7.5" x 20" - 40 psi (275.7 kPa), 24R: 11 - 22.5 - 90 psi (620.5 kPa)
- **2014 Production:** Transport - 12R: 255-70R, 22.5 - 100 psi (689.4 kPa), 16R and 24R: 41" x 11" - 75 psi (517.1 kPa)
- **2015 Production:** Transport - 12R: 255-70R, 22.5 - 100 psi (689.4 kPa), 16R and 24R: 11 - 22.5 - 90 psi (620.5kPa)
- Contact drive - 4.80" x 8" - 50 psi (344.7 kPa)
- Row marker - 16" x 6.5" x 8" - 14 psi (96.5 kPa)

Liquid fertilizer piston pump (Not shown) - 4.10" x 6" - 50 psi (344.7 kPa)

FINGER PICKUP SEED METER INSPECTION/ADJUSTMENT

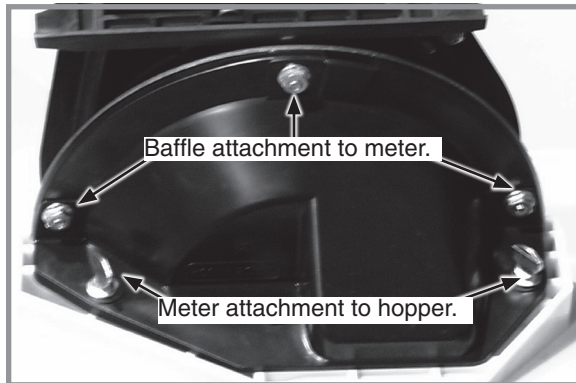

Removing meter and baffle

1. Remove two thumbscrews and meter from seed hopper and remove three cap screws and baffle from meter assembly.
2. Rotate seed meter drive by hand to ensure springs are holding tabs of fingers against carrier plate and fingers raise in correct area as shown in above photo.

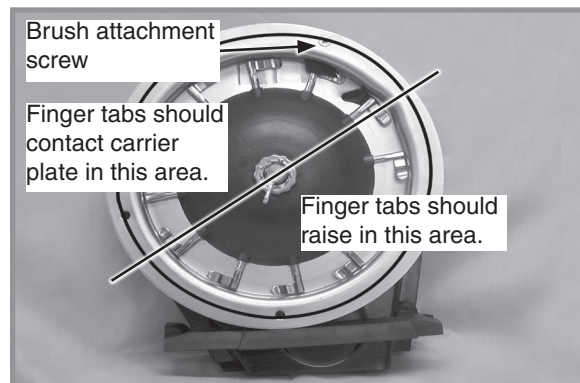

Proper finger operation

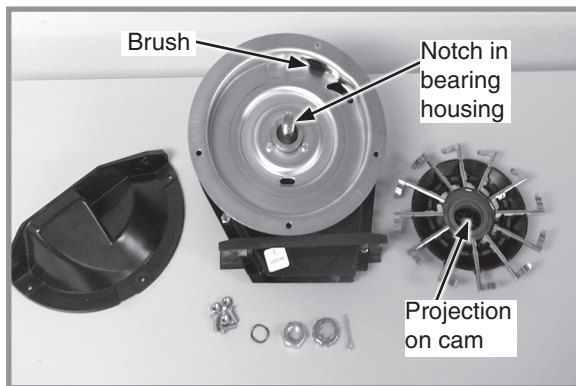

Finger pickup meter parts

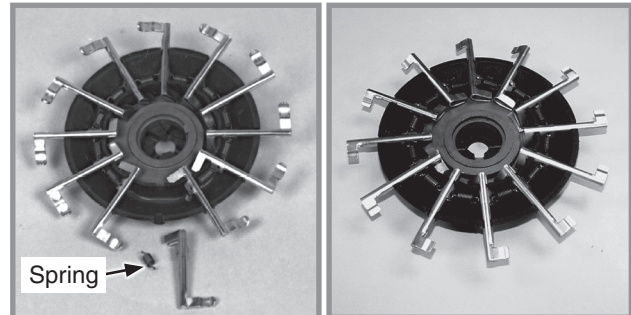

Corn Finger Assembly
(Position Spring Opening
Toward Holder)

**Oil Sunflower Finger
Assembly**

Buildup of debris or chaff may prevent proper finger operation and requires disassembly and cleaning of finger pickup meter.

1. Remove cotter pin, cover nut and adjusting nut and wave washer (If applicable) from drive shaft.
2. Carefully lift finger holder with fingers and cam off shaft and clean.
3. Check brush for wear and replace if necessary or after every 100 acres (41 hectares) per row of operation (Approximately 800 acres (324 hectares) of corn or sunflowers on a 8 row machine or 1200 acres (486 hectares) on a 12 row machine).

NOTE: It is not necessary to remove finger holder to replace brush.

4. Remove springs from fingers and remove finger from holder by lifting it out of friction fit slot. Life expectancy of these parts is about 600-900 acres (243-364 hectares) per row of operation under average conditions.
5. Reassemble meter in reverse order after cleaning and replacing defective parts. Make sure open end of spring loop is toward inside of finger holder when replacing fingers.
6. Install fingers in holder so holder is flush with carrier plate when assembled. A cam projection aligns with a mating notch in bearing housing to ensure proper operation when assembled.

7. Check indentations on carrier plate for wear before installing finger holder on carrier plate. Excessive wear of carrier plate at indentations will cause over planting especially with small sizes of seed. Inspect carrier plate annually. Life expectancy should be 250-300 acres (100-125 hectares) per row of operation under average conditions.
8. Install wave washer and adjusting nut with finger holder flush against carrier. Tighten adjusting nut to fully compress wave washer. Back off nut $\frac{1}{2}$ to 2 flats to obtain rolling torque of 22 to 25 inch pounds (2.5 N-m to 2.8 N-m).
9. Turn finger holder by hand to make sure it is firmly against carrier plate, but can be rotated with moderate force.
10. Install cover nut and cotter pin. Reinstall baffle.

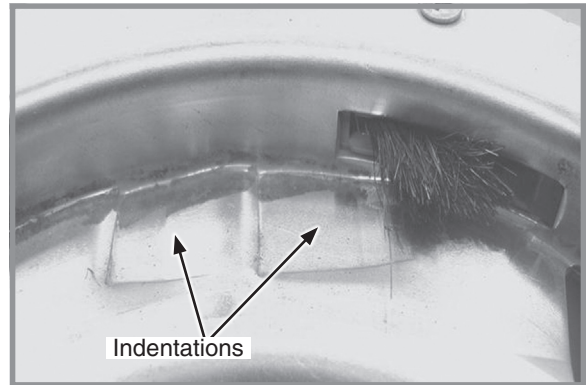

Worn carrier plate

NOTE: Check adjusting nut tightness on each unit after first day of use and periodically thereafter.

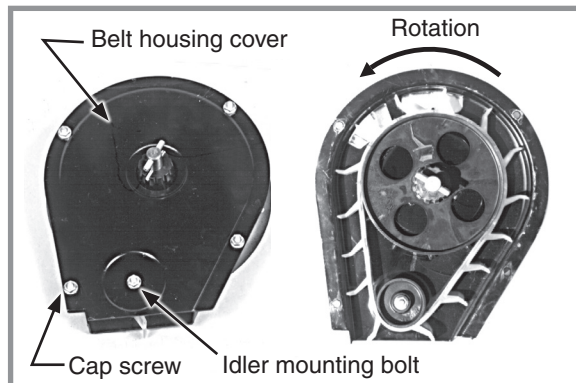

Belt idler

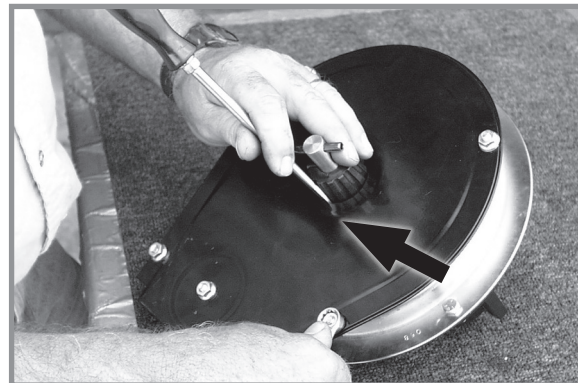

Centering belt housing cover

Remove four cap screws around edge of housing cover and nut from belt idler mounting bolt. Paddles must be correctly oriented as shown above. If belt is replaced. A diagram molded into drive sprocket shows correct orientation.

NOTICE

Do not over-tighten hardware or components may be damaged.

Reinstall housing cover. **DO NOT TIGHTEN** hardware. Wedge a screwdriver between sprocket hub and housing cover as shown above. Pry cover down until centered on belt housing and tighten hardware. Rotate meter drive shaft and check idler alignment. Seed belt should "run" centered on idler or with only slight contact with belt housing or cover.

CLEANING FINGER PICKUP SEED METER FOR STORAGE

1. Disassemble meter and blow out any foreign material.
2. Wash **ONLY** in mild soap and water. Do not use gasoline, kerosene, or any other petroleum based product. Dry thoroughly.
3. Coat lightly with a rust inhibitor.
4. Rotate finger assembly so finger does not touch brush.
5. Reassemble and store in a dry, rodent-free location.

BRUSH-TYPE SEED METER MAINTENANCE

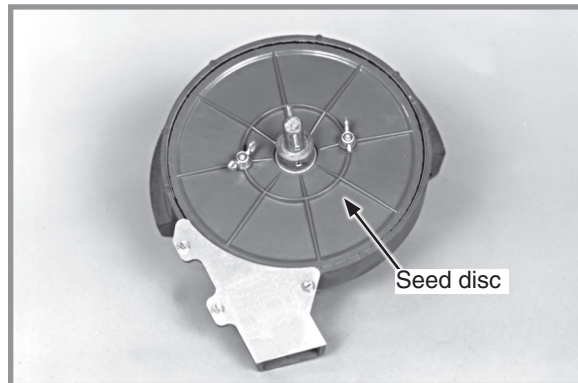

Brush-type seed meter seed disc installed

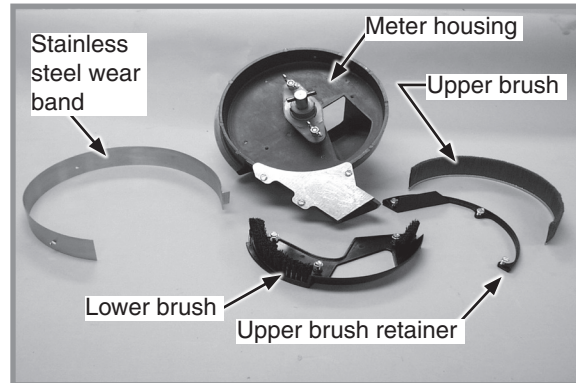

Brush-type seed meter parts

Use clean, high quality seed. Damaged or cracked seed, hulls, or foreign materials can become lodged in upper brush and greatly reduce meter accuracy. Remove seed disc daily and check for buildup of foreign material on seed disc, particularly in seed loading slots. Clean disc by washing it with soap and water. Check for cracked seed, hulls, etc. lodged between brush retainer and stainless steel wear band which can greatly reduce accuracy of the meter because upper brush will not be able to retain seed in seed disc pocket. Thoroughly clean brush areas of meter housing.

SEED DISC WEAR

Most seed disc wear is found in the agitation groove area (area between seed loading slots). Wear affects planting accuracy at high RPM. Lay a straight edge across disc surface at agitation groove area and measure gap between disc and straight edge. If agitation groove areas are worn in excess of .030" (7.6 mm) and accuracy starts to drop off at higher meter RPM, replace seed disc. Estimated seed disc life expectancy under normal operating conditions is approximately 200 acres (81 hectares) per row. Severe operating conditions such as dust, lack of lubrication or abrasive seed coating could reduce seed disc life expectancy to under 100 acres (40.5 hectares) per row.

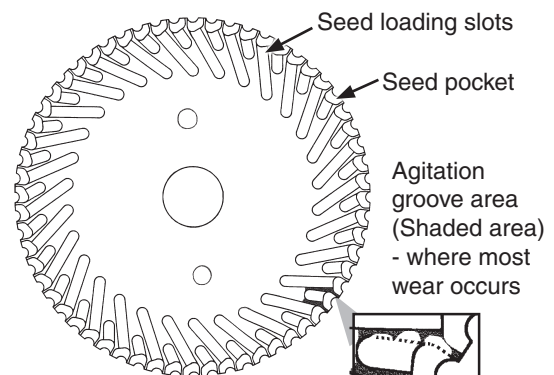

STAINLESS STEEL WEAR BAND

NOTICE

If wear band wears through or if meter is used without wear band in place, meter housing may be damaged.

Stainless steel wear band protects meter housing from wear and is .030" (.076 cm) thick. Replace wear band when there is approximately .020" (.050 cm) of wear in primary wear area. Estimated life expectancy of stainless steel wear band is 240-800 acres (97-324 hectares) per row.

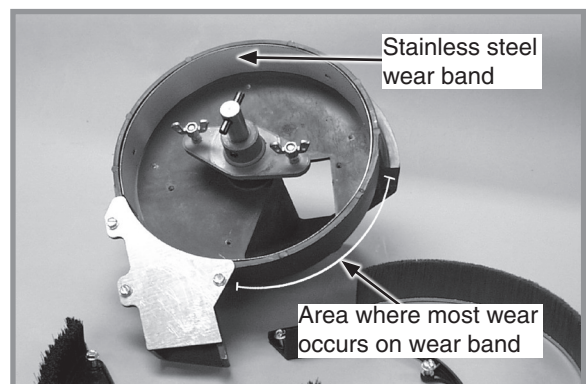

Stainless steel wear band

UPPER BRUSH

Upper brush holds seed in seed disc pocket in seed retention area. Brush must apply enough pressure against seed in seed disc pocket as disc rotates through seed retention area to prevent seed from dropping out of disc pocket. A damaged spot, excessive brush wear, or foreign material lodged in brush may greatly reduce meter performance.

Replace upper brush at 120-400 acres (49-162 hectares) per row of use or sooner if damage or excessive wear is found. Position upper brush into inner perimeter of seed retention area. Make sure base of brush is tight against bottom of meter housing. Install brush retainer and three hex head screws. Tighten screws in sequence shown in photo at right.

NOTE: Use GD11122 upper brush retainer for soybean and cotton discs. Use GD8237 upper brush retainer for milo/grain sorghum discs.

LOWER BRUSH

Lower brush moves seed down seed loading slots to seed pockets, isolates seed in reservoir from entering seed tube, and cleans seed loading slots. Estimated lower brush life expectancy is 240-800 acres per row. Replace lower brush if bristles are deformed or missing, or if there are cracks in brush retainer.

CLEANING BRUSH-TYPE SEED METER FOR STORAGE

1. Remove meter from seed hopper by removing two thumbscrews securing meter to hopper.
2. Remove seed disc and wash with soap and water and dry thoroughly.
3. Remove three hex head screws from brush retainer. Remove brush retainer and upper brush.
4. Remove three hex head screws from lower brush. Remove lower brush and stainless steel wear band.
5. Wash all parts and meter housing with soap and water and dry thoroughly.
6. Inspect all parts and replace worn parts.
7. Reassemble meter except for seed disc. Store meter in a dry, rodent-free space with seed disc removed.

VACUUM MANIFOLD MAINTENANCE

Dust accumulates in manifolds and hoses during normal operation. Clean manifolds annually. Abnormally dusty planting conditions may require more frequent cleaning.

1. Remove vacuum hose from each seed meter.
2. Operate vacuum fan at full hydraulic flow from tractor for two minutes to clear manifolds, hoses, and fittings of dust and debris.
3. Shut down fan and replace hoses

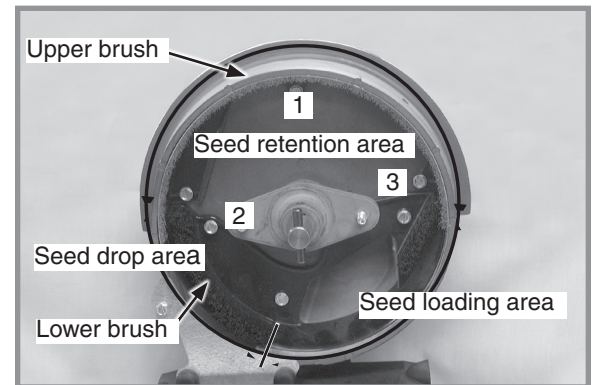

Upper brush installation

VACUUM SEED METER MAINTENANCE

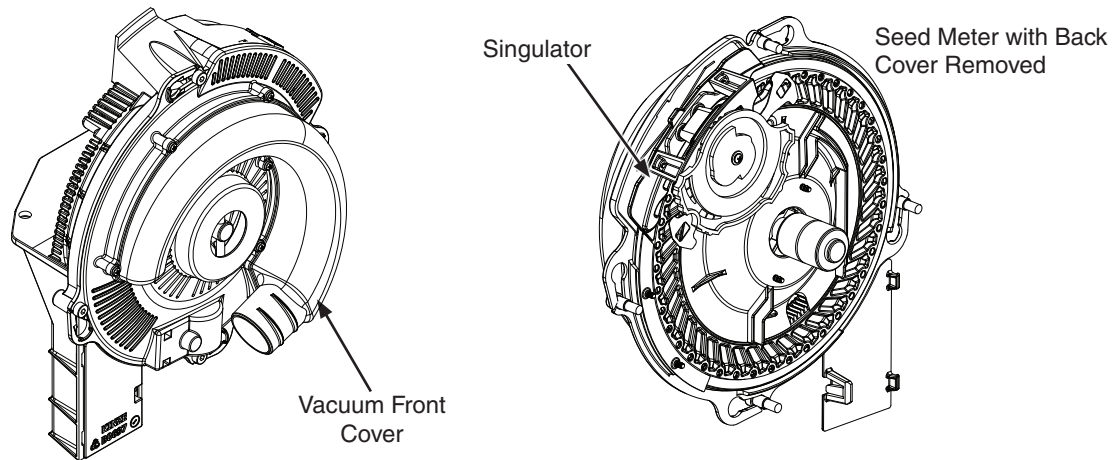

Before each planting season inspect seed discs and singulator and clean or replace as needed.

Use clean, high quality seed for maximum meter accuracy. Damaged or cracked seed, hulls, and foreign material may become lodged in seed disc orifices and greatly reduce meter accuracy.

Inspect and clean seed discs daily checking for any buildup of foreign material and blocked orifices. If seed disc orifices are plugged frequently with seed remnants, cleanout brush with ball-type ejector (if applicable) may need to be replaced. Clean seed disc by washing it with soap and water. Dry thoroughly.

Inspect singulator blades and guide for wear after every 200 acres (81 hectares) per row of operation. If adjustment of singulator blade does not affect meter performance or if blades appear worn, singulator blade may need to be replaced.

Replace seed disc or vacuum seal if abnormally high vacuum is required or if consistent operation cannot be achieved. See "[Preparation for Storage](#)" on page 6-33 for additional Vacuum Seed Metering System maintenance.

NOTE: Remove seed discs from meters for annual storage and store them vertically on a dowel or pipe.

SEED METER CLEANOUT

NOTE: Use of damaged seed or seed containing foreign material will cause plugging of seed cell orifices and require more frequent seed meter cleanout to prevent underplanting.

Thorough seed meter cleanout is important to maintain genetic purity.

1. Disengage seed drive and remove seed hopper and meter.
2. Dump seed from right rear corner of hopper into a container.
3. Lay hopper on its right side. Push release button and rotate seed meter vacuum cover clockwise to align keyhole slots with bolt heads. Lift off cover.
4. Rotate seed disc hub clockwise to unlock and remove seed disc.
5. Empty meter.
6. Thoroughly inspect meter to ensure all seed is removed.
7. Replace seed disc. Install vacuum cover.

FERTILIZER FLOW SENSOR CLEANOUT

Fertilizer can salt out when certain conditions of time and temperature are met. This causes a buildup of fertilizer granules in and around areas of low flow. This will cause errors in the performance of the fertilizer flow switches.

Refer to the photo below for an example of a clean sensor and a dirty sensor.



Follow these instructions to direct the cleanout of the fertilizer flow switches and return them to optimum performance. It is recommended that this procedure be followed at the end of each season.

1. Remove the hose from the supply side of the flow sensor (labeled "IN" on the housing) by pushing in the retaining ring while pulling on the hose.
2. Remove the 1/4" NPT adapter from the sensor housing.
3. Remove the stop screw from the opposite side of the housing.

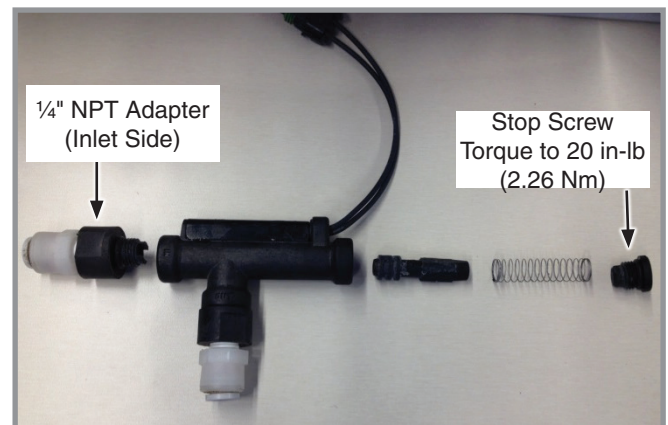

NOTE: The spring may be stuck onto the screw. Do not pull on spring.

FERTILIZER FLOW SENSOR CLEANOUT (CONTINUED)

4. Insert a $\frac{3}{16}$ " drift punch through the inlet of the flow switch, centered on the piston dome. Push the piston and spring out through the opening of the stop screw.

NOTE: To avoid damage to the piston, use the least amount of force possible.

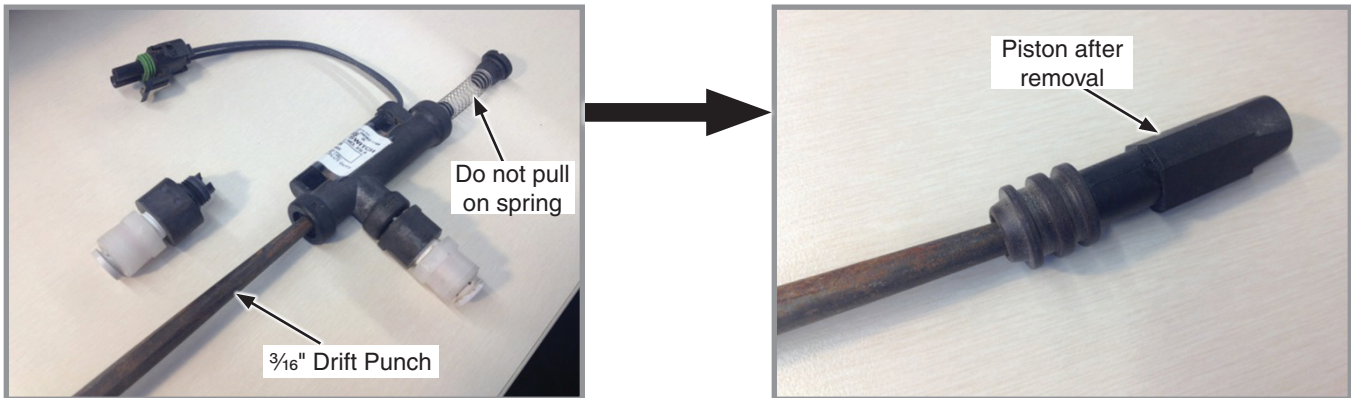

5. Wash the spring, piston, cap screw and housing interior with warm, soapy water and a soft brush.
6. Insert the piston, spring and plug into the housing. Tighten the plug to 20 in-lb (2.26 Nm).
7. Screw $\frac{1}{4}$ " NPT adapter into the input side of the housing and tighten.
8. Push the hose back into the supply side of the sensor. Tug on hose to make sure it is secure, then push it in a second time.
9. Verify there are no leaks by using the fertilize prime feature in the fertilizer tab. Leaks could be caused by hoses not being pushed into the fittings far enough, or by damaged or missing o-rings.

VACUUM MANIFOLD MAINTENANCE

Dust accumulates in manifolds and hoses during normal operation. Clean manifolds annually. Abnormally dusty planting conditions may require more frequent cleaning.

1. Remove vacuum hose from each seed meter.
2. Operate vacuum fan at full hydraulic flow from tractor for two minutes to clear manifolds, hoses, and fittings of dust and debris.
3. Shut down fan and replace hoses.

GAUGE WHEEL ADJUSTMENT

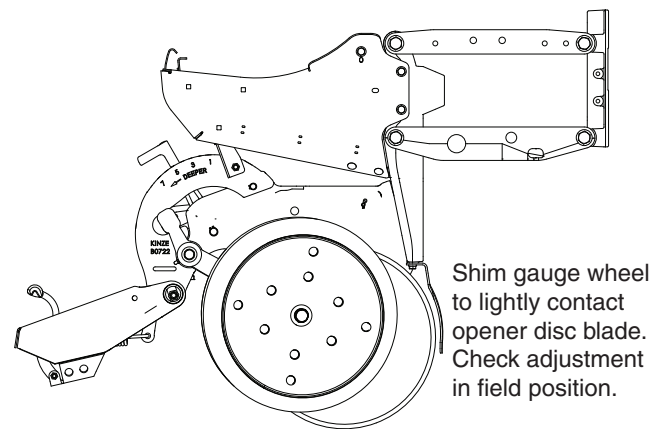
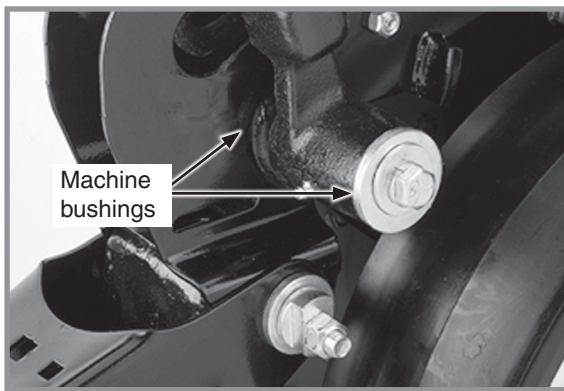

Gauge Wheel Adjustment

Gauge wheels should lightly contact opener blades to prevent accumulation of dirt or trash. Gauge wheels and opener blades should turn with only slight resistance.

Add or remove machine bushings between shank and gauge wheel arm to adjust clearance between gauge wheels and opener blades. Store remaining machine bushings between gauge wheel arm and flat washer on outer side of gauge wheel arm.

NOTE: It may be desirable to space gauge wheel further from blade when operating in sticky soils.

GAUGE WHEEL ARM PIVOT SPINDLE REPLACEMENT

1. Remove gauge wheel and arm assemblies from shank assembly.
2. Remove $\frac{1}{2}$ " x $\frac{3}{4}$ " cap screw that locks pivot spindle in place and remove spindle.
3. Install replacement spindle and position as shown. Exact centering is critical.
4. Install $\frac{1}{2}$ " x $\frac{3}{4}$ " cap screw and torque to lock pivot spindle in place.
5. Install gauge wheel and arm assemblies. Shim for proper gauge wheel tire/disc blade clearance.

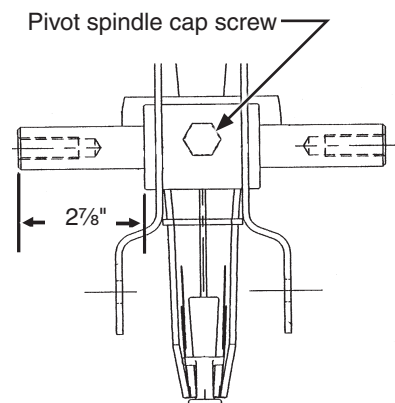

GAUGE WHEEL ARM BUSHING/SEAL REPLACEMENT

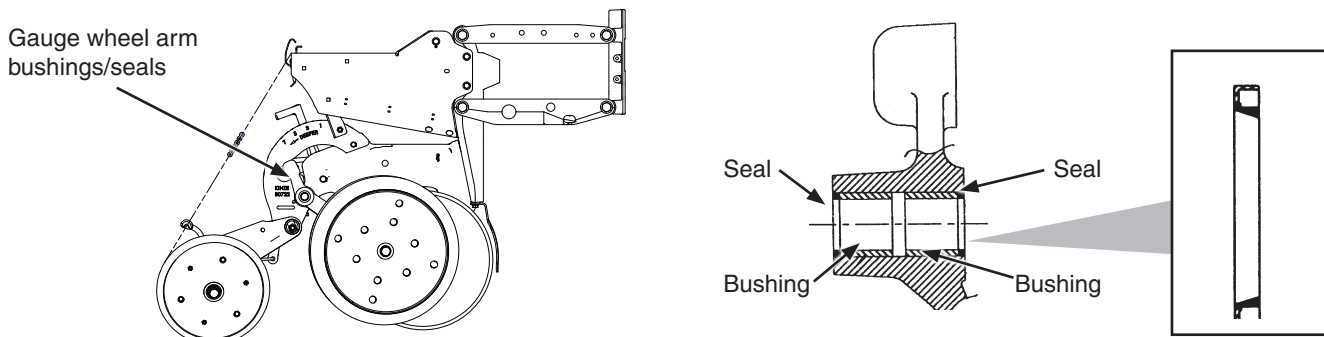

NOTE: Gauge Wheel Arm Bushing and Seal Driver Kit (G1K296) is available through your Kinze Dealer.

1. Remove gauge wheel from arm.
2. Remove gauge wheel arm from shank assembly.
3. Remove seal and bushing and discard. Clean and dry inner bore.
4. Drive/press replacement bushing inside bore of arm to a depth of .125" (.31 cm) below flush.
5. Coat wiping edge of seal with grease.
6. Drive/press seal into place with lip to outside.

NOTE: Use extra care to protect the sealing lip during installation. Apply uniform pressure to assemble the seal into the bore of the arm. Never apply a direct hammer blow to the seal surface.

7. Inspect gauge wheel pivot spindle.
8. Reinstall gauge wheel arm assembly and gauge wheel.

NOTE: Use special machine bushing between gauge wheel arm and gauge wheel.

9. Shim for proper gauge wheel tire/disc blade clearance.
10. Lubricate with an SAE multipurpose grease.

15" SEED OPENER DISC BLADE/BEARING ASSEMBLY

NOTICE

Excessive blade contact may result in premature disc opener bearing/hub failures and excessive wear on seed tube guard/inner scraper. When properly adjusted, if one blade is held in fixed position, opposite blade should rotate with less than 5 pounds force (22 newtons) at outer edge of blade.

Maintain approximately $1" \pm \frac{1}{2}"$ (3 ± 5 cm) of blade-to-blade contact to properly open and form seed trench. As blade diameter decreases due to wear, it is necessary to relocate machine bushings from inside to outside to maintain $1" \pm \frac{1}{2}"$ (3 ± 5 cm) of contact.

NOTE: Proper blade clearance is critical. Blades should have $1" \pm \frac{1}{2}"$ (3 ± 5 cm) contact in this area. When blades are turned by hand in opposite directions against each other, there should be only light resistance to turning. Re-adjust blade scraper if necessary to center it between the blades.

NOTE: Replace blades if proper blade-to-blade contact cannot be maintained after relocating machine bushings or if blade diameter wears below $14\frac{1}{2}"$ (36.8 cm).

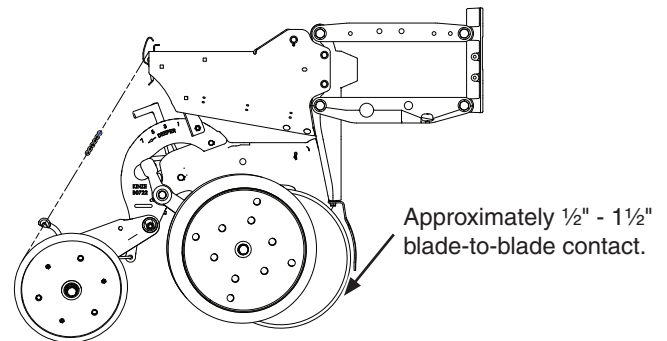

REPLACE DISC BLADE/BEARING ASSEMBLY

NOTE: Only bearing may need to be replaced if there is excessive endplay or if bearing sounds or feels rough when disc blade is rotated.

1. Remove gauge wheel, scraper, and bearing dust cap.
2. Remove cap screw, washer and disc blade/bearing assembly. Machine bushings between shank and disc blade are used to maintain approximate $1" \pm \frac{1}{2}"$ (3 ± 5 cm) of blade-to-blade contact.

NOTICE

Left hand side of opener uses a left hand threaded cap screw. **DO NOT OVER TIGHTEN.** Damage to shank threads require replacement of row unit shank assembly.

3. Install machine bushing(s), new disc blade bearing assembly, washer and cap screw. Torque $\frac{5}{8}"$ -11 Grade 5 cap screw to 110 ft-lb (149.14 N-m).

NOTE: Replace disc blades only with disc blades of equal thickness.

4. Install bearing dust cap, scraper, and gauge wheel.

15" SEED OPENER DISC BLADE/BEARING ASSEMBLY (CONTINUED)

REPLACE BEARING ONLY

1. Remove gauge wheel, scraper, bearing cap, cap screw, washer and disc blade/bearing assembly.
2. Remove ¼" rivets from bearing housing to expose bearing.
3. Installing new bearing. install three evenly spaced ¼" cap screws into three of six holes in bearing housing to hold bearing and bearing housing in place. Install rivets in other three holes. Remove ¼" cap screws and install rivets in those three holes.
4. Reinstall disc blade/bearing assembly, washer and cap screw. Torque ⅝"-11 cap screw to 110 ft-lb (149.14 N-m).
5. Install bearing dust cap, scraper, and gauge wheel.

SEED TUBE GUARD/INNER SCRAPER

Seed tube guard protects seed tube and acts as inner scraper for seed opener disc blades.

Remove seed tube and check for wear. Excessive wear on seed tube indicates a worn seed tube guard. Replace seed tube guard if it measures ⅝" (1.6 cm) or less at lower end. A new seed tube guard measures approximately ⅞" (2.2 cm).

NOTE: No till planting or planting in hard ground conditions, especially when planter is not equipped with no till coulters, and/or excessive blade-to-blade contact increases seed tube guard wear and requires more frequent inspection and/or replacement.

Remove gauge wheel and disc blade from one side of row unit. Lift up inner scraper approximately 90° to remove from slot when replacement is necessary.

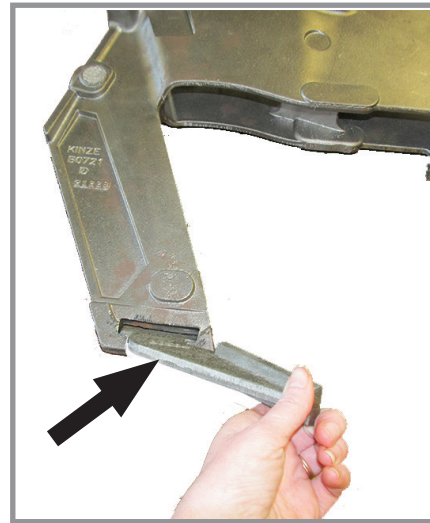

**Seed Tube Guard/Inner Scraper
(Gauge wheel/seed opener disc blade removed
for easier identification of scraper)**

ROW UNIT MOUNTED NO TILL COULTER

Check nuts and hardware periodically for proper torque.

NOTE: Torque $\frac{5}{8}$ " spindle hardware to 120 ft-lb (162 N-m).

Be sure coulters are positioned square with row unit and aligned in front of row unit disc opener.

Coulter blade can be adjusted to one of four settings. Initially blade is set in highest position. As blade wears it can be adjusted to one of three lower settings. See "Row Unit Mounted No Till Coulter" in Row Unit Operation section of this manual.

Replace 16" diameter coulters when worn to 14½" (37 cm).

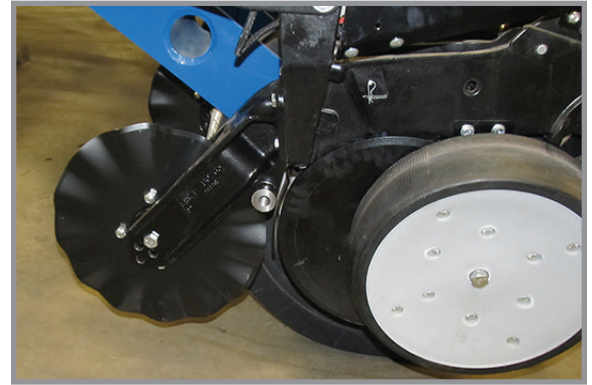

Row Unit Mounted No Till Coulter

COULTER OR ROW UNIT MOUNTED RESIDUE WHEELS

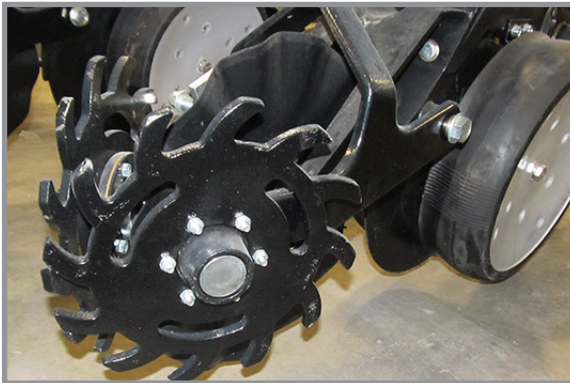

Coulter Mounted Residue Wheels

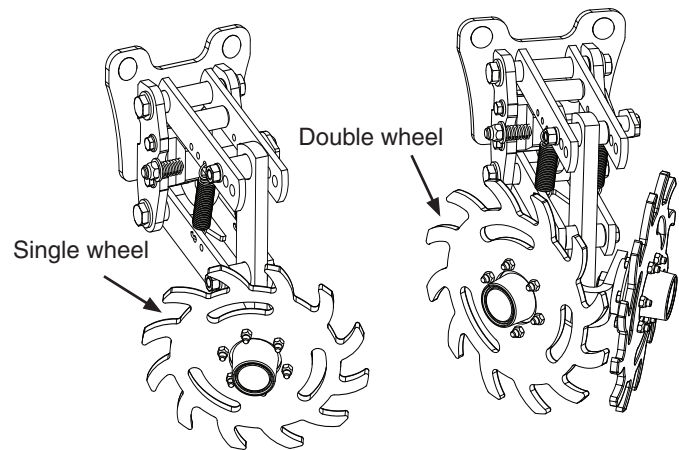

Row Unit Mounted Residue Wheels

Wheel hubs are equipped with sealed bearings. If a bearing sounds or feels rough when wheel is rotated, replace them.

SPIKED CLOSING WHEEL

Inner parts of spiked closing wheel will begin to wear at approximately 70% of life. Flip/reverse wheel to utilize remaining life of wheel.

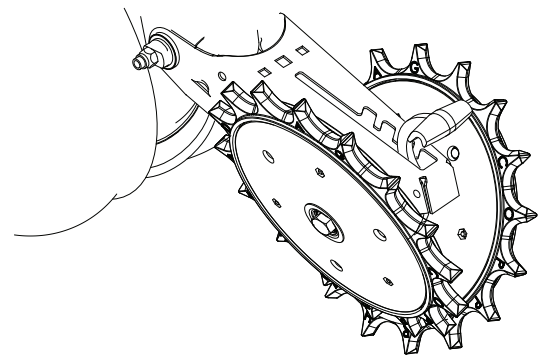

Row Unit Spiked Closing Wheel

GFX HYDRAULIC ROW CLEANERS

WARNING

Pressurized hydraulic fluid can penetrate body tissue and result in death, serious infection, or other injuries. Fluid injected under skin must be IMMEDIATELY removed by a surgeon familiar with this type of injury. Make sure connections are tight and hoses and fittings are not damaged before applying system pressure. Leaks can be invisible. Keep away from suspected leaks. Relieve pressure before searching for leaks or performing any system maintenance.



Lubrication is not required on the Gfx arm and cylinder assembly. Pivot bushings on cylinder and arm are greaseless, never-seize was applied during assembly to prevent corrosion. Under extreme use in conditions where very abrasive soils are present it is advisable to unbolt arms to clean and re-lubricate bushings annually.

Lubricate trashwheel hubs on gfx unit, every 120 acres per row:

1. Remove pipe plugs and install a grease zerk for greasing.
2. Inject grease into hub until clean grease comes out around seal area at the back of hub.
3. Wipe off excess grease with a clean rag.

STORAGE

At the end of each season gfx row units should be hosed down to remove excess grit. A pressure washer may be used, however strong solvents and soaps should NOT be used. For best results the planter should be connected to tractor and the gfx system hydraulic pressure should be set at around 50%. This will allow the cylinder rod to be extended slightly so any dirt and debris around the cylinder rod seal can be flushed out. Use the pressure washer without heat and lightly hose off the area around the rod seal to flush any debris that might have become lodged in that area. After completion, cycle the units up and down a few times and release all hydraulic pressure to continue cleaning.

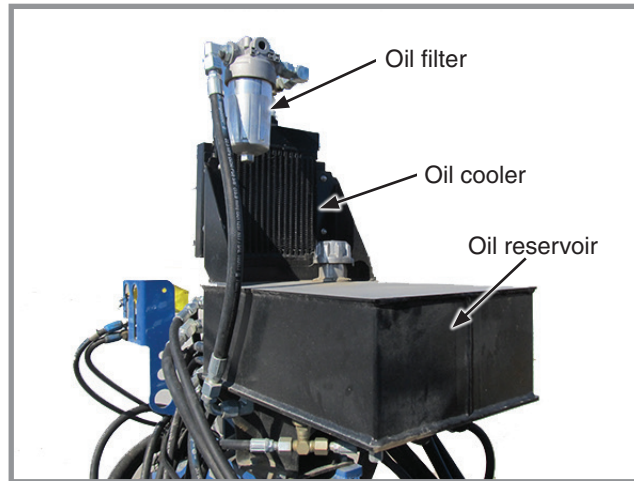
TRACTOR MOUNTED PUMP DRIVE AND OIL COOLER**NOTICE**

Clean and grease PTO shaft coupling with high-pressure industrial coupling grease (Chevron® coupling grease or equivalent) meeting AGMA CG-1 and CG-2 Standards each time driveshaft is installed or premature wear and equipment failure can occur.

NOTE: Periodically check and clean oil coolers.

1. Replace 10-micron spin-on filters on tank annually.
2. Fill system with SAE 10W-20 multigrade wide temperature range transmission hydraulic fluid. Reservoir capacity is approximately 8 gal (30.2L).
3. Start system and run with tractor at idle and fans turned off for 1-2 minutes. Switch fans to full speed and run with tractor at idle for 1-2 minutes.
4. Check reservoir fluid level and fill as required. Hydraulic fluid level should be within 1"-2" (2.5 - 5 cm) from top of reservoir after pump has run and hydraulic hoses have been primed to allow fluid to expand when heated.

CHECK VALVE

A check valve is located in each vacuum fan motor block assembly and operates as a return line check to prevent vacuum fan motor reverse operation. Remove and inspect valve. If it does not operate properly. Check for foreign material and if O-ring is leaking internally. Replace if defective.

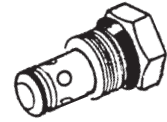

FLOW CONTROL VALVES

Two flow control valves are located in valve block on right wing of planter. Flow control valves should be adjusted for row marker raise and lower speed as part of assembly procedure or upon initial operation. If valve fails to function properly or requires frequent adjustment, it should be removed for inspection. Check for foreign material and contamination on valve and seating areas of valve body. Replace defective components.

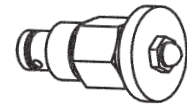

PRESSURE RELIEF VALVES

Pressure relief valve in valve block on left wing of planter functions during lowering out of raised transport sequence. Valve is factory set and should require no additional adjustment. Pressure relief valve located in valve block on tongue functions during tongue extend cycle. This pressure relief valve ensures latch cylinder extends and releases prior to tongue extending. Valve is factory set and should require no additional adjustment. Contact your Kinze Dealer for service.

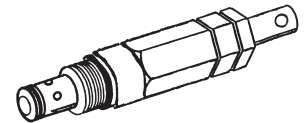
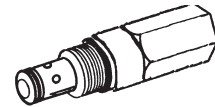

NOTICE

Connect hydraulic motor case drain to a case drain return line with zero pressure on tractor or hydraulic motor will be damaged. DO NOT connect hydraulic motor case drain to SCV outlet. Contact tractor manufacturer for specific details on “zero pressure return”.

PRESSURE COMPENSATED FLOW CONTROL VALVES

There are three pressure compensated flow control valves used on the planter. One is located on the vacuum fan block, on the ASD fan block and on the power pack block.

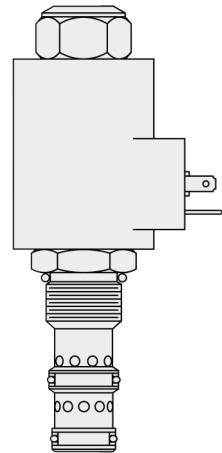

SOLENOID VALVE

Solenoid valve consists of a chambered body with an electric coil actuated cartridge valve.

If solenoid or solenoids fail to operate, first determine if problem is electrical or hydraulic. If valve is working properly, a click will be heard when solenoid coil is energized and valve stem opens. If no sound is heard, check solenoid coil by touching top of coil housing with a metallic object such as a pliers or screwdriver. If coil is working properly, coil housing will be strongly magnetized when energized. If voltage to coil is low it will be weakly magnetized when energized and no click will be heard.

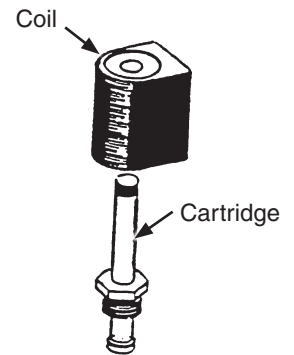

PNEUMATIC DOWN PRESSURE AIR COMPRESSOR TANK

Moisture should be drained daily from the tank. Tank should be drained completely for storage.

To drain tank, locate drain plug on the bottom of tank. Stand off to the side of tank and pull cable attached to drain.

NOTE: If moisture is not drained from tank rust particles will form inside tank.

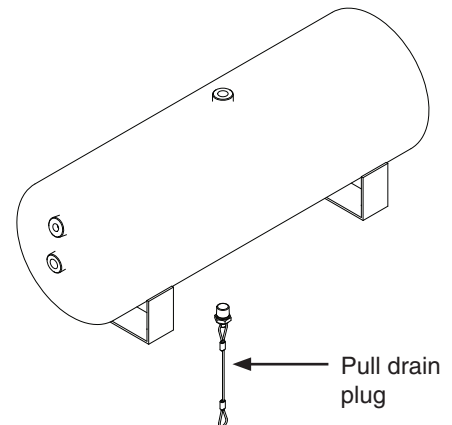

ROW MARKER BEARING LUBRICATION OR REPLACEMENT

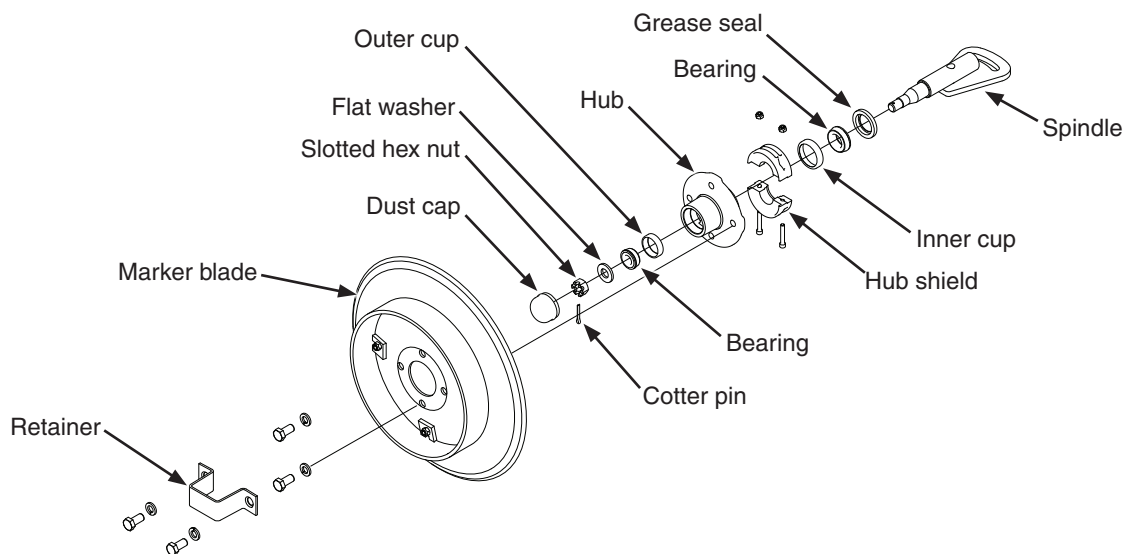

1. Remove retainer and marker blade.
2. Remove dust cap from hub.
2. Remove hub shield. Note direction of installation.
3. Remove cotter pin, slotted hex nut, and washer.
4. Slide hub from spindle.
5. Remove bearings and cups and discard if bearings are being replaced. Clean hub and dry. Remove bearings only and not cups if repacking.
6. Press in new bearing cups with thickest edge facing in. (Bearing replacement procedure only.)
7. Pack bearings with heavy duty wheel bearing grease thoroughly forcing grease between roller cone and bearing cage. Fill the space between the bearing cups in the hub with grease.
8. Install rubber seal into grease seal. Place inner bearing in place and press in new rubber seal/grease seal.
9. Clean spindle and install hub.
10. Install outer bearing, washer and slotted hex nut. Tighten slotted hex nut while rotating hub until there is some drag. This ensures all bearing surfaces are in contact. Back off slotted nut to nearest locking slot and install cotter pin.
11. Fill dust caps approximately $\frac{3}{4}$ full of wheel bearing grease and install on hub.
12. Install hub shield.
13. Install marker blade and retainer on hub. Tighten hardware evenly.

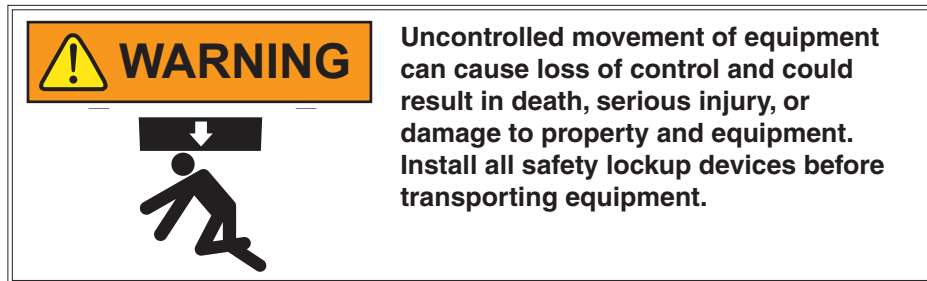

TRANSPORT AND LIFT/GROUND DRIVE WHEEL BEARING REPACK OR REPLACEMENT

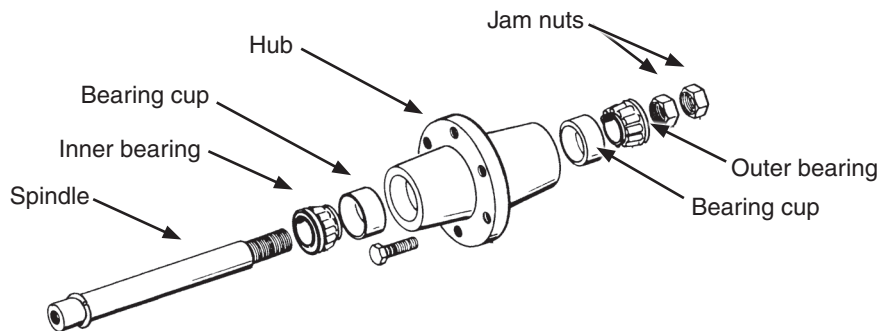

1. Raise tire clear of ground and remove wheel.
2. Remove double jam nuts and slide hub from spindle.
3. Remove bearings and cups and discard if bearings are being replaced. Clean hub and dry. Remove bearings only and not cups if repacking.
4. Press in new bearing cups with thickest edge facing in. (Bearing replacement procedure only.)
5. Pack bearings with heavy duty wheel bearing grease thoroughly forcing grease between roller cone and bearing cage. Fill space between bearing cups and hub with grease.
6. Place inner bearing in place.
7. Clean spindle and install hub.
8. Install outer bearing and jam nut. Tighten jam nut while rotating hub until there is some drag. This ensures all bearing surfaces are in contact. Back off jam nut $\frac{1}{4}$ turn or until there is only slight drag when rotating hub. Install second jam nut to lock against first.
9. Install wheel on hub. Tighten hardware evenly. Refer to the torque chart information included previously in this section.

FERTILIZER CHECK VALVE CLEANING AND REPAIR

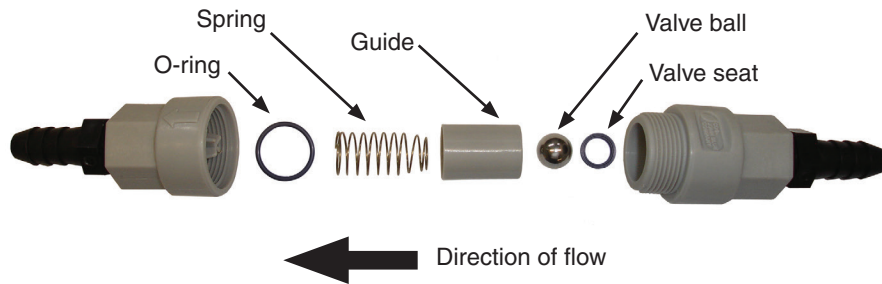

1. Unscrew valve body and separate halves. Note direction and location of parts.
2. Clean and inspect parts. Flush with clean water. Replace damaged parts.
3. Reassemble exactly as shown. O-ring and valve seat must be firmly in place inside each half of valve body.

PISTON PUMP STORAGE

NOTICE

Entrance of air into pump will cause rapid and severe corrosion. **KEEP AIR OUT OF PUMP!**

NOTE: SUSPENSION FERTILIZER must be flushed from pump for ANY storage period.

1. Flush pump with 5 to 10 gallons (19 to 38 L) of fresh water and circulate until all corrosive salts are dissolved in pump.
2. Set pump on 10. Draw in a mixture of half diesel fuel and 10 weight oil until discharge is clean. Plug inlet and outlet.

CENTRIFUGAL PUMP STORAGE

1. Flush out entire system of pump and lines with clean water and neutralize chemicals.
2. Fill entire system of pump and lines with recreational vehicle antifreeze to protect from corrosion and freezing.

If danger of freezing exists, drain pump by removing bottom pipe plug.

PREPARATION FOR STORAGE

Store planter in a dry sheltered area if possible.

Remove all trash wrapped on sprockets or shafts and remove dirt that can draw and hold moisture.

Clean all drive chains and coat with a rust preventative spray, or remove chains and submerge in oil.

Lubricate planter and row units at all lubrication points.

Inspect planter for parts that in need of replacement and order during “off” season.

Make sure all seed and granular chemical hoppers are empty and clean.

Remove seed discs from seed meters, clean and store meters in a rodent-free, dry area with discs removed. Store seed discs vertically on a dowel or pipe.

Remove vacuum hose from each seed meter. Operate vacuum fan at full hydraulic flow from tractor for two minutes to clear manifolds, hoses and fittings of dust and debris.

Clean breather on analog vacuum and pressure gauges.

Disassemble, clean and grease all U-joint slides.

Grease or paint disc openers/blades and row marker disc blades to prevent rust.

Flush liquid fertilizer tanks, hoses and metering pump with clean water. See “Piston Pump Storage” if applicable.

Bulk Fill System:

- Clean out bulk fill hopper, entrainment assembly, and delivery hoses.
- Disconnect delivery hoses from entrainer ports. Install small orange caps onto ports. Attach hoses to caps.
- Disconnect delivery hoses from air dissipator at each row unit. Install large orange caps. Attach hoses to caps.
- Check all bolts and fasteners used to assemble and attach entrainment device are tight (if applicable).
- Loosen knobs on entrainer cleanout doors to remove pressure from door gaskets.
- Inspect all seed delivery hoses and replace any that are worn, cut, or cracked.

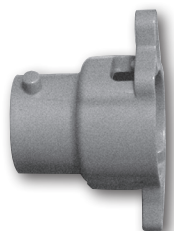

Entrainer Cap

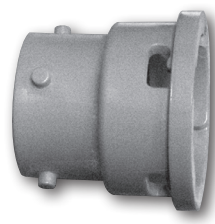

Air Dissipator Cap

CONTROL BOX ELECTRICAL SCHEMATIC

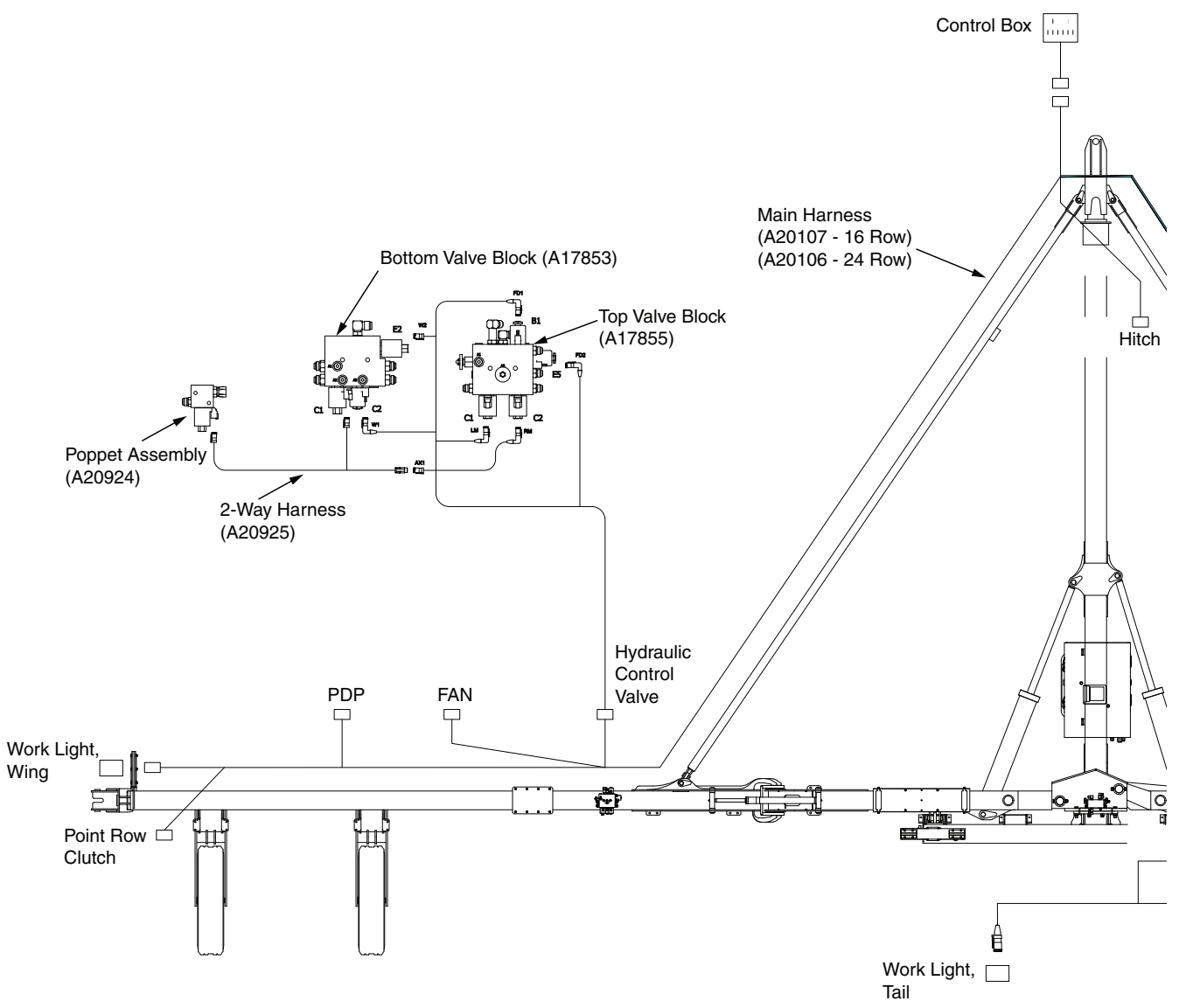

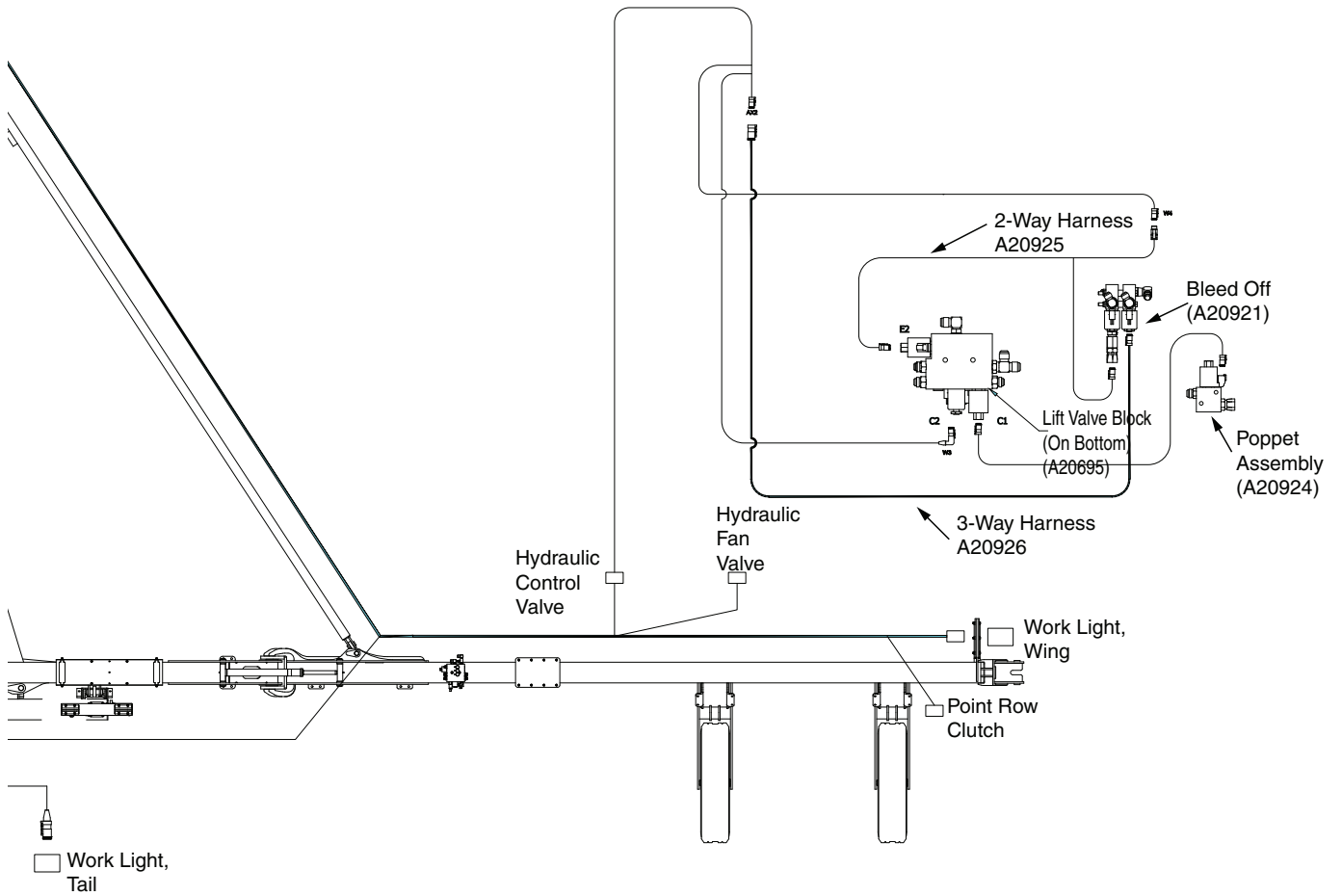

WIRING HARNESS SCHEMATIC ADVANCED ISOBUS

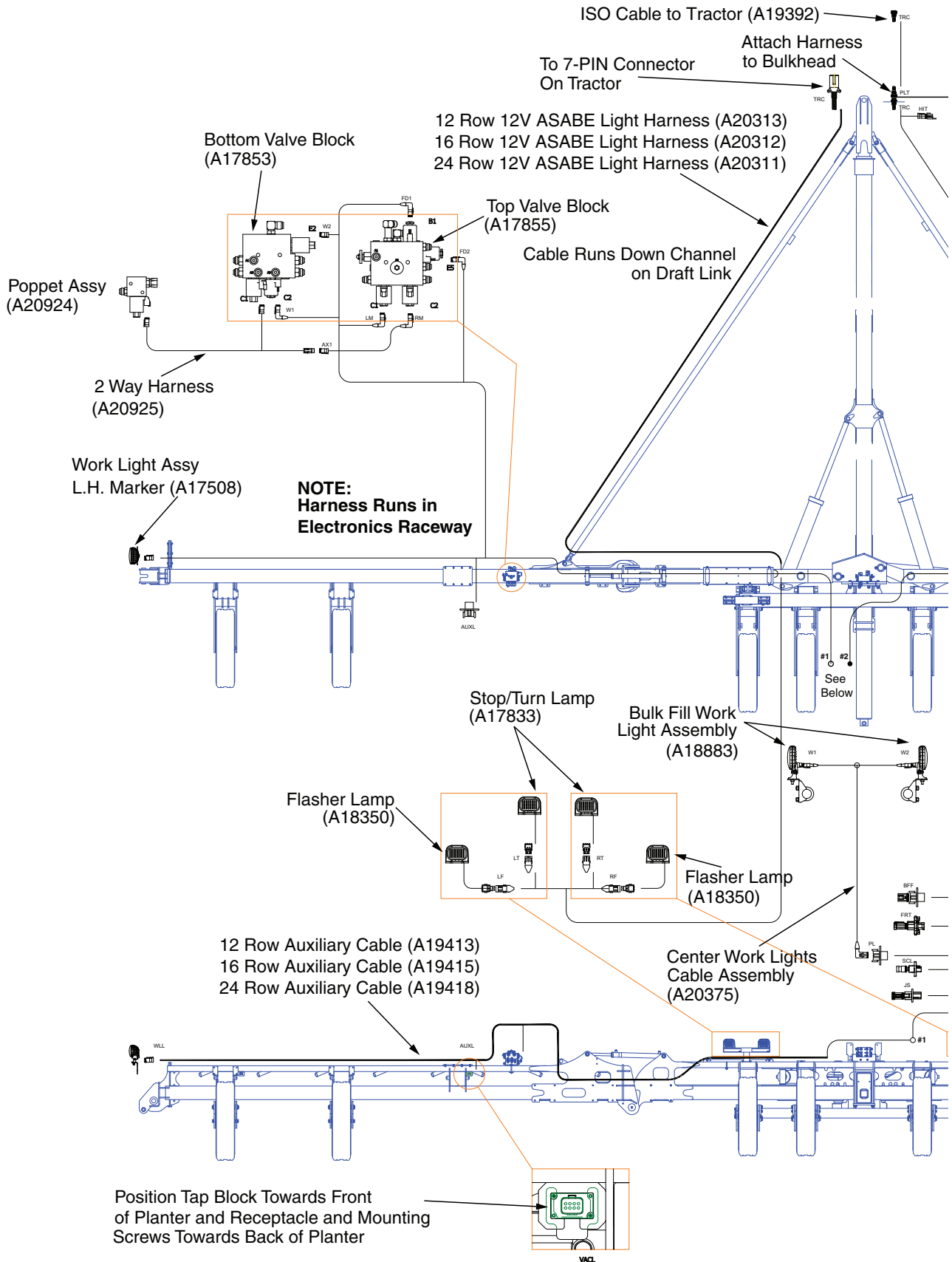

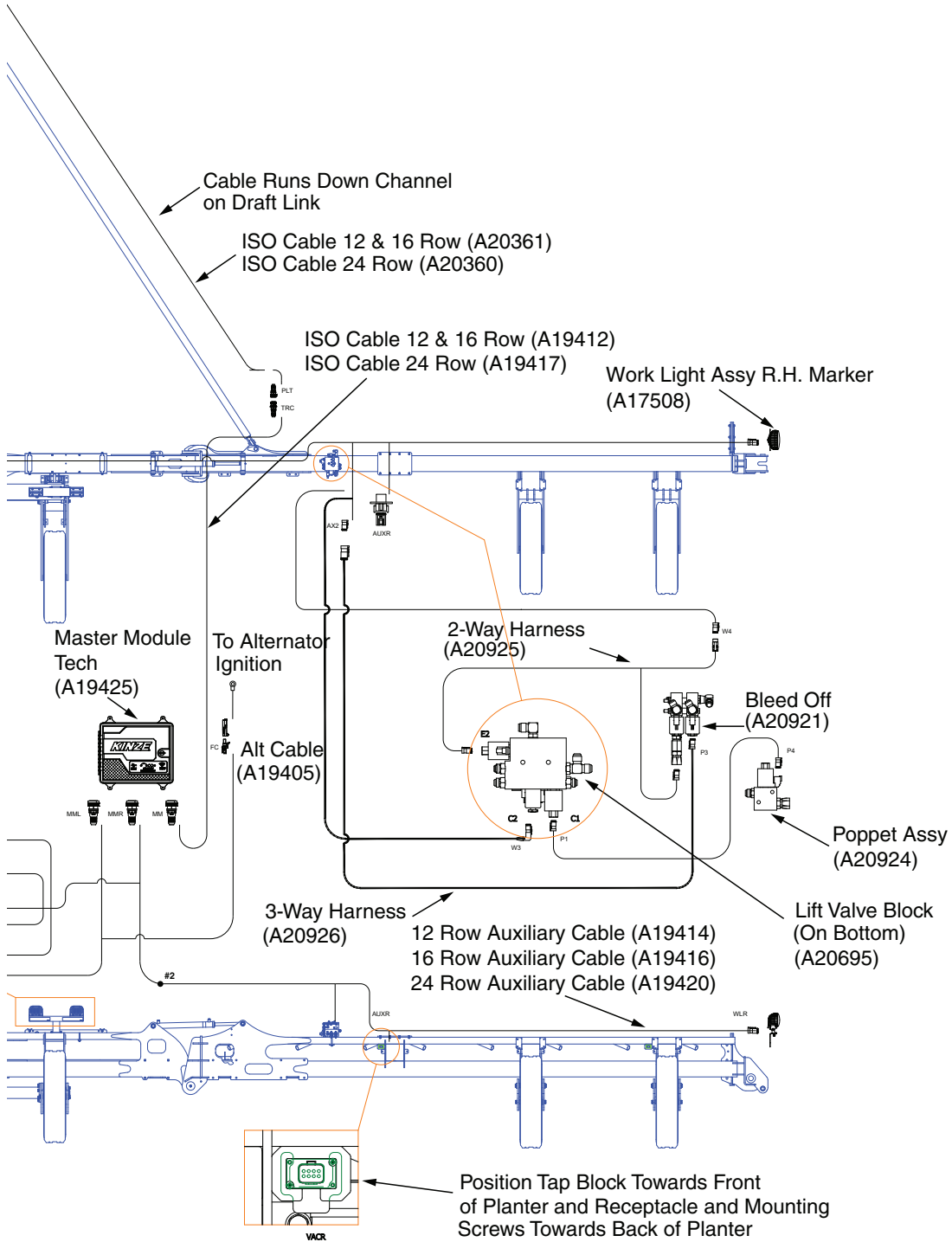

ELECTRICAL WIRING DIAGRAM - ADVANCED ISOBUS

NOTE: Light packages supplied on Model 4900 Front Folding Planters meet ASABE Standards. Check with tractor manufacturer for correct wiring harness to be wired into lights on your tractor.

*Optional customer-supplied auxiliary lights and wires may be wired into existing plug terminals.

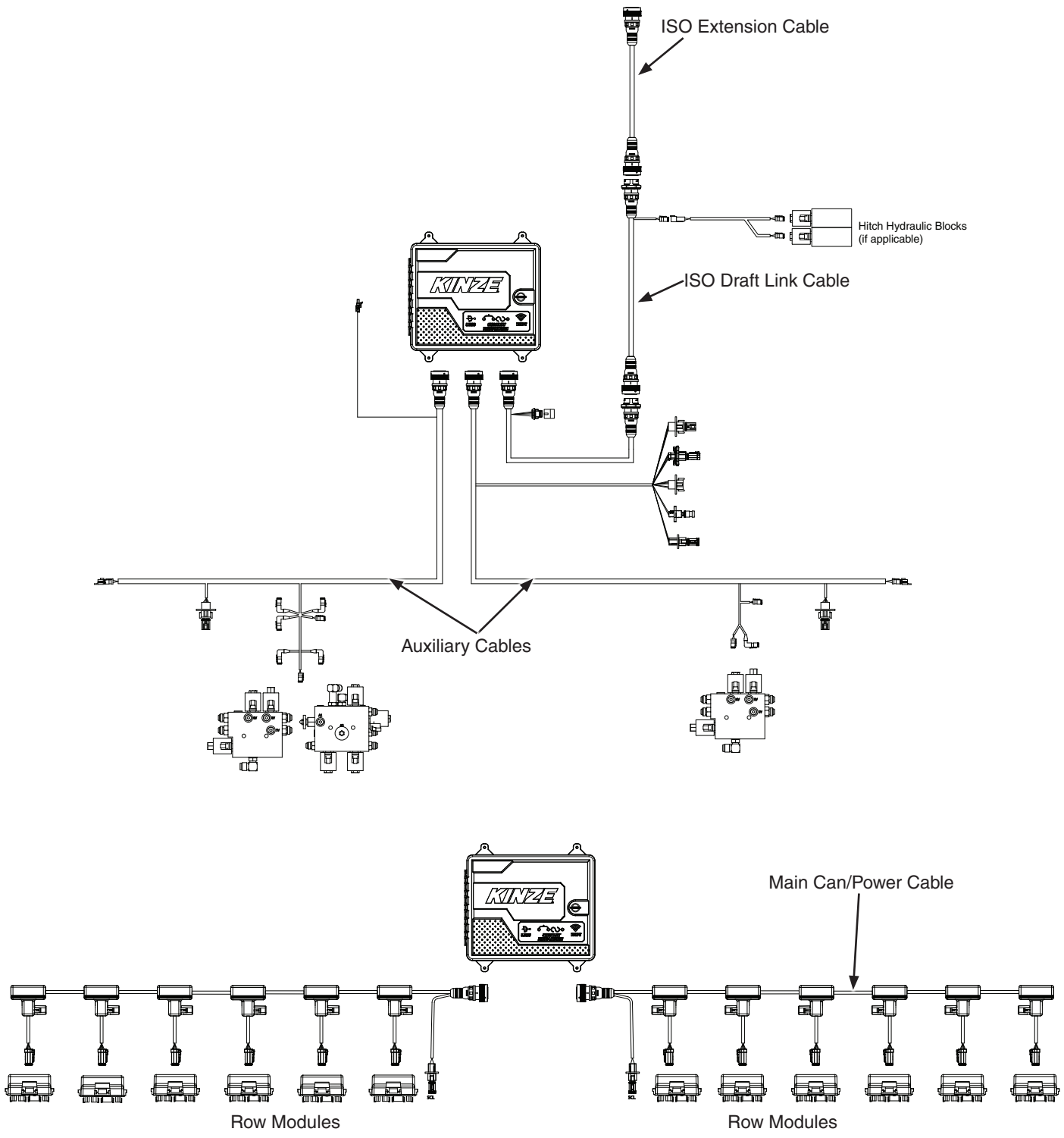

ELECTRICAL WIRING DIAGRAM - KPM III

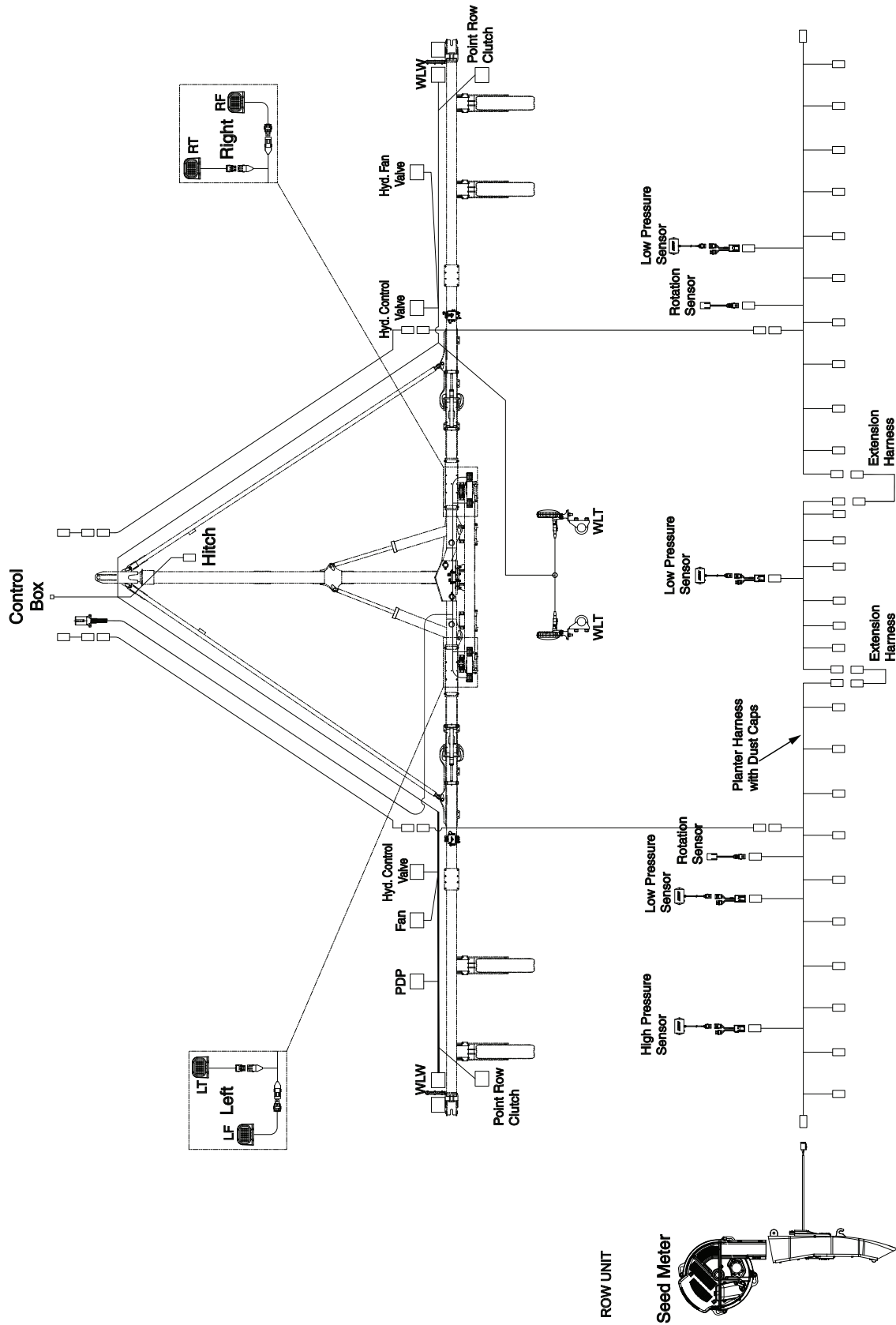

ELECTRICAL WIRING DIAGRAM - ISOBUS

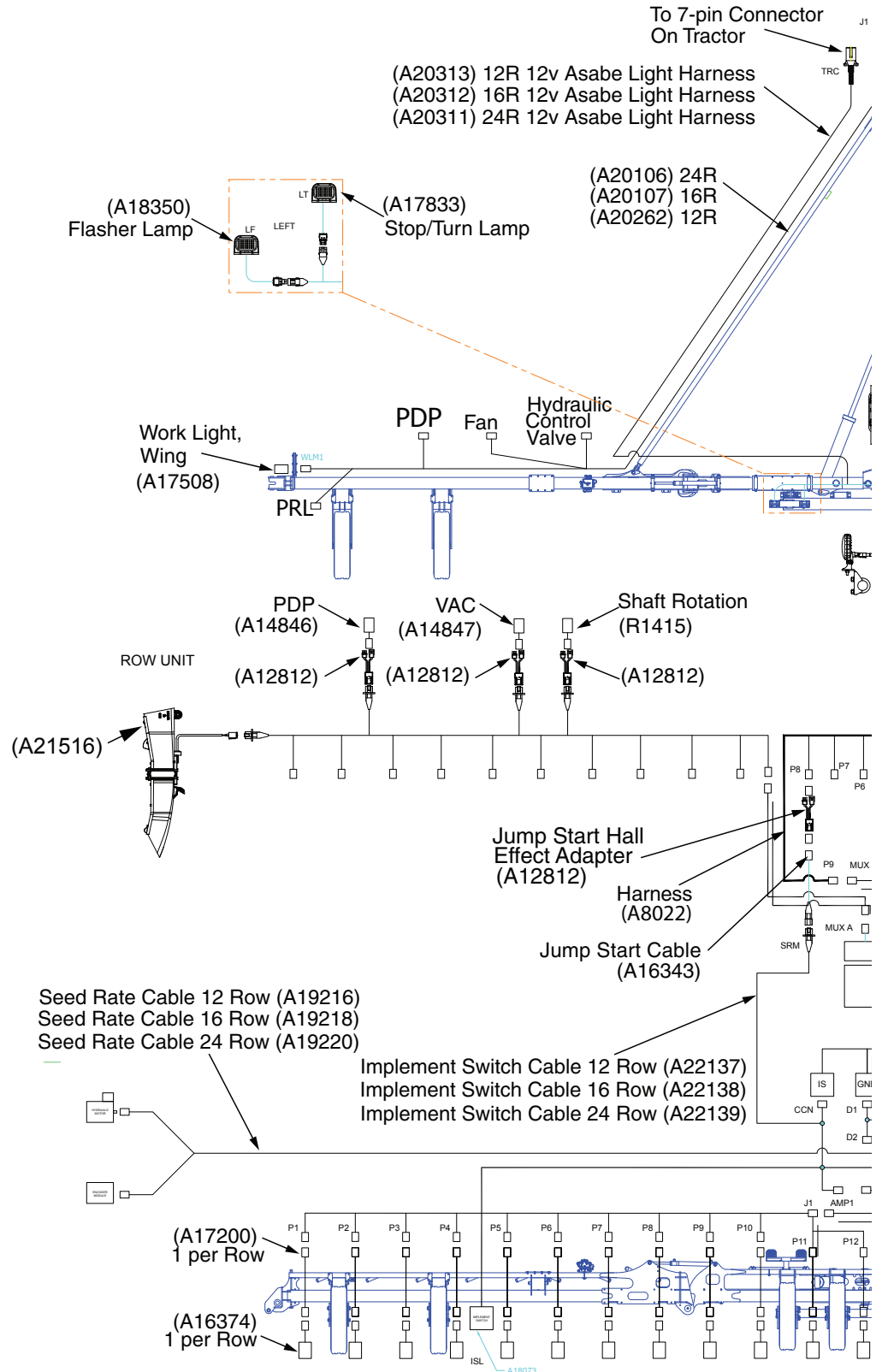

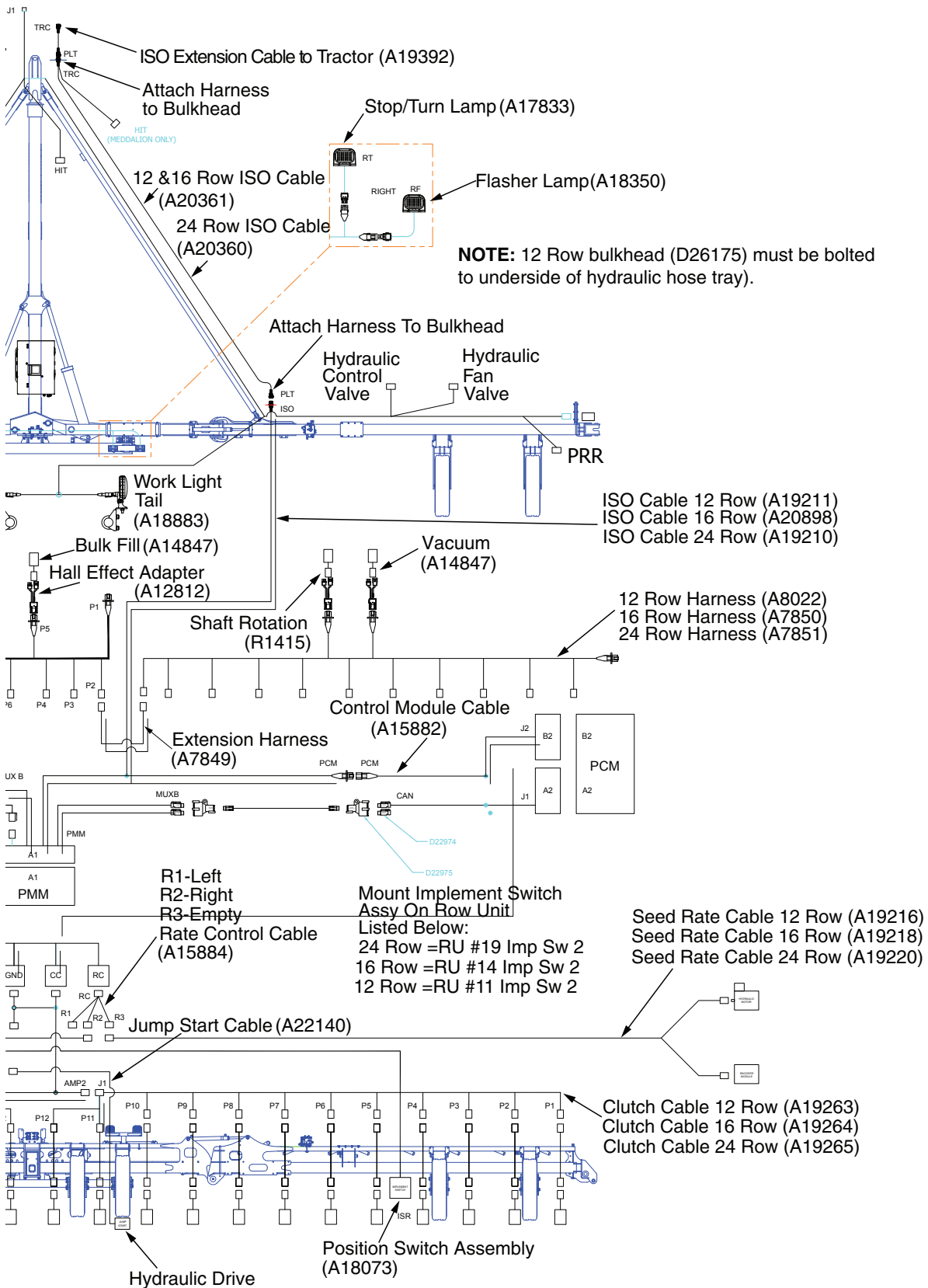

BASE MACHINE OPTIONS WIRING DIAGRAM

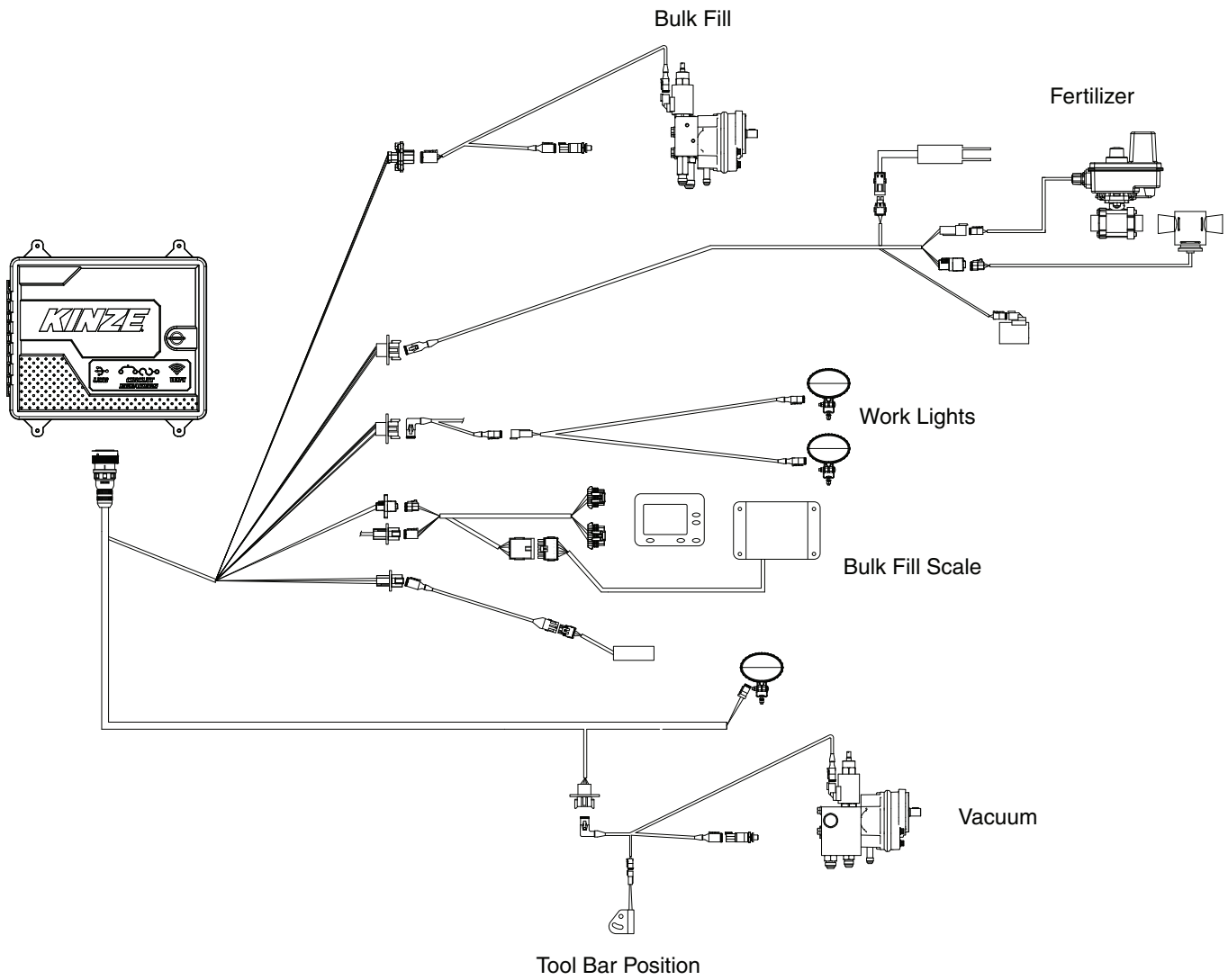

ROW UNIT HARNESS DIAGRAM

Row Unit Electric Drive

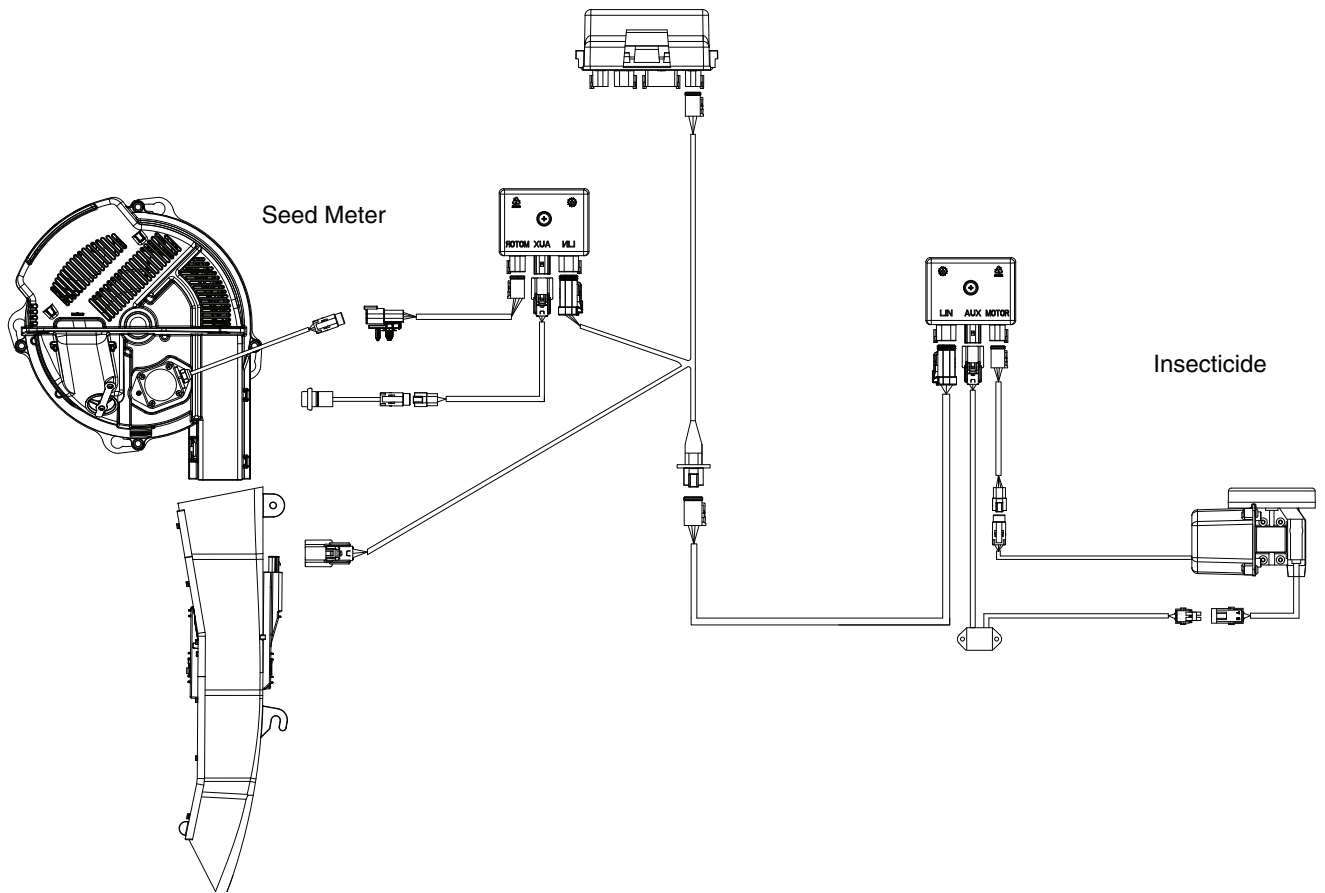

ELECTRICAL CONTROL CONSOLE SCHEMATIC - ADVANCED ISOBUS

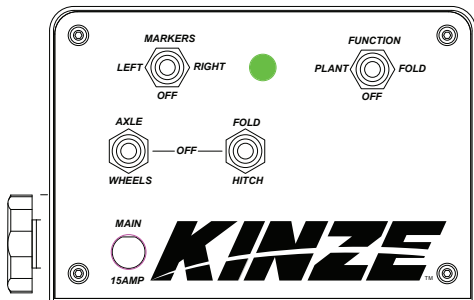
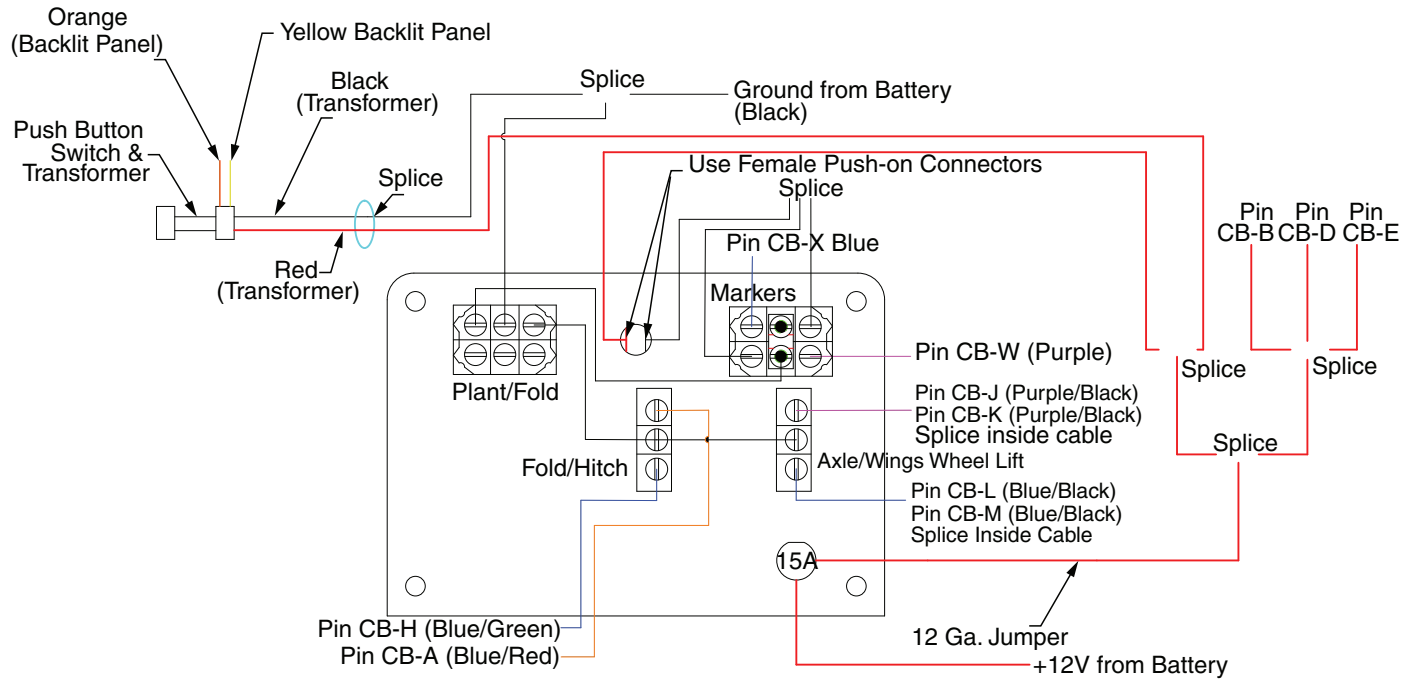

Wire Hookup Chart

Gauge	Color	Function
10	Red	Solenoid Power (12V)
10	Red	Solenoid Power (12V)
10	Red	Solenoid Power (12V)
16	Blue/Black	Axle
16	Purple/Black	Wing Wheels Right/Left
16	Purple	Right Marker
16	Blue/Green	Fold
16	Blue/Red	Hitch

NOTE: Operating marker in either direction lights panel light.

ELECTRICAL CONTROL CONSOLE CONNECTIONS - ISOBUS

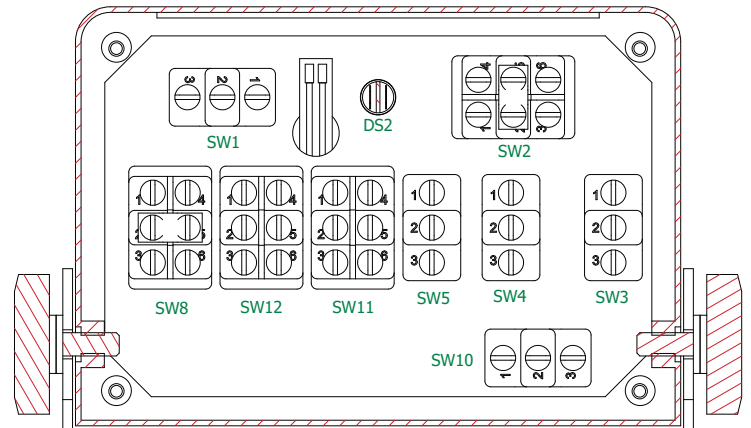
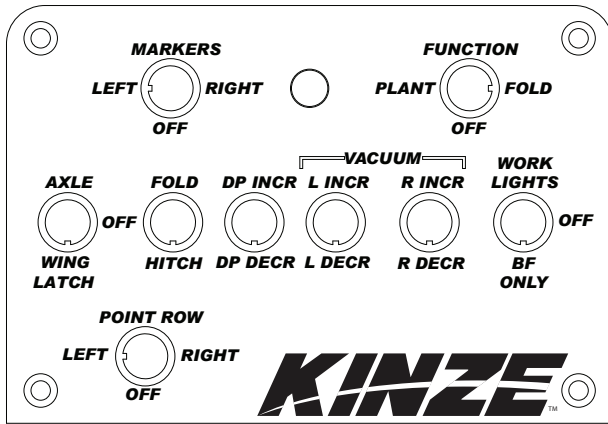

Wire Hookup Chart

Reference Designator	From	To	Color	Function
JP1	SW2-2	SW2-5		Jumper 1
JP2	SW8-2	SW8-5		Jumper 2
W1	E1	SW2-1	Orange	Marker Left
	E2	SW2-3	White/Orange	Marker Right
	E3	SW3-3	Brown	Axle
	E4	SW3-1	White/Brown	Wing Wheels
	E5	SW4-3	Gray	Fold
	E6	SW4-1	White/Gray	Hitch
	E7	SW5-3	Green	PDP Increase
	E8	SW5-1	White/Green	PDP Decrease
	W9	TB4	Blue	L VAC Increase
	W10	TB5	White/Blue	L VAC Increase
	W11	TB6	Violet	R VAC Increase
	W12	TB7	White/Violet	R VAC Decrease
	E13	SW8-3	Yellow	Work Light - Tank
	E14	SW8-6	White/Yellow	Work Light - Marker
	E15	SW10-1	Pink	Point Row L
	E16	SW10-3	White/Pink	Point Row R
	W15	TB2	Black	Tractor Ground
	W16	TB2	Black	Tractor Ground
W17W2	TB2	Black	Tractor Ground	
W18	TB1	Red	Tractor Power	
W2	SW3-2	SW4-2	Red	Jumper Wire
W3	SW8-5	SW12-2	Red	Jumper Wire
W4	SW11-2	SW12-2	Red	Jumper Wire

(Continued on next page)

Wire Hookup Chart (Continued)

Reference Designator	From	To	Color	Function
W5	SW5-2	SW11-2	Red	Jumper Wire
W6	SW8-1	SW8-3	Red	Jumper Wire
W7	SW1-3	SW2-5	Red	Jumper Wire
W8	SW1-1	SW4-2	Red	Jumper Wire
W9	SW1-2	TB1	Red	Tractor Power
W10	SW8-2	TB1	Red	Tractor Power
W11	SW2-4	TB3	Red	Marker LED
W12	SW2-6	TB3	Red	Marker LED
W13	DS2(+)	TB3	Red	Marker LED
W14	DS2(-)	SW12-5	Black	Tractor Ground
W15	SW10-2	TB1	Red	Tractor Power
W16	SW11-3	TB4	Blue	L VAC Increase
W17	SW11-4	TB4	Blue	L VAC Increase
W18	SW11-1	TB5	White/ Blue	L VAC Decrease
W19	SW11-6	TB5	White/ Blue	L VAC Decrease
W20	SW12-3	TB6	Violet	R VAC Increase
W21	SW12-4	TB6	Violet	R VAC Increase
W22	SW12-1	TB7	White/ Violet	R VAC Decrease
W23	SW12-6	TB7	White/ Violet	R VAC Decrease
W24	SW11-5	TB2	Black	Tractor Ground
W25	SW11-5	SW12-5	Black	Jumper Wire
U1	Red	TB1	Red	Tractor Power
	Black	TB2	Black	Tractor Ground
	Yellow	DS1-1	Yellow	Display Light
	Orange	DS1-2	Orange	Display Light

ADVANCED ISOBUS EXTENSION CABLE

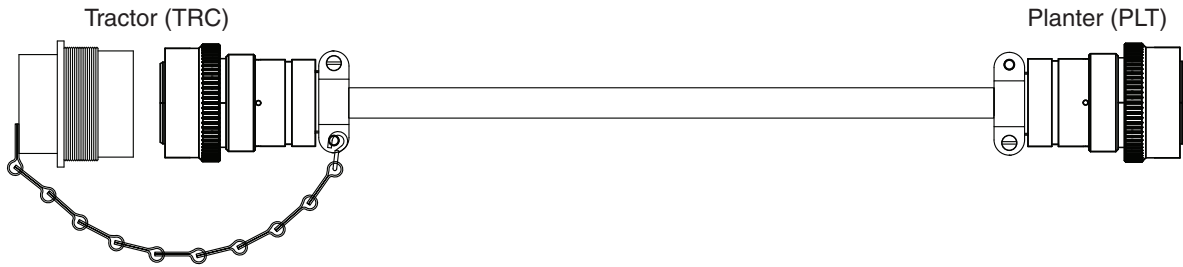

P/N A19392

Signal	Wire Gauge	Color	TRC	PLT
ECU Power (12V DC)	14	Red/Orange	4	B
Dirty Tractor Power (12V DC)	10	Red	3	G
Dirty Tractor Ground	10	Black	1	E
ECU Ground	14	Black/Orange	2	D
ISOBUS Can High	18 TQ	Yellow	8	S
ISOBUS Can Low	18 TQ	Green	9	T
TBC Power	18 TQ	Red	6	J
TBC Ground	18 TQ	Black	7	K

DRAWBAR HITCH CABLE

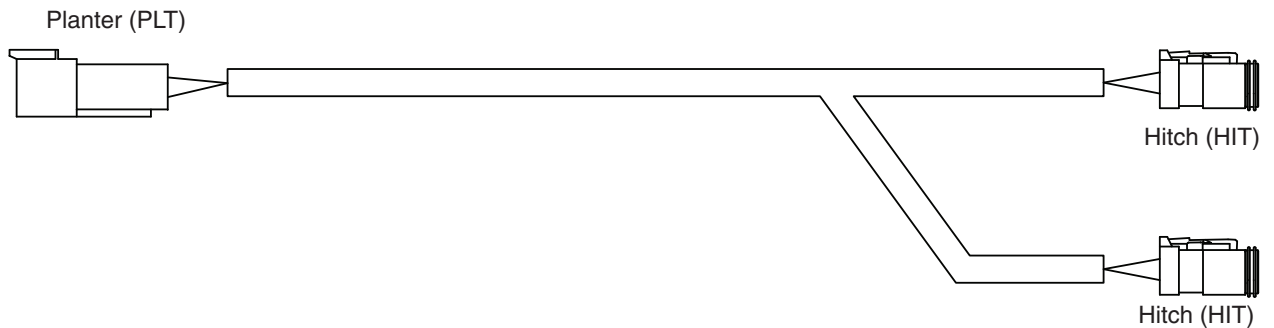

P/N A18712

Signal	Wire Gauge	Color	PLT	HIT
Power	16	Red	1	1
Ground	16	Blue/Red	2	2

LIGHTS CABLE

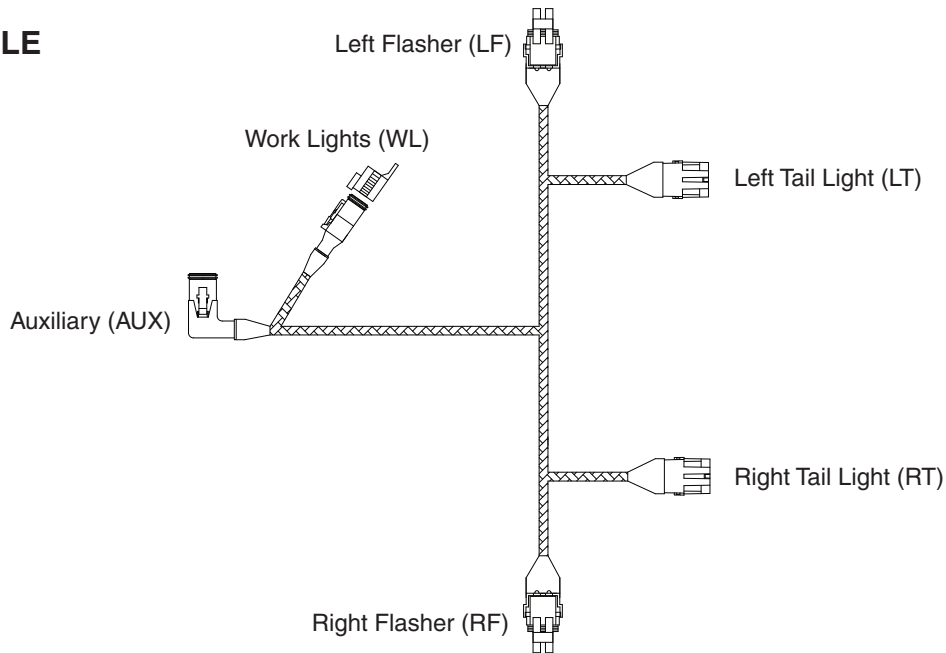

P/N A19397

Signal	Wire Gauge	Color	AUX	LF	LT	RF	RT	WL
Power WL (12V DC)	16	Red/White	1	-	-	-	-	2
Power TL (12V DC)	16	Red/Black	2	B	C	B	C	-
Tail Light	16	Brown	8	-	A	-	A	-
Left Flasher	16	Yellow	6	A	-	-	-	-
Right Flasher	16	Green	7	-	-	A	-	-
Work Lights	16	Gray	4	-	-	-	-	1

ADVANCED ISO PLANTER CABLE

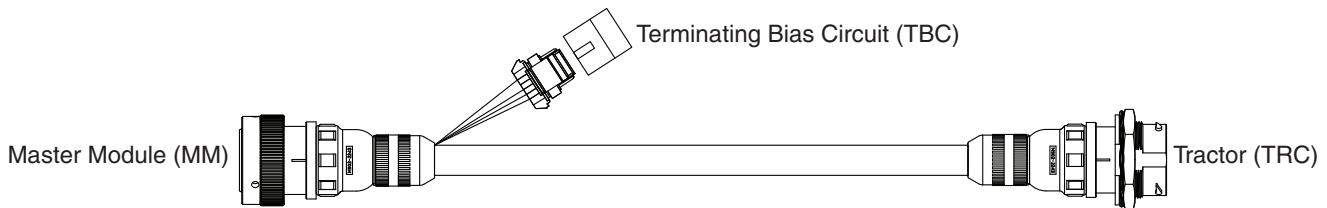

P/N A19412

Signal	Wire Gauge	Color	MM	TBC	TRC
ECU Power (12V DC)	14	Red/Orange	B	-	B
Dirty Tractor Power (12V DC)	10	Red	G	-	G
Solenoid Power (12V DC)	16	Red/Blue	W	-	W
Dirty Tractor Ground	10	Black	E	-	E
ECU Ground	14	Black/Orange	D	-	D
ISOBUS Can High	18 TQ	Yellow	S	E	S
ISOBUS Can Low	18 TQ	Green	T	F	T
TBC Power	18 TQ	Red	-	B	J
TBC Ground	18 TQ	Black	-	D	K
Hitch	16	Blue/Red	P	-	P

ISOBUS IMPLEMENT CABLE



Signal	ISO	Wire/Color	PMM	TBC	PCM	CAN	Mux A	Mux B
TBC Power	6	Twisted Quad Red	-	B	-	-	-	-
TBC Ground	7	Twisted Quad Black	-	D	-	-	-	-
ISO CAN H	8	Twisted Quad Yellow	31	E	-	-	-	-
ISO CAN L	9	Twisted Quad Green	32	F	-	-	-	-
ECU Power	4	Red	4, 5, 8	-	11	-	-	-
ECU Ground	2	Black	14, 15	-	12	-	-	-
LOAD Power	3	Red	-	-	1, 2, 3, 4	-	-	-
LOAD Ground	1	Black	-	-	5, 6, 7, 8	-	-	-
MUX A Power	-	Jacketed 3-Cond White	12	-	-	-	A	-
MUX A Ground	-	Jacketed 3-Cond Black	3	-	-	-	B	-
MUX A Signal	-	Jacketed 3-Cond Green	28	-	-	-	C	-
PROP CAN H	-	Twisted Pair Yellow	34	-	-	1	-	-
PROP CAN L	-	Twisted Pair Green	35	-	-	2	-	-
MUX B Power	-	Jacketed 3-Cond White	23	-	-	-	-	A
MUX B Ground	-	Jacketed 3-Cond Black	26	-	-	-	-	B
MUX B Signal	-	Jacketed 3-Cond Green	7	-	-	-	-	C

ISOBUS CAN JUMPER CABLE

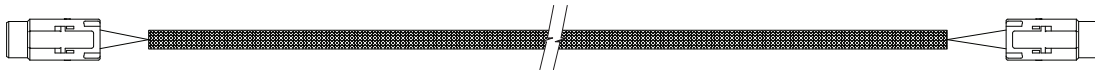

Signal	CAN	Wire/Color
CAN H	1	Twisted Pair Yellow
CAN L	2	Twisted Pair Green

PRODUCT CONTROL MODULE CABLE

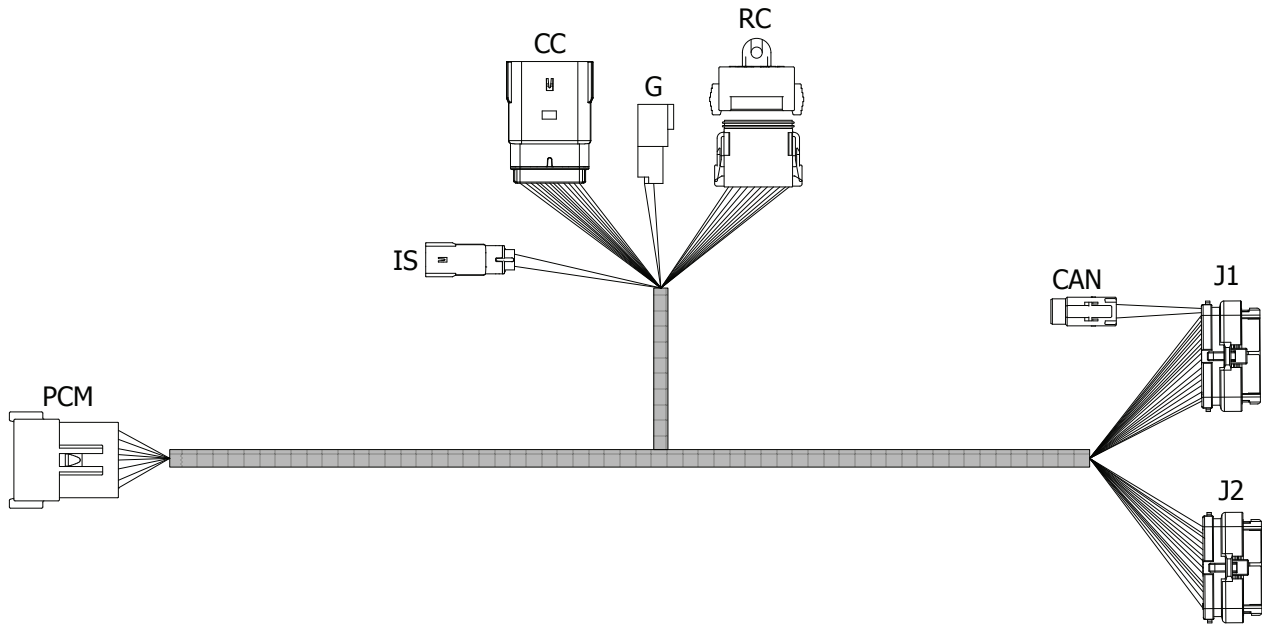

Signal	PCM	Wire/Color	J1	J2	CAN	RC	CC	IS	G
Load Power	1	Red	2	-	-	-	-	-	-
Load Power	2	Red	3	-	-	1	-	-	-
Load Power	3	Red	4	-	-	-	-	-	-
Load Power	4	Red	5	-	-	-	-	1	-
Load Ground	5	Black	-	-	-	-	-	-	1, 2
Load Ground	6	Black	14, 15	-	-	-	-	-	-
Load Ground	7	Black	16	-	-	2	-	-	-
Load Ground	8	Black	17	-	-	-	-	-	-
ECU Power	11	White/Red	11	-	-	-	-	-	-
CAN H	-	Twisted Pair Yellow	34	-	1	-	-	-	-
CAN L	-	Twisted Pair Green	33	-	2	-	-	-	-
Switch In	-	Red/Green	10	-	-	-	-	2	-
Section 1	-	White	24	-	-	-	1	-	-
Section 2	-	Green	25	-	-	-	2	-	-
Section 3	-	Orange	26	-	-	-	3	-	-
Section 4	-	Blue	27	-	-	-	4	-	-
Section 5	-	Brown	-	11	-	-	5	-	-
Section 6	-	Yellow	-	10	-	-	6	-	-
Section 7	-	Violet	-	9	-	-	7	-	-
Section 8	-	Gray	-	8	-	-	8	-	-
Section 9	-	Pink	-	7	-	-	9	-	-
Section 10	-	Tan	-	6	-	-	10	-	-
Section 11	-	Red/Green	-	5	-	-	11	-	-
Section 12	-	Black/Red	-	4	-	-	12	-	-
PWM 1 Power	-	Red/White	-	23	-	3	-	-	-
PWM 1 Ground	-	Black/White	35	-	-	4	-	-	-
PWM 2 Power	-	Red/Yellow	-	12	-	5	-	-	-
PWM 2 Ground	-	Black/Yellow	12	-	-	6	-	-	-
PWM 3 Power	-	Red/Blue	1	-	-	7	-	-	-
PWM 3 Ground	-	Black/Blue	-	24	-	8	-	-	-
Meter Speed 1	-	Green	30	-	-	9	-	-	-
Meter Speed 2	-	Green/White	29	-	-	10	-	-	-
Meter Speed 3	-	Green/Red	-	33	-	11	-	-	-

ISOBUS IMPLEMENT SWITCH EXTENSION CABLE

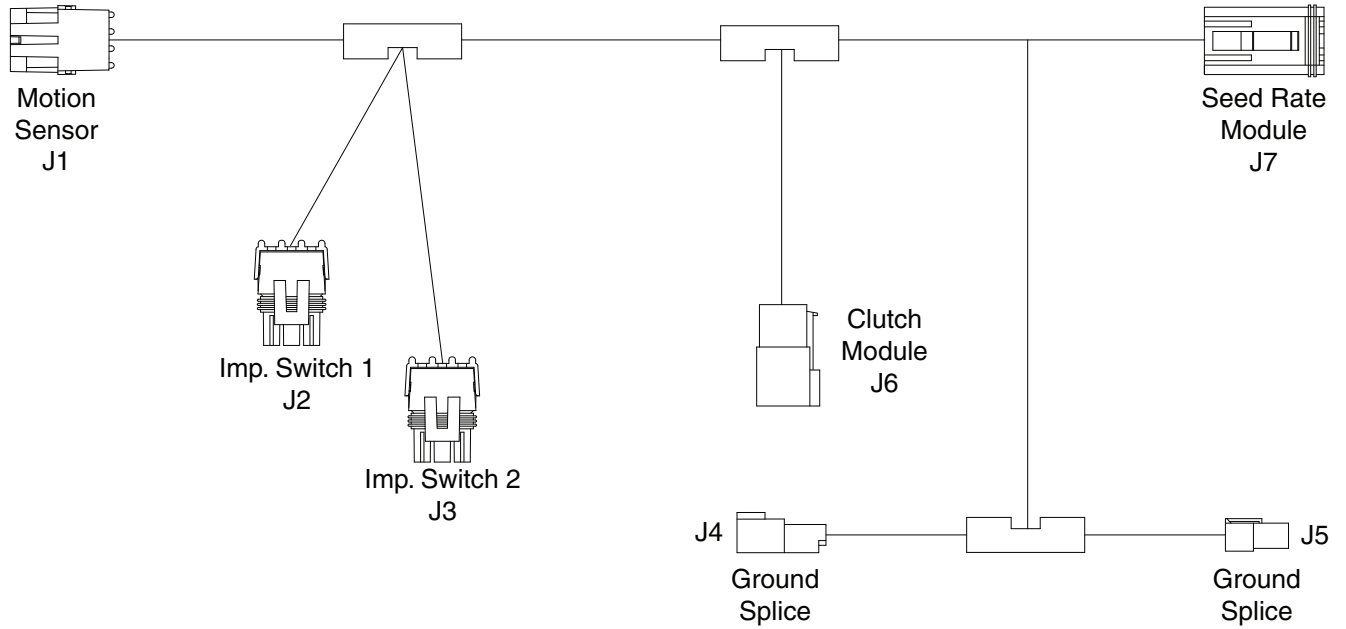

Signal	Imp. Switch 1 WP Tower 1	Imp. Switch 2 WP Tower 2	Motion Sensor WP Shroud	Color	Clutch Module Molex Recept	Seed Rate Module Deutsch Plug	Ground Splice 1	Ground Splice 2	Gauge
12V+ Power	A	A	-	Brown	1	12	-	-	16
Switch Signal	B	B	-	Green	2	10	-	-	16
Motion Signal	-	-	C	White	-	11	-	-	16
Ground	-	-	B	Black	-	6	-	-	16
12V+ Power	-	-	A	Red	-	1	-	-	16
Ground	C (Blue 16 AWG)	C (Blue 16 AWG)	-	Black	-	-	2	2	12
12V+ Power	-	-	-	Red	-	-	1	1	12

ISOBUS SECTION ADAPTER CABLE - 12 ROW

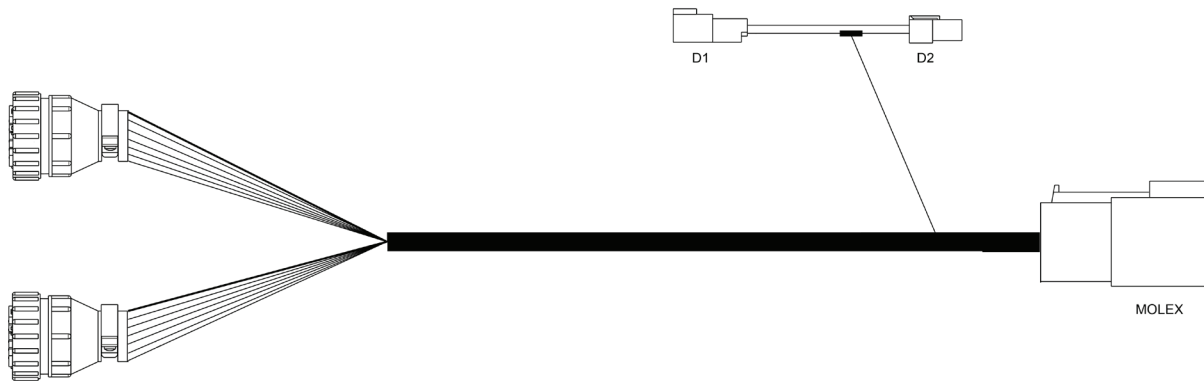

Signal	Color	AMP 1 (Left)	AMP 2 (Right)	Molex	D1	D2
High Current Power	Red	1 (16 Gauge)	1 (16 Gauge)	-	1 (12 Gauge)	1 (12 Gauge)
Ground	Black	-	-	-	2	2
Row 1, 2	Black	2, 3	-	1	-	-
Row 3, 4	Brown	4, 5	-	2	-	-
Row 5, 6	Orange	6, 7	-	3	-	-
Row 7, 8	Pink	-	6, 7	4	-	-
Row 9, 10	Green	-	4, 5	5	-	-
Row 11, 12	Yellow	-	2, 3	6	-	-

ISOBUS SECTION ADAPTER CABLE - 16 ROW

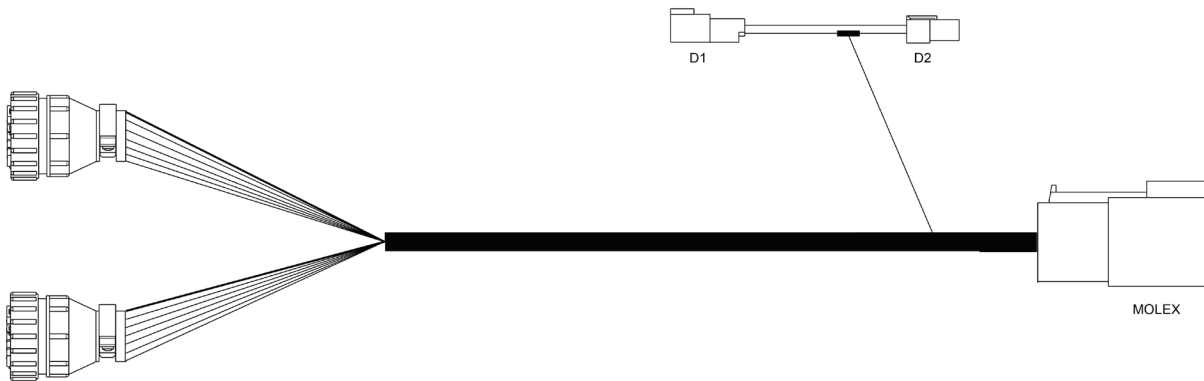

Signal	Color	AMP 1 (Left)	AMP 2 (Right)	Molex	D1	D2
High Current Power	Red	1 (16 Gauge)	1 (16 Gauge)	-	1 (12 Gauge)	1 (12 Gauge)
Ground	Black	-	-	-	2	2
Row 1, 2	Black	2, 3	-	1	-	-
Row 3, 4	Brown	4, 5	-	2	-	-
Row 5, 6	Orange	6, 7	-	3	-	-
Row 7, 8	Pink	8, 9	-	4	-	-
Row 9, 10	Green	-	8, 9	5	-	-
Row 11, 12	Yellow	-	6, 7	6	-	-
Row 13, 14	Blue	-	4, 5	7	-	-
Row 15, 16	Violet	-	2, 3	8	-	-

ISOBUS CLUTCH CABLE - 12 ROW

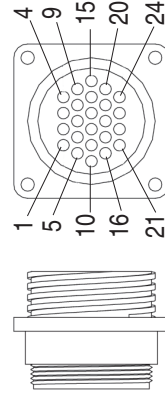
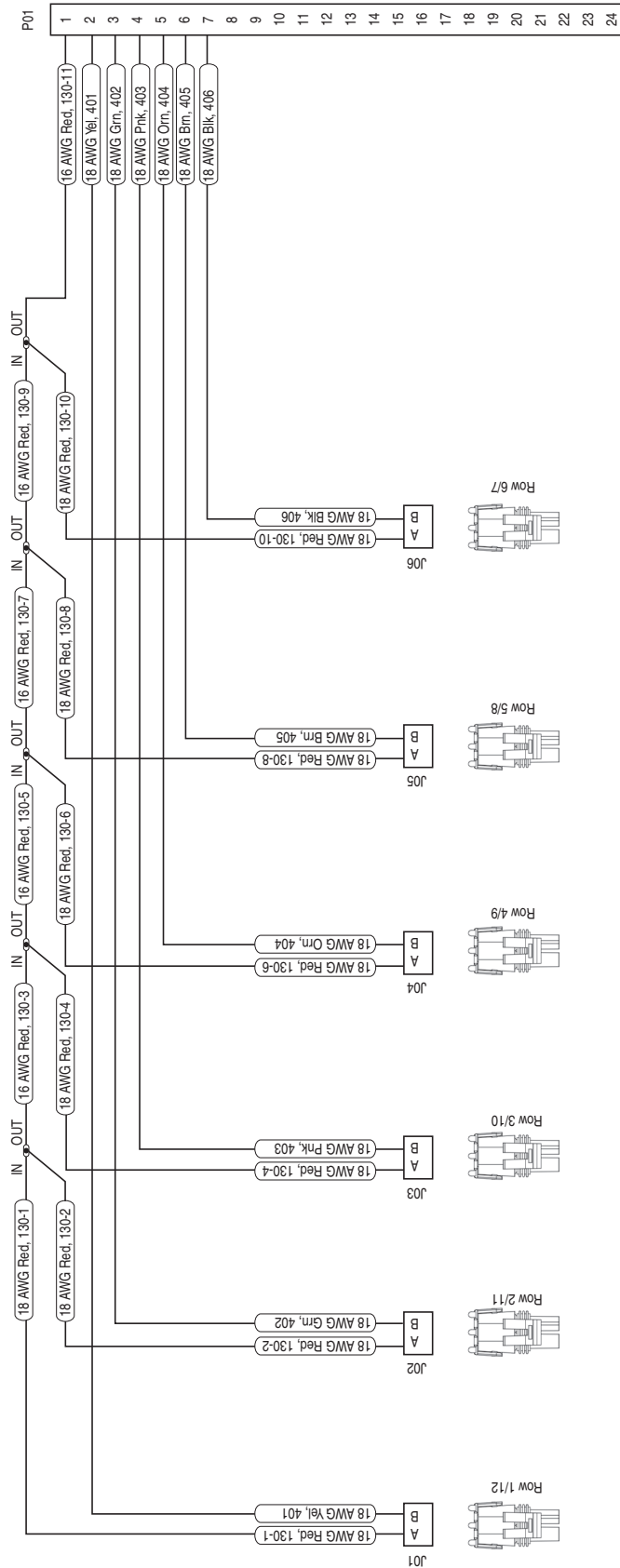

Clutch Module
Left/Right

Signal	Clutch Cable	Row 8/9	Row 7/10	Row 6/11	Row 5/12	Row 4/13	Row 3/14	Row 2/15	Row 1/16
Power	1	A	A	A	A	A	A	A	A
Row 1/16	2	-	-	-	-	-	-	-	B
Row 2/15	3	-	-	-	-	-	B	-	-
Row 3/14	4	-	-	-	-	B	-	-	-
Row 4/13	5	-	-	-	B	-	-	-	-
Row 5/12	6	-	-	-	-	B	-	-	-
Row 6/11	7	-	-	B	-	-	-	-	-
Row 7/10	8	-	B	-	-	-	-	-	-
Row 8/9	9	B	-	-	-	-	-	-	-

ISOBUS CLUTCH CABLE - 16 ROW

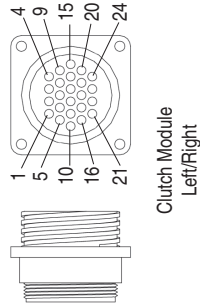
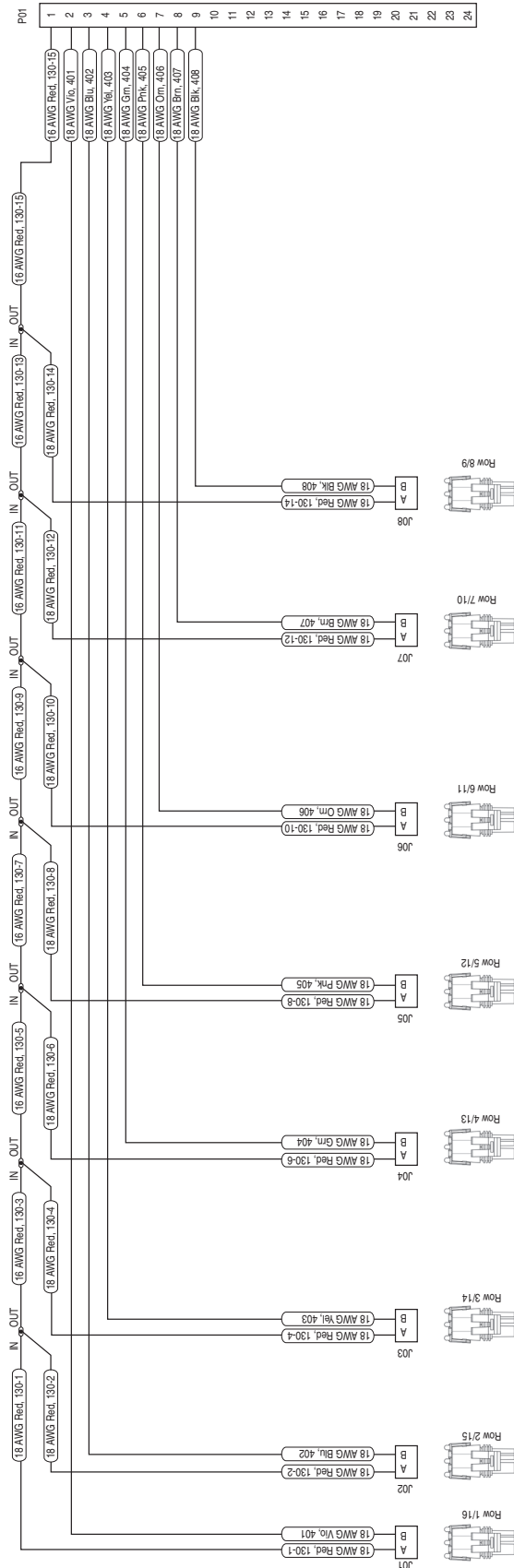

Signal	Clutch Cable	Row 8/9	Row 7/10	Row 6/11	Row 5/12	Row 4/13	Row 3/14	Row 2/15	Row 1/16
Power	1	A	A	A	A	A	A	-	-
Row 1/12	2	-	-	-	-	-	B	-	-
Row 2/11	3	-	-	-	-	B	-	-	-
Row 3/10	4	-	-	-	B	-	-	-	-
Row 4/9	5	-	-	B	-	-	-	-	-
Row 5/8	6	-	B	-	-	-	-	-	-
Row 6/7	7	B	-	-	-	-	-	-	-

RIGHT AUXILIARY CABLE

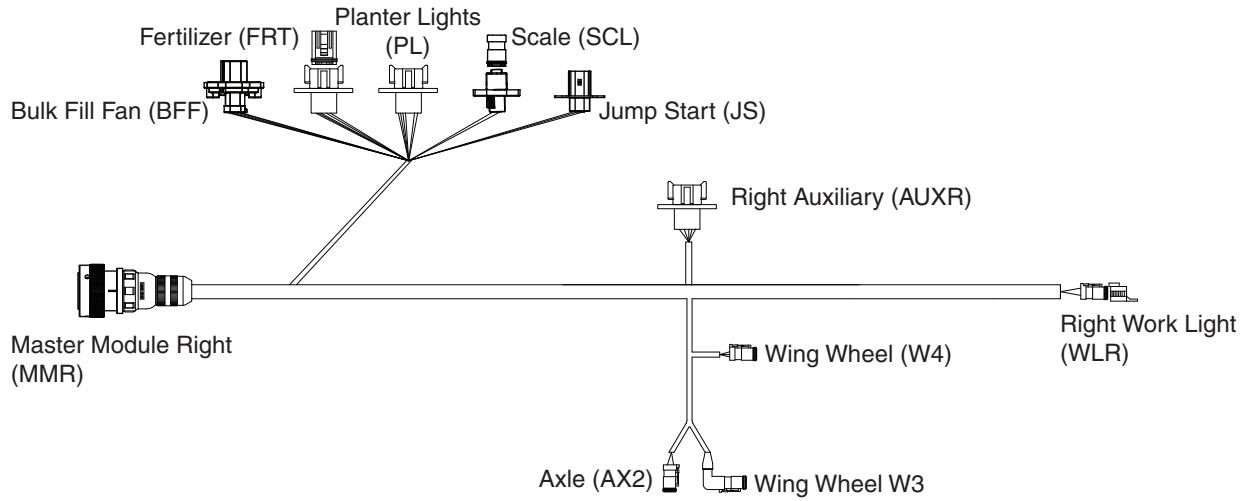

P/N A19414

Signal	Wire Gauge	Color	MMR	WLR	AUXR	W3	W4	AX2	JS	SCL	PL	FRT	BFF
Solenoid Power (12VDC)	10	Red	3	-	1	1	1	1	-	-	-	8	1
Worklight Power (12VDC)	14	Red/White	1	2	-	-	-	-	-	-	1	-	-
Tow Light Power (12VDC)	14	Red/Black	4	-	-	-	-	-	-	-	2	-	-
Sensor Supply +5VDC	16	White	7	-	3	-	-	-	-	-	-	-	-
Sensor Supply +12VDC	16	White/Red	8	-	6	-	-	-	1	1	-	4	4
Ground	10	Black	2	-	7	-	-	-	2	2	-	5	5
Fertilizer Rate+	16	Orange	21	-	-	-	-	-	-	-	-	1	-
Fertilizer Rate-	16	Green	22	-	-	-	-	-	-	-	-	2	-
Fertilizer Flow Signal	16	Blue	23	-	-	-	-	-	-	-	-	6	-
Fertilizer Tank Level	16	Green/White	24	-	-	-	-	-	-	-	-	3	-
Fertilizer On/Off	16	Yellow	25	-	-	-	-	-	-	-	-	7	-
Axle	16	Blue/Black	20	-	-	-	-	2	-	-	-	-	-
Wing Wheels Right	16	Purple/Black	10	-	-	2	2	-	-	-	-	-	-
Right Vac PWM	16	Pink	28	-	2	-	-	-	-	-	-	-	-
Right Vac Signal	16	Tan	29	-	8	-	-	-	-	-	-	-	-
Bulk Fill Fan PWM	16	Pink/Green	11	-	-	-	-	-	-	-	-	-	2
Bulk Fill Fan Signal	16	Tan/Green	12	-	-	-	-	-	-	-	-	-	6
Right Toolbar Position Signal	16	Green/Red	6	-	4	-	-	-	-	-	-	-	-
Jump Start Signal	16	Green/Yellow	5	-	-	-	-	-	3	-	-	-	-
Tail Light	16	Brown/Black	19	-	-	-	-	-	-	-	8	-	-
Right Flasher	16	Green/Black	17	-	-	-	-	-	-	-	7	-	-
Left Flasher	16	Yellow/Black	16	-	-	-	-	-	-	-	6	-	-
Work Light Wing	16	Gray	14	1	-	-	-	-	-	-	-	-	-
Work Light Center	16	Gray/Black	15	-	-	-	-	-	-	-	4	-	-

LEFT AUXILIARY CABLE

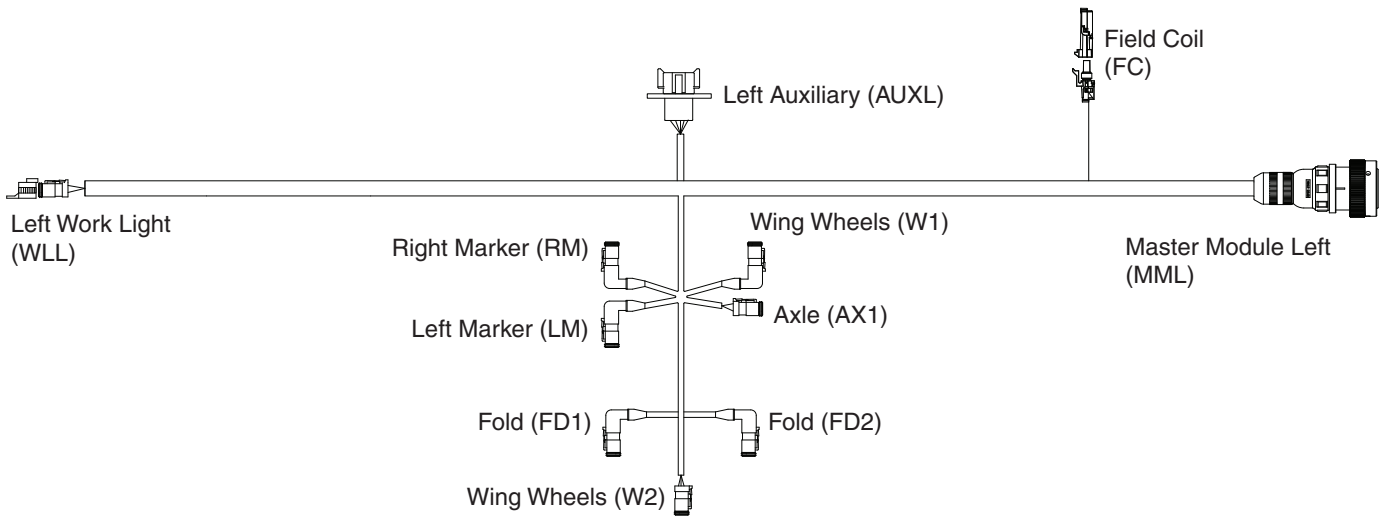

P/N A19413

Signal	Wire Gauge	Color	MML	WLL	AUXL	LM	RM	W1	W2	AX1	FD1	FD2	FC
Solenoid Power (12VDC)	10	Red/Blue	G	-	1	1	1	1	1	1	1	1	
Worklight Power (12VDC)	16	Red/White	H	2	-	-	-	-	-	-	-	-	-
Field Coil Power (12VDC)	14	Red/Yellow	D	-	-	-	-	-	-	-	-	-	A
Sensor Supply +5VDC	16	White	V	-	3	-	-	-	-	-	-	-	-
Sensor Supply +12VDC	16	White/Red	L	-	6	-	-	-	-	-	-	-	-
Ground	16	Black	T	-	7	-	-	-	-	-	-	-	-
Right Marker	16	Purple	J	-	-	-	2	-	-	-	-	-	-
Left Marker	16	Blue	X	-	-	2	-	-	-	-	-	-	-
Axle	16	Blue/Black	N	-	-	-	-	-	-	2	-	-	-
Wing Wheels Left	16	Purple/Green	C	-	-	-	-	2	2	-	-	-	-
Fold	16	Blue/Green	M	-	-	-	-	-	-	-	2	2	-
Left Vac PWM	16	Pink/Black	U	-	2	-	-	-	-	-	-	-	-
Left Vac Signal	16	Tan/Black	W	-	8	-	-	-	-	-	-	-	-
Left Toolbar Position Signal	16	Green/Blue	K	-	4	-	-	-	-	-	-	-	-
Work Light Wing	16	Gray	A	1	-	-	-	-	-	-	-	-	-

CAN POWER CABLE

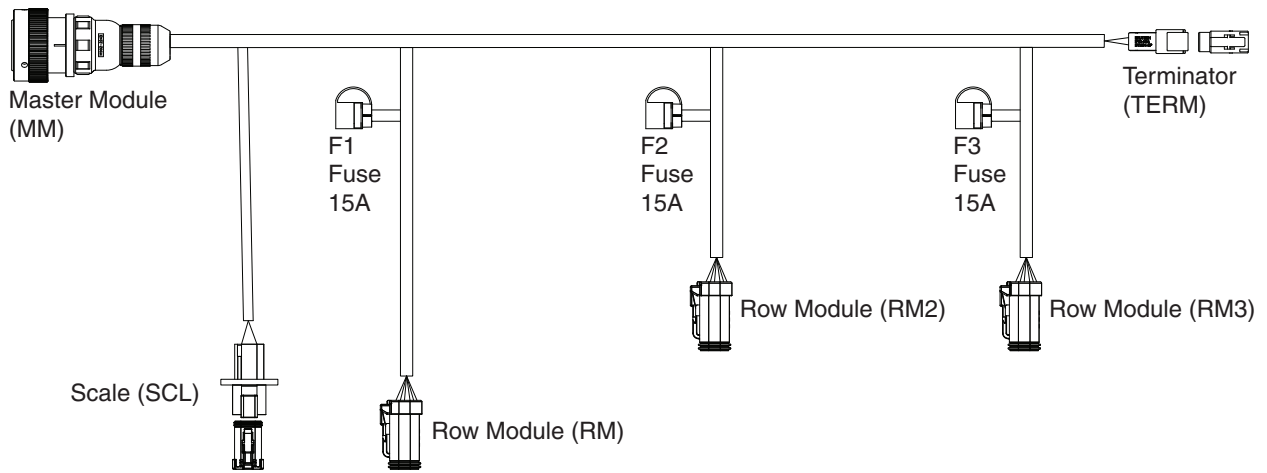

P/N A19396

Signal	Wire Gauge	Color	MM	SCL	F1	RM1	F2	RM2	F3	RM3	TERM
Power	8	Red	S	-	A	-	A	-	A	-	-
Ground	8	Black	U	-	-	3	-	3	-	3	-
Fused Power 1	16	Red/Yellow	-	-	B	4	-	-	-	-	-
Fused Power 2	16	Red/Yellow	-	-	-	-	B	4	-	-	-
Fused Power 3	16	Red/Yellow	-	-	-	-	-	-	B	4	-
CAN H	18 TP	Yellow	W	1	-	2	-	2	-	2	1
CAN L	18 TP	Green	V	2	-	5	-	5	-	5	2
RM Enable 1	16	Tan	-	-	B	1	-	-	-	-	-
RM Enable 2	16	Orange	-	-	-	6	-	1	-	-	-
RM Enable 3	16	Blue	-	-	-	-	-	6	-	1	-

ROW UNIT CABLE LIN

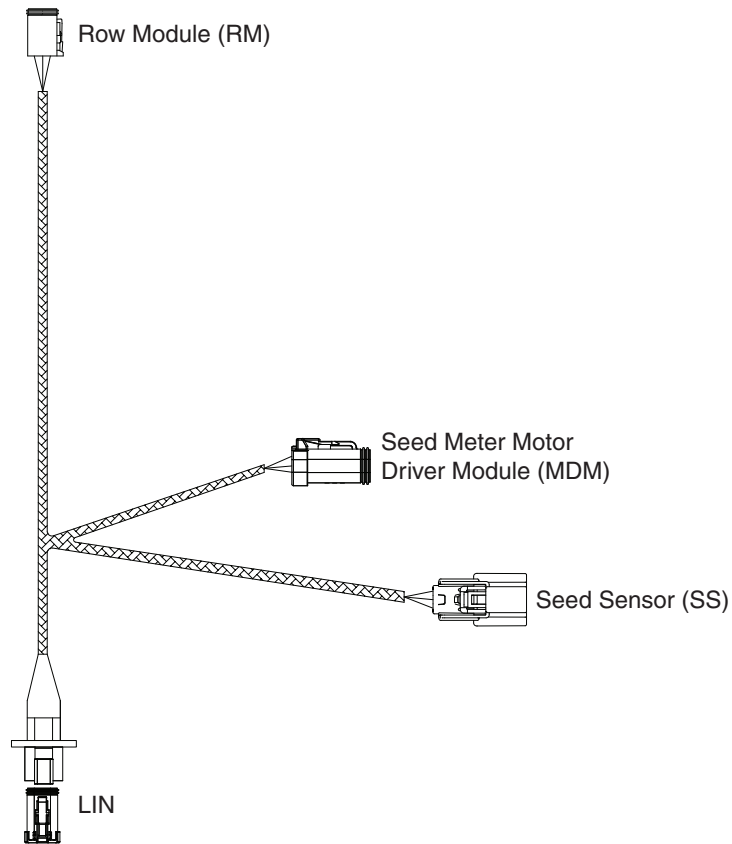

P/N A19399

Signal	Wire Gauge	Color	RM	MDM	SS	LIN
Power 24VDC	16	Red	3	1	-	3
Ground	16	Black	2	2	6	2
Power 12VDC	16	White	4	-	1	4
LIN	16	Blue	1	3	2	1

INSECTICIDE MOTOR CABLE

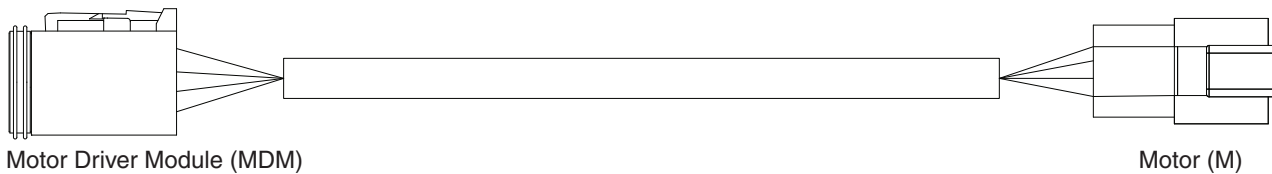

P/N A19402

Signal	Wire Gauge	Color	MDM	M
Coil 1A+	18	Red	1	1
Coil 1B-	18	White	2	2
Coil 2A+	18	Green	3	3
Coil 2B-	18	Black	4	4

INSECTICIDE COMMUNICATION CABLE

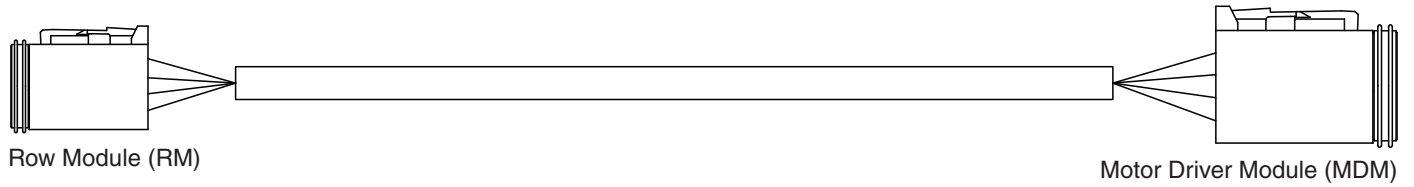

P/N A19403

Signal	Wire Gauge	Color	RM	MDM
Power 24VDC	16	Red	3	1,4
Ground	16	Black	2	2
LIN	16	Blue	1	3

MOTOR CABLE



P/N A19401

Signal	Wire Gauge	Color	MDM	SM
Coil 1A+	18	Red	1	1
Coil 1B-	18	White	2	2
Coil 2A+	18	Green	3	3
Coil 2B-	18	Black	4	4

FERTILIZER CONTROL CABLE

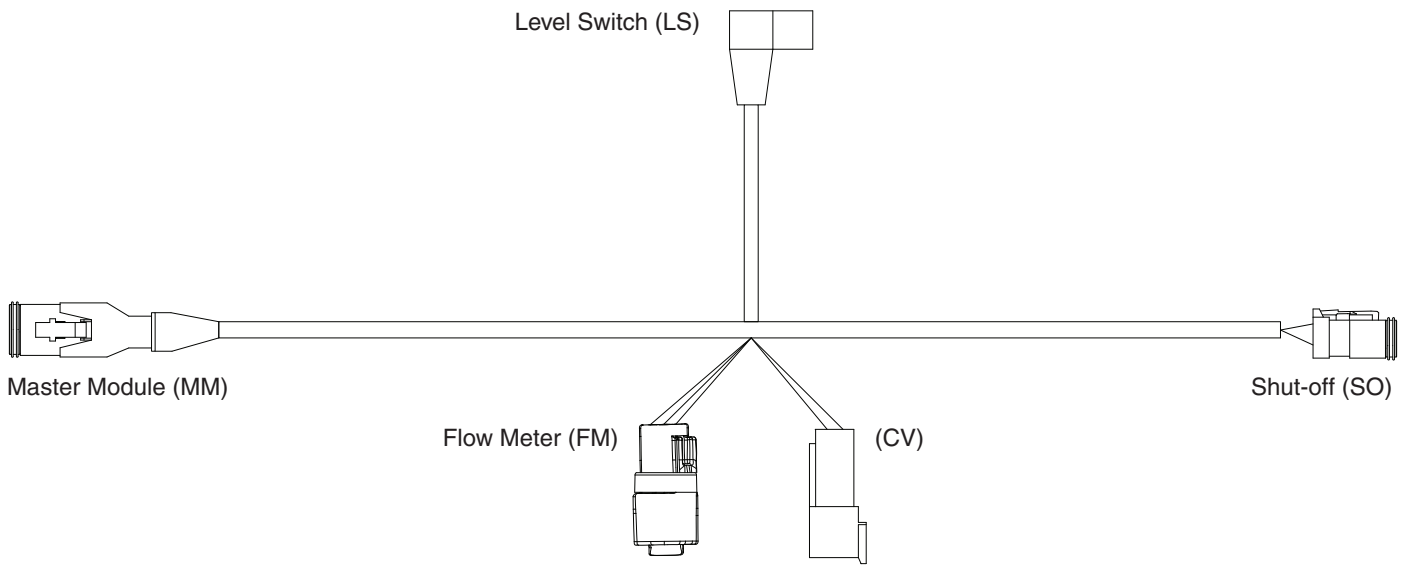

P/N A19421

Signal	Wire Gauge	Color	MM	LS	FM	SO	CV
Rate Increase	16	Orange/Red	1	-	-	-	1
Rate Decrease	16	Orange/Black	2	-	-	-	2
Sensor Supply 12VDC	16	Red/White	4	1	A	-	-
Ground	16	Black	5	3	C	-	-
Flow Meter Signal	16	Green	6	-	B	-	-
Level Switch	16	White	3	4	-	-	-
Solenoid Power	16	Red	8	-	-	1	-
Shut-off	16	Yellow	7	-	-	2	-

FERTILIZER OPTION CABLE

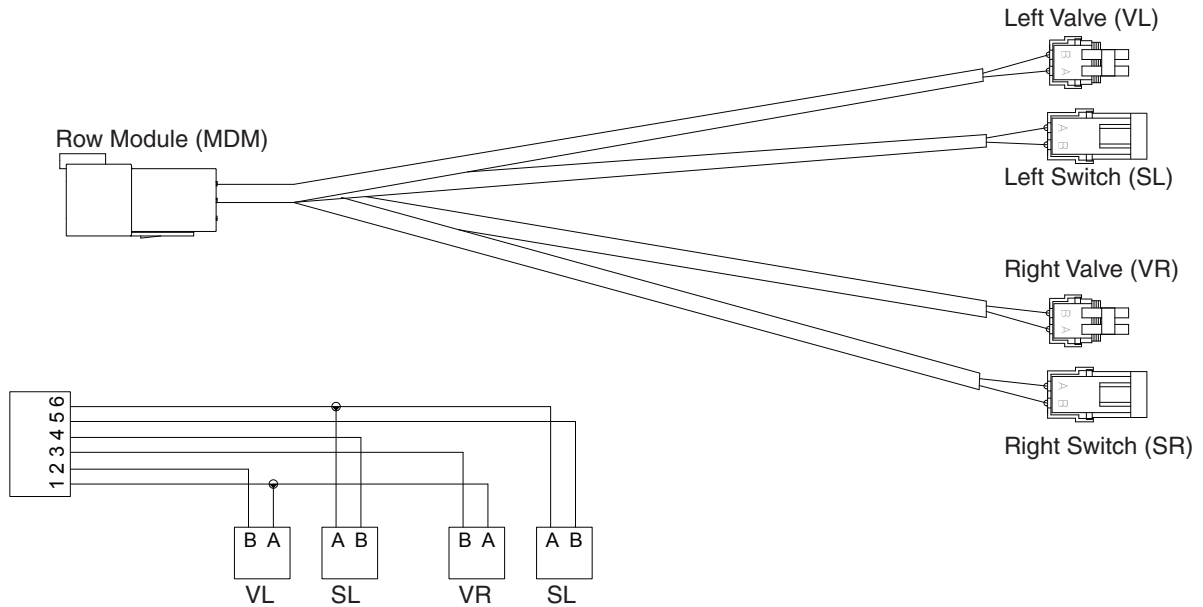

P/N A19400

Signal	Wire Gauge	Color	RM	VL	SL	VR	SR
Power	16	Red	1	A	-	A	-
Left Fertilizer Switch	16	Green	4	-	B	-	-
Right Fertilizer Switch	16	Blue	5	-	-	-	B
Left Fertilizer Valve	16	Light Blue	2	B	-	-	-
Right Fertilizer Valve	16	Violet	3	-	-	B	-
Ground	16	Black	6	-	A	-	A

TEMPERATURE SENSOR CABLE

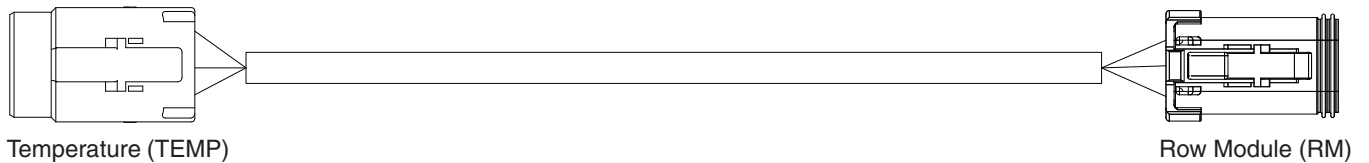

P/N A19419

Signal	Wire Gauge	Color	TEMP	RM
12VDC Sen Supply	18	Brown	1	5
Ground	18	Blue	2	2
Signal	18	Yellow/Green	3	6

HYDRAULIC HOSE LIFE

**WARNING**

Pressurized hydraulic fluid can penetrate body tissue and result in death, serious infection, or other injuries. Fluid injected under skin must be IMMEDIATELY removed by a surgeon familiar with this type of injury. Make sure connections are tight and hoses and fittings are not damaged before applying system pressure. Leaks can be invisible. Keep away from suspected leaks. Relieve pressure before searching for leaks or performing any system maintenance.



Proper storage of hydraulic hoses can significantly increase the life of the hoses, for a period of three to five years. After this period, service life of hoses may decrease, depending on variables such as variances in rubber materials and storage environment. Refer to the guidelines below for best practices when storing.

- Store in a clean, cool and dry area
- Avoid direct sunlight or moisture
- Do not store near high power electrical equipment
- Avoid contact with corrosive chemicals
- Avoid ultraviolet light
- Avoid areas with obvious signs of insects or rodents

Unusually long periods of storage or poor storage environment may lead to performance issues or premature failure. Always inspect all hoses prior to use for extensive wear, cuts, or holes. If such flaws are identified, replace immediately to avoid potential failure, property damage or bodily injury.

This page intentionally left blank.

HYDRAULIC SCHEMATIC (PLANTER RAISING)

24 Row Shown

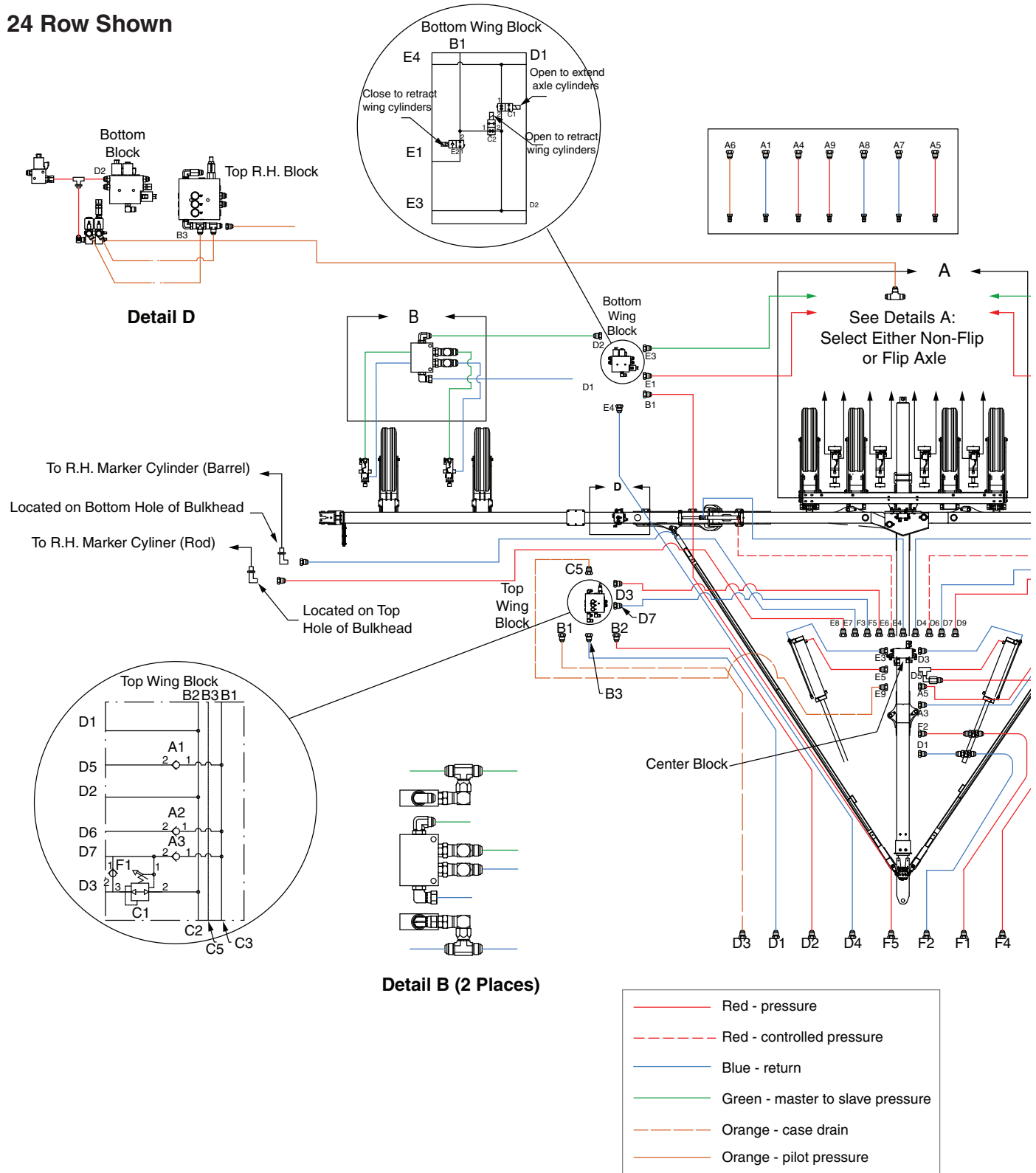

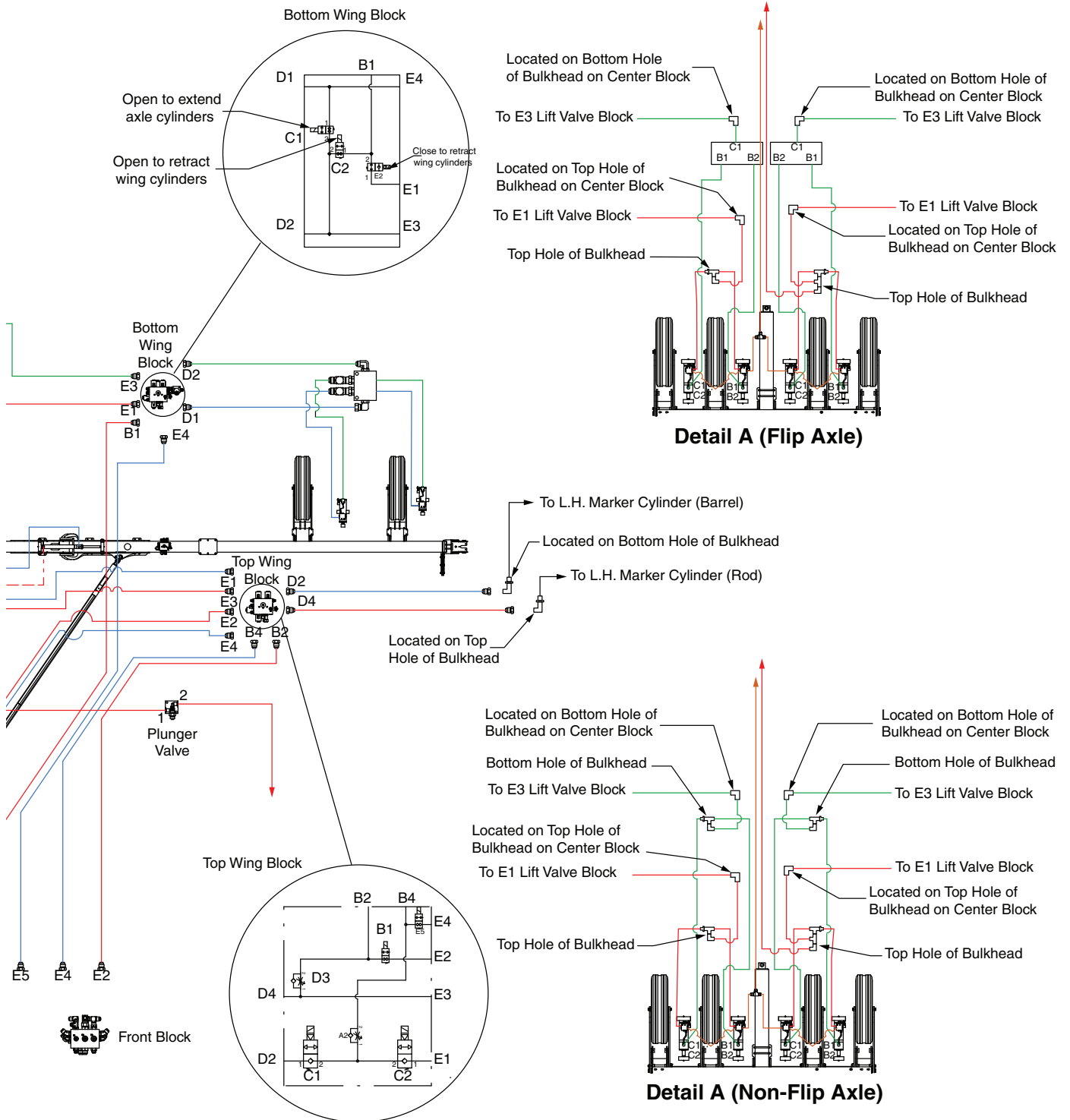

HYDRAULIC SCHEMATIC (OPTIONS)

(For Hydraulic Drive Option, see ["Hydraulic Schematic \(Hydraulic Drive Option\)"](#) on page 6-68)

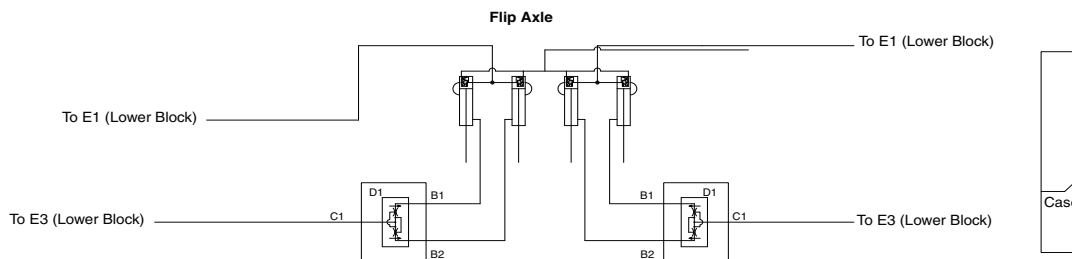
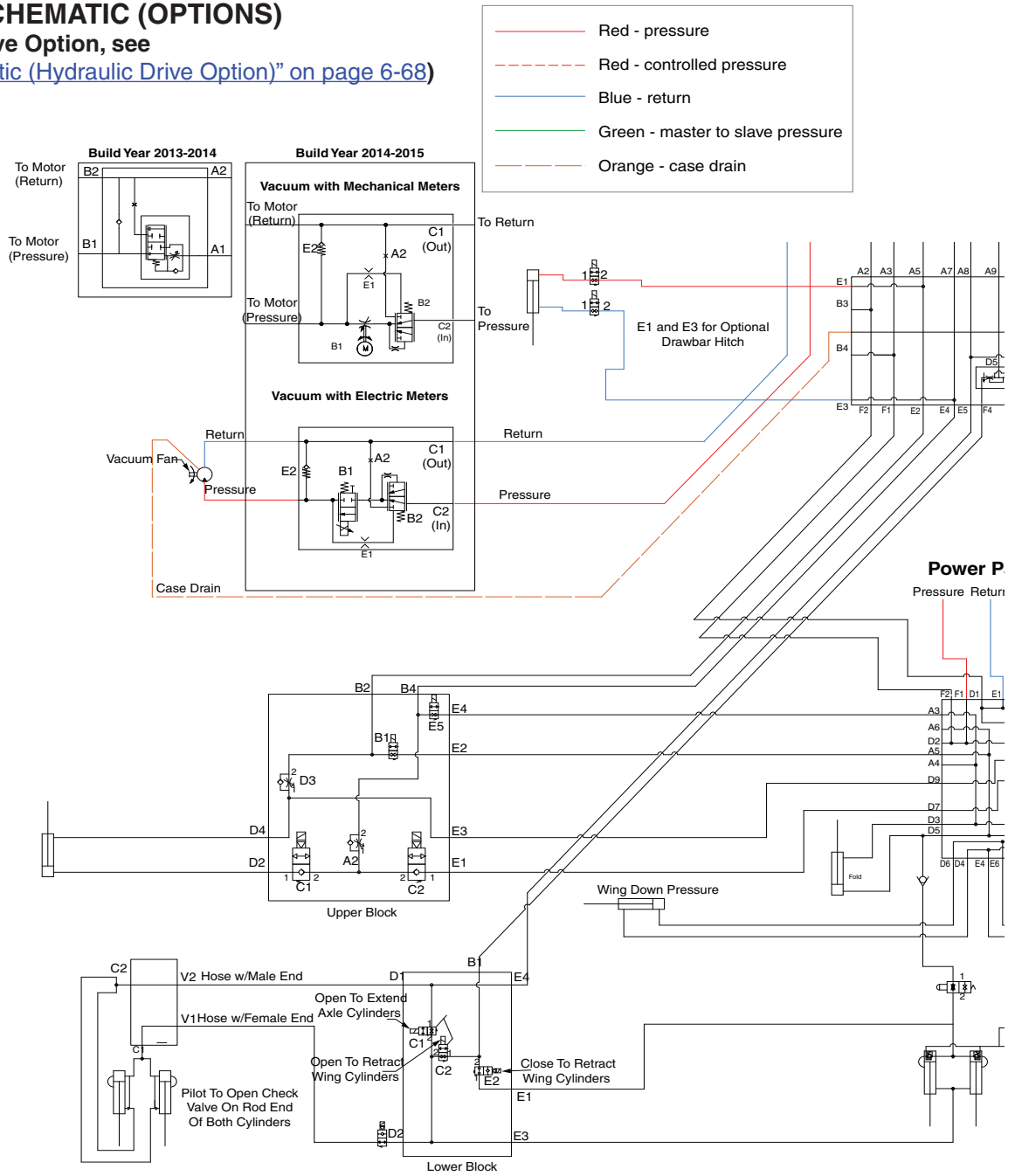

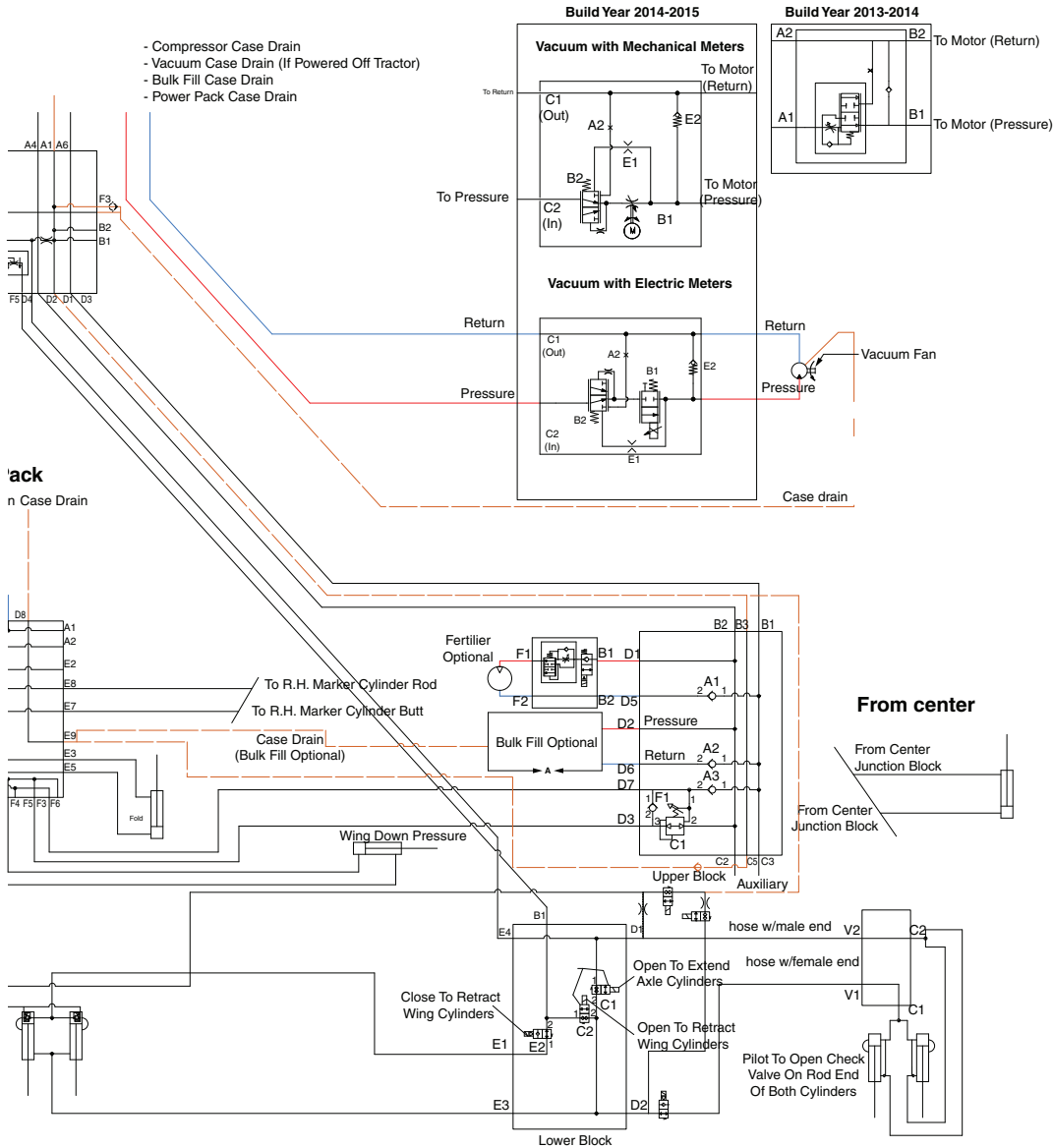

- Compressor Case Drain
- Vacuum Case Drain (If Powered Off Tractor)
- Bulk Fill Case Drain
- Power Pack Case Drain

ack
n Case Drain

D8
A1
A2
E2
E8
E7
E9
E3
E5
F4
F5
F3
F6
Fold

Fertilizer Optional
Bulk Fill Optional
Case Drain (Bulk Fill Optional)
Wing Down Pressure

From center
From Center Junction Block

Build Year 2014-2015
Bulk Fill with Electric Meters

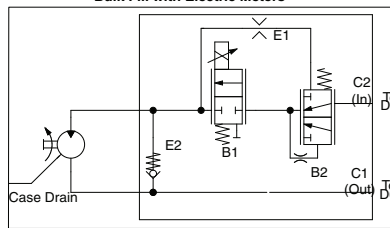

Build Year 2013-2014
Bulk Fill Option

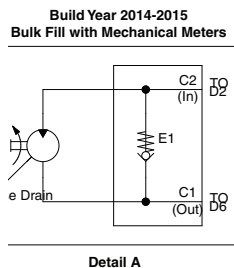
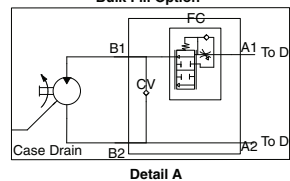

Detail A

Detail A

HYDRAULIC SCHEMATIC (HYDRAULIC DRIVE OPTION)

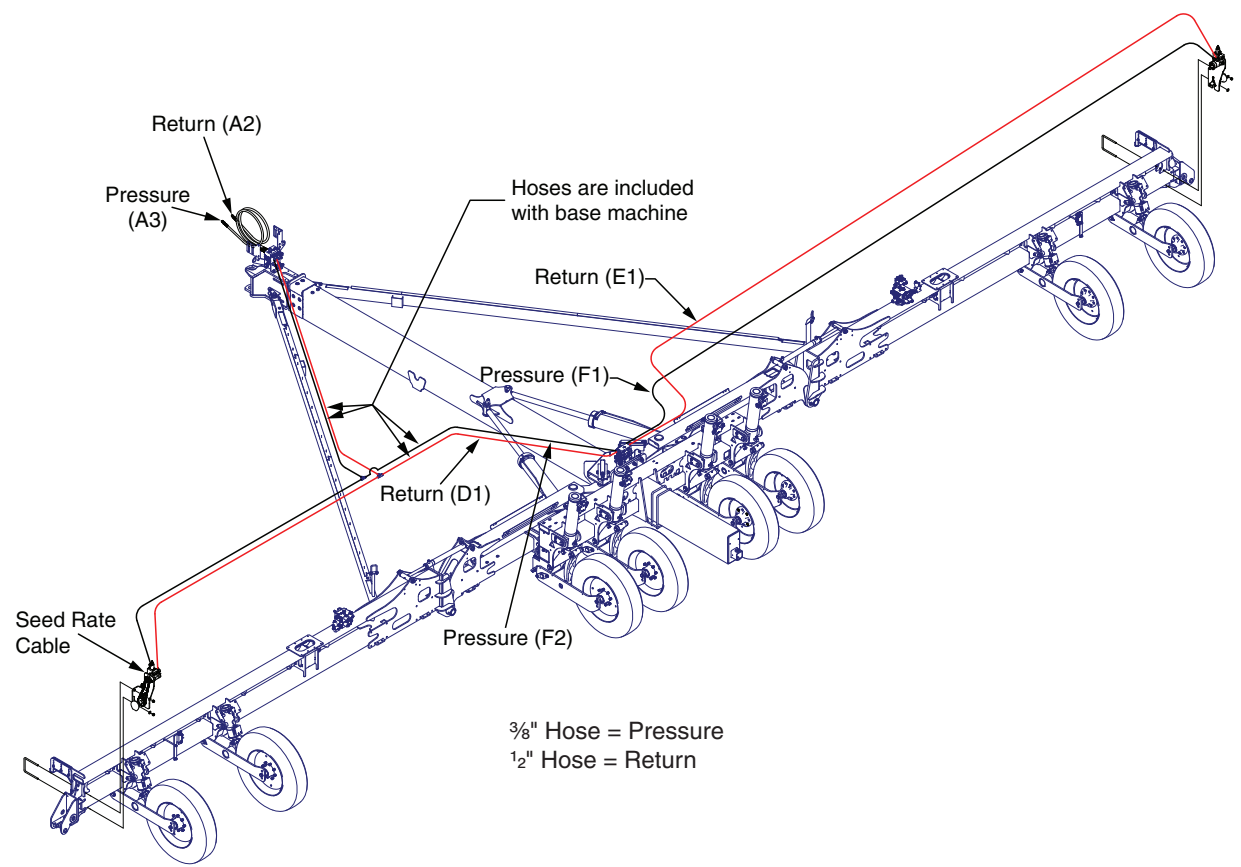

HYDRAULIC VALVE BLOCK FUNCTIONS

Valve Assembly	Name	Function
A17851	Front Hitch Block	Connects the hoses from the tractor to the planter hosing. Houses flow divider valve for lift circuit.
A17855	Marker/Fold Block	Located on top of the lift circuit block on the left wing. Contains control valves and flow control valves for left and right markers. Contains control valves for the fold circuit.
A17853	Lift Circuit Block	Bottom block on left and right wings. Contains control valves that allow the center axle to be raised to transport position and wing wheels to be raised for transport.
A17852	Rear Junction Block	Connection point for all center rear hoses.
A17854	Options and Wing Down Pressure	Located on the right wing, on top of the right wing lift circuit block. Contains the pressure reducing valve for wing down pressure and serves as a junction point for ASD, liquid fertilizer pump circuits and auxiliary functions.

This page intentionally left blank.

BULK FILL

PROBLEM	POSSIBLE CAUSE	SOLUTION
Seed does not travel through delivery tubes.	System pressure set too low.	Increase system pressure.
Seed stops flowing to row unit during planting.	Seed surging.	Shut down air seed delivery system and restart system from idle; seed should start flowing.
	Debris in system.	Insert shutoff door, open cleanout door. remove plug.
Seed does not move from entrainer at startup after exposure to water.	Seed swelled in entrainer.	Insert shutoff door, open cleanout door. remove swelled seed.
Seed bridging in entrainer.	System pressure too high.	Decrease system pressure to recommended pressures: <ul style="list-style-type: none"> • Corn - 12" (30 cm) of water • Soybean - 10" (25 cm) of water <p>NOTE: Actual pressure needed is affected by seed size, shape and coating.</p>

CLOSING WHEEL

PROBLEM	POSSIBLE CAUSE	SOLUTION
Closing wheel(s) leave severe imprint in soil.	Too much closing wheel down pressure.	Adjust closing wheel pressure.
Closing wheel(s) not firming soil around seed.	Not enough closing wheel down pressure.	Adjust closing wheel pressure. Severe no till conditions may require use of cast iron closing wheels.
"V" closing wheel running on top of seed furrow.	Improper centering.	Align. See "V" Closing Wheel Adjustment (Rubber or Cast Iron)" on page 3-1.
Single closing wheel not directly over seed.	Improper centering.	Align. See "Covering Discs/Single Press Wheel Adjustment" on page 3-2.

PISTON PUMP

PROBLEM	POSSIBLE CAUSE	SOLUTION
Pump hard or impossible to prime.	Valves fouled or in wrong place.	Inspect and clean valves.
	Air leak in suction line.	Repair leak.
	Pump set too low.	Adjust pump setting.
	Packing washers worn out.	Replace.
Low metering.	Valves fouled or in wrong place.	Inspect and clean valves.
	Air leak in suction line.	Repair leak.
	Pump set too low.	Adjust pump setting.
	Broken valve spring.	Replace spring.
Over meters.	Broken discharge valve spring.	Replace spring.
	Trash under valves.	Inspect and clean valves.
	Improper rate setting.	Adjust pump setting.
Leaks through when stopped.	Broken discharge valve spring.	Replace spring.
	Trash under valves.	Inspect and clean valves.
Fertilizer solution leaking under stuffing box.	Packing washers worn out.	Replace.
Pump using excessive oil.	Oil seals or O-ring worn and leaking.	Replace.
Pump operates noisily.	Crankcase components worn excessively.	Inspect and replace if necessary.

CENTRIFUGAL PUMP

PROBLEM	POSSIBLE CAUSE	SOLUTION
Centrifugal pump does not turn on.	Bulk fill remote turned off.	Turn bulk fill remote (identified by yellow hoses) on.
	Master Switch turned off.	Turn Master Switch on.
	Fertilizer turned off.	Turn fertilizer on.
	Tank is empty.	Ensure fluid is in the tank.
Fertilizer fluctuates going across the field.	Low flow.	Ensure bulk fill remote (identified by yellow hoses) is at maximum flow.
	Low fluid level.	Add fluid to tank.
	Incorrect orifice size for rate and speed.	Refer to orifice chart in the Rate Chart section of this manual and select the correct orifice for your application.
	Gain value set too high.	Lower the Gain value in the Fertilizer settings menu by .01.

GFX HYDRAULIC ROW CLEANERS

PROBLEM	POSSIBLE CAUSE	SOLUTION
During operation, the engagement of hydraulic circuit causes the pressure immediate rise to system relief (2500 psi) and at same time the electronic control is unresponsive.	Main SCV return line is not fully connected.	Connect main SCV return line.
Control system is operating properly in every way but does not generate enough pressure.	Flow rate is too high. Hydraulic horsepower is a function of flow and pressure. If system is running at a very high flow for a given amount of horsepower it will reduce maximum pressure.	Reduce the flow to 10-20% of the system maximum or more typically 2-3 gpm.

ROW MARKER OPERATION

PROBLEM	POSSIBLE CAUSE	SOLUTION
Right marker lowering slower than left marker.	Solenoid valve cartridge in port V1 not opening completely.	Switch with cartridge in port V2. If problem repeats, replace cartridge.
	Hose pinched or collapsed.	Inspect hose routing. Replace or repair hoses as required.
Left marker lowering slower than right marker.	Solenoid valve cartridge in port V2 not opening completely.	Switch with cartridge in port V1. If problem repeats, replace cartridge.
	Hose pinched or collapsed.	Inspect hose routing. Replace or repair hoses as required.
Both markers lowering.	Solenoid valve cartridge stuck open. If left marker switch is selected, right cartridge (V1) is defective. If right marker switch is selected, left cartridge (V2) is defective.	Replace solenoid valve cartridge.
Neither marker lowers.	Blown fuse.	Check red light on control console. It should be on if switch is on. If light is not on, switch to opposite marker position. If light comes on, switch may be defective. Replace switch. Otherwise replace fuse.
	Coils at V1 and V2 not energized.	Poor ground on wire, bad wire connection or damaged wire. Repair as required.
	Marker flow control valve closed too far.	See "Row Marker Speed Adjustment" on page 2-57.
Neither marker will raise.	Marker flow control valve closed too far.	See "Row Marker Speed Adjustment" on page 2-57.
Right marker will not lower.	Solenoid coil in port V1 not energized.	Check switch on control console. Replace if defective. Check coil ground wire. Check for poor connection or damaged wire.
	Solenoid cartridge in port V1 stuck closed.	Switch cartridge with one on the planter you know is operating properly. If right marker lowers, replace defective cartridge.
Left marker will not lower.	Solenoid coil in port V2 not energized.	Check switch on control console. Replace if defective. Check coil ground wire. Check for poor connection or damaged wire.
	Solenoid cartridge in port V2 stuck closed.	Switch cartridge with one on the planter you know is operating properly. If left marker lowers, replace defective cartridge.
Markers traveling too fast and damaging rubber stop on transport stands and/or damaging pivot at rod end of marker cylinders.	Adjust row marker flow control valve.	See "Row Marker Speed Adjustment" on page 2-57.

VACUUM SEED METER

PROBLEM	POSSIBLE CAUSE	SOLUTION
Low seed count.	Meter RPM too high.	Reduce planting rate or planting speed.
	Singulator blade setting too aggressive.	Adjust singulator blade.
	Vacuum level too low.	Increase fan speed.
	Seed sensor not picking up all seeds dropped.	Clean seed tube. Move meter to different row.
	Seeds sticking to seed disc.	Use graphite or talc to aid release.
	Seed treatment buildup in seed disc recesses.	Reduce amount of treatment used and or mix thoroughly. Add talc.
	Seed size too large for disc used.	Use appropriate disc for seed size.
	Wrong seed disc.	Use appropriate disc for seed type and size.
	Failed/worn drive components.	Inspect and replace parts as required.
	Plugged orifices in seed disc.	Inspect and clean disc. Check remnant ejector.
	Loss of vacuum at meter.	Check for foreign material between vacuum cover and disc. Inspect parts for wear/damage. Clean or replace as required.
	Seed bridging in hopper.	Add graphite to improve seed flow.
	Faulty vacuum gauge reading.	Repair/replace gauge.
	Dirt in vacuum manifold.	Check vacuum manifold for dirt and clean.
	Seed baffle (If applicable) not allowing seed flow due to bridging of seed.	Mix talc thoroughly to coat all seeds. Remove seed baffle. See Row Unit Operation section.
	Seed disc worn.	Replace.
Vacuum seal worn.	Replace.	
Not planting seed.	Seed hoppers empty.	Fill seed hopper.
	Seed tube plugged/damaged.	Clean or replace tube.
	Meter drive damaged.	Repair/replace drive components.
	Low/no vacuum.	Inspect vacuum system and repair as necessary.
	Singulator blade setting too aggressive.	Adjust singulator blade.
	Faulty vacuum gauge.	Repair/replace vacuum gauge.
	Seed bridging in hopper.	Add graphite to improve seed flow.
	Loss of vacuum at meter.	Check for foreign material between vacuum cover and disc. Inspect parts for wear/ damage. Clean and/or replace as required.
	Wrong seed disc.	Use appropriate disc for seed type and size.
	Meter drive clutch not engaged.	Engage drive clutch.
	Fan not running.	Start fan.
	Dirt in vacuum manifold.	Check vacuum manifold for dirt and clean.

Continued on next page.

VACUUM SEED METER - Continued

PROBLEM	POSSIBLE CAUSE	SOLUTION
Not planting seed. (Continued)	Seed baffle (if applicable) not allowing seed flow due to bridging of seed.	Mix talc thoroughly to coat all seeds. Remove seed baffle. Row Unit Operation section.
	High vacuum.	Adjust vacuum level to appropriate level.
	Wrong seed disc.	Replace seed disc.
	Singulator setting not aggressive enough.	Adjust singulator.
	Faulty vacuum gauge.	Check gauge line for dirt/obstruction. Repair/replace vacuum gauge.
Poor seed spacing.	Obstruction in seed tube.	Clean seed tube.
	Dirty/damaged seed disc.	Inspect seed disc for damage, foreign material in orifices or seed treatment buildup in recesses. Clean or replace.
	Wrong vacuum setting.	Adjust vacuum to appropriate level.
	Excess foreign material in seed.	Inspect and clean meter and seed discs. Use clean, undamaged seed.
	Incorrect singulator setting.	Adjust singulator to appropriate setting.
	Inconsistent driveline.	Inspect drive components for rust, misalignment, worn or damaged parts. Replace/repair as required.
	Toolbar not level or wrong height.	Adjust hitch to level toolbar and row units.
	Planting too fast for conditions.	Reduce speed.
	Rough field conditions.	Reduce speed.
Irregular seed population.	Driving too fast.	Reduce speed.
Unable to achieve desired vacuum level.	Tractor hydraulic flow set too low.	Increase flow to fan motor.
	Incorrect hydraulic connections.	Check all hydraulic connections and hose routings.
	Damaged fan components.	Inspect motor and impeller for wear/damage and repair/replace as necessary.
	Vacuum hose pinched/kinked/blocked.	Inspect air lines for any damage or obstruction. Clean air lines and manifold by removing end cap from manifold and running fan at high speed.
	Vacuum hose loose/disconnected.	Inspect and reattach all air hoses.
	Tractor not producing required hydraulic flow/pressure.	Have tractor serviced by qualified technician.
	Dirt in vacuum gauge line.	Check gauge line for dirt/obstruction and clean.

SOLENOID VALVE

PROBLEM	POSSIBLE CAUSE	SOLUTION
No solenoids operate.	Low voltage.	Must be connected to 12 volt DC only. Negative ground.
	Blown fuse.	Replace control console fuse with AGC-15 amp.
	Battery connection.	Clean and tighten.
	Wiring harness damaged.	Repair or replace.
One solenoid valve will not operate.	Bad switch.	Replace on control panel.
	Cut wire in harness.	Locate and repair.
	Bad coil.	Replace.
	Poor connection at coil.	Check.
Valve operating when not energized.	Valve stem stuck open.	Replace cartridge.
	O-ring leaking.	Install new O-ring kit.
	Foreign material under poppet.	Remove and clean cartridge.

PTO PUMP DRIVE AND OIL COOLER OPTION

PROBLEM	POSSIBLE CAUSE	SOLUTION
Pump is squealing.	Lack of oil to pump.	Check for plugged suction strainer. Check oil level.
Oil temperature high.	Low oil level.	Check oil level and add as required.
Desired fan speed cannot be achieved.	Low oil level.	Check oil level and add as required.
	Plugged filter.	Check and change as required.