

M0297 Rev. 3/21

QUICK-START GUIDE*

for MACH TILL 412

* Refer to operators manual for complete safety and operation info.

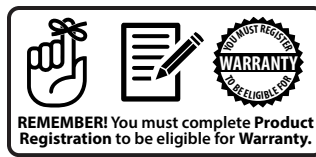

KINZE

A Connect Hydraulics

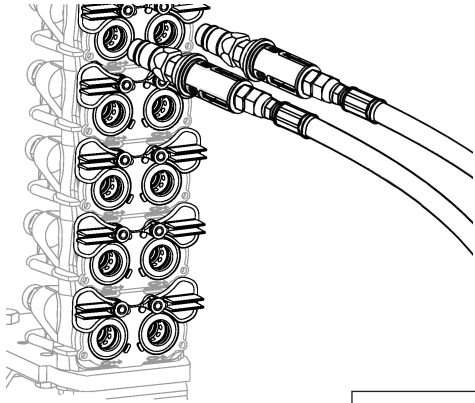

- 1 WHEELS
- 2 ROLLERS
- 3 TRANSPORT
- 4 WINGS
- 5 JACK

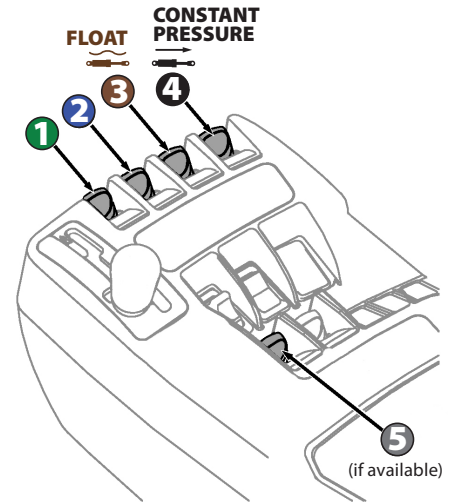

IMPORTANT: The *Wing Cylinder Circuit* includes a *Down Pressure Valve*. Operator must engage wing circuit hydraulics **constantly** in the extended direction to ensure constant down pressure.

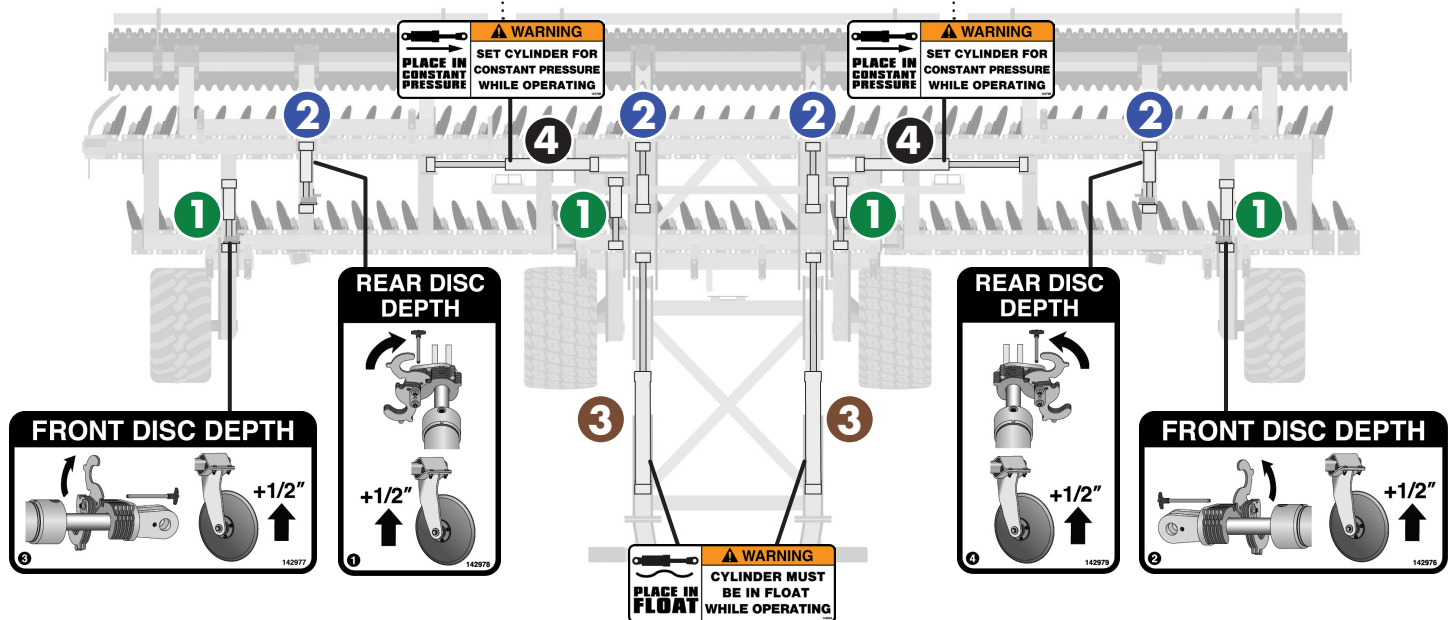

Maintenance

(Check Machine Daily)

- Hydraulic Connections/Hoses
- Working points & pins
- Hubs, Spindles, & Tire Pressure:
 - Center: **58 PSI (400 kPa)**
 - End Wheels: **58 PSI (400 kPa)**
- Check for missing, worn or damaged parts.

* Refer to operators manual for complete safety and operation info.



GPS Reference

(Set overlap to 6" per side)

(with 20" discs)	2" Depth
Mach Till 41	491" (12.47m)
Mach Till 45	532" (13.51m)
(with 20" discs)	MAX Depth
Mach Till 41	493" (12.52m)
Mach Till 45	534" (13.56m)

(Consider setting the GPS to include a 6" implement offset to the right)

* Refer to operators manual for complete safety and operation info.

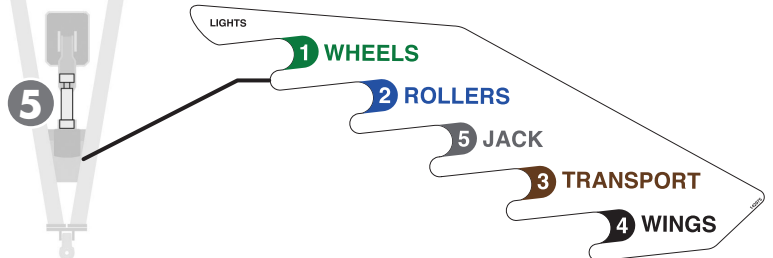

B Put in Field Position

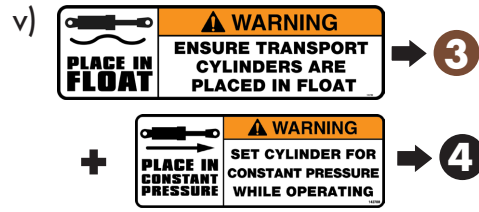
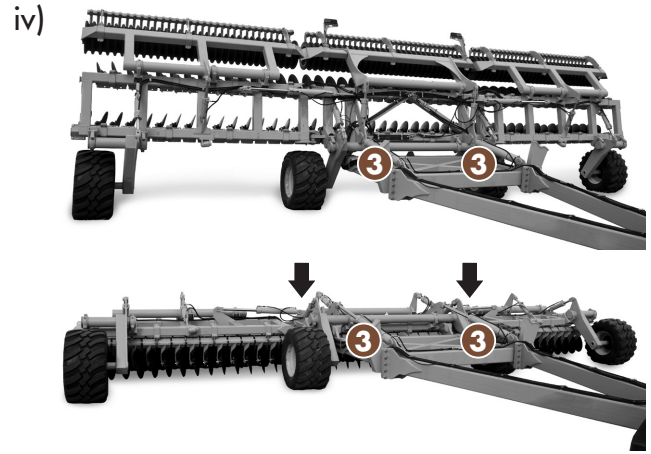
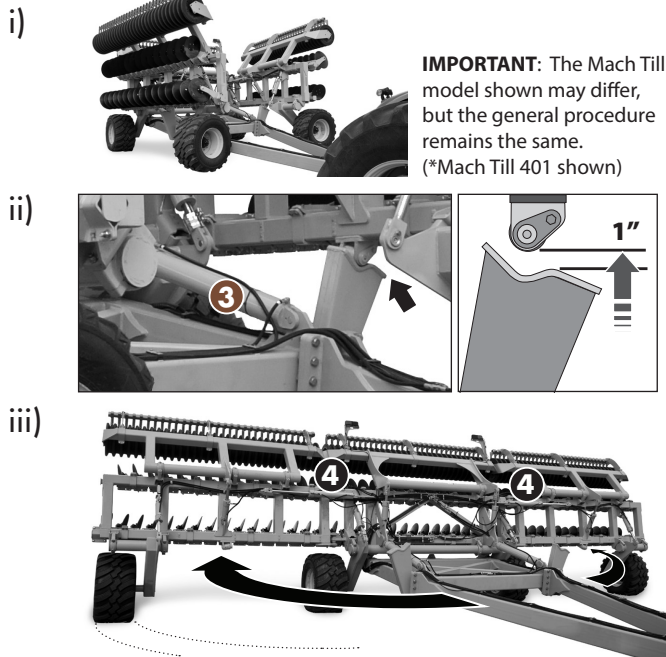

IMPORTANT: Operator must read and understand the tractor manual in order to place the required hydraulic circuits into **float position** or **constant pressure position**.

C Set Cutting Depth

IMPORTANT: Re-phase and cycle oil in the Depth Control Cylinders ① ② before use. This is especially important after long periods of storage.

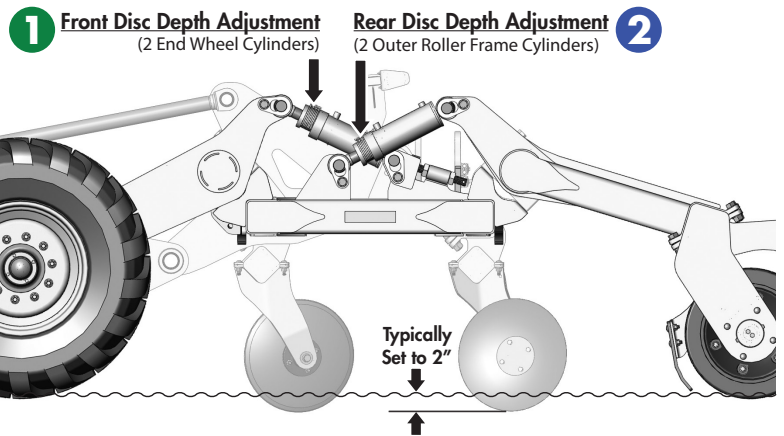
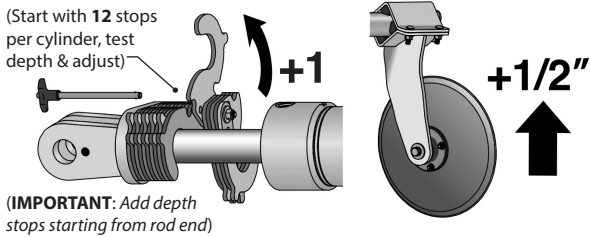

D Test. Check. Adjust.

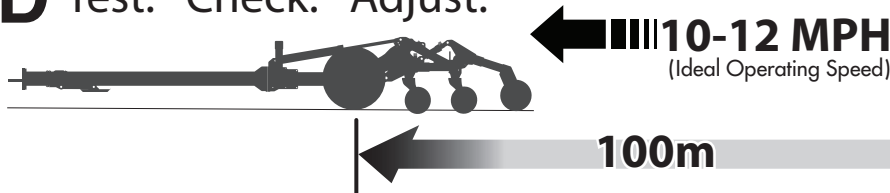

E Lower ① Wheels for Headland Turns.

F MAX Transport Speed: 40 km/h (25 MPH)

Scraper Position Overview (Rubber Rollers)

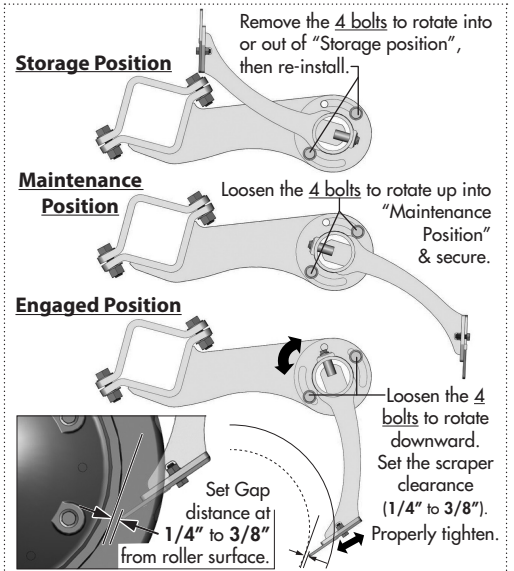

*** Reference Sheet Quick-Start Guide**

OPERATORS SECTION - TABLE OF CONTENTS

IMPORTANT Safety Notice

Introduction	1
Safety	2
Hook-Up	4
Transport	5
Transport to Field Position	6
Field to Transport Position	7
Operation	8
Pre-Operation Checklist	8
Operation Guidelines / Suggestions	9
Setting Disc Depth	10
Scraper Settings	12
Troubleshooting	13
Service & Maintenance	15
Maintenance Checklist	15
Repair - Wheel Hub	18
Repair - Hyd Cylinder Repair	19
Repair - Pressed Bushing	20

PARTS SECTION - TABLE OF CONTENTS

Mach Till Section Overview	23
Hitch Pole Frame Components	24
Wheel & Rockshaft Components	26
Center Frame Components	27
End Wheel Components	29
Wing Frame Components	29
Disc Gang Assembly & Components	30
Disc Arm Components & Disc Options	32
Roller Frame Components	33
Roller & Scraper Components	36
Hydraulic Routing & Cylinders	38
Light Routing	44
Warranty	45

Maintenance Free Pins & Bushings

 **IMPORTANT: INSTALL DRY** 

Do NOT use any oil/grease/lubricant on pin or bushing surfaces when installing the maintenance free pins into composite bushings.

⚠ **DANGER - NEVER PARK, UNHOOK, or SERVICE** Mach Till with **REAR WINGS RAISED**

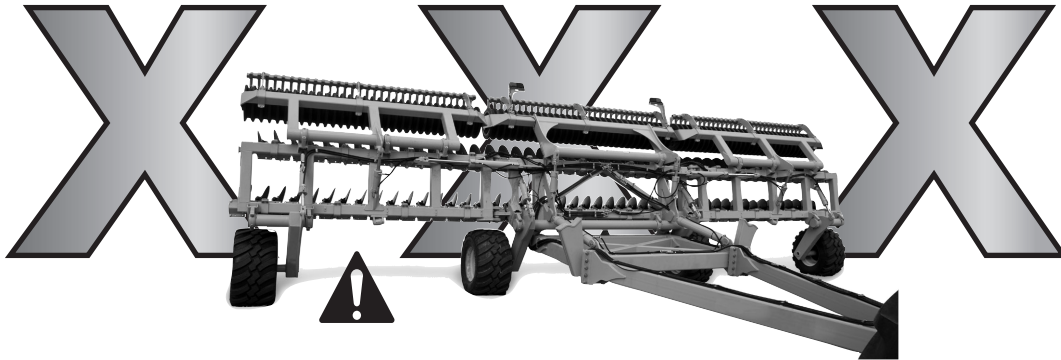

⚠ DANGER
NEGATIVE TONGUE WEIGHT ON HITCH
Can cause serious injury or death.

- Make certain that implement is securely hitched to the tractor at all times.
- Do not unhook implement from tractor unless it is in the proper field or transport position.

142963

⚠ **DANGER**

If the front hitch becomes disconnected in this position the front hitch will raise suddenly and the back of the machine will drop!

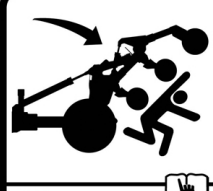
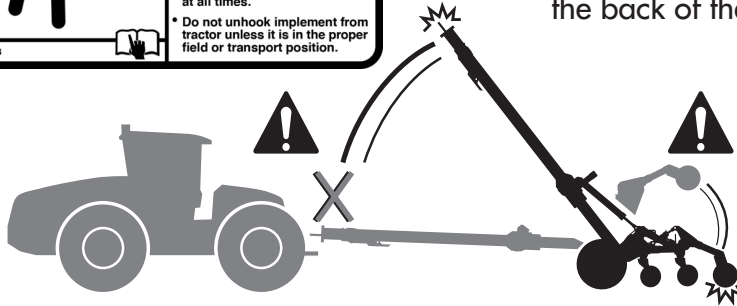

⚠ DANGER
CRUSHING HAZARD
Can cause serious injury or death.

- Stay clear of this area.

142965

CHANGING DISCS AND SERVICING

The best position to safely change or service the discs on the Mach Till is when it is secured in the winged forward transport position.

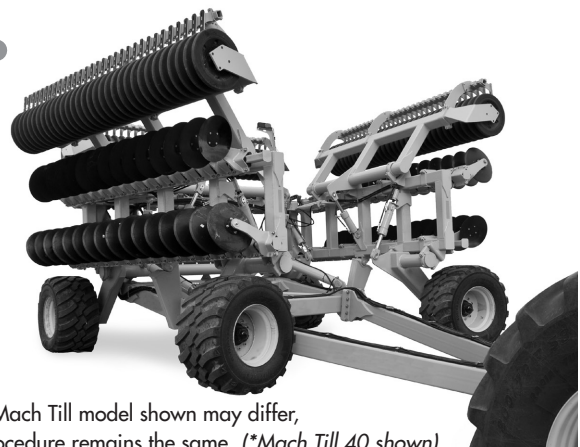

IMPORTANT: The Mach Till model shown may differ, but the general procedure remains the same. (*Mach Till 40 shown)

Introduction



CONGRATULATIONS on your choice of a Kinze Mach Till to complement your farming operation. It has been designed and manufactured to meet the needs of a discerning agricultural market. Kinze Mach Till shreds heavy fall residue, opens up spring fields, levels ruts, destroys clods and produces an absolutely perfect seed bed. Kinze Mach Till is the fastest and most versatile piece of tillage equipment you will ever own. Use this manual as your first source of information about this machine.

TO THE NEW OPERATOR OR OWNER - Safe, efficient and trouble free operation of your Kinze Mach Till requires that you and anyone else who will be operating or maintaining it, read and understand the Safety, Operation, Maintenance and Troubleshooting information contained within this manual.

By following the operating instructions in conjunction with a good maintenance program your machine will provide many years of trouble-free service. Keep this manual handy for frequent reference and to pass on to new operators or owners. Call your Kinze Dealer if you need assistance, information, or additional copies of the manual.

OPERATOR ORIENTATION - The directions left, right, front and rear, as mentioned throughout the manual, are as seen from the tractor drivers' seat and facing in the direction of travel.

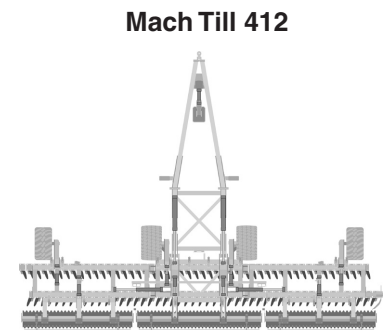
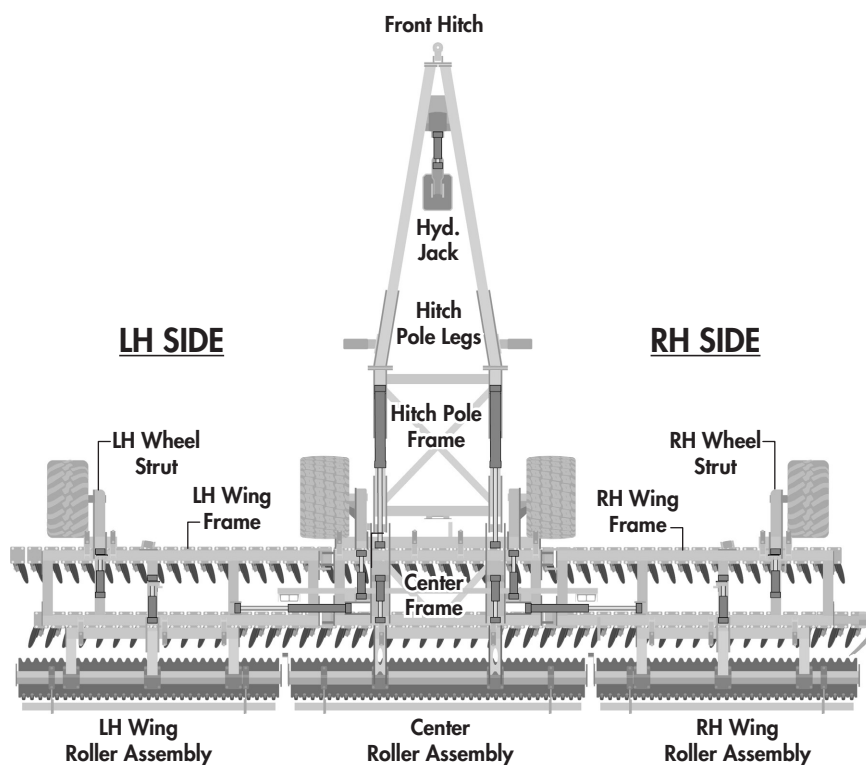

Why is **SAFETY** important to **YOU**?

3 **BIG** Reasons:

- **Accidents Can Disable and Kill**
- **Accidents Are Costly**
- **Accidents Can Be Avoided**



SAFETY ALERT SYMBOL

The **Safety Alert Symbol** identifies important safety messages applied to the Mach Till and in this manual. When you see this symbol, be alert to the possibility of **injury or death**. Follow the instructions provided on the safety messages.

The **Safety Alert Symbol** means:

ATTENTION!
BECOME ALERT!
YOUR SAFETY IS INVOLVED!

SIGNAL WORDS

Note the use of the Signal Words: **DANGER**, **WARNING**, and **CAUTION** with the safety messages. The appropriate Signal Word has been selected using the following guidelines:



DANGER: Indicates an imminently hazardous situation that, if not avoided, **WILL** result in death or serious injury if proper precautions are not taken.



WARNING: Indicates a potentially hazardous situation that, if not avoided, **COULD** result in death or serious injury if proper precautions are not taken.



CAUTION: Indicates a potentially hazardous situation that, if not avoided, **MAY** result in minor or moderate injury if proper practices are not taken, or, serves as a reminder to follow appropriate safety practices.

Safety

SAFETY

YOU are responsible for the safe operation and maintenance of your Kinze Mach Till.

YOU must ensure that you and anyone else who is going to operate, maintain or work around the Mach Till be familiar with the operating and maintenance procedures and related **SAFETY** information contained in this manual.

This manual will take you step-by-step through your working day and alerts you to all good safety practices that should be adhered to while operating this equipment.

Remember, **YOU** are the key to safety. Good safety practices not only protect you but also the people around you. Make these practices a working part of your safety program. Be certain that **EVERYONE** operating this equipment is familiar with the recommended operating and maintenance procedures and follows all the safety precautions. Most accidents can be prevented. Do not risk injury or death by ignoring good safety practices.

- Mach Till owners must give operating instructions to operators or employees before allowing them to operate the Mach Till, and at least annually thereafter per OSHA regulation 1928.51.
- The most important safety device on this equipment is a SAFE operator. It is the operator's responsibility to read and understand ALL Safety and Operating instructions in the manual and to follow these. All accidents can be avoided.
- A person who has not read and understood all operating and safety instructions is not qualified to operate the machine. An untrained operator exposes himself and bystanders to possible serious injury or death.
- Do not modify the equipment in any way. Unauthorized modification may impair the function and/or safety and could affect the life of the equipment.
- Think SAFETY! Work SAFELY!

GENERAL SAFETY

1. Read and understand the Operator's Manual and all safety signs before operating, maintaining or adjusting.



2. Install and properly secure all shields and guards before operating. Use hitch pin with a mechanical locking device.

3. Have a first-aid kit available for use should the need arise and know how to use it.



4. Have a fire extinguisher available for use should the need arise and know how to use it.



5. Wear appropriate protective gear. This list includes but is not limited to:

- A hard hat
- Protective shoes with slip resistant soles
- Protective glasses or goggles
- Heavy gloves
- Wet weather gear
- Hearing protection
- Respirator or filter mask

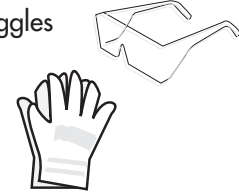

6. Clear the area of people, especially small children, and remove foreign objects from the machine before starting and operating.
7. Do not allow riders.
8. Stop tractor engine, set park brake, remove ignition key and wait for all moving parts to stop before servicing, adjusting, repairing or unplugging.
9. Review safety related items with all operators annually.

Hook-Up

HOOK-UP / UNHOOKING

The Mach Till should always be parked on a level, dry area that is free of debris and foreign objects. Follow this procedure to hook-up:

1. Clear the area of bystanders and remove foreign objects from the machine and working area.
2. Make sure there is enough room to back the tractor up to the trailer hitch.
3. Start the tractor and slowly back it up to the hitch point.
4. Connect the hydraulics. To connect, proceed as follows:
 - Use a clean cloth or paper towel to clean the couplers on the ends of the hoses. Also clean the area around the couplers on the tractor. Remove the plastic plugs from the couplers and insert the male ends.
 - Be sure to match the pressure and return line to one valve bank.
 - Hoses have been labelled in a suggested order of priority from most used to least: (1) Wheels (2) Rollers (3) Transport (4) Wings (5) Jack
5. Use the hydraulic jack controls to raise or lower the hitch to align with the drawbar.

▲ IMPORTANT: Close the ball valve (if equipped) to prevent accidental operation of this circuit. Ensure ball valve handle remains in closed position.

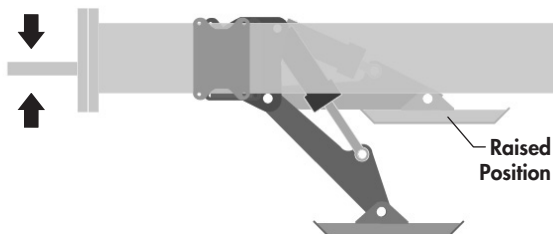

▲ WARNING: Tractor **MUST** be equipped with a clevis hitch to prevent unit from tipping upward while folding into and out of transport. A safety chain must also always be properly installed.

6. Slowly back tractor up to align the hitch.
7. Install a drawbar pin with provisions for a mechanical retainer such as a KLIK pin. Install the retainer.
8. Install a safety chain between the tractor and the hitch.
9. Connect lights (electrical socket plug) to tractor.
10. Raise the hydraulic hitch jack.
11. When unhooking from the tractor, reverse the above procedure.

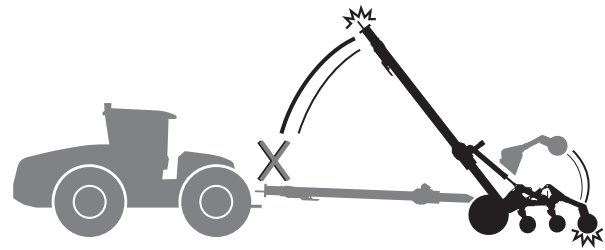

▲ WARNING/DANGER:

Never disconnect Mach Till from tractor if rear sections of machine are partially raised.

Negative Hitch Weight may result, the hitch pole may suddenly raise, and the rear section would come crashing down. Only disconnect when unit is on level ground in the proper transport or field position.

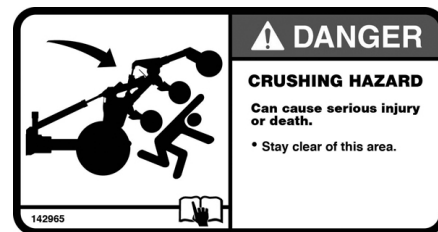

▲ WARNING/DANGER:

The tractor **MUST** be properly equipped with a clevis hitch and safety chain to prevent **Negative Hitch Weight** occurring when raising or lowering the rear sections.

If the unit is not properly attached to the tractor with a clevis hitch and safety chain, the negative hitch weight could result in the hitch pole suddenly raising and the rear section to come crashing down.

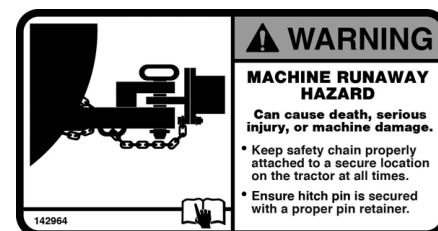

Transport

TRANSPORT SAFETY

1. Read and understand ALL the information in the Operator's Manual regarding procedures and SAFETY when operating the Mach Till in the field/yard or on the road.
2. Check with local authorities regarding machine transport on public roads. Obey all applicable laws and regulations.
3. Always travel at a safe speed. Use caution when making corners or meeting traffic.
4. Make sure the SMV (Slow Moving Vehicle) sign, and all the lights and reflectors that are required by the local highway and transport authorities are in place, are clean and can be seen clearly by all overtaking and oncoming traffic. Be sure to check with local highway authorities and comply with their lighting and transport requirements.
5. Keep to the right and yield the right-of-way to allow faster traffic to pass. Drive on the road shoulder, if permitted by law.
6. Always use hazard warning flashers on tractor when transporting unless prohibited by law.
7. Always use a pin with provisions for a mechanical retainer and a safety chain when attaching to a tractor or towing vehicle.

TRANSPORTING

Use the following guidelines while transporting the Mach Till:

1. Use a safety chain and a pin with provisions for a mechanical retainer.



2. Ensure Mach Till is in the full transport position with the wing rollers secure and properly in place.
3. Ensure debris that may fall or become dislodged during transport is removed.
4. Be sure hazard lights are flashing and SMV decal is visible.
5. **MAXIMUM RECOMMENDED TRANSPORT SPEED: MAX 40 km/h or 25 mph.** (Road Conditions, Field speeds may be lower.)
Due to weight of the machine and tire ratings, do not exceed the recommended maximum speeds or severe tire damage / excessive wear may occur.
6. If the Mach Till is to be towed in Transport for an extended duration with speeds up to 40km/hr, the centre frame wheels (transport tires) must be checked and properly inflated: **58 PSI (400 kPa).**

⚠ IMPORTANT: Under **NO CIRCUMSTANCES** should there ever be riders while the Mach Till is in transport.



Transport to Field Position Overview

TRANSPORT TO FIELD POSITION

FOLLOW PROCEDURE BELOW:

IMPORTANT: The Mach Till model shown may differ, but the general procedure remains the same.
(*Mach Till 40 shown)

A. On level ground, position the Mach Till so it is straight in-line behind the tractor.



B. **Slightly** extend the Transport Cylinders (#3) just enough to remove the weight of wings off from the wing transport carriers. Do not lift more than needed.

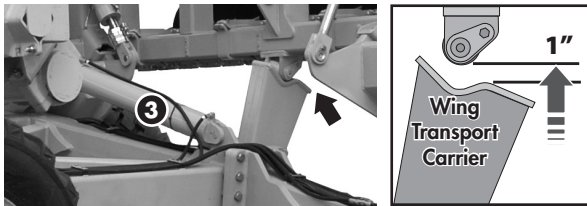

⚠ IMPORTANT: Do **Not** fully extend the transport cylinders at this point. Follow proper procedures to prevent possible equipment damage or failure.

C. Extend the Wing Cylinders (#4) to fully open the wings behind the machine.

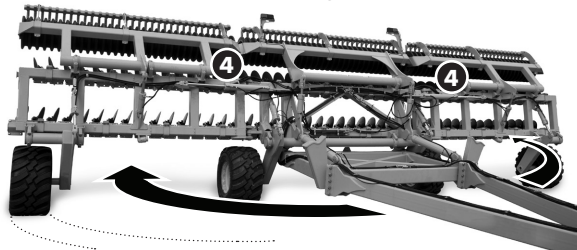

⚠ NEVER LIFT WINGS!

Unfold using the **Wing Cylinders (4)**, *then* lower all rear sections using the **Transport Cylinders (3)**.

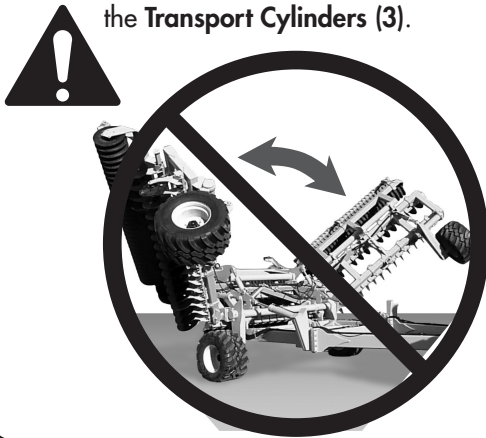

(IMPORTANT: The Mach Till model design may vary, but the general procedure remains the same. *Mach Till 40 shown.)

D. After fully opening the wings, extend the Transport Cylinders (#3) to completely lower all the Mach Till rear frame sections to the ground.

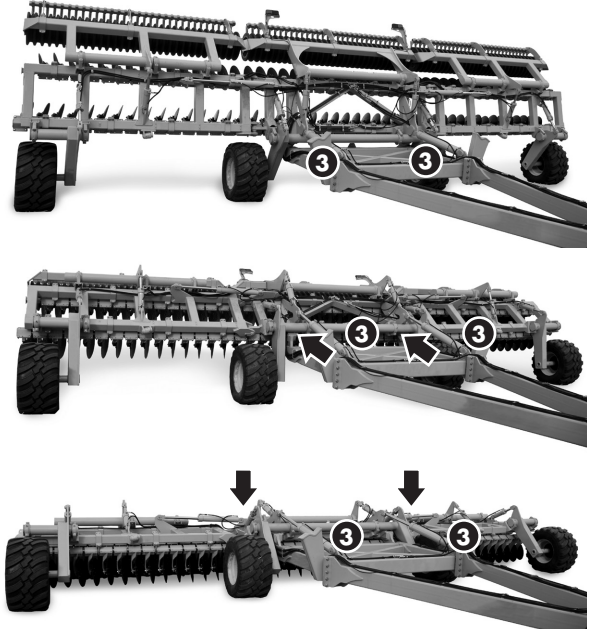

E. Place the Transport Cylinders (#3) into FLOAT position before operation.

⚠ IMPORTANT: The *Transport Cylinders* **MUST** be in the "FLOAT" position in order for the Mach Till to properly contour the ground and to avoid possible cylinder or equipment damage.



⚠ WARNING
ENSURE TRANSPORT CYLINDERS ARE PLACED IN FLOAT

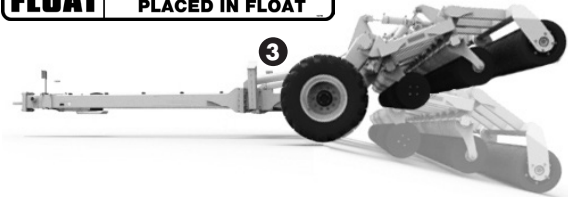

F. Wing Cylinders (#4):

During operation, the wing circuit hydraulics need to be engaged **constantly** from the tractor, in the extended direction. This will ensure constant down pressure is applied to the wings and the machine can still contour over uneven terrain effectively. (Refer to your tractor's manual for proper procedures.)

⚠ WARNING
SET CYLINDER FOR CONSTANT PRESSURE WHILE OPERATING

Field to Transport Position Overview

FIELD TO TRANSPORT POSITION

FOLLOW PROCEDURE BELOW:

IMPORTANT: The Mach Till model shown may differ, but the general procedure remains the same. (*Mach Till 40 shown)



A. Fully extend the Wheel & Roller Cylinders (#1 & #2) to completely raise the **disc frames**.

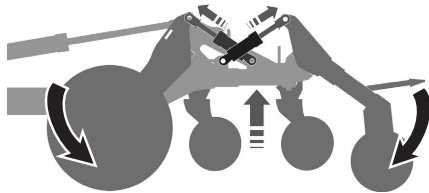

NOTE: It is important to fully raise the disc frames up as high as possible as it puts the rollers and wheels in the correct position for low transport.

B. Retract the Transport Cylinders (#3), fully raising the **complete rear section** (center & both wing sections).

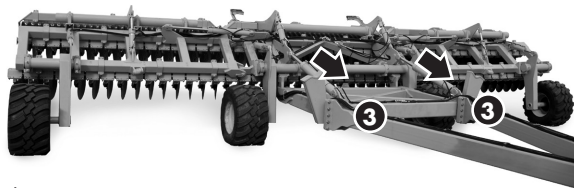

IMPORTANT: *Do Not* retract the wing cylinders to raise the wings at this point. Follow proper procedures to prevent possible equipment damage or failure.

NEVER LIFT WINGS!

Lift rear sections using the **Transport Cylinders (3)**, *then* fold the wings forward using the **Wing Cylinders (4)**.

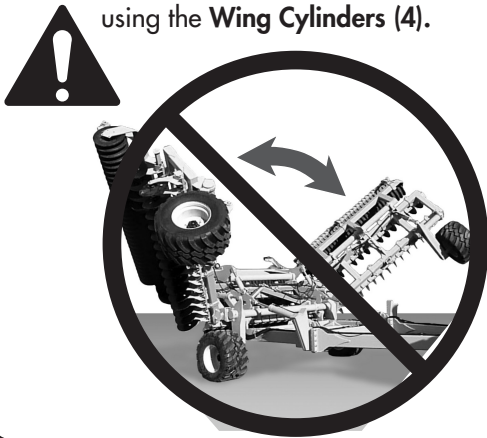

C. After raising all the rear sections together, retract the Wing Cylinders (#4) to bring both wings inward towards the frame.

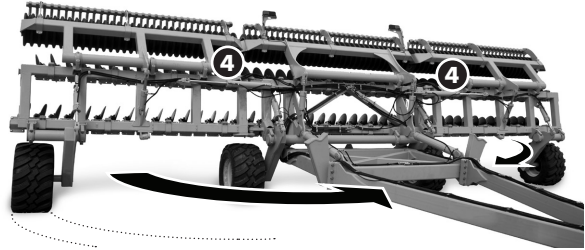

D. When the wings get close to the wing transport carriers, you may need to *slightly* extend the Transport Cylinders (#3) so the rollers can reach the correct position.

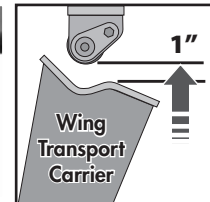
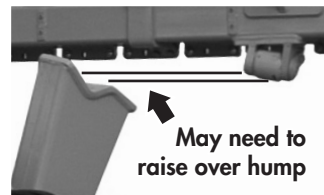

E. With the wings in the proper position, retract the Transport Cylinders (#3) fully lowering the wings onto the wing transport carriers.

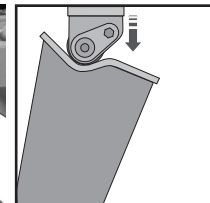
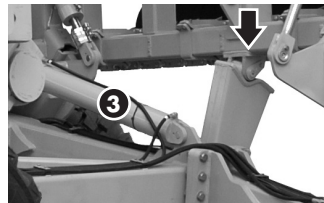

Operation

OPERATING SAFETY

1. Read and understand the Operator's Manual and all safety signs before using.
2. Stop tractor engine, set park brake, remove ignition key and wait for all moving parts to stop before servicing, adjusting, repairing or unplugging.
3. Keep hands, feet, hair and clothing away from all moving and/or rotating parts.
4. Do not allow riders on the Mach Till tractor during operation or transporting.
5. Keep all shields and guards in place when operating (if applicable).
6. Clear the area of all bystanders, especially children, before starting.
7. Do not operate machine on overly steep side hills or slopes.
8. Be careful when working around or maintaining a high-pressure hydraulic system. Ensure all components are tight and in good repair before starting.



BREAK-IN

Although there are no operational restrictions on the Mach Till when it is new, there are some checks that should be done when using the machine for the first time, follow this procedure:

IMPORTANT: It is important to follow the Break-In procedures especially those listed in the "Before using" section below to avoid damage:

A. Before using:

1. Read Safety Info. & Operator's Manual.
2. Complete steps in "Pre-Operation Checklist".
3. Lubricate all grease points.
4. Check all bolt tightness.
5. Confirm Ridge Wipers are installed in proper position after shipping and adjusted.
6. Adjust Disc Cutting Depth as outlined in the "Setting Disc Depth" section.

B. After operating for 2 hours:

1. Check all hardware. Tighten as required.
2. Check all hydraulic system connections. Tighten if any are leaking.

PRE-OPERATION CHECKLIST

It is important for both personal safety and maintaining good operational condition of the machine that the pre-operational checklist be followed.

Before operating the machine and each time thereafter, the following areas should be checked off:

1. Lubricate the machine per the schedule outlined in the "Maintenance Section".
2. Use only a tractor with adequate power to pull the Mach Till under ordinary operating conditions.

NOTE: It is important to pin the drawbar in the central location only.

3. Ensure that the machine is properly attached to the tractor using a clevis hitch, safety chain and a drawbar pin with provisions for a mechanical retainer. Make sure that a retainer such as a Klik pin is installed.

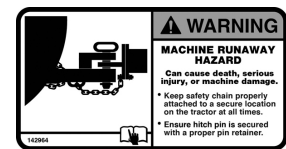

WARNING: Negative Hitch Weight may occur when raising or lowering the rear sections. If the unit is not properly attached to the tractor with a clevis hitch and safety chain, the negative hitch weight could result in the hitch pole to suddenly raise and the rear sections to come crashing down.



4. Before using, inflate tires to:

End Wheel Tires:
600/50 R22.5: **58 PSI (400 kPa)**

Center/Transport Tires (380 HD):
750/45 R22.5: **58 PSI (400 kPa)**

5. Check oil level in the tractor hydraulic reservoir. Top up as required.
6. Inspect all hydraulic lines, hoses, fittings and couplers for tightness. Tighten if there are leaks. Use a clean cloth to wipe any accumulated dirt from the couplers before connecting to the tractor's hydraulic system.
7. Inspect the condition/wear of the discs. If needed or desired, adjust the Disc Cutting Depth as outlined in the adjustments section. If excessive disc wear is evident, replacement may be required. Refer to maintenance section.

Operation

OPERATING GUIDELINES

1. Re-phase and cycle oil in the Depth Control Cylinders (Wheels #1 and Rollers #2) before use. This is especially important after long periods of storage.

2. Place the Transport Cylinders (#3) into the FLOAT position before operation.

⚠ IMPORTANT: The Transport Cylinders **MUST** be in the **FLOAT** position for the Mach Till to contour properly and to avoid possible cylinder or equipment damage.



⚠ IMPORTANT: Operator **must** read and understand the tractor manual in order to place the required hydraulic circuits into **float position**.

3. Wing Cylinders (#4): During operation, the wing circuit hydraulics need to be engaged **constantly** from the tractor, in the extended direction. This will ensure constant down pressure is applied to the wings and the machine can still contour over uneven terrain effectively.

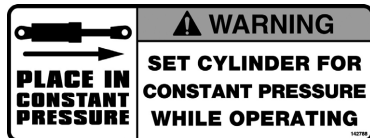

⚠ IMPORTANT: Operator **must** read and understand the tractor manual in order to place the required hydraulic circuits into **constant pressure position**, in the correct direction.

4. **IDEAL OPERATING SPEED** is 10-12 mph.

Minimum operating speed is 8 mph.

Maximum operating speed is 14 mph.

5. When making headland turns, the operator may wish to slightly raise the disc sections by activating the Wheel (#1) or Roller (#2) cylinders (or both). Remember to lower after coming out of the turn.

6. Each time you start a new field you may need to adjust the cutting depth depending on the type of crop residue or soil conditions. The operator can adjust the cutting depth by raising/lowering the front or rear sets of discs by following the guidelines in the "Setting Disc Depth" section.

7. After making adjustments to the cutting depth it is recommended to bring the Mach Till up to speed (10-12mph) to test the depth setting by driving about 100m (cutting performance changes dramatically from a slow speed to high speed). Stop, check depth and cut of field, re-adjust the height higher or lower, if needed, based on your preference. Remember: Removing a 1/4" stop lowers cutting depth 1/2" deeper, Adding a 1/4" stop raises discs up 1/2" higher.

8. Harder, packed soil may require additional passes for optimum results. It is recommended to do a second pass at an angle to the original pass.

FACTORY DISK SETUP

20" Disc Setup

Mach Till 412

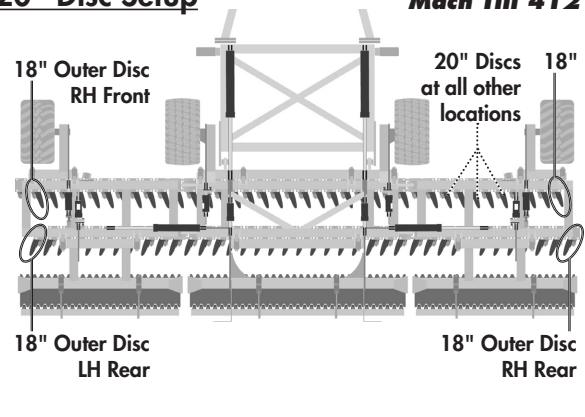

22" Disc Setup

Mach Till 412

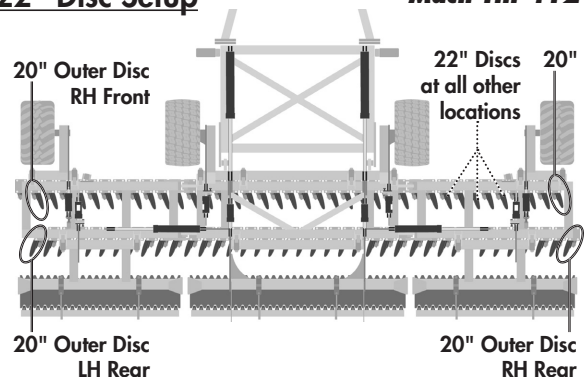

Operation

SETTING DISC DEPTH - FRONT AND REAR

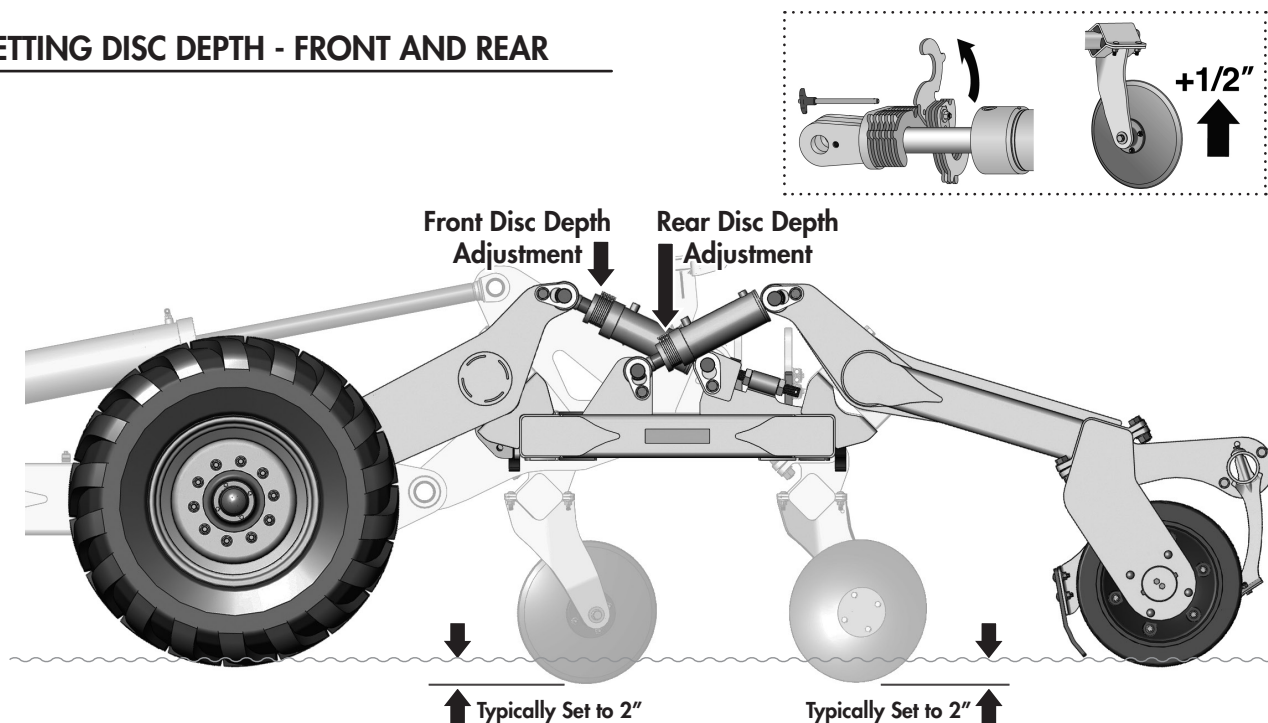

DEPTH SETTING OVERVIEW

Adjusting the cutting depth of the front and rear discs is accomplished by adding or removing a number of spacers from specified cylinders.

The spacers limit the stroke distance of the cylinders, changing the amount that the front and rear of the disc frames are lowered.

Each spacer that is added to the cylinders raises the frame height by 1/2". Therefore, to lower discs deeper into the soil, you would remove *one* spacer for *each* 1/2" of depth change required.

A typical recommended penetration depth of 2" is suggested for both front and rear discs. This depth, however, can be adjusted to the operators needs and preferences or based on different crop varieties and soil conditions.

Some operators may also prefer to adjust the front or rear frame disc sections to run slightly higher than the other. Adjustments to the front or rear disc sections are done individually:

- Adjust the front disc height by adding/removing spacers to the two outer wing end wheel cylinders.
- Adjust the rear disc height by adding/removing spacers to the two outer rear wing roller cylinders.

NOTE: *As the discs wear with usage, the disc depth settings will also need to be adjusted accordingly.*

Use the following as a guideline for setting depth:

1. Drive the Mach Till onto level ground. For initial setup, try "12 Spacers" on each cylinder stop.
2. Fully retract the Wheel (#1) and Roller (#2) cylinders to lower rear frame to ground.
3. Check the penetration depth of the front and rear row of discs. Take note of how much you would like to raise or lower both the front and rear disc sections - round to the nearest 1/2".
4. Fully raise the frame back off the ground by extending the Wheel (#1) and Roller (#2) cylinders.
5. Adjust Front Disc height at the two outer wing end wheel cylinder positions.
Lower Front Discs - Remove one spacer for each 1/2" you want to Lower it.
Raise Front Discs - Add one spacer for each 1/2" you want to Raise it.
6. Adjust Rear Disc height from the two outer wing roller cylinders positions.
Lower Rear Discs - Remove one spacer for each 1/2" you want to Lower it.
Raise Rear Discs - Add one spacer for each 1/2" you want to Raise it.
7. Repeat above procedure until proper depth is achieved.

Operation

WING FRAME OUTER END ADJUSTMENT

Some operators may prefer to adjust the outer wing frame depth if they find that it is running deeper or shallower than the level of the center frame. There is a threaded rod on the End Wheel Cylinder (both LH and RH sides) that will allow adjustments to this height:

- Lengthening adjustment rod length:
 - Raises the outer wing
- Shortening adjustment rod length:
 - Lower the outer wing

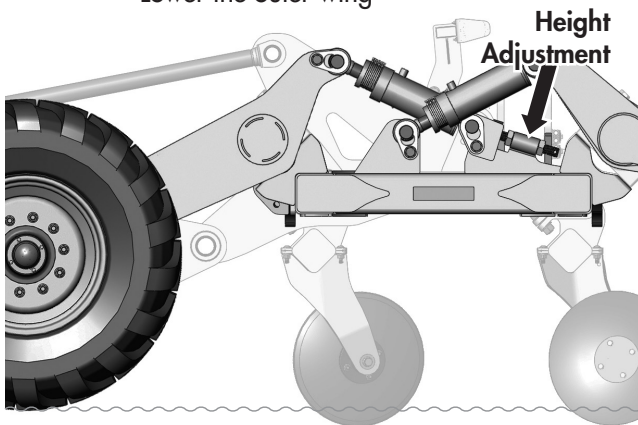

PROCEDURE TO SET DEFLECTOR HEIGHT:

⚠ IMPORTANT: You may need to adjust the deflector height according to soil penetration. Best setting is when deflector runs just slightly above the ground.

The following is a recommended procedure to set the height of the dirt deflector:

- 1 - Run the machine with discs set to the proper depth.
- 2 - Stop the machine.
- 3 - Adjust the height so the deflector is running just slightly above the ground.

SETTING DIRT DEFLECTOR ARM DISTANCE

The *Dirt Deflector Arm* has multiple extension settings. The position can be adjusted to the operator's preference depending on the disc/frame pitch settings and soil conditions. For example, if the deflector is plugging or restricting the flow of dirt and trash, you may wish to move the deflector arm outward.

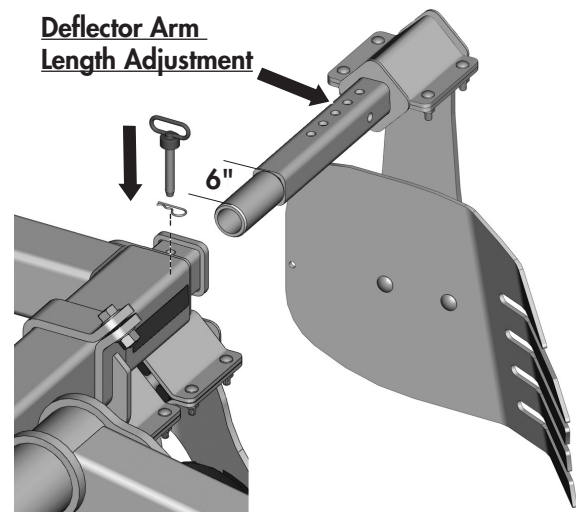

DISENGAGING THE DIRT DEFLECTOR

The Dirt Deflector may be rotated into a disengaged position by following these simple instructions:

- Remove the pin securing the deflector arm.
- Pull out the deflector arm only far enough to where the round pipe is connected to the square tube.
 - (Note: The round pipe section is only 6" long. If you pull it out too far, it will fall out.)
- Rotate the deflector arm upward to either the 90° or 180° position, as desired. (See Below)
- Re-install the pin to secure deflector arm in place.

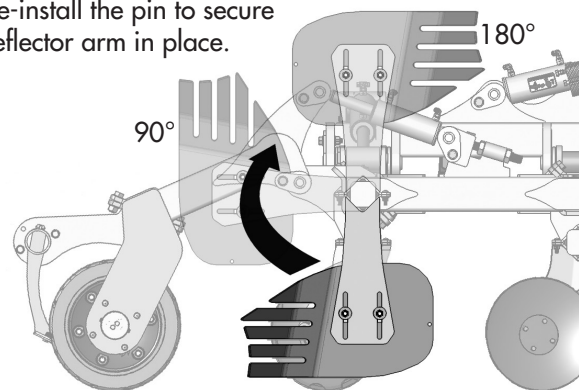

If preferred, the deflector arm could also be completely removed and stored by pulling the pin and removing.

Operation

SCRAPER POSITION OVERVIEW

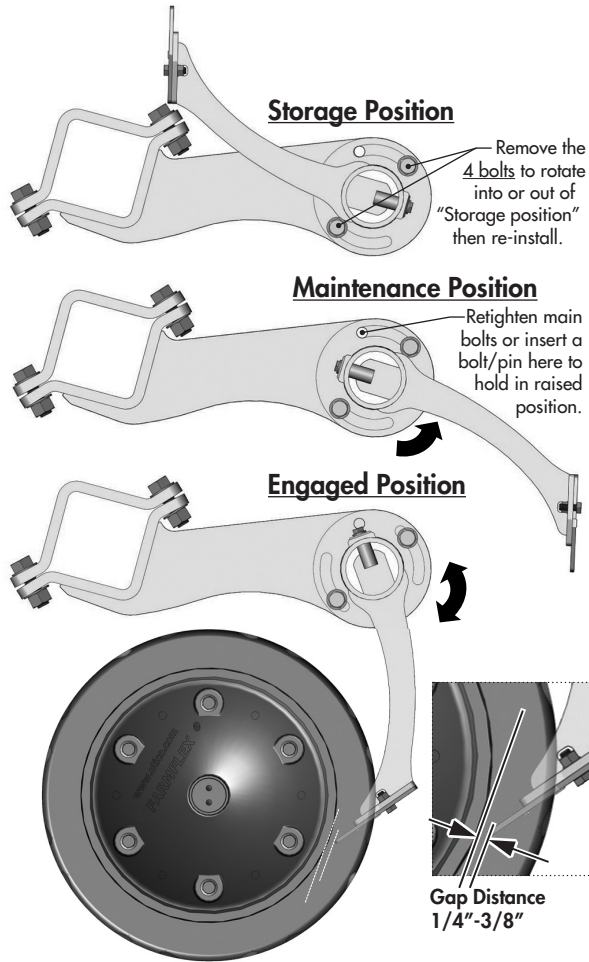

SCRAPER SIDE-TO-SIDE POSITIONING

Inspect that the scraper plates are as close to centered as possible in the roller groove & that no scrapers are touching the sides of the rubber roller. (Ideally there should be a 1/4" gap)

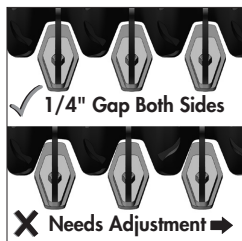

If adjustment is needed, loosen the scraper arm clamps and adjust position until there is proper clearance on all edges. You may need to slightly adjust engagement distance if side-to-side is unsuccessful.



SETTING SCRAPER POSITION

Change into Storage Position:

- Loosen & remove the 4 bolts (2 per arm).
- Rotate section upward to new position.
- Reinstall bolts and tighten in place.
- Reverse procedure to put into working position.

Change into Maintenance Position (from engaged):

- Loosen the 4 bolts (2 per arm).
- Rotate section upward until top hole is open.
- Tighten bolts to secure and/or insert bolt or insert pin (user supplied) into top hole to secure in position.

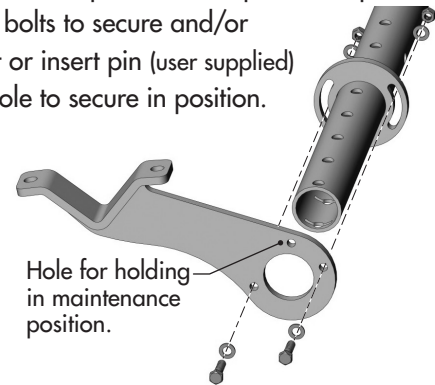

Change into Engaged Position (from maintenance):

- Loosen the 4 bolts (2 per arm).
- Rotate section down until scraper blades are set to proper distance from inner roller groove. (1/4" to 3/8" is the recommended distance)
- Tighten bolts to secure in position.

INDIVIDUAL SCRAPER ARM ADJUSTMENT

The individual scraper arm position can also be fine tuned by loosening the top mounting bolt, adjusting the position, and then "holding in place" while re-tightening the bolt.

Loosen the top bolt to adjust, then hold in place while re-tightening.

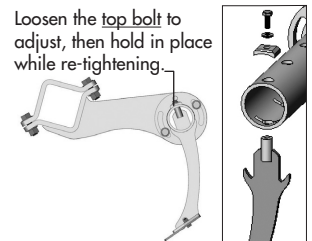

REVERSING SCRAPER BLADES

The scraper blades are designed to be reversible in order to provide extended wear. It is advised to reorder replacement blades soon after reversing to prevent possible downtime in the future.

Double Sided Scraper Blades
Note: When blades are being reversed, the complete section must be changed at the same time or adjustment will not work properly.



Troubleshooting - Mach Till 412

Plugging disc rows in wet conditions:

- Ensure roller is turning & scrapers are set properly.
- Raise machine working depth.
- Increase operating speed slightly.
- Adjust pitch so front discs are slightly higher (add one more depth stop plate to wheel cylinders).
- Fully extend wheel & roller depth cylinders & hold for 30 seconds to re-phase.
- Check condition & operation of disc hubs (make sure they turn freely).
- Wait for soil conditions to dry out more.

Roller skidding in wet conditions:

- Check scraper operation & settings.
- Raise machine working depth.
- Adjust pitch so rear discs are slightly higher & raise machine working depth.
- Momentarily take out of float & extend transport cylinders to simulate a rigid hitch (**flat ground only**). **Re-engage float** as soon as possible to avoid possible equipment damage.
- Wait for soil conditions to dry out more.
- Check condition & operation of bearings on both ends of the rollers.

Mud not clearing from rubber rollers:

- Check scraper to roller distance & adjust if necessary (scraper should be 1/4" to 3/8" from roller).
- Check scraper plate wear & adjust or replace as necessary (replace all scrapers per row at the same time).
- Check scraper row adjustment for slippage & re-torque or replace hardware if necessary.

Roller plugged in wet conditions:

- Retract transport cylinders to pass over pushed up mound & smooth out when soil dries.
- Raise discs all the way up & drive 12-14 mph on firm soil to clear rollers.
- In certain wet soil conditions place scrapers in storage position to continue operating.
- If plugging persists wait for soil conditions to dry out even more.

Rear discs or roller not engaging in very hard soil:

- Adjust pitch so front discs are higher by adding two depth stops or more to wheel cylinders only (It may be necessary to lower overall machine depth also).
- Momentarily take out of float & extend transport cylinders to simulate a rigid hitch (**flat ground only**). **Re-engage float** as soon as possible to avoid possible equipment damage.

Not folding up for transport:

- Ensure hydraulic coupler has not disengaged or try a different tractor hydraulic port.
- Check for hose or fitting leaks.
- Tractor hydraulic system should have 2800 psi.
- Hydraulic fluid bypassing piston seals in one or both hydraulic cylinders. (Replace cylinder or re-build with new seals).
- Excessive mud built up on frame & rollers. Clear off frame raise discs all the way up & drive 12-14 mph on firm soil to clear rollers.

Restriction or blocking on right side:

- Raise the deflector plate.
- Raise working depth of adjustable disc.
- Raise machine working depth.
- Reduce operating speed slightly.
- Extend right hand wheel adjustment to lift end of wing.
- Check condition & operation of disc hubs (make sure they turn freely).
- Wait for soil conditions to dry out more.

Leaving a ridge or a groove between rollers:

- Adjust ridge wiper down slightly to remove ridge.
- Adjust ridge wiper up slightly to eliminate groove.

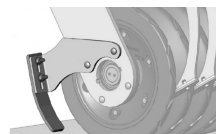

Tractor oil temperatures are too high:

- Lower the flow on the wing circuit hydraulic remote. (Please refer to the Tractor's Operators Manual)

Troubleshooting - Mach Till 412

Subsoil leaving a groove/ridge every 10":

- Adjust pitch to level machine (disc rows are not set to the same depth).
- Adjust pitch to lower/raise rear disc row (front is prone to running deeper with floating hitch & firm soil conditions).
- Rear discs following in front disc groove (see troubleshooting for this below).

End of wing discs cutting deeper or shallower than center:

- Fully extend wheel & roller depth cylinders & hold for 30 seconds to re-phase.
- Adjust the threaded rods on the end wheels:
 - Lengthen to lift end of wing if cutting deeper.
 - Shorten to lower end of wing if cutting shallower.
- Check for same number of depth control plates used on each side.

Rear discs following in front disc cut or discs not doing a full cut:

- Adjust tracking by changing implement pitch.
 - Adjust entire front row of disc gangs in small increments either left or right to achieve full cut.
 - Check disc wear & adjust gang spacing or replace discs as necessary (as discs wear move front row right).
 - Check factory settings on disc row locations to verify gang clamp hardware is tight & clamps have not slipped.
 - Adjust GPS to actual cutting width (see chart) minus 6" overlap per side depending on working depth.
- Note:** Also consider adjusting the GPS settings to include a 6" implement offset to the right.



(with 20" discs)	2" Depth	MAX Depth
Mach Till 412	491" (12.47m)	493" (12.52m)

- Adjust working angle to approximately 20 degrees to the right from previously worked or seeded rows.
(Recommended practice)

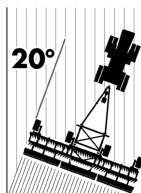

Leaving a ridge or a groove between passes:

- Adjust deflector up to reduce ridge.
- Adjust deflector down to fill groove.
- Set right rear adjustable disc lower if there is a ridge.
- Set right rear adjustable disc higher if there is a groove.
- Check that end disc size configuration matches factory suggested setup.
- Reduce implement width on guidance for slightly more overlap.

Tracking to the left:

- Add a depth stop to wheel cylinders to adjust the pitch so the front disc is higher.
- Reduce implement width on guidance system for slightly more overlap.
- Adjust implement offset on guidance system to the right.

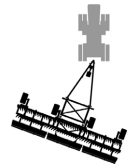

Tracking to the right:

- Add a depth stop to roller cylinders to adjust the pitch so the rear disc is higher.
- Reduce implement width on guidance system for slightly more overlap.
- Adjust implement offset on guidance system to the left.

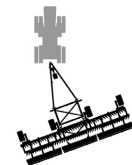

Hopping or leaving waves:

- Change operating speed (best performance is achieved over 10 mph).
- Change field working angle (best finishing at 5 to 20 degrees off previously worked).
- Adjust working depth (deeper & run slower or shallower to run faster).
- Pre-work heavy trash or wet areas at a slower speed & at a different angle than final pass.
- Wait for soil conditions to dry out more.
- Ensure the wing circuit hydraulic remote is constantly engaged in the extended direction.

Service & Maintenance

MAINTENANCE SAFETY

1. Review the Operator's Manual and all safety items before working with, maintaining or operating the Mach Till.
2. Stop the tractor engine, set park brake, remove ignition key and wait for all moving parts to stop before servicing, adjusting, repairing or unplugging.
3. Keep hands, feet, clothing and hair away from all moving and/or rotating parts.
4. Clear the area of bystanders, especially children, when carrying out any maintenance and repairs or making any adjustments.
5. Place safety stands or large blocks under the frame before removing tires or working beneath the machine.
6. Be careful when working around or maintaining a high-pressure hydraulic system. Wear proper eye and hand protection when searching for a high pressure hydraulic leak. Use a piece of wood or cardboard as a backstop when searching for a pin hole leak in a hose or a fitting.
7. Always relieve pressure before disconnecting or working on hydraulic system.
8. Never disconnect Mach Till from tractor if rear sections of machine are partially raised. See warning below:

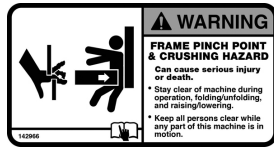

⚠ WARNING/DANGER: *Never disconnect Mach Till from tractor if rear sections of machine are partially raised. Negative Hitch Weight may result, the hitch pole may suddenly raise and the rear section would come crashing down. Only disconnect when unit is on level ground in the proper transport or field position.*

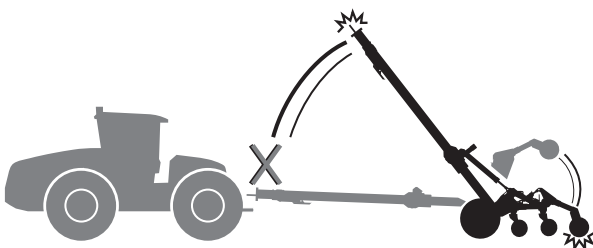

MAINTENANCE CHECKLIST

After reviewing the Maintenance and Hydraulic Safety Information, use the Maintenance Checklist provided for regular service intervals and keep a record of all scheduled maintenance:

(Initial break-in review. Read full section on pg.8)

A. Before using:

1. Read Safety Info. & Operator's Manual.
2. Complete "Pre-Operation Checklist"
3. Check all Bolt Tightness.
4. Adjust Disc Cutting Depth as outlined in the "Setting Disc Depth" section.

B. After operating for 2 hours:

1. Check all hardware. Tighten as required.
2. Check all hydraulic system connections. Tighten if any are leaking.

Maintenance Check - 10 Hours

- Check for worn or damaged parts
- Hydraulic fluid leaks
- Damaged hoses
- Check tire pressure:

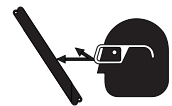

Center/Transport Tires (380 HD):
750/45 R22.5: **58 PSI (400 kPa)**



End Wheel Tires:
600/50 R22.5: **58 PSI (400 kPa)**

Maintenance Check - 50 Hours

- Grease hubs & spindles
- Check working points & pins
- Safety signs clean



Annually

- Bolt tightness
- Wheel bearings



Service & Maintenance

HARDWARE SPECIFICATIONS

Note: Unless stated otherwise, hardware is typically:
Hex, Plated GR5 UNC or P8.8 (metric)

TORQUE SPECIFICATIONS

Checking Bolt Torque

The tables below give correct torque values for various bolts and capscrews. Tighten all bolts to the torques specified in chart unless otherwise noted. Check the tightness of bolts periodically, using these bolt torque charts as a guide. Replace hardware with the same strength (Grade/Class) bolt.

IMPERIAL TORQUE SPECIFICATIONS

(Coarse Thread - based on "Zinc Plated" values)

Size		
	Grade 5 lb.ft (N.m)	Grade 8 lb.ft (N.m)
1/4"	7 (10)	10 (14)
5/16"	15 (20)	20 (28)
3/8"	25 (35)	35 (50)
7/16"	40 (55)	60 (80)
1/2"	65 (90)	90 (120)
9/16"	90 (125)	130 (175)
5/8"	130 (175)	180 (245)
3/4"	230 (310)	320 (435)
7/8"	365 (495)	515 (700)
1"	550 (745)	770 (1050)
1-1/8"	675 (915)	1095 (1485)
1-1/4"	950 (1290)	1545 (2095)
1-3/8"	1250 (1695)	2025 (2745)
1-1/2"	1650 (2245)	2690 (3645)

METRIC TORQUE SPECIFICATIONS

(Coarse Thread - based on "Zinc Plated" values)

Size		
	Class 8.8 lb.ft (N.m)	Class 10.9 lb.ft (N.m)
M6	7 (10)	10 (14)
M8	16 (22)	23 (31)
M10	30 (42)	45 (60)
M12	55 (75)	80 (108)
M14	90 (120)	125 (170)
M16	135 (185)	195 (265)
M18	190 (255)	270 (365)
M20	265 (360)	380 (515)
M22	365 (495)	520 (705)
M24	460 (625)	660 (895)
M27	675 (915)	970 (1315)
M30	915 (1240)	1310 (1780)
M33	1250 (1695)	1785 (2420)
M36	1600 (2175)	2290 (3110)

HYDRAULIC SAFETY

- Make sure that all components in the hydraulic system are kept in good condition and are clean.
- Replace any worn, cut, abraded, flattened or crimped hoses and metal lines.
- Do not attempt any makeshift repairs to the hydraulic lines, fittings or hoses by using tape, clamps or cements. The hydraulic system operates under extremely high-pressure. Such repairs will fail suddenly and create a hazardous and unsafe condition.
- Wear proper hand and eye protection when searching for a high-pressure hydraulic leak. Use a piece of wood or cardboard as a backstop instead of hands to isolate and identify a leak. 
- If injured by a concentrated high-pressure stream of hydraulic fluid, seek medical attention immediately. Serious infection or toxic reaction can develop from hydraulic fluid piercing the skin surface.
- Before applying pressure to the system, make sure all components are tight and that lines, hoses and couplings are not damaged.

HYDRAULIC HOSE SPECIFICATIONS

Note: Unless otherwise stated, Hydraulic Hoses are either 3/8 or 1/2 with 3/4 JIC/ORFS female swivel ends.

HYDRAULIC HOSE INSTALLATION TIPS

The following tips are to help you identify some possible problem areas in the installation of hydraulic hoses.

1. Ensure hoses are not twisted during installation as this may weaken the hose. Also, the pressure in a twisted hose may loosen fittings or connections.
2. Allow sufficient bend radius in hoses when installing to prevent lines from collapsing and flow becoming restricted.
3. When installing hoses in an area of movement or flexing, allow enough free length for motion and to ensure fitting connections are not stressed.
4. Ensure hoses are properly clamped and secured in position after routing is complete to provide a cleaner installation and prevent possible damage or hazards.

Service & Maintenance

HYDRAULIC FITTING INSTALLATION



The following info is to help you identify and properly install some of our standard hydraulic fittings.

SAE (JIC) 37° Flare

JIC fittings - Metal-to-metal sealing type fittings featuring a 37° flare (angle of sealing surface) and straight UNF (United National Fine) Threads.

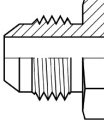
(Lubricated Values)	Dash	Thread Size	Torque - lb.ft (N.m)
	-4	7/16 - 20	9-12 (12-16)
	-6	9/16 - 18	14-20 (19-27)
	-8	3/4 - 16	27-39 (37-53)
	-10	7/8 - 14	36-63 (50-85)
	-12	1-1/16 - 12	65-88 (90-119)

Tightening JIC 37° Flare Type Fittings

1. Check flare and flare seat for defects that might cause leakage.
2. Align fittings before tightening. Lubricate connections & hand tighten swivel nut until snug.
3. Using two wrenches, torque to values shown in table.

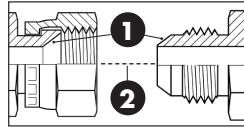

Alternate Installation Method

3. Using two wrenches. Place one wrench on the fixed connector body at a clock position of 6 o'clock.
4. Place the second wrench on the second connection as close to the 3 o'clock position as possible.
5. Tighten by rotating the second connection firmly to at least the 4 o'clock position, but no more than the 7 o'clock position. Typically, the larger the fitting size the less rotation required.

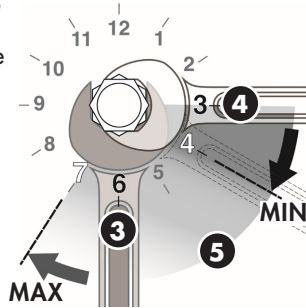

ORFS (O-Ring Face Seal)

ORFS fittings use an O-ring compression method to seal. This method offers a high level of sealing along with good vibration resistance. Male fittings include an O-ring located in a groove on the flat face. Female fittings feature a flat face and UNF straight threaded swivel nut.

The **Torque** method is recommended for ORFS installation.

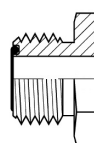
	Dash	Thread Size	Torque - lb.ft (N.m)
	-4	9/16 - 18	18 (25)
	-6	11/16 - 16	30 (40)
	-8	13/16 - 16	40 (55)
	-10	1 - 14	60 (80)
	-12	1-3/16 - 12	85 (115)

Tightening ORFS (O-Ring Face Seal) Fittings

1. Inspect components and ensure the O-Ring seal is undamaged and properly installed in the groove of the face seal. Replacing the O-Ring may be necessary.
2. Align, thread into place and hand tighten.
3. Tighten to proper torque from the table shown above.

Note: A **DASH** size refers to a diameter of a hose (*inside*) or of a tube (*outside*) measured in 1/16" increments. For example, a **Hose** specified as **dash 8** or **-8** would have an **inside** diameter of **8/16"** or **1/2"**. Alternatively, a **Tube** specified as **dash 8** or **-8** would have an **outside** diameter of **8/16"** or **1/2"**.

ORB (O-Ring Boss)

Male ORB fittings have straight UNF threads, a sealing face and an O-ring. The female fittings are generally found in the ports of machines and feature straight threads, a machined surface, and a chamfer to accept the O-ring. Sealing is achieved through the compression of the male O-ring against the chamfered sealing face of the female fitting.

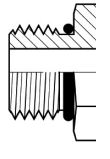
(Lubricated Values)	Dash	Thread Size	Torque	
			Non-Adjustable	Adjustable
	-4	7/16 - 20	30 (40)	15 (20)
	-6	9/16 - 18	35 (46)	35 (46)
	-8	3/4 - 16	60 (80)	60 (80)
	-10	7/8 - 14	100 (135)	100 (135)
	-12	1-1/16 - 12	135 (185)	135 (185)

Tightening ORB (O-Ring Boss) Fittings

Non-adjustable Port End Assembly

1. Inspect the components to ensure that male and female threads and sealing surfaces are free of nicks, burrs, scratches, or any foreign material.
2. Ensure O-Ring seal is properly installed and undamaged.
3. Lubricate threads and O-ring to help the O-ring slide past the port entrance corner and avoid damaging it.
4. Screw the fitting into position tighten to proper torque value from the table shown above.

Adjustable Port End Assembly

1. Inspect the components to ensure male & female threads and sealing surfaces are free of nicks, burrs, scratches, or any foreign material.
2. Ensure O-Ring seal is properly installed and undamaged.
3. Lubricate threads and O-ring to help the O-ring slide smoothly into the port and avoid damage.
4. Loosen back the lock nut as far as possible. Make sure back-up washer is not loose and is pushed up as far as possible.
5. Screw the fitting into port until the back-up washer or the retaining ring contacts face of the port. Light wrenching may be necessary. Over tightening may damage washer.
6. To align the end of the fitting to accept incoming tube or hose assembly, unscrew the fitting by the required amount, but not more than one full turn.
7. Using two wrenches, hold the fitting in desired position and tighten the locknut to the proper torque value from the table located above.
8. Inspect to ensure that O-ring is not pinched and that washer is seated flat on the face of the port.

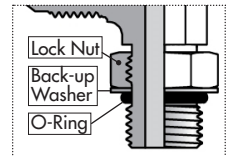

Service & Maintenance

WHEEL HUB REPAIR

DISASSEMBLY

1. Remove dust cap.
2. Remove cotter pin from nut.
3. Remove nut and washer.
4. Pull hub off spindle.
5. Dislodge the inner cone bearing and dust seal.
6. Inspect cups that are press fitted into hub for pits or corrosion and remove if necessary.
7. Inspect and replace defective parts with new ones.

IMPORTANT: Be sure to block up unit securely before removing tires.

COMMON HUB & SPINDLE COMPONENTS



Spindle



Dust Seal



Inner Cone



Inner Cup

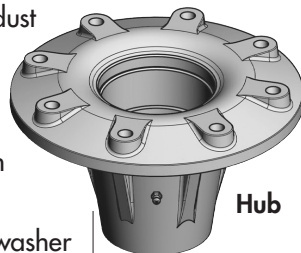

Hub



Outer Cup



Outer Cone



Flat Washer



Slotted Nut & Cotter Pin



Dust Cap

ASSEMBLY

1. If cups need replacing, be careful to install them gently and evenly into hub until they are fully seated.
2. Apply a thick wall of grease inside hub. Pack grease in cones.
3. Install inner cone and dust seal as illustrated.
4. Position hub onto spindle and fill surrounding cavity with grease.
5. Assemble outer cone, washer and nut.
6. Tighten nut while rotating hub until there is a slight drag.
7. Turn nut back approximately 1/2 turn to align cotter pin hole with notches on nut.
8. Install cotter pin and bend legs sideways over nut.
9. Fill dust cap half full of grease and gently tap into position.
10. Pump grease into hub through grease fitting until lubricant can be seen from dust seal.

WHEEL NUT & WHEEL BOLT TORQUE



TORQUE

BOLT PATTERNS



5 BOLT PATTERN



6 BOLT PATTERN



8 BOLT PATTERN

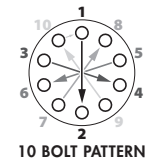

10 BOLT PATTERN

Wheel Nut/Bolt Torque

Size	lb.ft	(N.m)
9/16	120-130	(165-175)
5/8	185-190	(250-260)
3/4	280-300	(380-405)

Wheel Tightening Procedure

1. Install and **hand tighten** nuts/bolts.
2. Tighten to approx. **20% Torque** value using the Bolt **Star** or **CrissCross** patterns shown above.
3. Tighten to **Full Torque** value using the **Star** or **CrissCross** pattern.
4. If applicable, install **Rear Locknuts** using **Wheel Torque Values**.

STORAGE

The Mach Till should be carefully prepared for storage to ensure that all dirt, mud, debris and moisture has been removed.

Follow this procedure when preparing to store:

1. Wash the entire machine thoroughly using a water hose or pressure washer to remove all dirt, mud, debris or residue.
2. Inspect all parts to see if anything has become entangled in them. Remove entangled material.
3. Lubricate hub and spindle grease fittings to remove moisture
4. Inspect all hydraulic hoses, fittings, lines and couplers. Tighten any loose fittings. Replace any hose that is badly cut, nicked or abraded or is separating from the crimped end of the fitting.
5. Touch up all paint nicks and scratches to prevent rusting.
6. Select an area that is dry, level and free of debris.
7. Store in either Transport or Field position.
8. Use hydraulic cylinder jack.
9. Oil any exposed chrome shafts on the hydraulic cylinders to prevent rusting.

Service & Maintenance

HYDRAULIC CYLINDER REPAIR

PREPARATION

When cylinder repair is required, clean off unit, disconnect hoses and plug ports before removing cylinder.

When removed, open the cylinder ports and drain the cylinder's hydraulic fluid.

Examine the type of cylinder. Make sure you have the correct tools for the job.

You may require the following tools:

- Proper **Seal Kit**
- Rubber Mallet
- Screwdriver
- Punch
- Pliers
- Emery cloth
- Torque Wrench

Types of Cylinders (Wire Ring / Threaded Head)

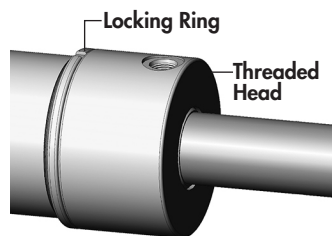
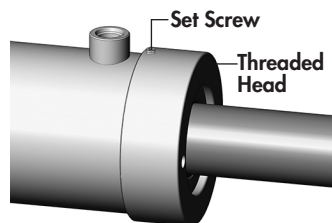
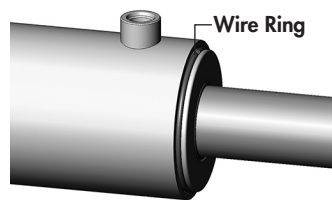

REPAIRING A WIRE RING CYLINDER

1. Retract the rod assembly.
2. Remove the external steel wire ring.

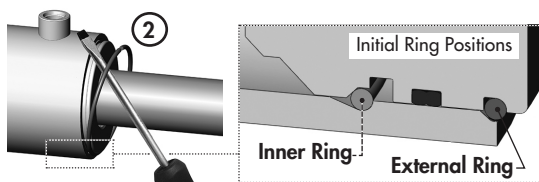

3. Remove any dirt that may have accumulated on the cylinder head.

4. Using the mallet and punch, push the head into the cylinder tube until the internal tube groove is fully exposed. This will also move the internal wire ring into its removal position.

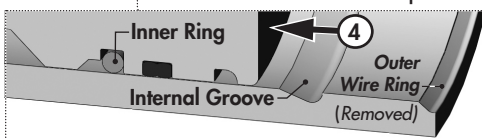

5. Take the plastic removal ring from the seal kit:
 - a) Straighten the ring and remove any kinks or excessive curl to make installation easier and prevent it from falling out.
 - b) Insert the removal ring into the internal groove with the feathered end pointing into the tube.

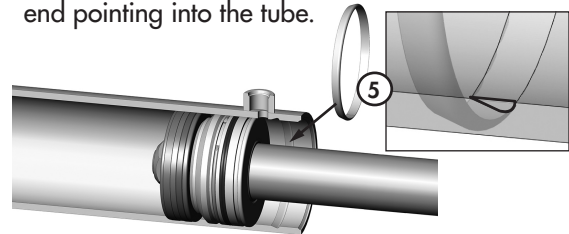

- c) Use a screwdriver or a finger to hold one end of the ring in the groove while fitting the other end of the ring into the groove. The tips should snap in together. Ensure it is secure and fully seated before the next step.

IMPORTANT: It is important to ensure the removal ring is completely in the groove before pulling the rod out. If the ring sticks out it will get stuck between the head and tube.

6. a) Extend the rod to pull the head out of tube. If the rod does not pull out easily, push the head back in and ensure the ring is properly in the groove. Replace ring if necessary.

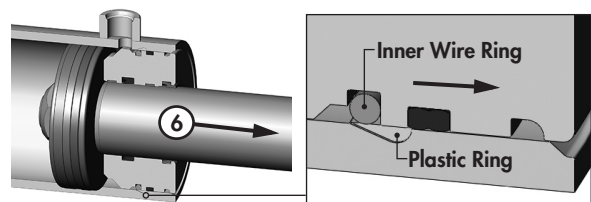

Note: Excessive force will not overcome a jammed ring and could damage the cylinder.

- b) Completely remove rod and head from tube.

7. Remove plastic removal ring from the cylinder tube.

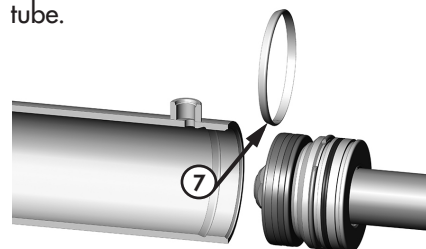

Service & Maintenance

REPLACING A PRESSED BUSHING

NOTE: You may need the following tools:
Press, hammer, punch, pry-bar, "Step-Tool"

Use the following as a guideline for repair:

1. Ensure the area and frame are properly secured, supported, and safe to work on. Safely remove the pin(s), cylinder, and/or components necessary in order to access and work on the damaged bushing.
2. Remove the existing bushing using required tools. In some instances, you may need to cut the damaged bushing in order for easier removal (use proper safety precautions and try not to damage other components if using this method).
3. With the bushing removed, clean and prepare the location for the new bushing insert. **Note:** A mixture of "Dish Soap and Water" is recommended to use as a lubricant on the outside of the composite bushing.

⚠ IMPORTANT: DO NOT use oil or grease on outside or inside of composite bushings.

4. Use a stepped tool to ensure the edge of the bushing is not damaged when inserting.

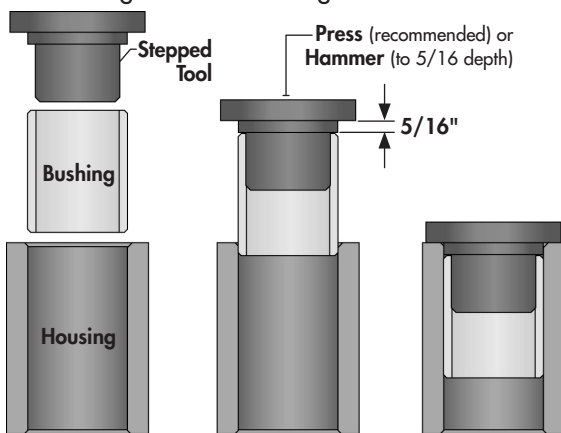

5. Ensuring the bushing is properly aligned, press into hole (preferred method) or hammer into position by striking the stepped tool.
6. Continue to install until the bushing edge is recessed in to a distance of 5/16" to allow for the outer seal to be properly installed. Do not exceed this depth.
7. Repeat steps 4-6 for opposite bushing (if applicable).

8. When both bushings are installed to the proper depth, install the new seals.
9. Re-assemble all other necessary components.

⚠ IMPORTANT: DO NOT use oil or grease on pins or bushing surfaces when re-installing.

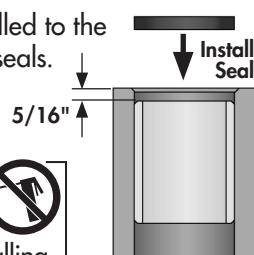

Service & Maintenance

SAFETY DECALS & REFLECTORS

Keep safety decals and signs clean and legible at all times. Replace safety decals and signs that are missing or have become illegible. Safety decals or signs are available from your Dealer Parts Department.

DECAL LOCATION OVERVIEW

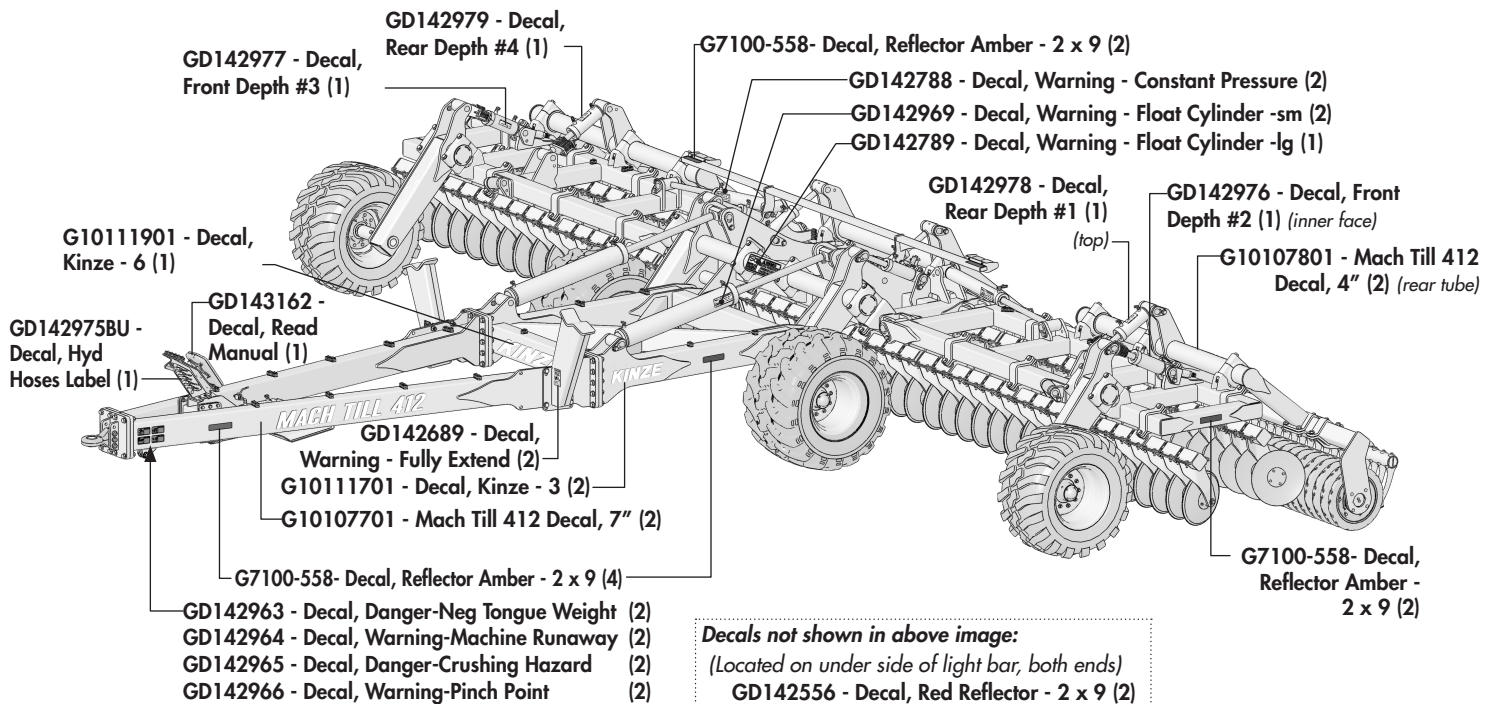

Decals not shown in above image:
 (Located on under side of light bar, both ends)
 GD142556 - Decal, Red Reflector - 2 x 9 (2)
 GD142650 - Decal, Fluorescent - 2 x 9 (2)
 (Located on rear center Roller Frame)
 G10111701 - Decal, Kinze - 3 (1)

GD143162 - Decal, Read Manual	(1)
GD142963 - Decal, Danger-Neg Tongue Weight	(2)
GD142964 - Decal, Warning-Machine Runaway	(2)
GD142965 - Decal, Danger-Crushing Hazard	(2)
GD142966 - Decal, Warning-Pinch Point	(2)
GD142789 - Decal, Warning-Float Cylinder-lg	(1)
GD142969 - Decal, Warning-Float Cylinder-sm	(2)
GD142788 - Decal, Warning-Constant Pressure	(2)
GD142689 - Decal, Warning-Fully Extend	(2)
GD142556 - Decal, Reflector Red - 2 x 9	(2)
G7100-558 - Decal, Reflector Amber - 2 x 9	(8)
GD142650 - Decal, Fluorescent - 2 x 9	(2)
GD142975BU - Decal, Hydraulic Hose Label	(1)
GD142976 - Decal, Front Disc Depth #2	(1)
GD142977 - Decal, Front Disc Depth #3	(1)
GD142978 - Decal, Rear Disc Depth #1	(1)
GD142979 - Decal, Rear Disc Depth #4	(1)
G10111701 - Decal, Kinze - 3"	(3)
G10111901 - Decal, Kinze - 6"	(1)
G10107801 - Decal, Mach Till 412 - 4"	(4)
G10107701 - Decal, Mach Till 412 - 7"	(2)

Mach Till Overview

Exploded Overview of Mach Till 412

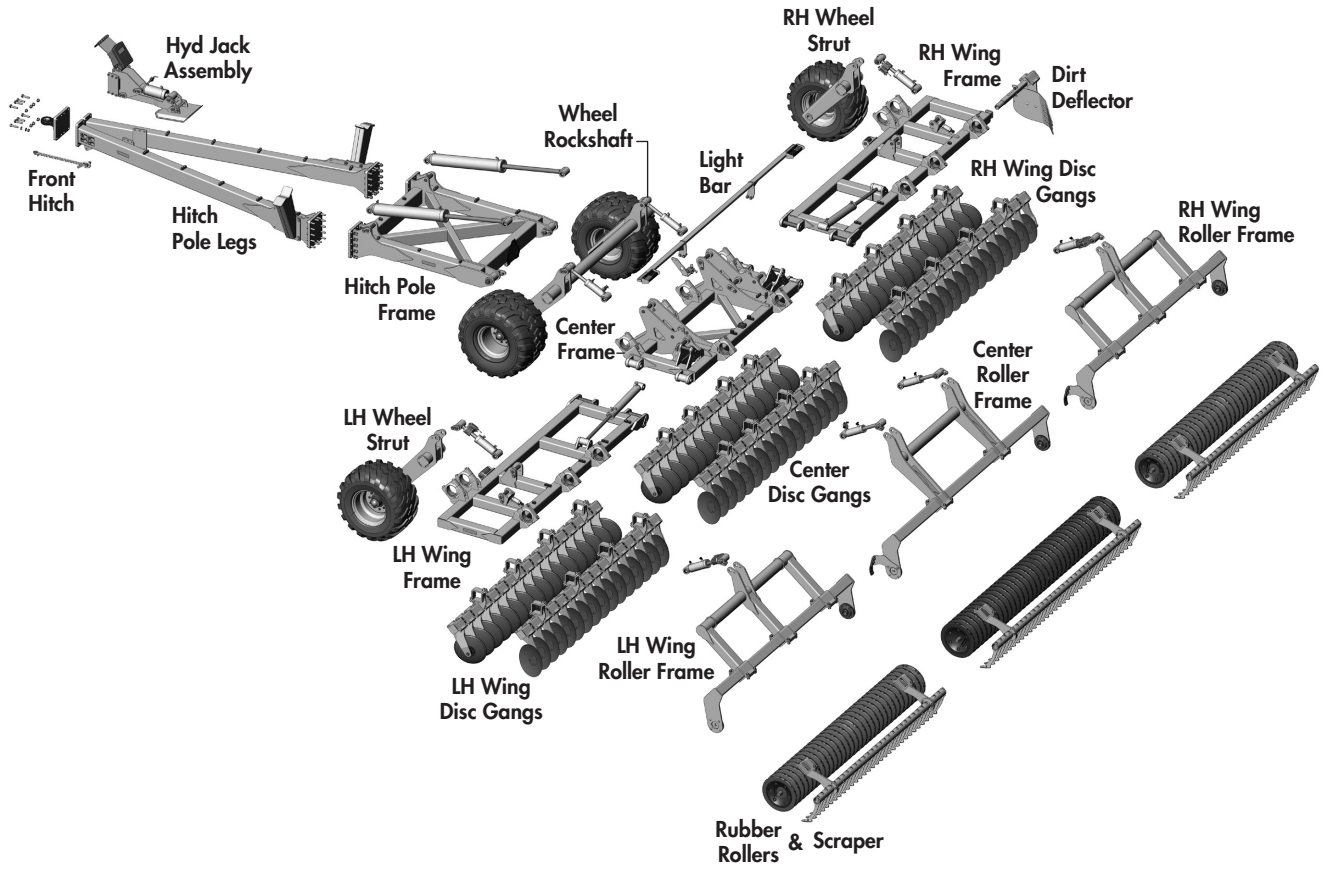

Hitch Pole / Front Frame Components

Hitch Pole/Front Frame Overview

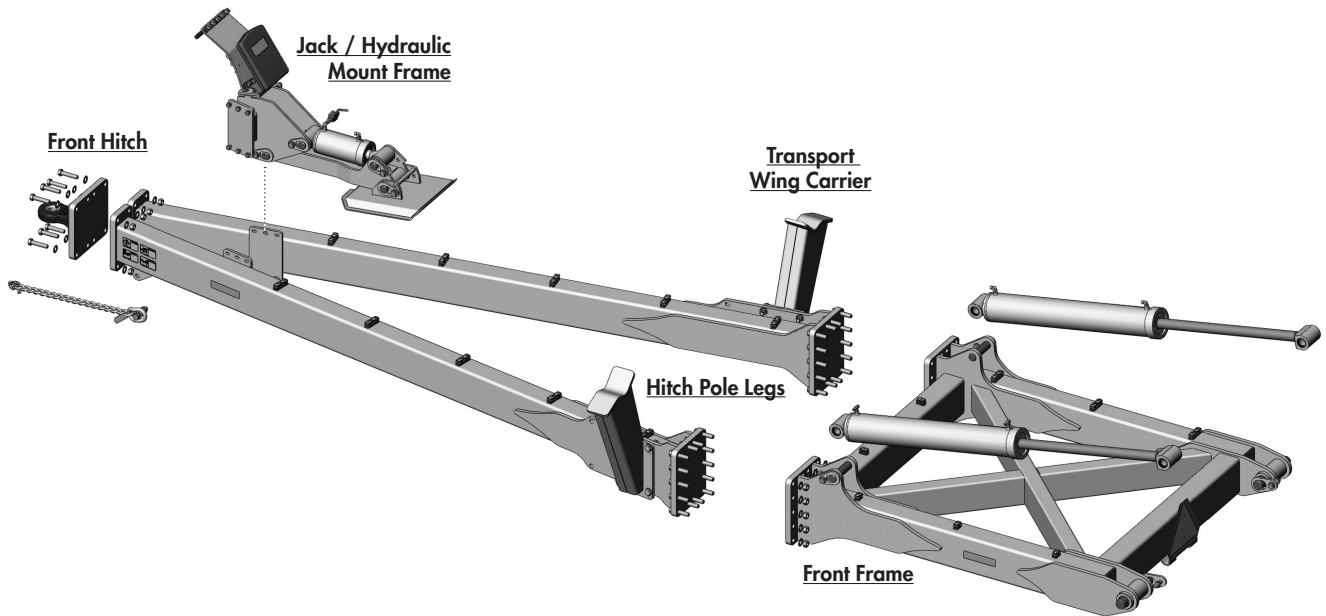

Hitch Pole Leg Components

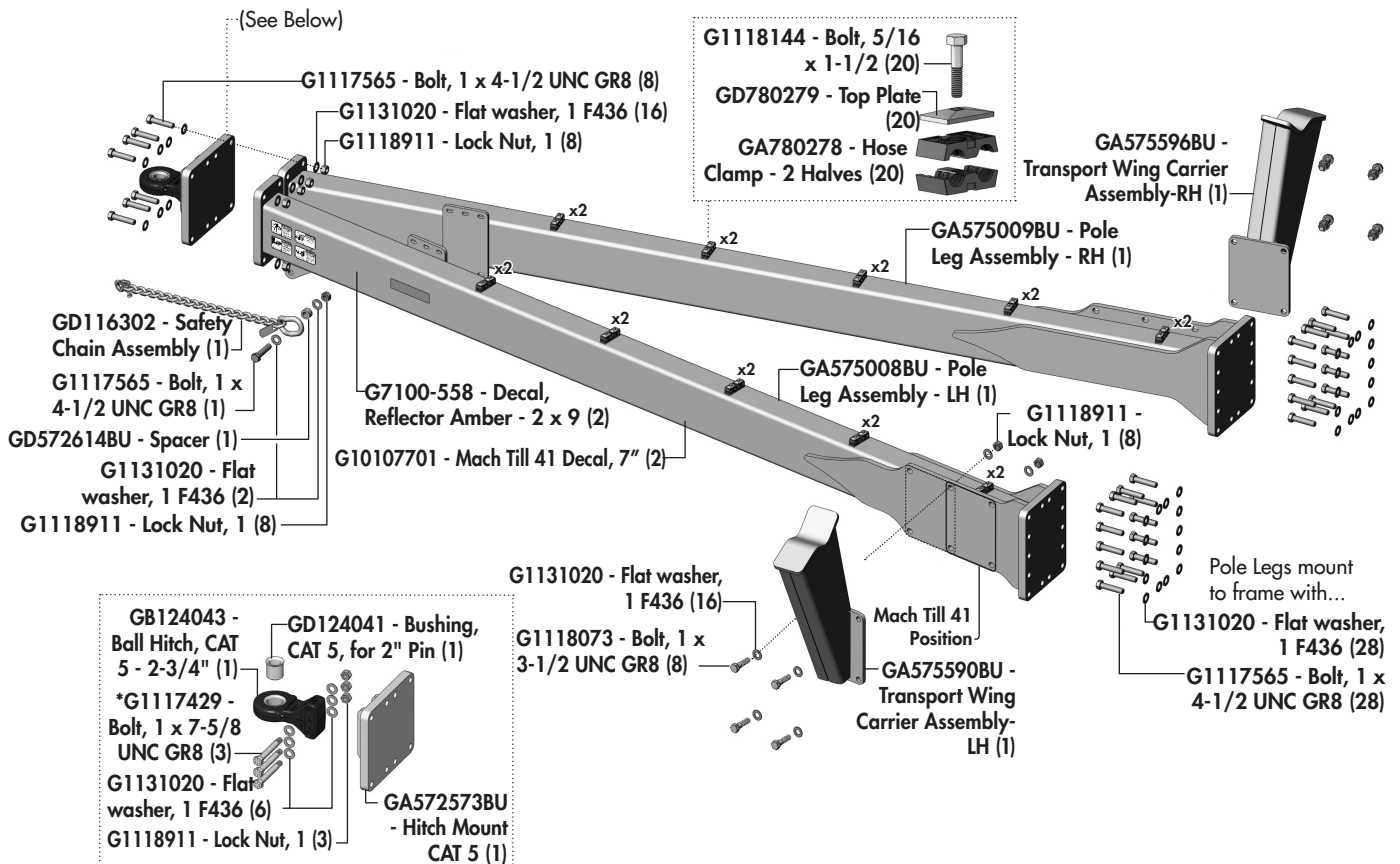

* When G1117429 is purchased, it will also come w/quantity 1 of G1131020.

Hitch Pole Frame Components

Jack/Hydraulic Mount Frame Detail

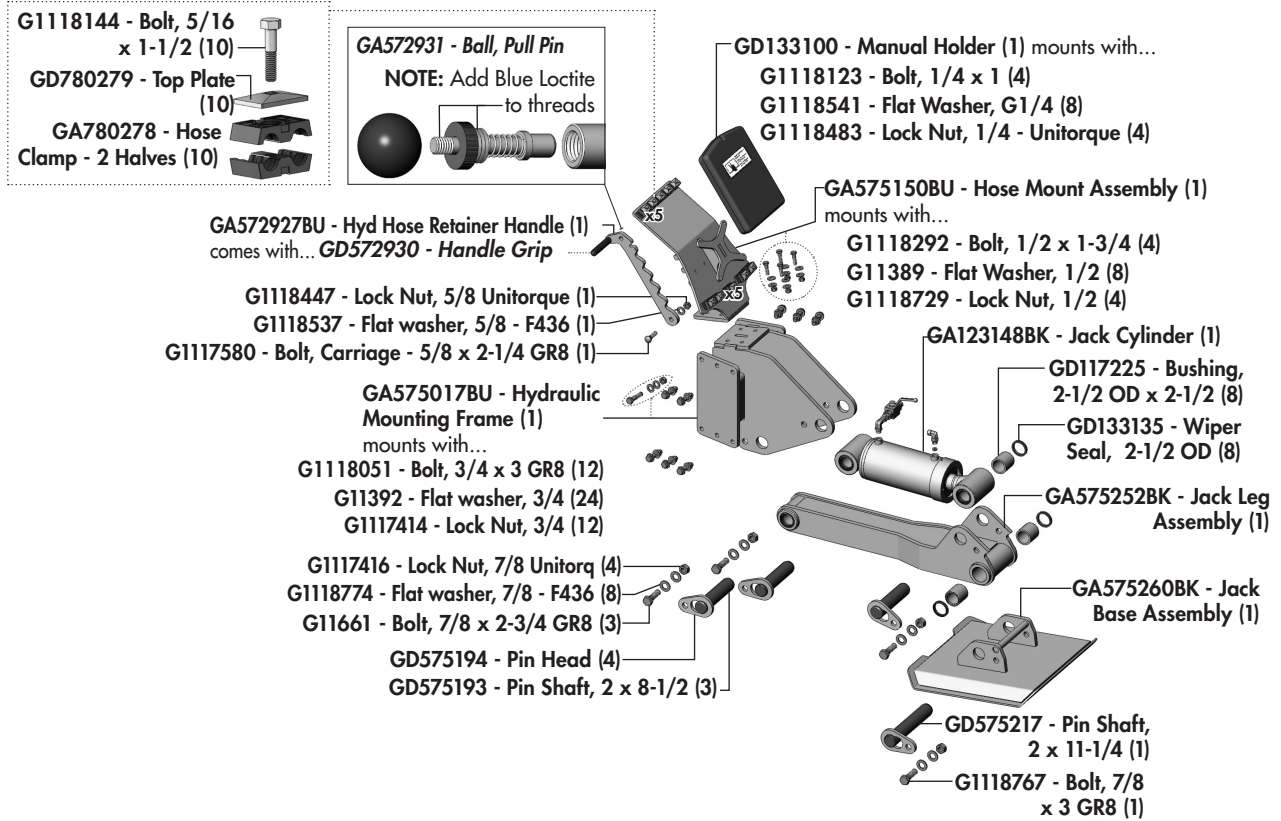

Front Frame Components

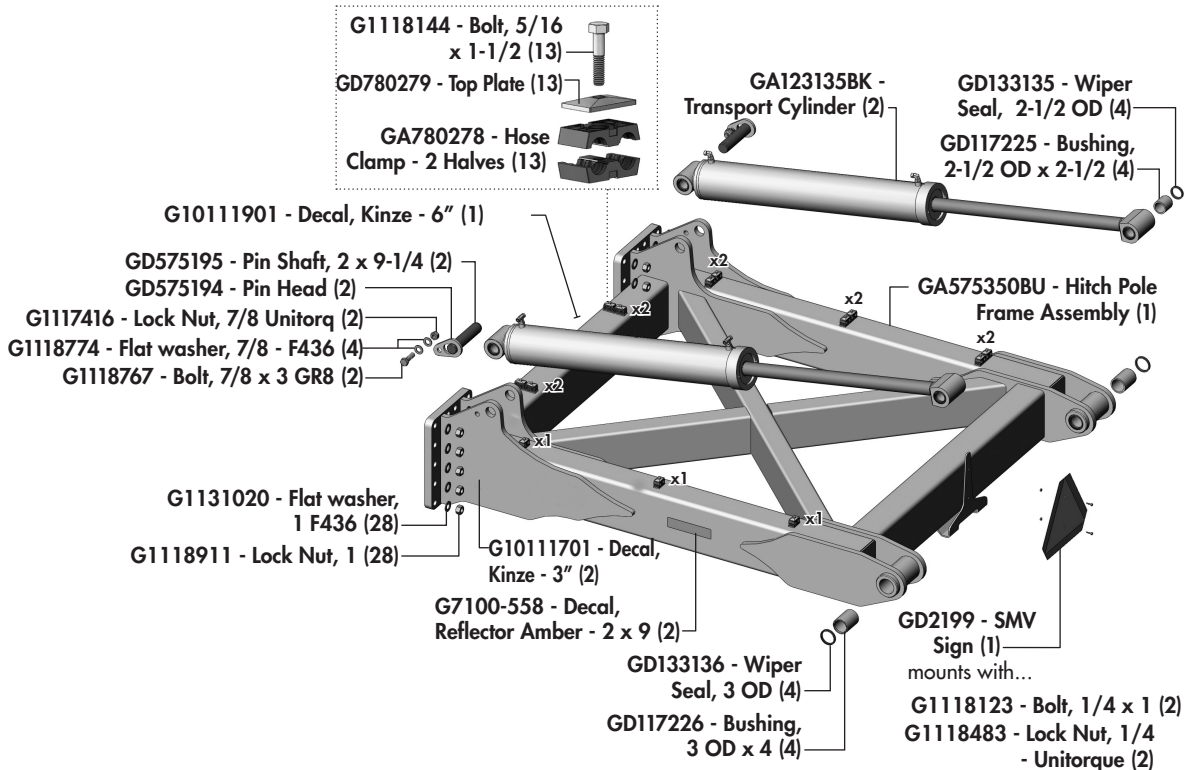

Wheel & Rockshaft Components

Rockshaft & Wheel Components

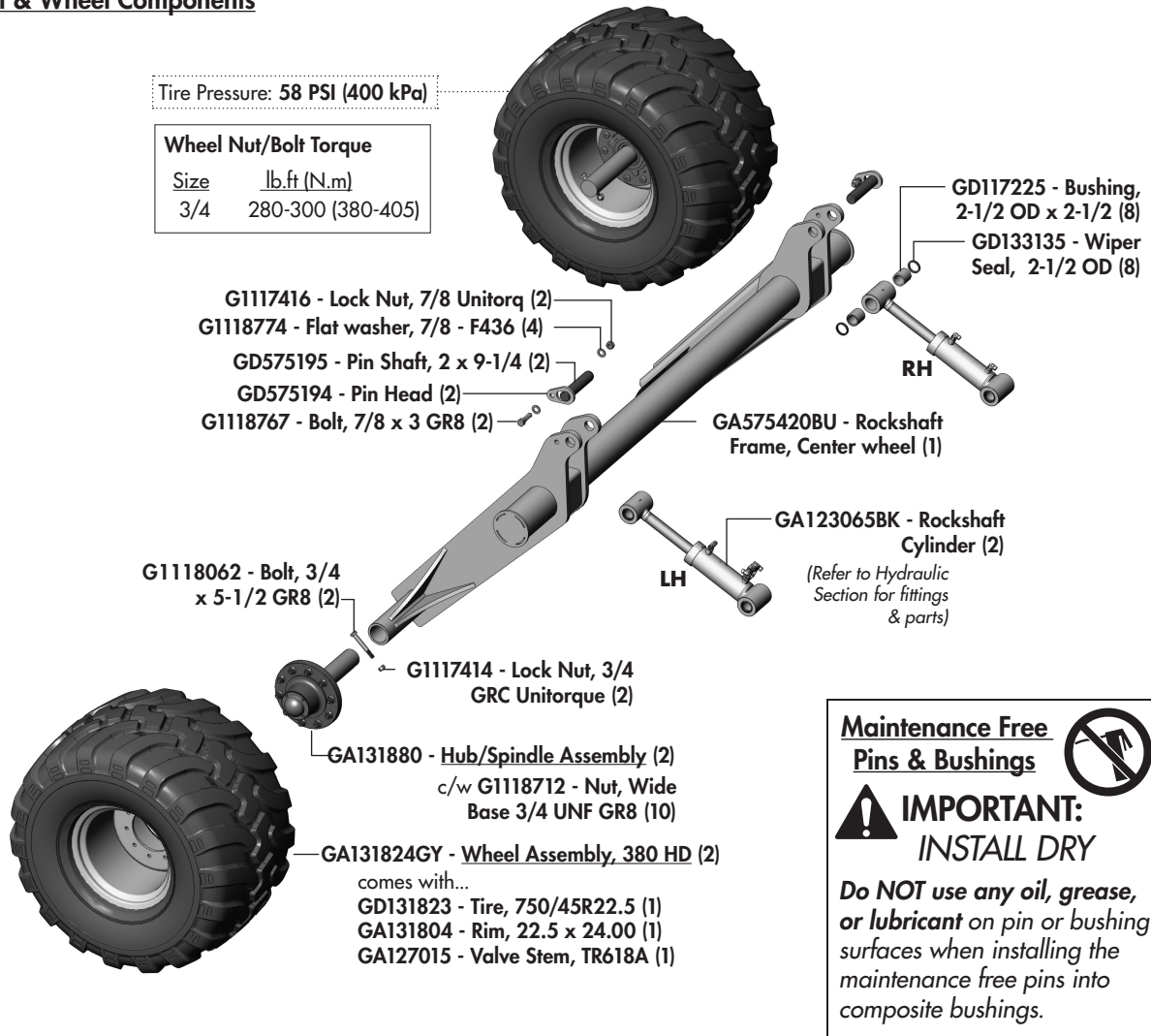

Maintenance Free Pins & Bushings 

IMPORTANT: INSTALL DRY

Do NOT use any oil, grease, or lubricant on pin or bushing surfaces when installing the maintenance free pins into composite bushings.

GA131880 - Hub/Spindle Assembly (2)

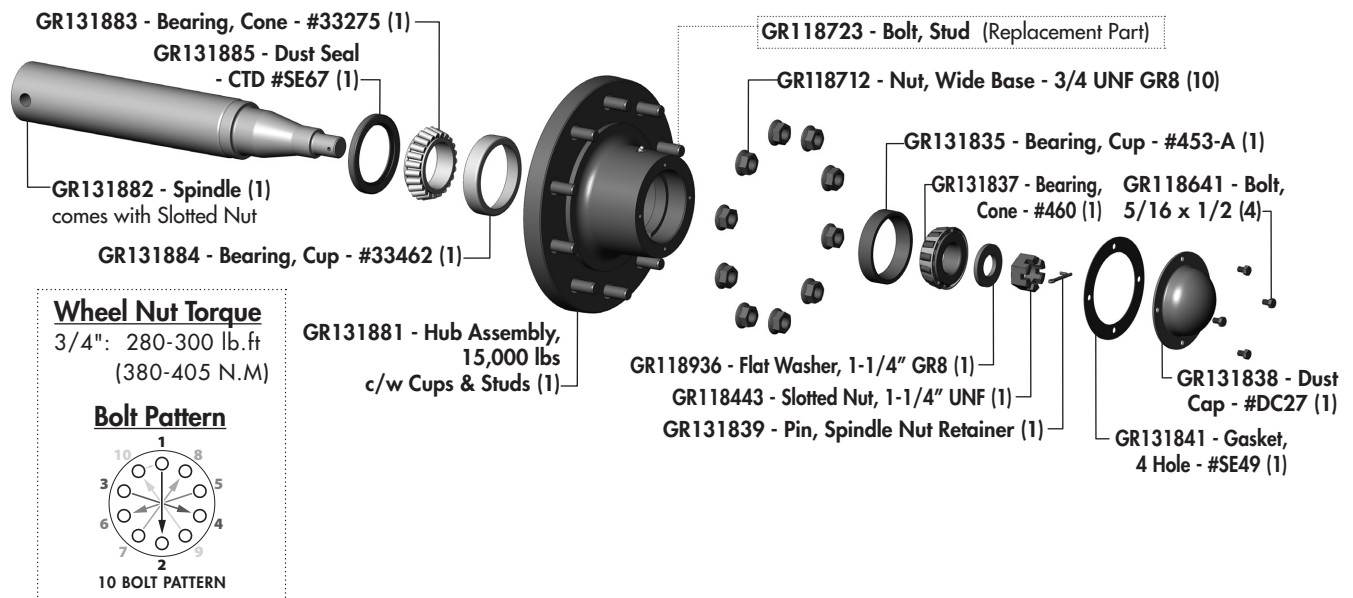

Center Frame Components

Center Frame Components

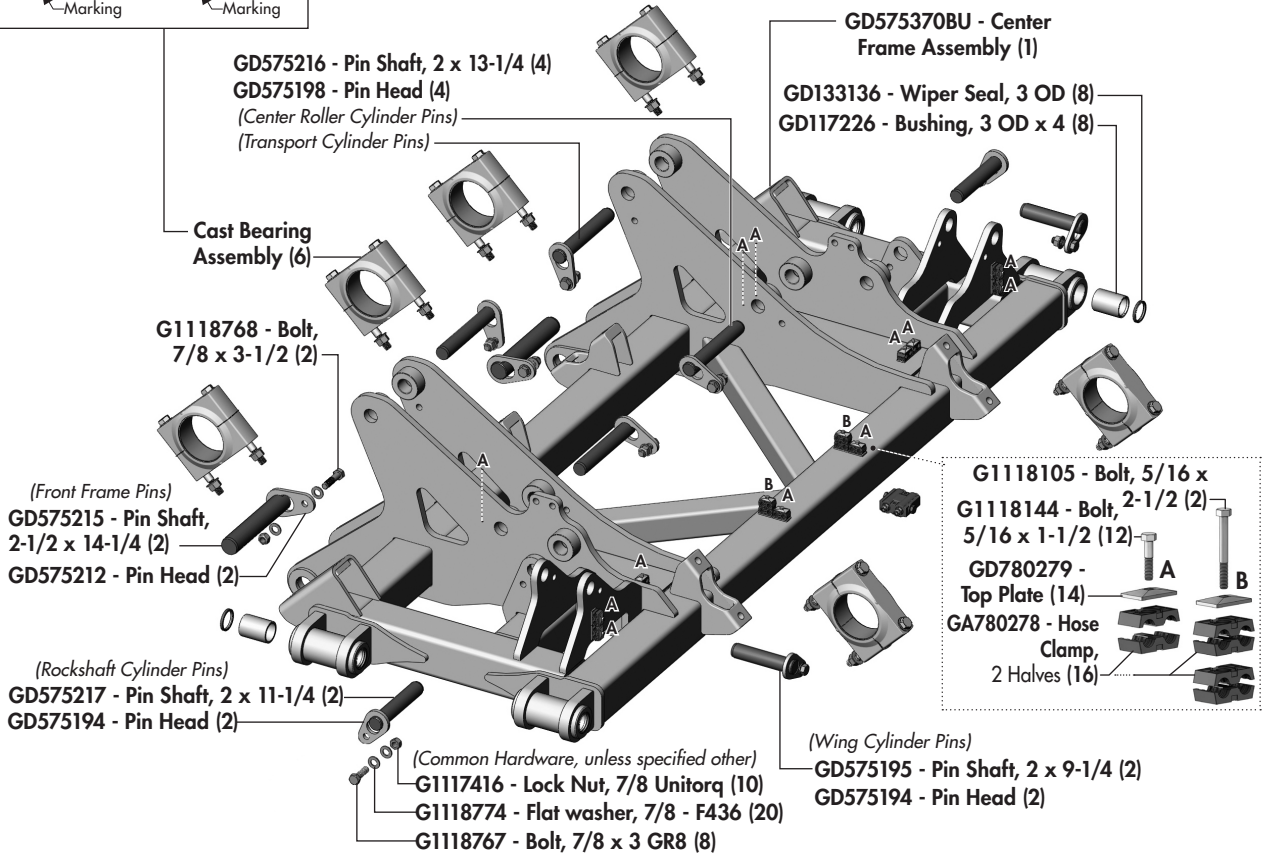
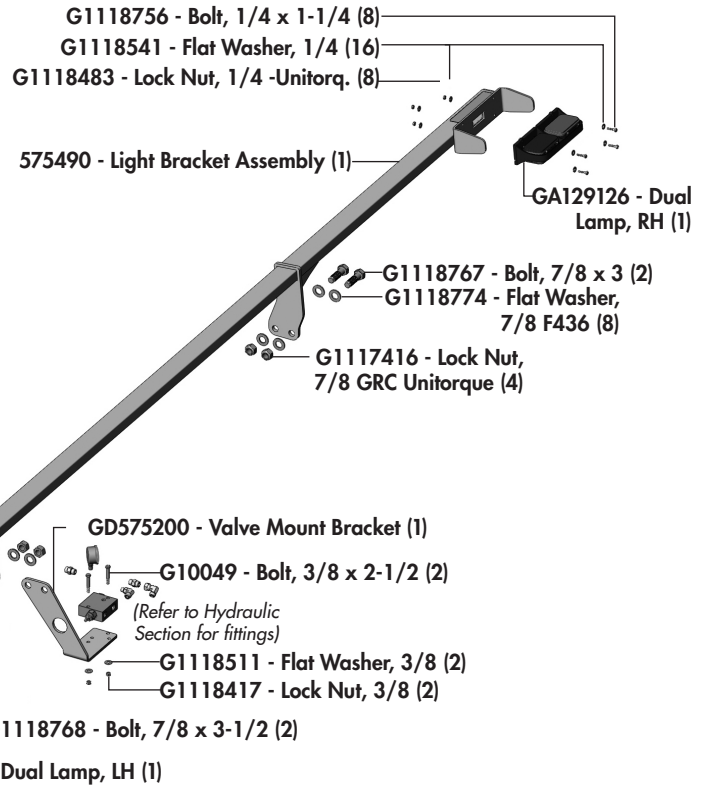
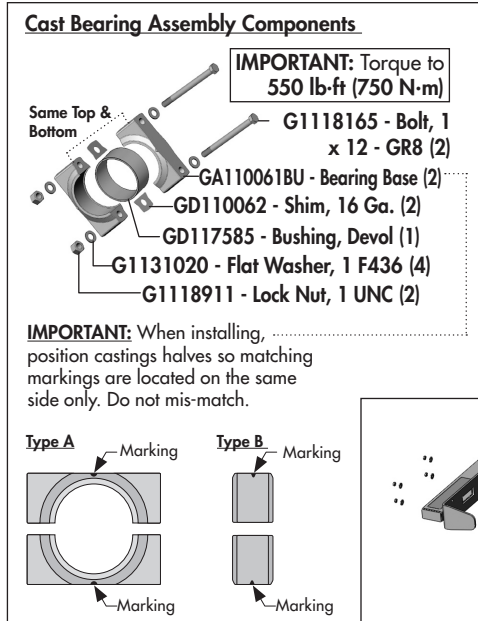

End Wheel Components

End Wheel Components for Mach Till 412 (RH Shown)

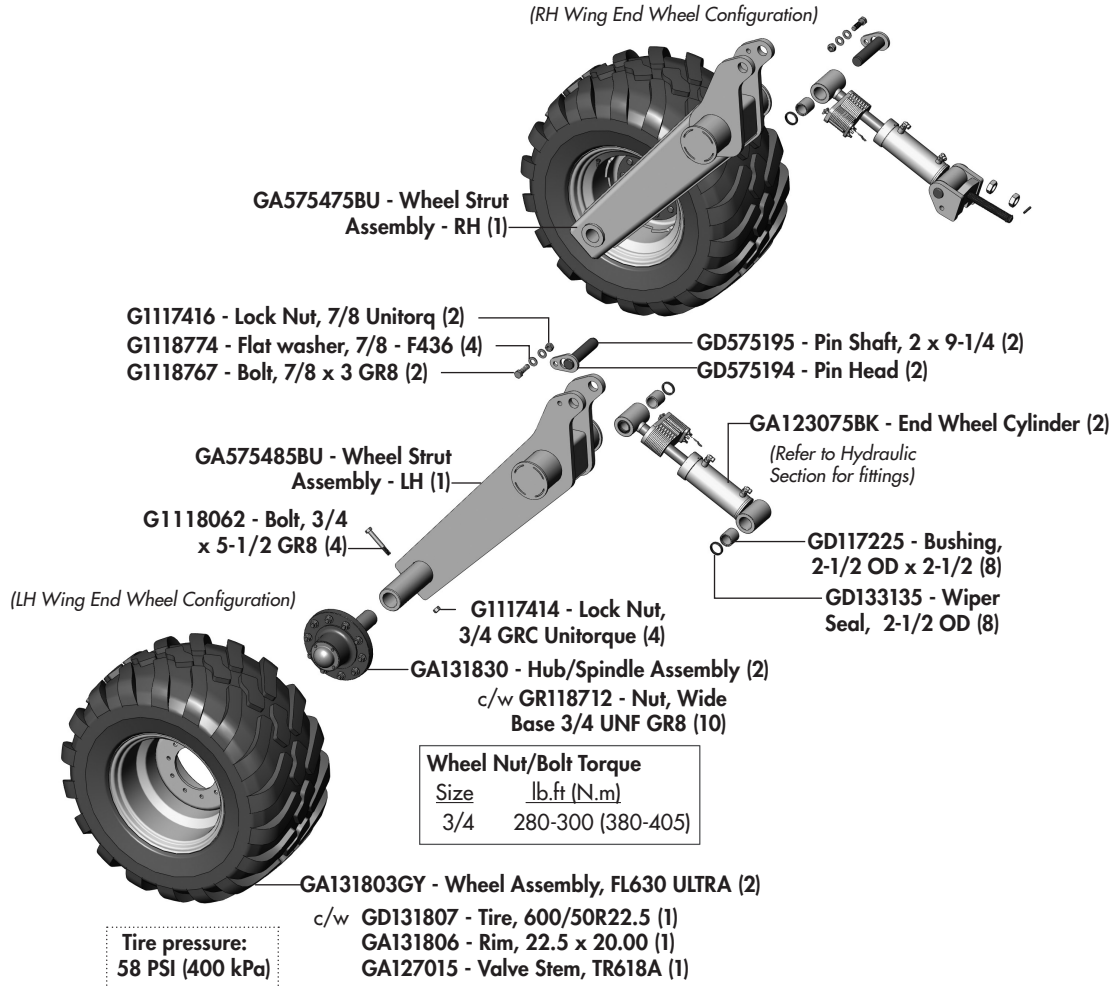

GA131830 - Hub/Spindle Assembly (4)

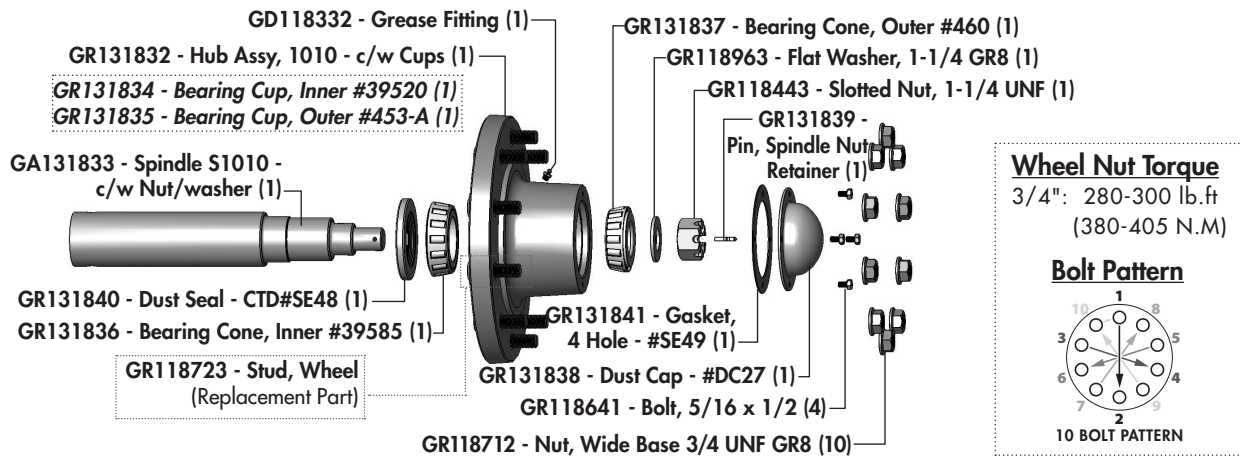

Wing Frame Components

Wing Frame Components for Mach Till 412 (LH Wing Shown)

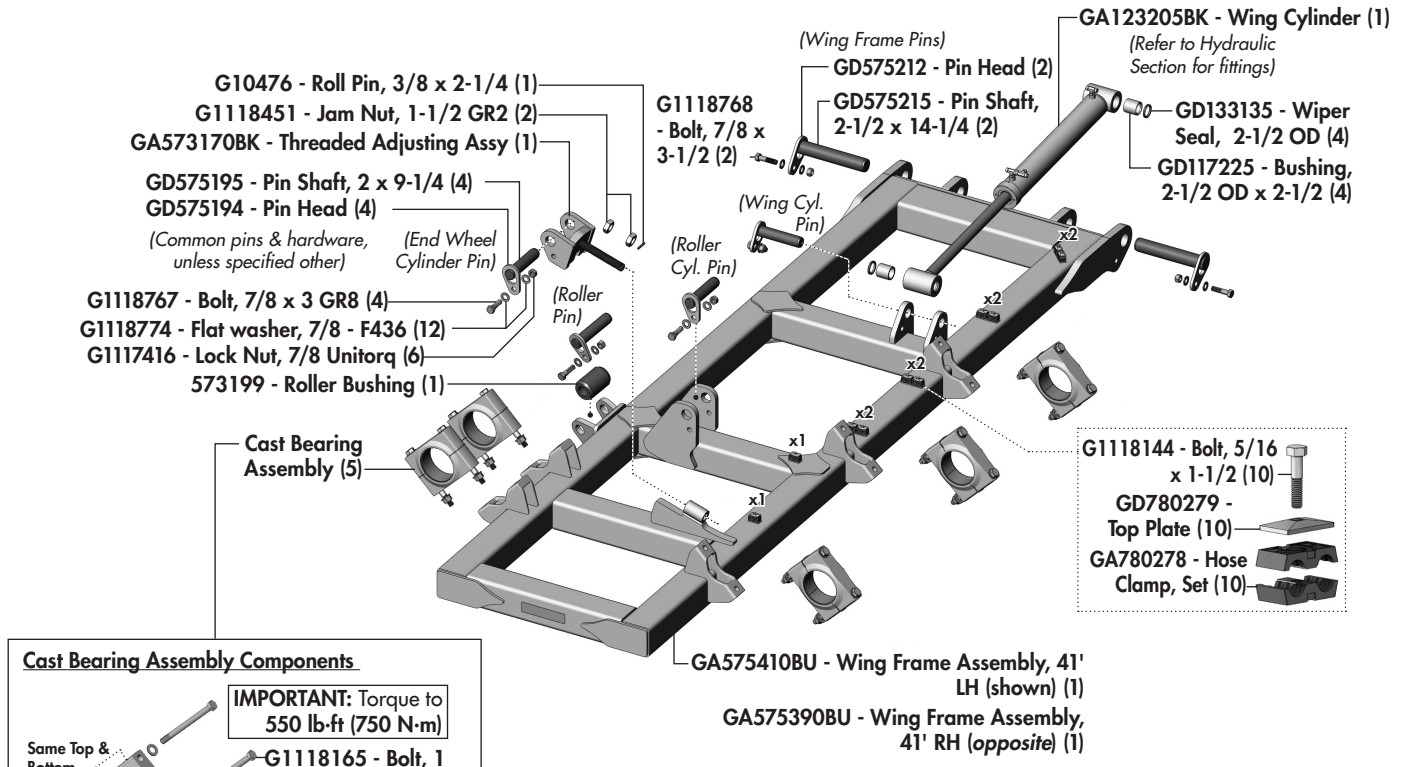

Cast Bearing Assembly Components

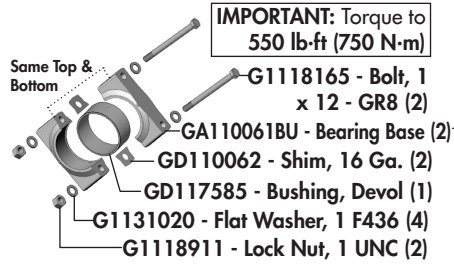

IMPORTANT: When installing, position castings halves so matching markings are located on the same side only. Do not mis-match.

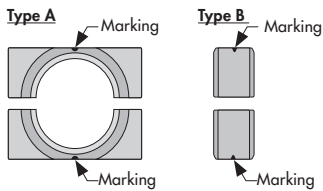

(Refer to above exploded component overview for required components)

(NOTE: There is only one Deflector required and it is located on the RH wing)

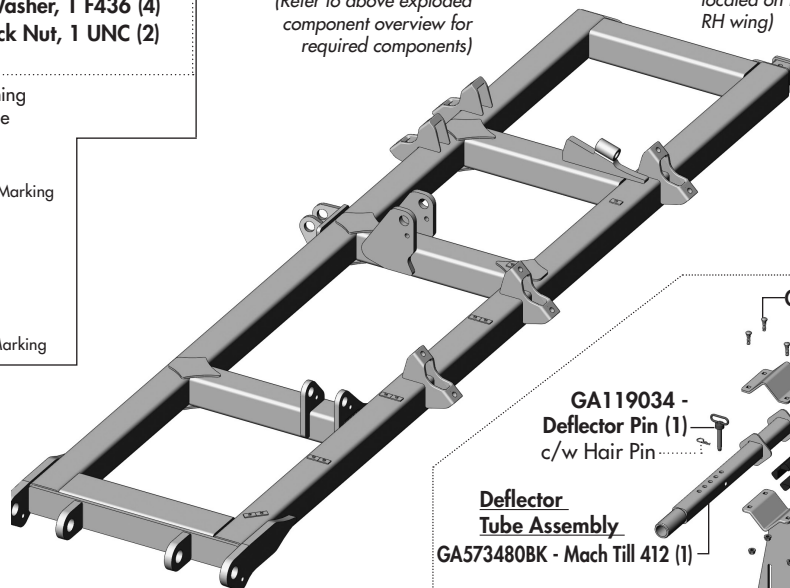

Disc Gang Components - Mach Till 412

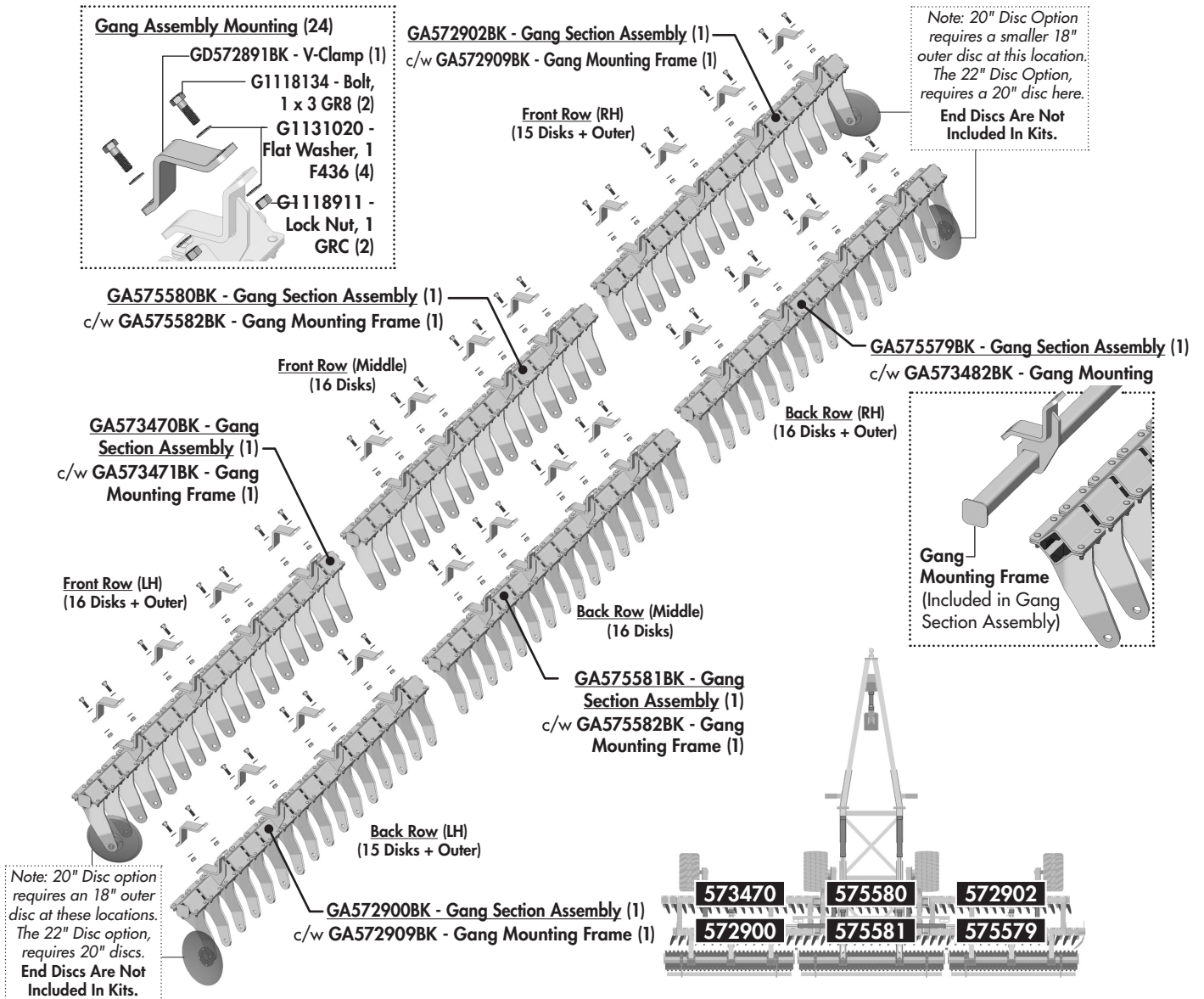

Setting Gang Section Spacing - Overview

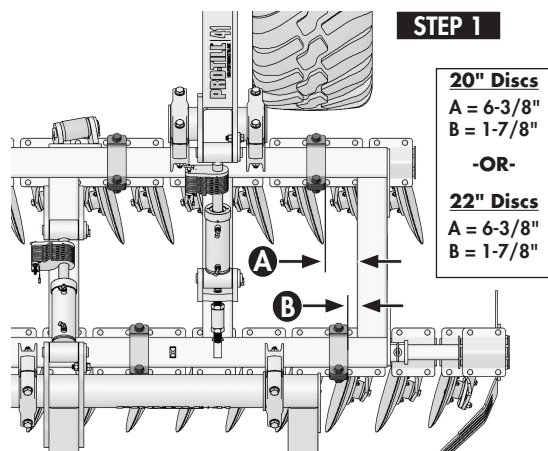

1. Gang section spacing starts by setting the distance from the inside RH Wing Frame to the edge of the first V-Clamp on front & rear gang sections. (Measurements - **A** & **B** in diagram).
2. Then, the distance between the *left* endcap of the first gang section and the *right* endcap of the next gang section should be set to 1-1/2". This should be the standard distance between all gang sections.

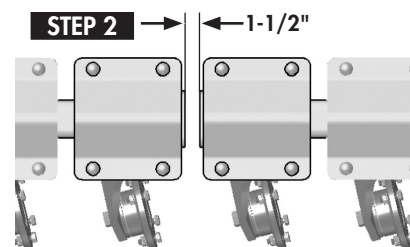

This page intentionally blank.

Disc Arm Components & Disc Options

Front Row - Standard Disc Assembly Components

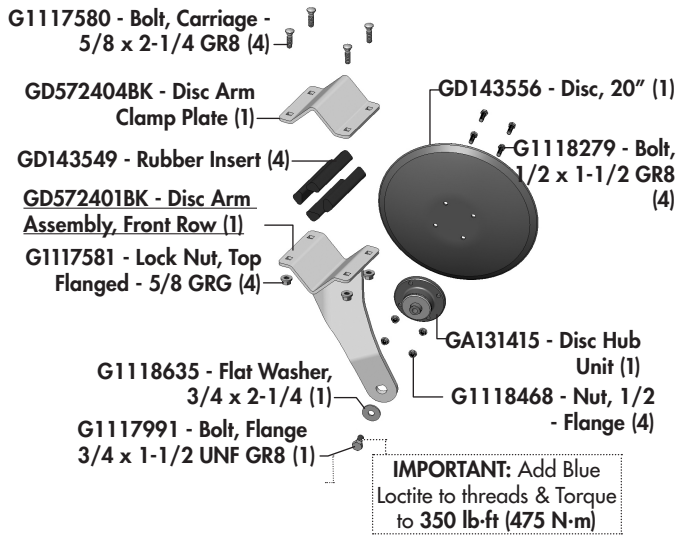

Back Row - Standard Disc Assembly Components

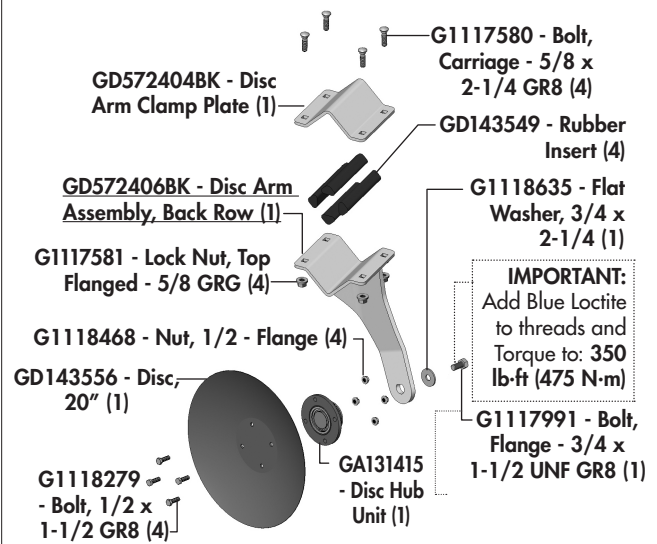

Disc Hub Components

GA131415 - Disc Hub Unit (Varied Suppliers) - Replacement O-Rings

SKF - Markings



GR121082 - O-Ring, Nitrile M5.3x87.5 (1)

Discs/Hubs - Required Numbers Per Machine

41' Mach Till Requires 98 Discs/Hubs

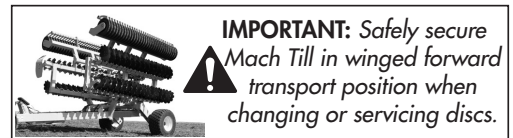

Standard	20"
Premium Discs	
20" Straight	20" Double-V Notched
GD143556	GD143553

Typical Factory Settings of End Discs

20" Disc Option

(4) - 18" End Discs - Straight **GD143550**

(Note: Customers may wish to adjust the end disc sizes and locations for customer preferred performance in certain soil or field conditions.)

Roller Frame Components

Roller Location Overview - 4m & 4.5m

Mach Till 412

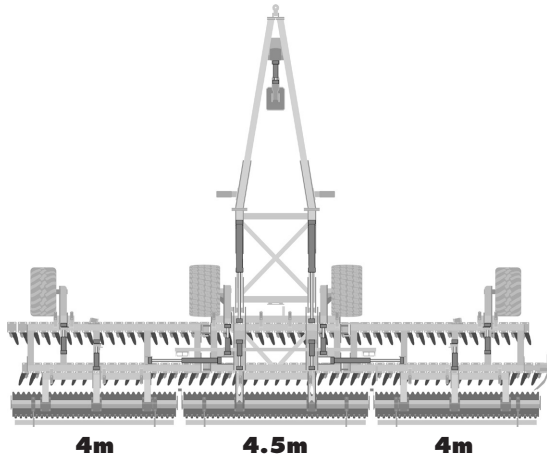

Mounting Frame to Roller Frame Dimensions

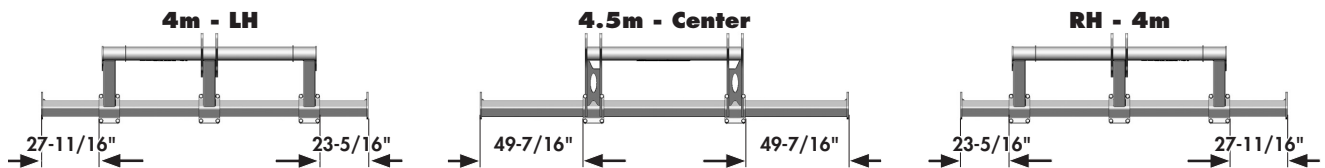

Ridge Wiper Components

Knocks down the possible ridge of dirt left from buildup in between the rollers.

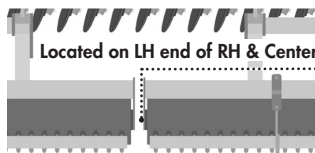

Initially set to highest setting as shown then adjust lower as necessary until desired results are achieved. **Note:** Setting too low can result in a trench or possibly cause plugging.

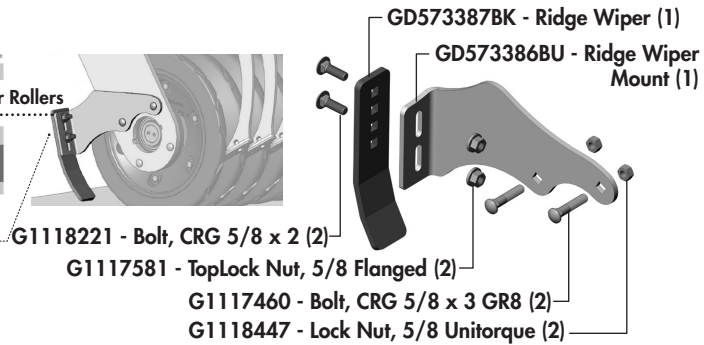

Roller Frame Components

Roller Mounting Frame Components

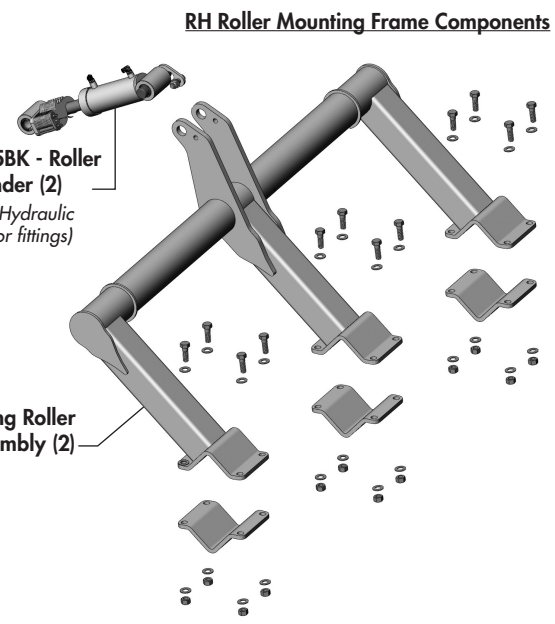
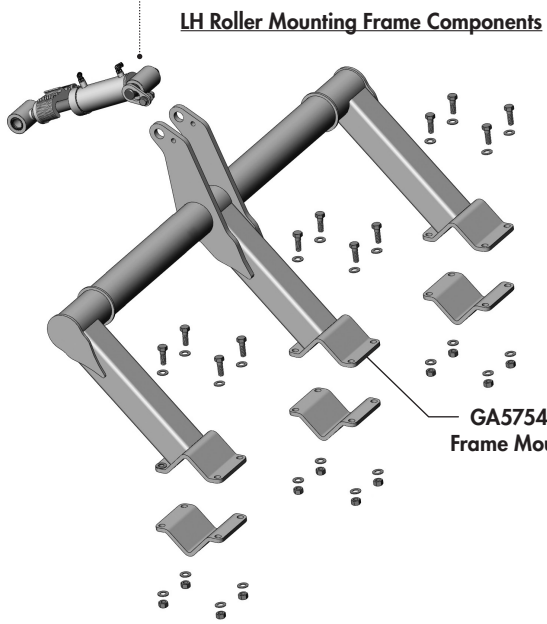
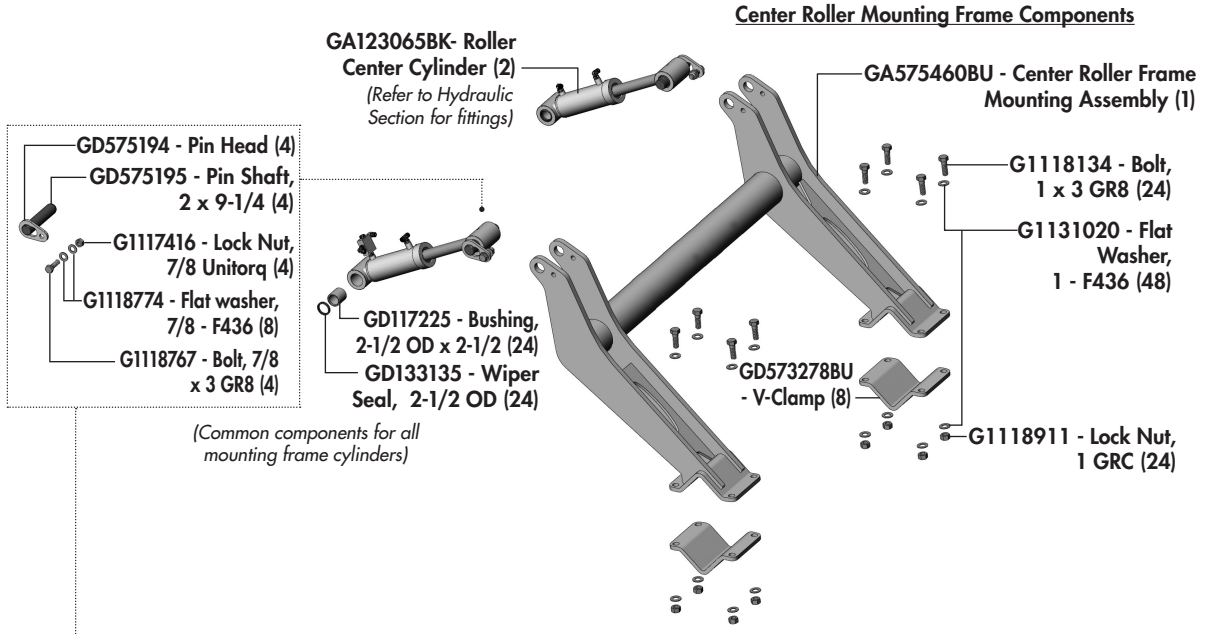

Roller Frame Components

Roller Options & Frame Components (4.5m)

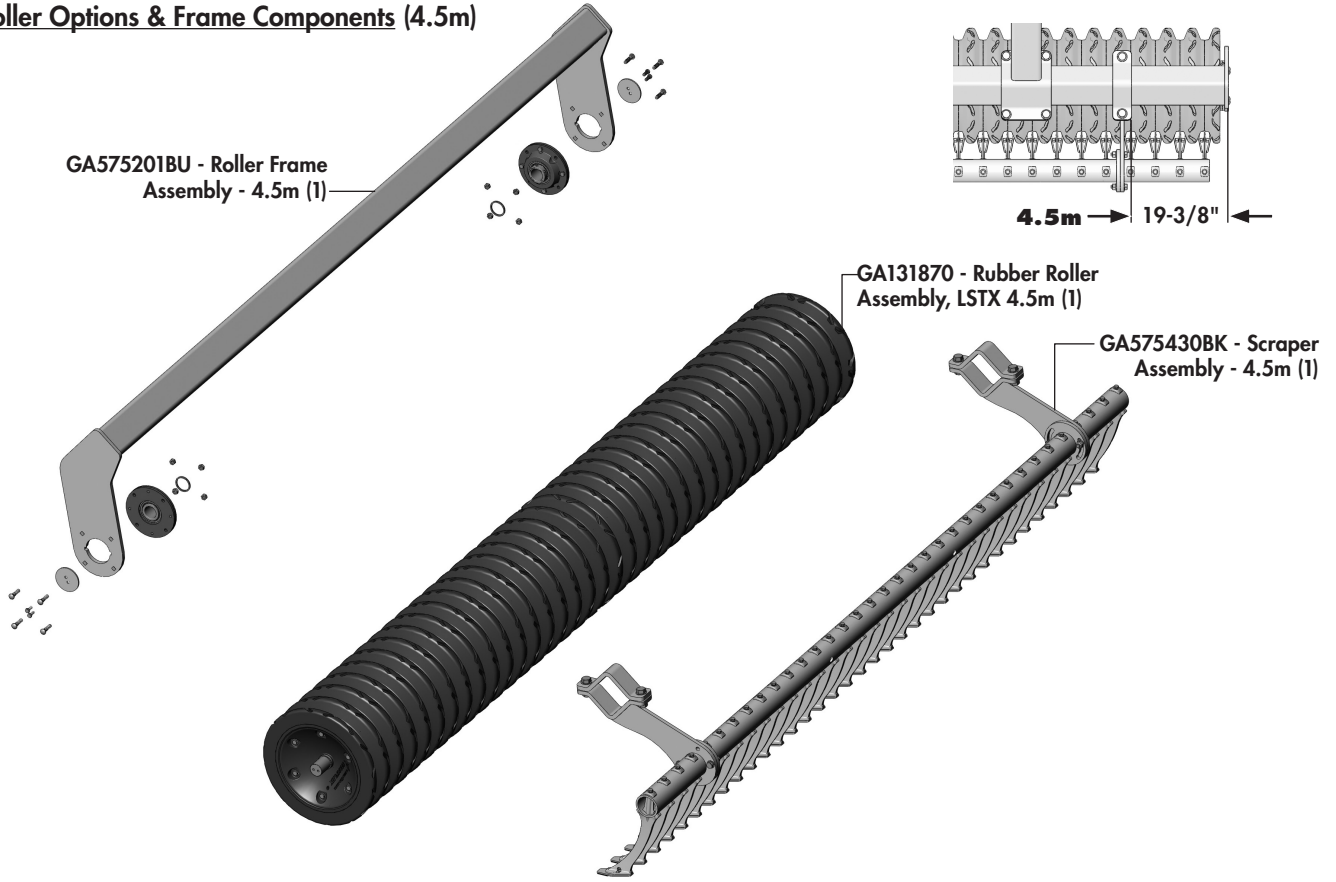

Roller Options & Frame Components (4m)

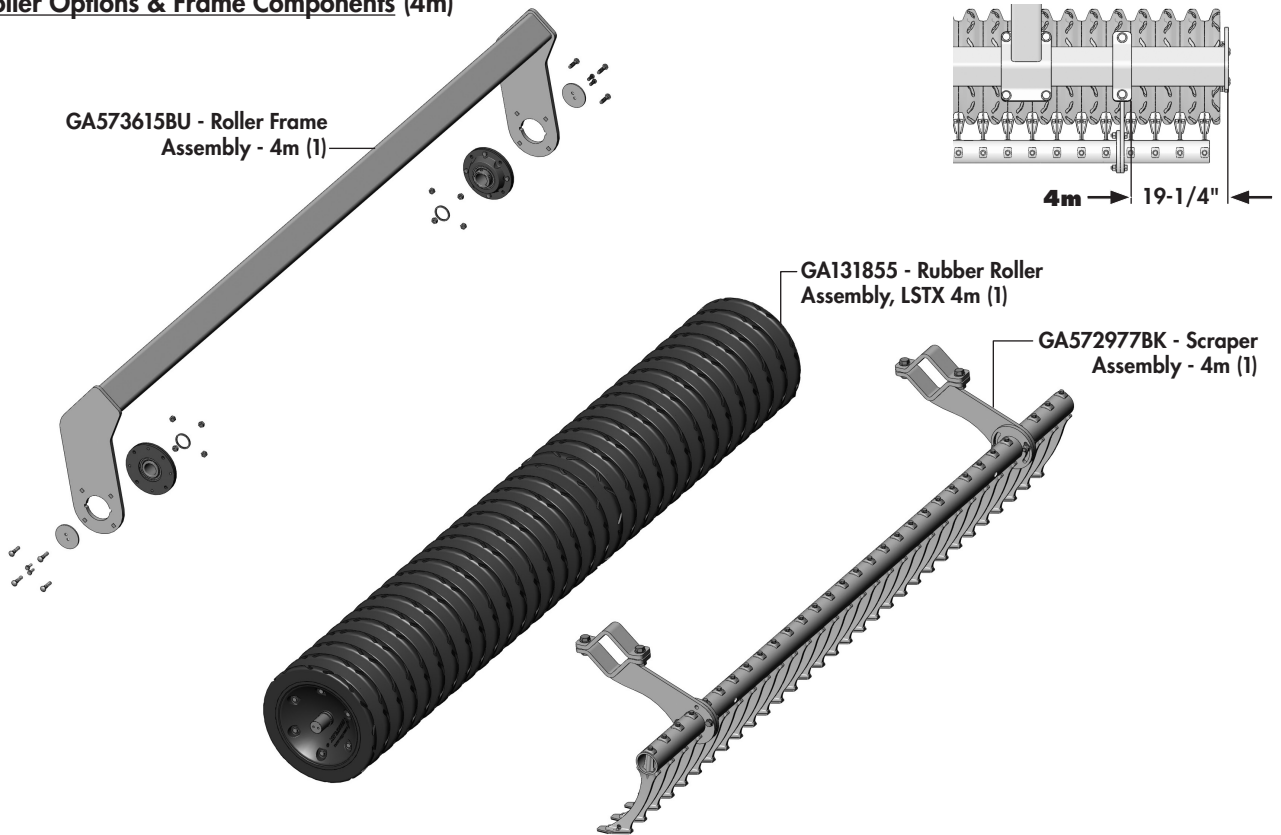

Roller Components

Roller Assembly Overview



Common Rubber Roller End Assembly Components

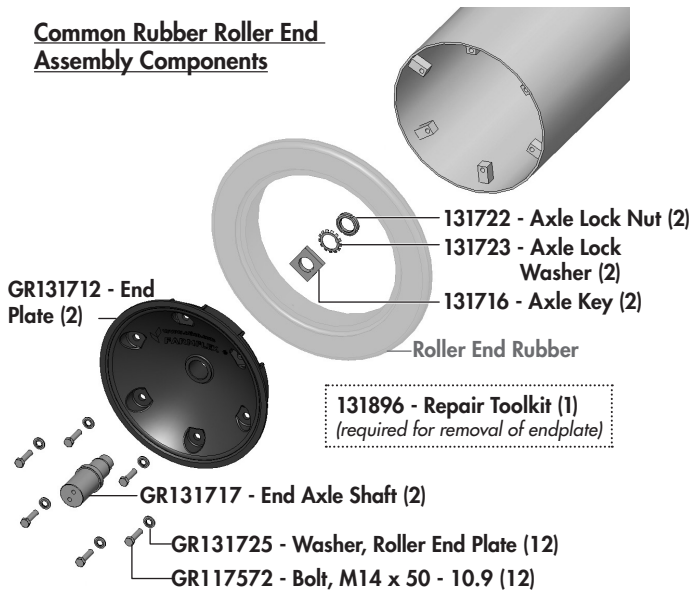

Roller Bearing Components

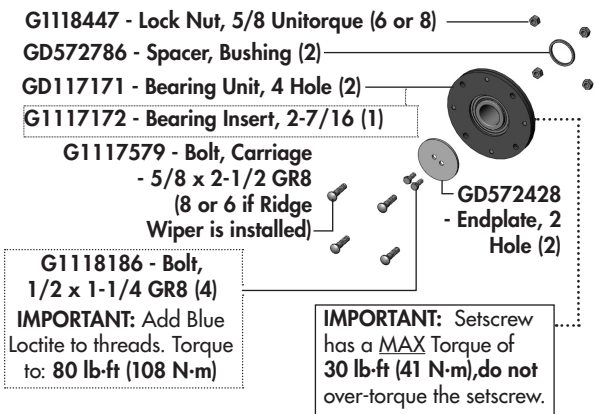

IMPORTANT: Add Blue Loctite to threads. Torque to: 80 lb-ft (108 N-m)

IMPORTANT: Setscrew has a MAX Torque of 30 lb-ft (41 N-m), do not over-torque the setscrew.

Scraper Components

Scraper Section Component Overview

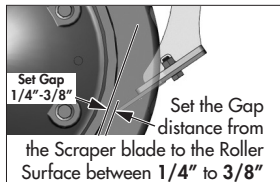
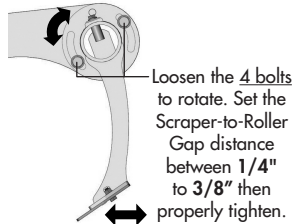
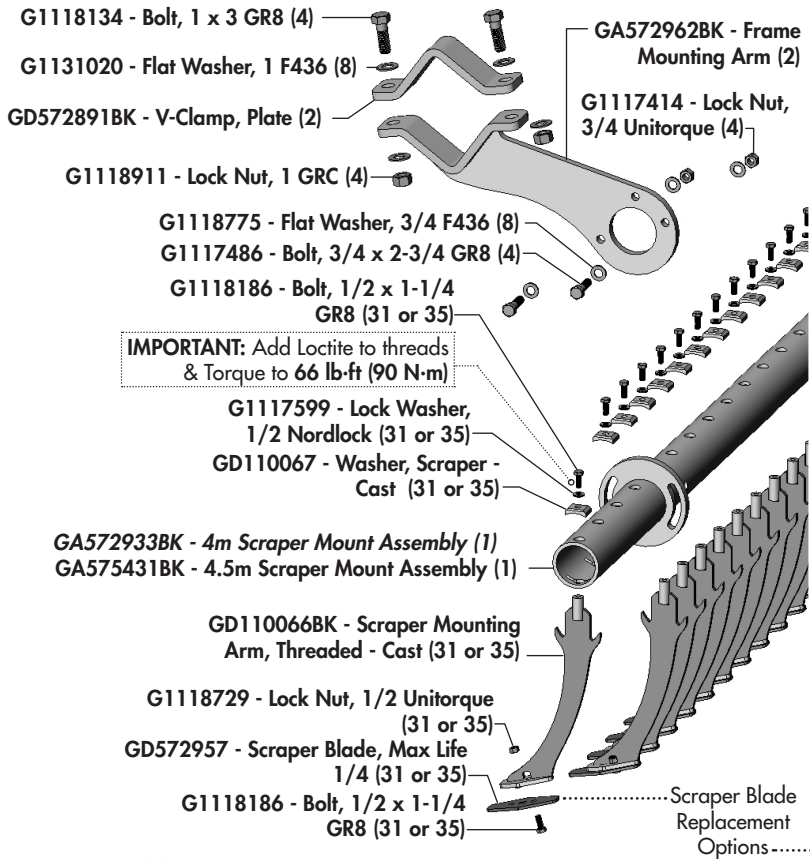

Max-Life Replacement Scraper Blades
 requires new hardware (Locknuts)
 Kits: 41': GA575296 (97)

GD572957 - Scraper Blade, Max-Life - 1/4
 G1118186 - Bolt, 1/2 x 1-1/4 GR8
 G1118729 - Lock Nut, 1/2 Uunitorque

Wear Edge down

Hydraulic Layout - 1 - Wheels

Hydraulic Fittings Required

- | | | | |
|----|--|---|-----|
| 1 | | GD141581 - Coupler Tip, 3/4 ORB F | (2) |
| 2 | | GD141676 - Connector, 3/4 ORB M x M | (2) |
| 3 | | GD141684BU - Coupler, Green (+) | (1) |
| 4 | | GD141685BU - Coupler, Green (-) | (1) |
| 5 | | GD141703 - Adaptor, 1/2 ORB M x ORFS M | (2) |
| 6 | | GA141704 - Elbow, 90° 1/2 ORB M x ORFS M | (7) |
| 7 | | GD141706 - Tee, 1/2 ORFS M | (2) |
| 8 | | GA141735 - Hydraulic Check Valve | (1) |
| 9 | | GD141679 - Nipple, 3/4 ORB m x 3/4 ORB m-adj | (1) |
| 10 | | GD141707 - Tee, 1/2 ORFS M x M x 1/2 ORB M-adj | (1) |
| 11 | | GA141711 - 90° Elbow, 1/2 ORFS M x 9/16 ORB M (1) | |
| 12 | | GA126755 - Hose, 1/2 x 8 - 1/2 ORFS F-SW-1 EL (1) | |

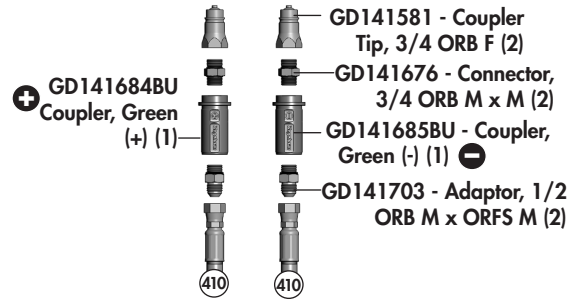

Required Hoses for Wheel Cylinders

- | | | |
|--|----------------------------|-----|
| | *A126835 - Hose, 3/8 x 30 | (1) |
| | *A126863 - Hose, 3/8 x 96 | (1) |
| | *A126849 - Hose, 3/8 x 410 | (2) |
| | *A126860 - Hose, 3/8 x 250 | (1) |
| | *A126841 - Hose, 3/8 x 205 | (2) |
| | *A126840 - Hose, 3/8 x 188 | (1) |

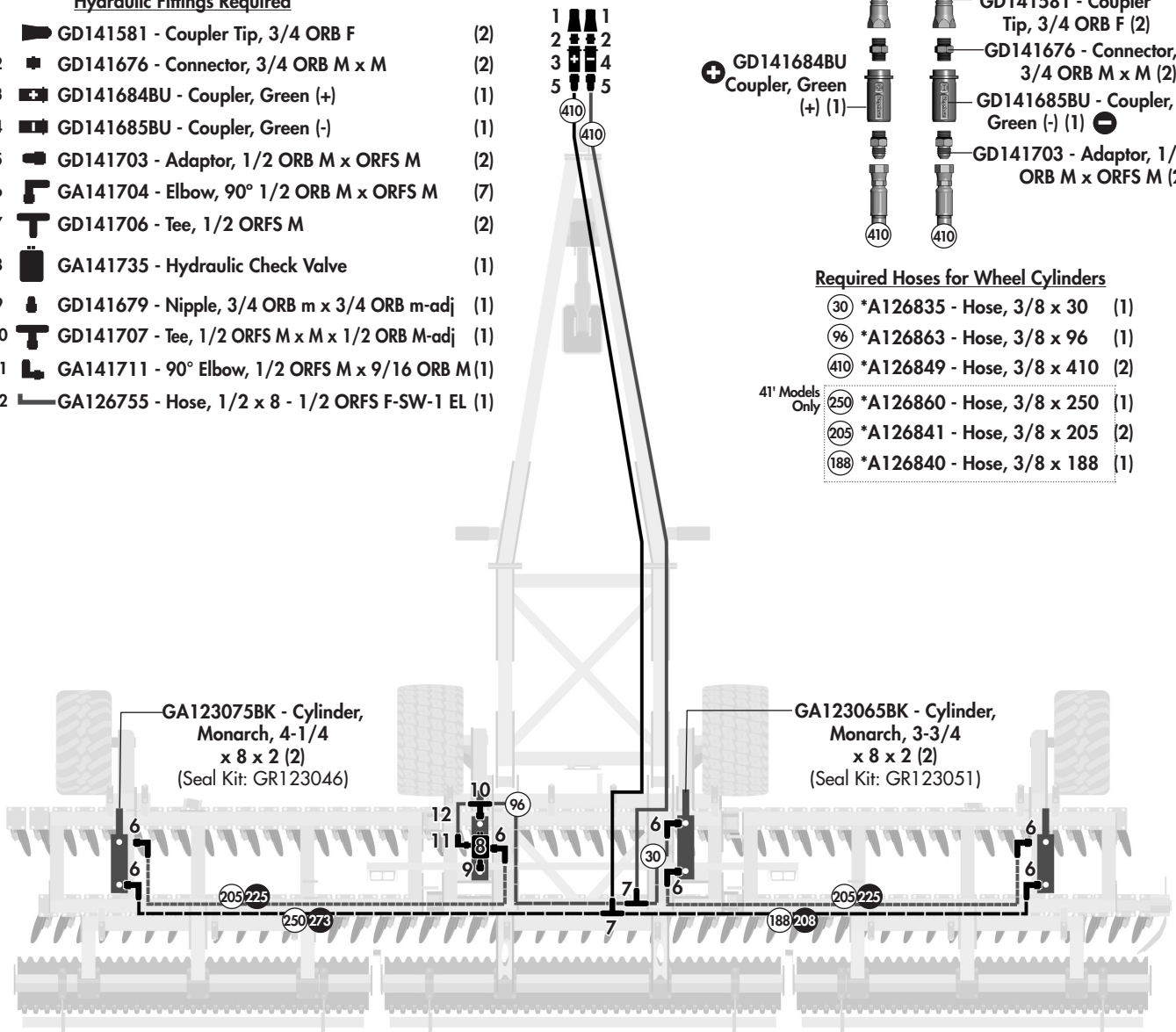

Detail A - LH Center Frame Wheel Cylinder Valve Overview

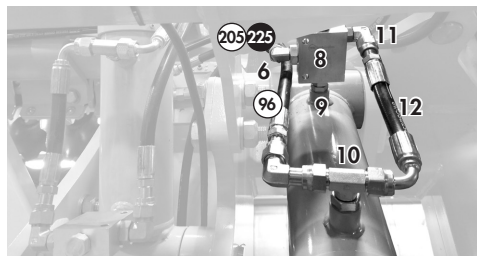

Detail B - RH Wing Wheel Cylinder Overview

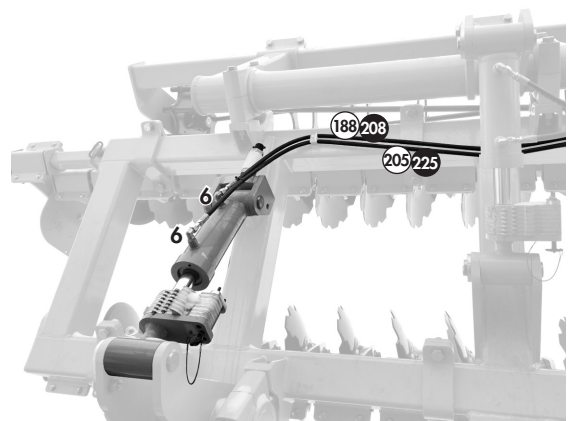

* Hydraulic hose is not stocked by Kinze Repair Parts.

Hydraulic Layout - 2 - Rollers

Hydraulic Fittings Required

- | | | | |
|----|--|--|-----|
| 1 | | GD141581 - Coupler Tip, 3/4 ORB F | (2) |
| 2 | | GD141676 - Connector, 3/4 ORB M x M | (2) |
| 3 | | GD141682BU - Coupler, Blue (+) | (1) |
| 4 | | GD141683BU - Coupler, Blue (-) | (1) |
| 5 | | GD141703 - Adaptor, 1/2 ORB M x ORFS M | (4) |
| 6 | | GA141704 - Elbow, 90° 1/2 ORB M x ORFS M | (9) |
| 7 | | GD141706 - Tee, 1/2 ORFS M | (2) |
| 8 | | GA141735 - Hydraulic Check Valve | (1) |
| 9 | | GD141679 - Nipple, 3/4 ORB m x 3/4 ORB m-adj | (1) |
| 10 | | GD141707 - Tee, 1/2 ORFS M x M x 1/2 ORB M-adj | (1) |
| 11 | | GA141711 - 90° Elbow, 1/2 ORFS M x 9/16 ORB M | (1) |
| 12 | | GA126755 - Hose, 1/2 x 8 - 1/2 ORFS F-SW-1 EL | (1) |

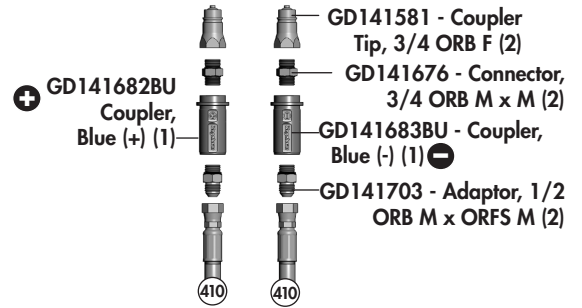

Required Hoses for Roller Cylinders

- | | |
|-----------------------|-------------------------------|
| (86) | *A126844 - Hose, 3/8 x 86(1) |
| (26) | *A126833 - Hose, 3/8 x 26(1) |
| (410) | *A126849 - Hose, 3/8 x 410(2) |
| 41' Models Only (233) | *A126842 - Hose, 3/8 x 233(1) |
| (180) | *A126839 - Hose, 3/8 x 180(2) |
| (164) | *A126838 - Hose, 3/8 x 164(1) |

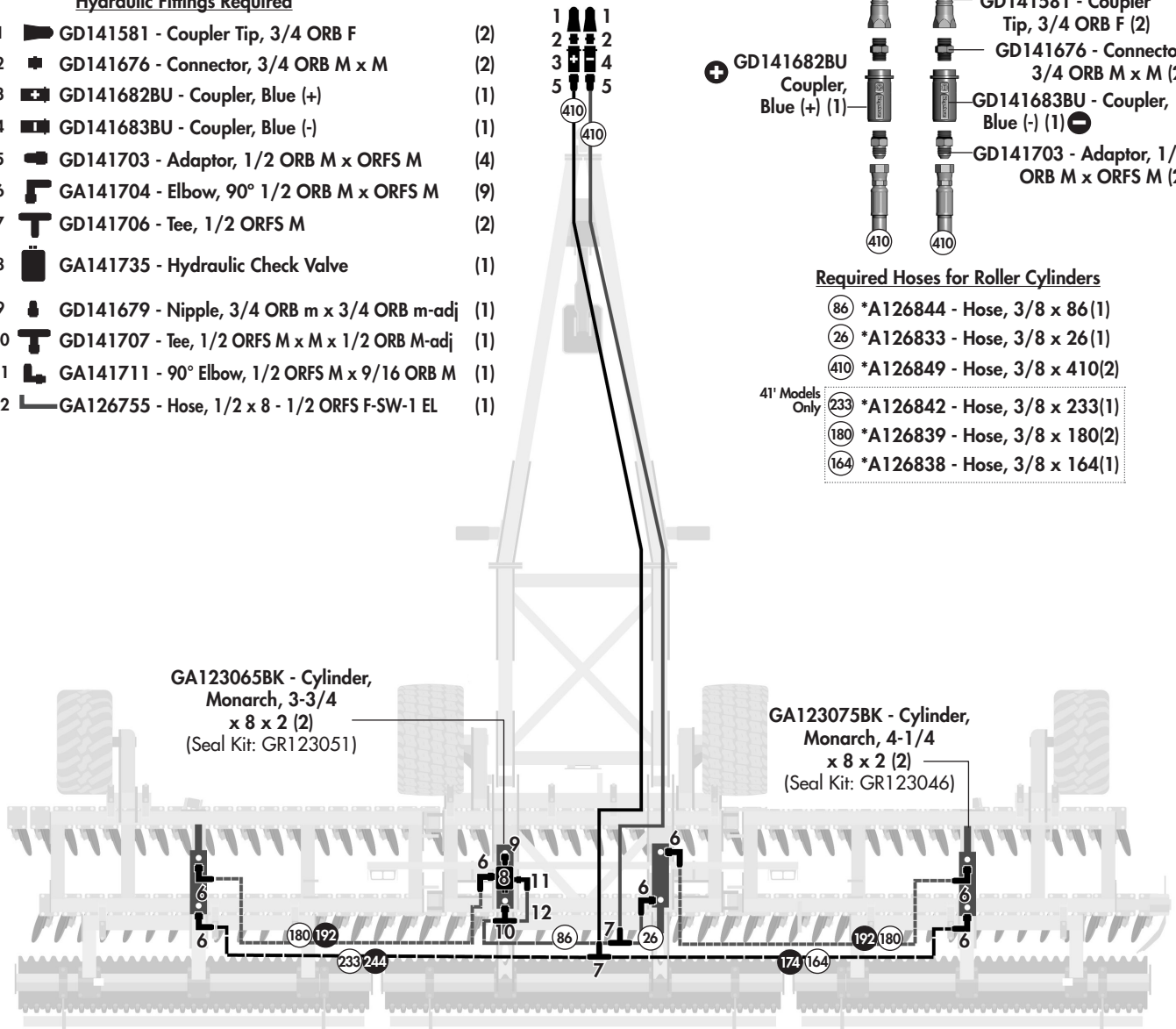

Detail A - LH Center Frame Roller Cylinder Valve Overview

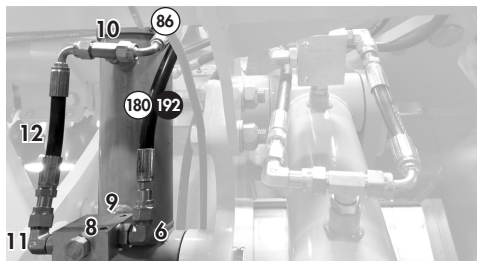

Detail B - RH Wing Roller Cylinder Overview

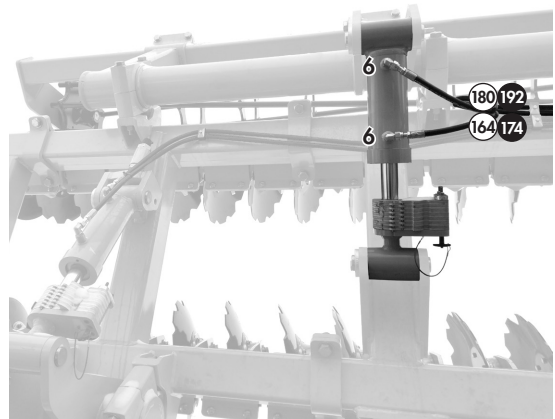

* Hydraulic hose is not stocked by Kinze Repair Parts.

Hydraulic Layout - 3 - Transport

Hydraulic Fittings Required

- 1 GD141581 - Coupler Tip, 3/4 ORB F (2)
- 2 GD141676 - Connector, 3/4 ORB M x M (2)
- 3 GD141686BU - Coupler, Brown (+) (1)
- 4 GD141687BU - Coupler, Brown (-) (1)
- 5 GD141703 - Adaptor, 1/2 ORB M x ORFS M (4)
- 6 GA141704 - Elbow, 90° 1/2 ORB M x ORFS M (9)
- 7 GD141707 - Tee, 1/2 ORFS M x M x 1/2 ORB M-adj (1)

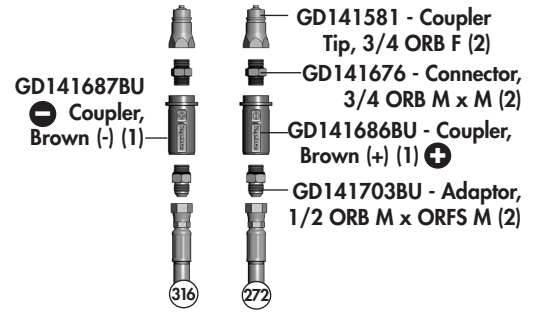

Required Hoses for Transport Cylinders

- 316 *A126848 - Hose, 3/8 x 316(1)
- 272 *A126847 - Hose, 3/8 x 272(1)
- 192 *A126846 - Hose, 3/8 x 192(1)
- 104 *A126861 - Hose, 3/8 x 104(1)

* Hydraulic hose is not stocked by Kinze Repair Parts.

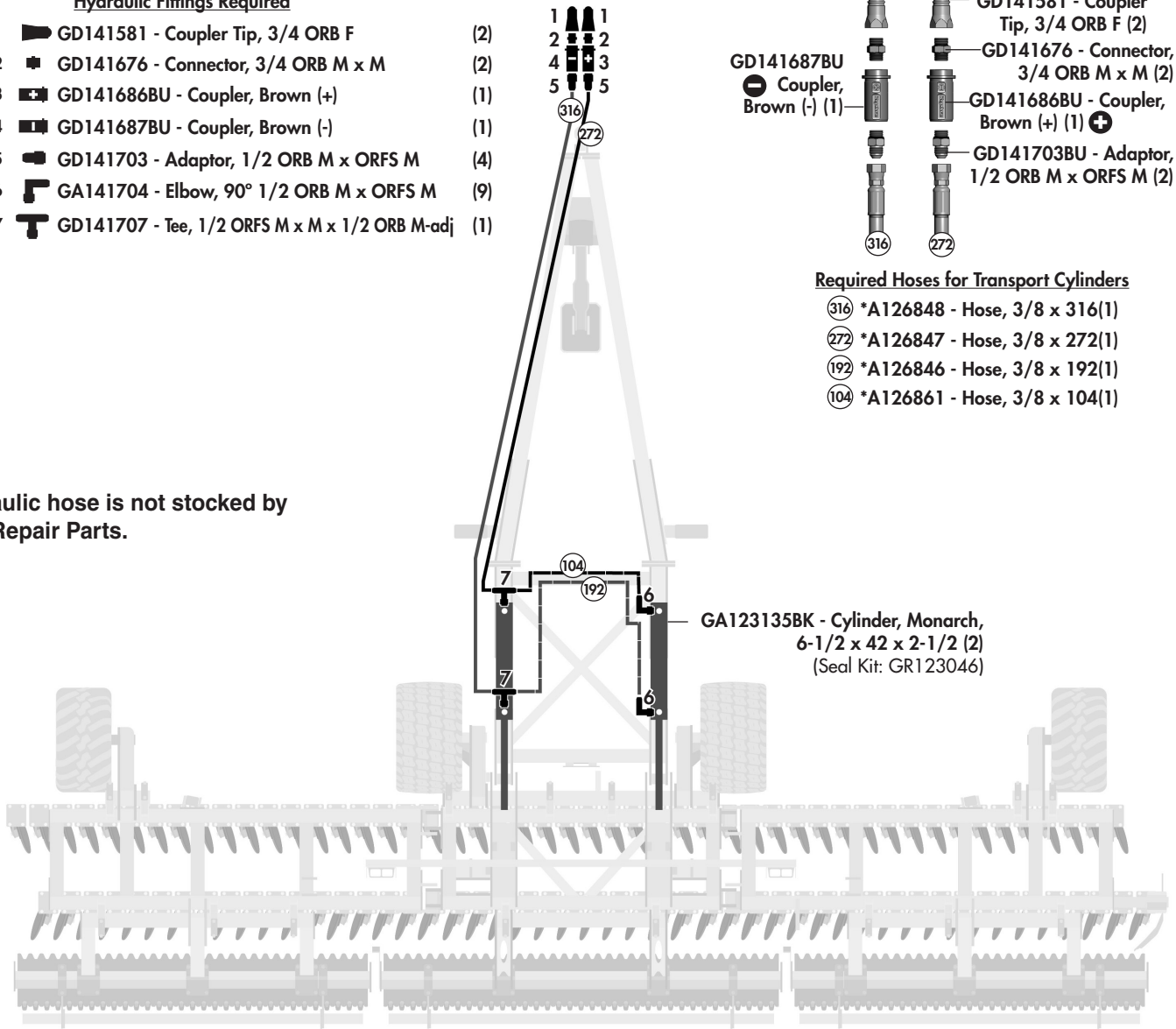

Detail A - Transport Cylinders General Overview

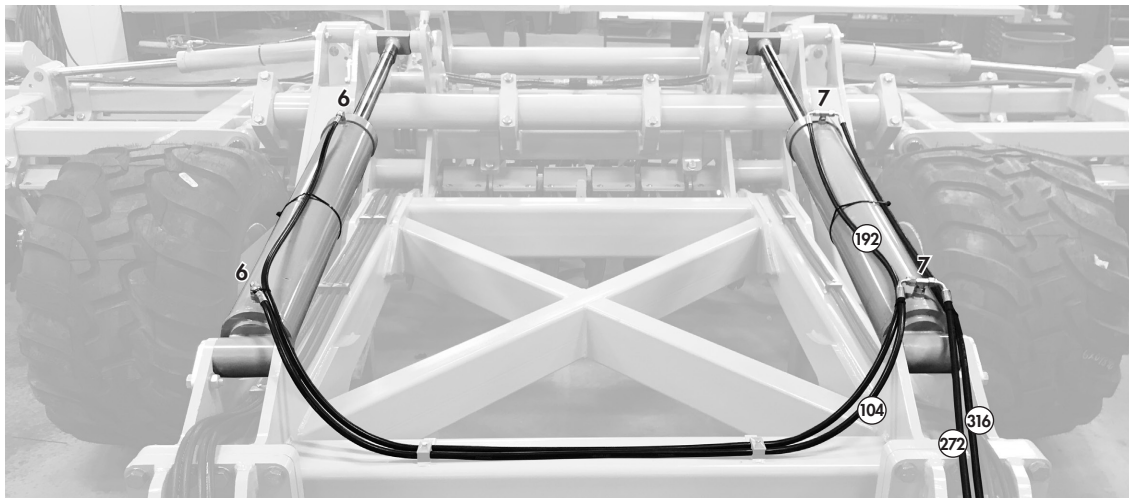

Hydraulic Layout - 4 - Wings

Hydraulic Fittings Required

- | | | |
|----|--|-----|
| 1 | GD141581 - Coupler Tip, 3/4 ORB F | (2) |
| 2 | GD141676 - Connector, 3/4 ORB M x M | (2) |
| 3 | GD141688BU - Coupler, Black (+) | (1) |
| 4 | GD141689BU - Coupler, Black (-) | (1) |
| 5 | GD141703 - Adaptor, 1/2 ORB M x ORFS M | (8) |
| 6 | GA141704 - Elbow, 90° 1/2 ORB M x ORFS M | (2) |
| 7 | GD141707 - Tee, 1/2 ORFS M x M x 1/2 ORB M-adj | (2) |
| 8 | GA141740 - Valve, Reducing Relieving | (1) |
| 9 | GA27098 - Pressure Gauge | (1) |
| 10 | GD141727 - Tee, 1/2 ORFS M x F-SW x M | (1) |
| 11 | GA141711 - 90° Elbow, 1/2 ORFS M x 9/16 ORB M | (1) |
| 12 | GD141715 - 90° Elbow, 1/2 ORFS M x F-SW | (1) |
| 13 | GA141524 - Relief Valve, 2000 PSI - 3/4 ORB | (1) |
| 14 | GD122668 - Orifice, 3/4-16 UNF | (2) |

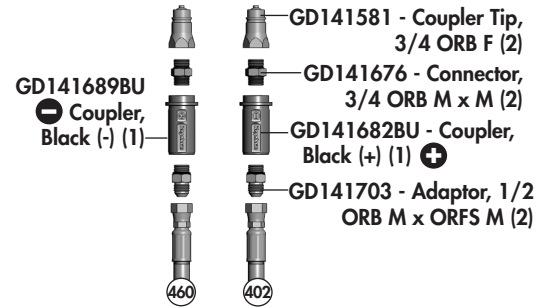

Required Hoses for Wing Cylinders

- | | | |
|-----|----------------------------|-----|
| 460 | *A126834 - Hose, 3/8 x 460 | (1) |
| 402 | *A242978 - Hose, 3/8 x 402 | (1) |
| 86 | *A126844 - Hose, 3/8 x 86 | (2) |
| 58 | *A126843 - Hose, 3/8 x 58 | (2) |
| 54 | *A240905 - Hose, 3/8 x 54 | (1) |
| 28 | *A126862 - Hose, 3/8 x 28 | (1) |

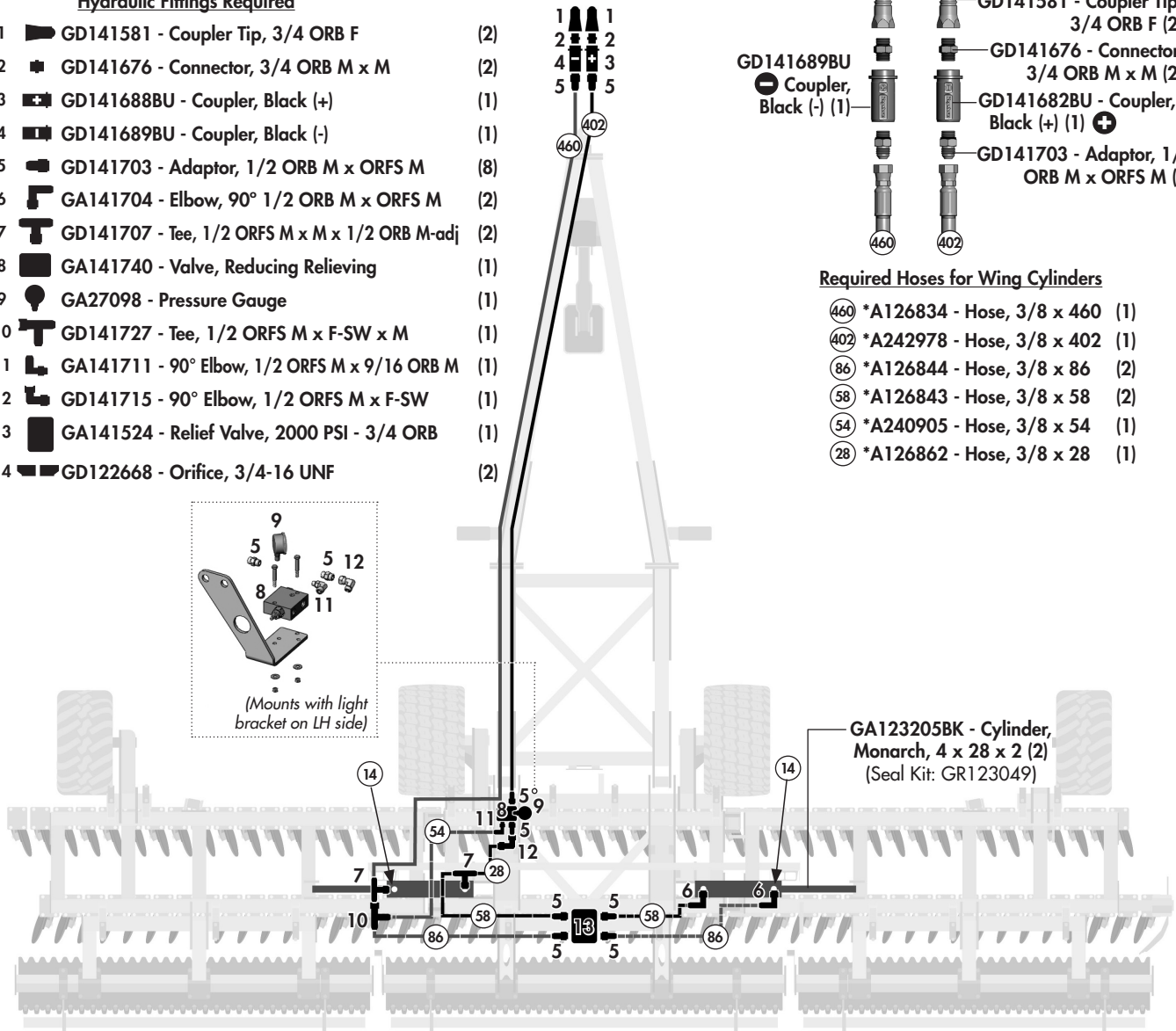





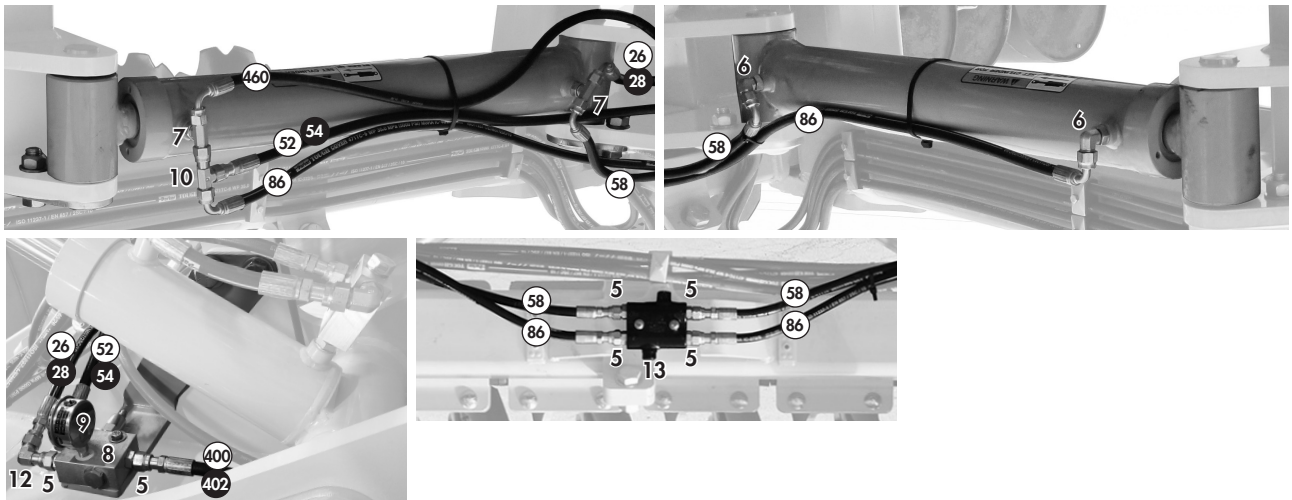



* Hydraulic hose is not stocked by Kinze Repair Parts.

Detail A - Transport Cylinders General Overview



Hydraulic Layout - 5 - Jack

Hydraulic Fittings Required

- | | | | |
|---|---|---|-----|
| 1 |  | GD141581 - Coupler Tip, 3/4 ORB F | (2) |
| 2 |  | GD141676 - Connector, 3/4 ORB M x M | (2) |
| 3 |  | GD141680BU - Coupler, Grey (+) | (1) |
| 4 |  | GD141681BU - Coupler, Grey (-) | (1) |
| 5 |  | GD141703 - Adaptor, 1/2 ORB M x ORFS M | (4) |
| 6 |  | GA141704 - Elbow, 90° 1/2 ORB M x ORFS M | (1) |
| 7 |  | GA141705 - Elbow, 90° 1/2 ORB M x ORFS F-SW | (1) |
| 8 |  | GD122668 - Orifice, 3/4-16 UNF | (1) |
| 9 |  | GA141597 - Ball Valve - 3/4 ORB F | (1) |

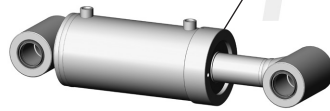
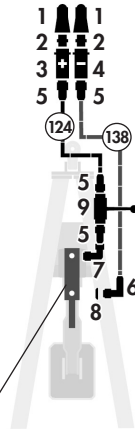

GA123148BK - Cylinder,
5-1/2 x 8 x 2-1/2 (1)
(Seal Kit: GR123047)

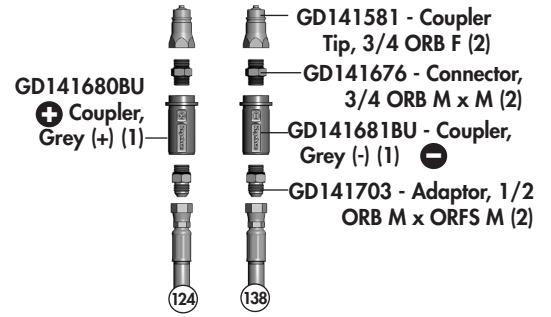

Required Hoses for Jack Cylinder

- | | | |
|-----|----------------------------|-----|
| 138 | *A126837 - Hose, 3/8 x 138 | (1) |
| 124 | *A126845 - Hose, 3/8 x 124 | (1) |

Jack / Ball Valve Connection Detail

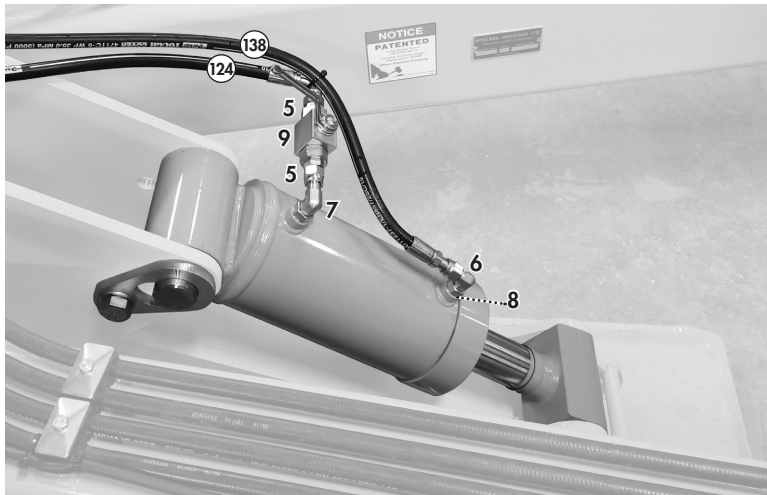

▲ IMPORTANT:

Close the ball valve to prevent accidental operation of this circuit. Ensure ball valve handle remains in closed position.

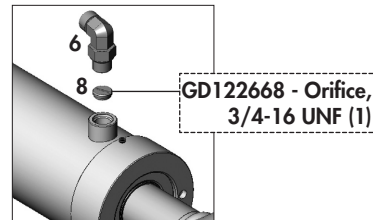
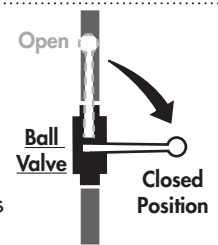

* Hydraulic hose is not stocked by Kinze Repair Parts.

Cylinders & Depth Stop Components

RH ARRANGEMENT OF DEPTH STOPS

(Note: The factory height setting of the threaded bushing-bolt plate bushing distance is set by using the stack of depth plates and a gap clearance of less than 1/32")

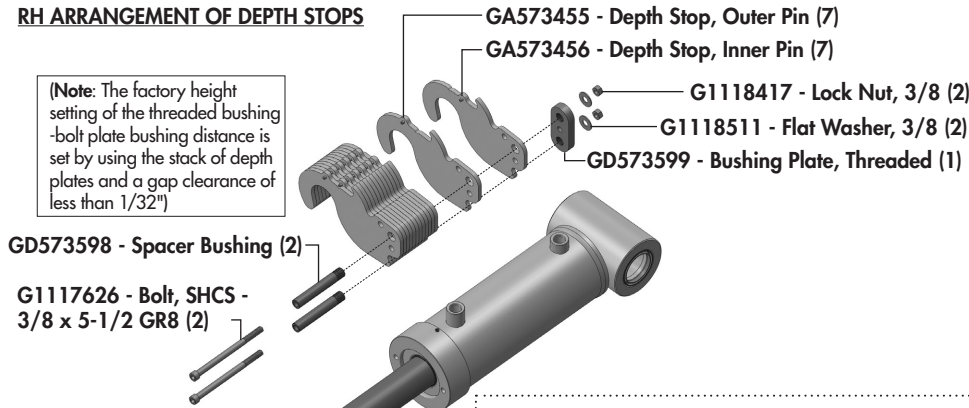

LH ARRANGEMENT OF DEPTH STOPS

GA573458 - Depth Stop, Inner Pin (7)
GA573457 - Depth Stop, Outer Pin (7)

GA117589 - Pin, Self-Lock - 3/8 x 5 (1)
mounts with:
G1117248 - Screw, #6-20 x 3/8 (1)

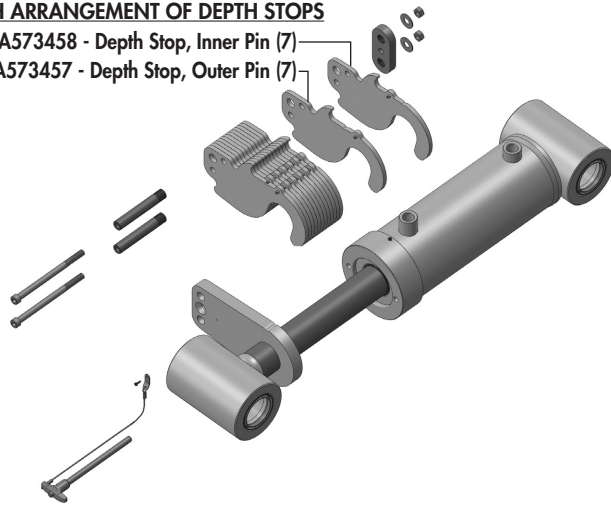

GA123075BK - Cylinder, Monarch - 4-1/4 x 8 x 2 (4)

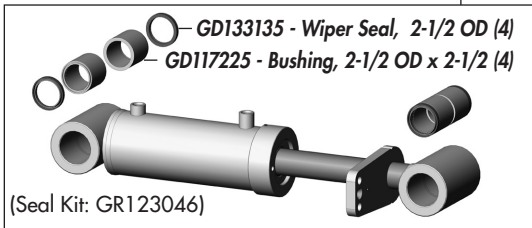

Maintenance Free Pins & Bushings

⚠ IMPORTANT: INSTALL DRY
Do NOT use any oil/grease/lubricant on pin or bushing surfaces when installing the maintenance free pins into composite bushings.



GA123065BK - Cylinder, Monarch - 3-3/4 x 8 x 2 (4)

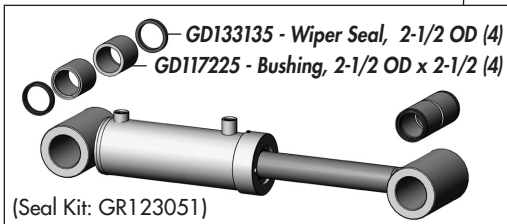

GA123135BK - Cylinder, Monarch - 6-1/2 x 42 x 2-1/2 (2)

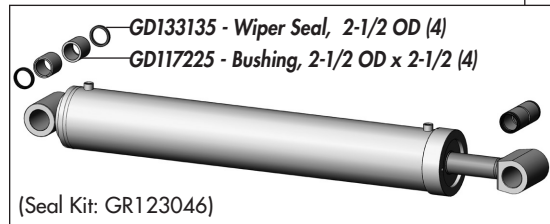

GA123148BK - Cylinder, Monarch - 5-1/2 x 8 x 2-1/2 (1)

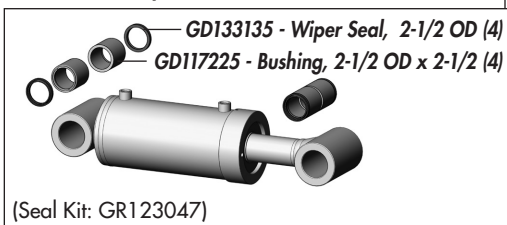

GA123205BK - Cylinder, Monarch - 4 x 28 x 2 (2)

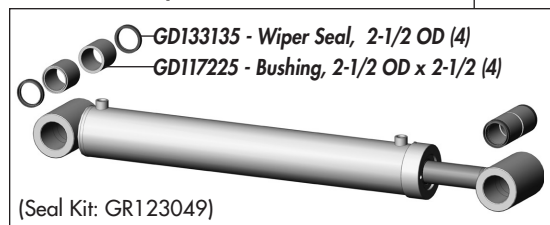

Light Routing - Standard

Wire Routing Overview

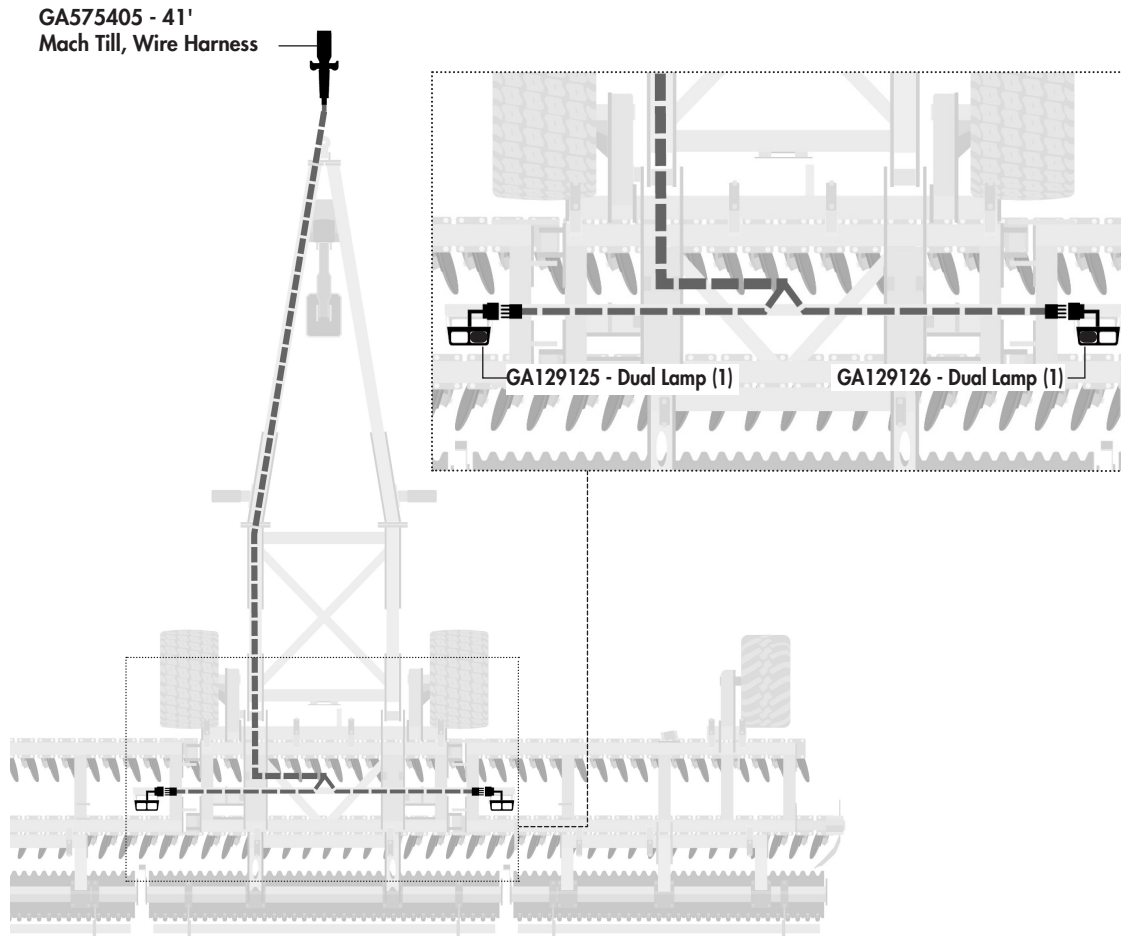

Warranty

The Kinze Limited Warranty for your new machine is stated on the retail purchaser's copy of the Warranty And Delivery Receipt form. Additional copies of the Limited Warranty can be obtained through your Kinze Dealer.

Warranty, within the warranty period, is provided as part of Kinze's support program for registered Kinze products which have been operated and maintained as described in this manual. Evidence of equipment abuse or modification beyond original factory specifications will void the warranty. Normal maintenance, service and repair is not covered by Kinze warranty.

To register your Kinze product for warranty, a Warranty And Delivery Receipt form must be completed by the Kinze Dealer and signed by the retail purchaser, with copies to the Dealer, and to the retail purchaser. Registration must be completed and submitted to Kinze Manufacturing, Inc. within 5 business days of delivery of the Kinze product to the retail purchaser. Kinze Manufacturing, Inc. reserves the right to refuse warranty on serial numbered products which have not been properly registered.

If service or replacement of failed parts which are covered by the Limited Warranty are required, it is the user's responsibility to deliver the machine along with the retail purchaser's copy of the Warranty And Delivery Receipt to the Kinze Dealer for service. Kinze warranty does not include cost of travel time, mileage or hauling. Any prior arrangement made between the Dealer and the retail purchaser in which the Dealer agrees to absorb all or part of this expense should be considered a courtesy to the retail purchaser.

Kinze warranty does not include cost of travel time, mileage, hauling, or labor.

Always give your dealer the serial number of your Kinze product when ordering parts or requesting service or other information.

The serial number is located on the machine as shown in the diagram below. In the space provided record the model number, the serial number and the date of purchase to assist your dealer in providing you with prompt and efficient service.

SERIAL NUMBER: _____

MODEL NUMBER: _____

DATE OF PURCHASE: _____

