

# MAGIC SWITCH: MS21H

Hardwired | Stainless Steel | Touchless | Activation Sensor\*



6" Round (shown)  
 Text & Logo - 10MS21HR1  
 Logo - 10MS21HRL1  
 Text - 10MS21HR

4.75" Square  
 Text & Logo - 10MS21HS1  
 Logo - 10MS21HSL1  
 Text - 10MS21HS

PATENT PENDING

## DESCRIPTION

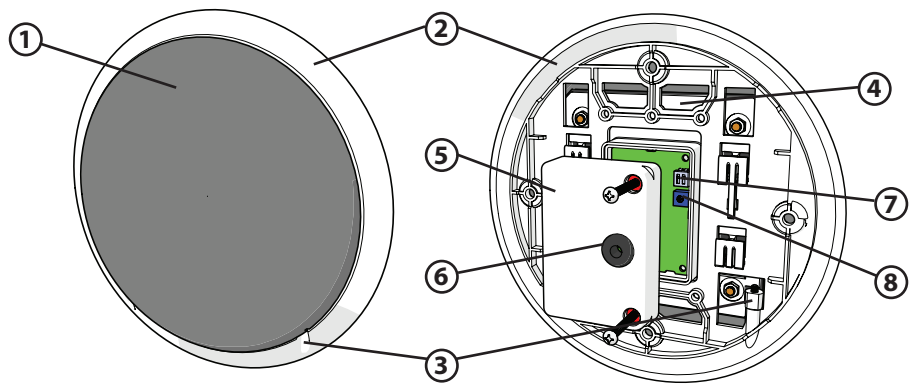

- 1. faceplate
- 2. mounting ring
- 3. set screws
- 4. backplate

- 5. NEMA 4 enclosure
- 6. wire harness
- 7. DIP switches
- 8. potentiometer

## TECHNICAL SPECIFICATIONS \*

Technology	Capacitive Sensing
Detection Mode	Proximity
Supply Voltage	12-24 VAC/DC
Current Consumption	37 mA (typical)
Temperature Range	-20°F to +120°F
Enclosure Rating	NEMA 4
Sensing Zone **	Maximum sensing zone of up to four (4) inches
Relay	1-Form A Solid State Relay 0.4A 60VAC/VDC (max)
Dimensions (Overall)	6" round - 7" (DIA) x 0.5" (D) 4.75" square - 5.75" (H) x 5.75" (W) x 0.5" (D)
Wire Harness Length ***	6 inches (5 conductor)
Material	Stainless Steel (faceplate) Clear Polycarbonate (mounting ring, backplate, enclosure)

Specifications are subject to change without prior notice.

- \*\* Sensing Zone is dependent upon
- Size (area) of object
  - Orientation of object
  - Speed of object
  - Environmental conditions

\*\*\* 5 conduct wire needed between sensor and door control

\* Use of the device outside the intended application cannot be guaranteed by the manufacturer.

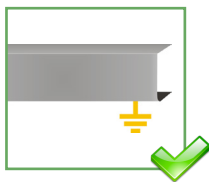

The door control unit and the door cover profile must be correctly grounded.



Only trained and qualified personnel may install and setup the sensor.

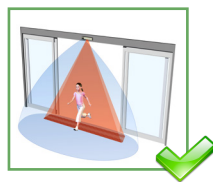

Always test the proper operation of the installation before leaving the premises.



The warranty is invalid if unauthorized repairs are made or attempted by unauthorized personnel.

# 1 INSTALLATION

## TIPS

single or double gang electrical box may be used (non-metallic ideal)

single gang electrical box recommended for 4.75" square version

set screws are 4/40 x 1/2" Allen head screws, adjusted with 3/32 Allen wrench (supplied)

mounting screws are #6-32 x 1/2" Phillips head screws

## APPLICATIONS

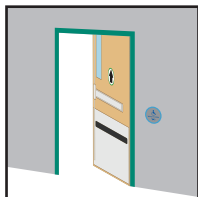

Single Swing Doors

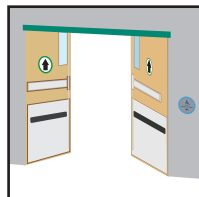

Sim Pair Swing Doors

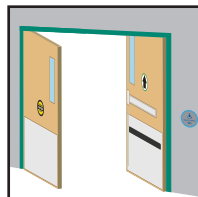

Dual Egress Swing Doors

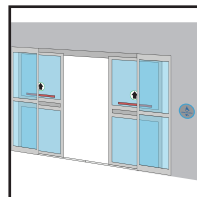

Sliding Doors

**NOTE:** Do not install the sensor within the swingpath of the door.

- 1) Install electrical box
- 2) Remove two (2) set screws
- 3) Disassemble (slide up, pull out) faceplate assembly from mounting ring

4) Temporarily mount mounting ring to electrical box

**NOTE:** Observe "THIS END UP"

5) Mark four (4) mounting ring mounting hole locations

6) Remove mounting ring from electrical box

7) Install four (4) wall anchors

8) Mount (hand tighten) mounting ring to both electrical box and wall

9) Remove back of NEMA 4 enclosure

10) Complete Section 2 (WIRING) and Section 3 (SETTINGS & ADJUSTMENTS) prior to continuing installation in Section 4

## 2 WIRING

### IMPORTANT WIRING NOTES:

Be sure to always use the BEA provided isolation module. \*

If using a shielded wire harness, both ends of the shielding foil must be connected to Earth Ground.

If using a wire harness with more than 5 conductors, all extra conductors must be wired to Earth Ground.

NOTE: It will take approximately 10 seconds to complete the initialization sequence once powered.

\* It is required that each MS21 be powered by a separate isolation module

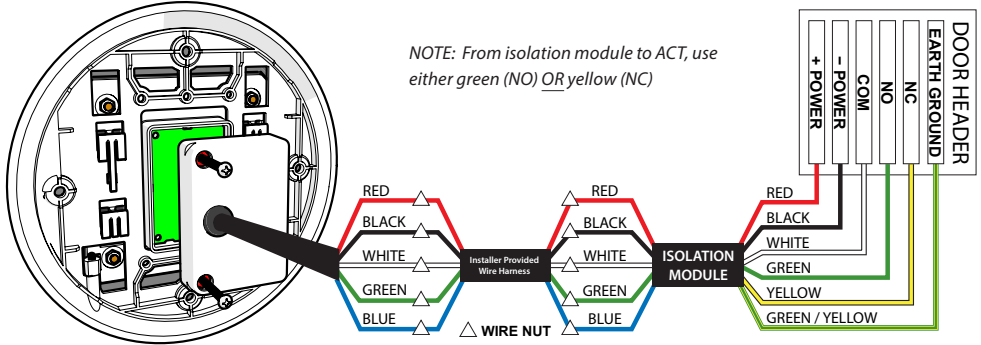

Wire nut harness wires and isolation module wires together and connect isolation module wires to the door control, according to the chart below.

Isolation Module	Signal	Harness Wire	Isolation Module Wire	Door Control Terminal
To Door Control (6 wire side)	AC/DC +	-	Red	AC/DC +
	AC/DC -	-	Black	AC/DC -
	COM	-	White	ACT COM
	NO	-	Green	ACT NO
	NC	-	Yellow	ACT NC
	Earth Ground	-	Green / Yellow	Earth Ground
To MS21 (5 wire side)	COM	White	White	-
	NO	Green	Green	-
	AC/DC	Red	Red	-
	AC/DC	Black	Black	-
	Earth Ground	Blue	Blue	-

## 3 SETTINGS & ADJUSTMENTS

### A - SENSING ZONE - potentiometer

COUNTERCLOCKWISE - decrease (0" minimum)

CLOCKWISE - increase (4" maximum \*)

### B - AUDIBLE ALERT - DIP switch 1 (left)

ON - audible alert pulsed for 0.5 seconds during detection

OFF - audible alert off

### C - LED - DIP switch 2 (right)

ON - LED on at rest, pulsed off for 0.5 seconds during detection

OFF - LED off at rest, pulsed on for 0.5 seconds during detection

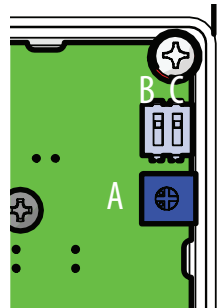

\* Maximum sensing zone will vary depending on size (area), orientation, and speed of object as well as environmental conditions.

## 4 INSTALLATION (continued)

- 11) Reinstall back of NEMA 4 enclosure
- 12) Reassemble (align, push in, slide down) faceplate assembly to mounting ring
- 13) Reinstall two (2) set screws
- 14) Test installation functionality and performance

**CAUTION:** When installing near unprotected and/or uninsulated circuits, additional electrical isolation may be needed. The shrink tubing provided by BEA over the printed wiring board is rated minimum 150V, VW-1 and 80°C. This information may be taken into account to define whether additional isolation is required.

### FUNCTIONALITY

**ACTIVATION** - Activation signal held until sensing zone is cleared (or until relearned). Audible Alert (if enabled) will pulse for 0.5 seconds at initial detection.

**REJECTION** - An object must be within sensing zone for at least 130 milliseconds for detection to occur (i.e. parallel traffic rejection).

**TRACKING** - Reduced unwanted detections by allowing small variations in baseline capacitance (i.e. temperature/humidity changes). If stationary object remains within sensing zone for more than 5 seconds, a new capacitive zone will be learned and normal operation will resume (i.e. chewing gum stuck to faceplate).

### TROUBLESHOOTING

Sensor detecting erratically or false activations	1. Not properly grounded	1. Verify continuity between sensor ground and earth ground. See Application Note for details.
	2. Unstable power supply	2. Be sure to use the BEA isolation module
	3. Electrical noise within sensing zone	3. Reduce sensing zone (potentiometer counterclockwise)
	4. Non-stationary object within detection zone	4. Clear 10" zone around detection field
	5. Sensor has been vandalized	5. Verify sensor is operational; replace if necessary
Sensor not detecting	1. Sensing zone is set too low	1. Increase sensing zone (potentiometer clockwise)
	2. No power	2. Verify power supply and connection

### ANSI / AAADM Compliance American Association of Automatic Door Manufacturers

Upon completion of the installation or service work, at a minimum, perform a daily safety check in accordance with the minimum inspection guidelines provided by AAADM. Provide each equipment owner with an owner's manual that includes a daily safety checklist and contains, at a minimum, the information recommended by AAADM. Offer an information session with the equipment owner explaining how to perform daily inspections and point out the location of power/operation switches to disable the equipment if a compliance issue is noted. The equipment should be inspected annually in accordance with the minimum inspection guidelines. A safety check that includes, at a minimum, the items listed on the safety information label must be performed during each service call. If you are not an AAADM certified inspector, BEA strongly recommends you have an AAADM certified inspector perform an AAADM inspection and place a valid inspection sticker below the safety information label prior to putting the equipment into operation.

The complete declaration of conformity is available on our website: [www.beasensors.com](http://www.beasensors.com)

