

**FUJINON
PROFESSIONAL
LENSES**

FUJI FILM

FUJINON PROFESSIONAL LENSES

that faithfully
reproduce the
photographer's image

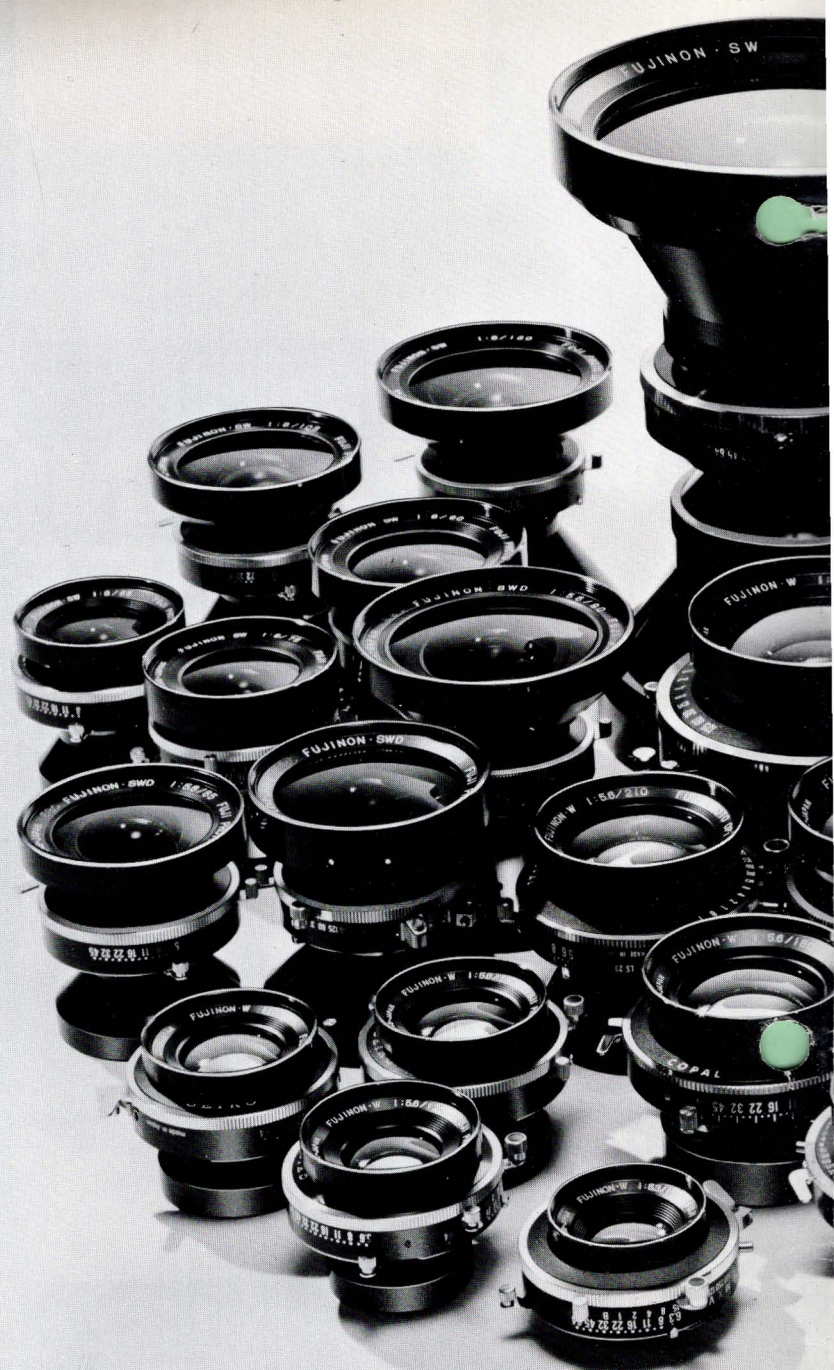

Professional cameras generally take films ranging in size from 6 x 9cm to 8 x 10in. A tremendous number of different lenses would be required to expose these and intermediate sizes with lenses of differing angles of view and focal lengths from ultra wideangle to ultra telephoto.

This problem was analyzed and thoroughly studied from every conceivable angle by Fuji Film's marketing research team. The result is a system of lenses which can cover the widest range of photographic situations with the smallest number of lenses—the Fujinon Lens Series.

Manufactured under a thorough system of quality control all the way from raw optical glass to finished lens, they are optical gems, each of which is characterized by the same superb properties.



The Ultimate in Color Reproduction

Following thorough computer studies on the relationship between lens spectral transmission and color film reproduction, Fuji Film succeeded in perfecting a series of colorless lenses with ideal spectral absorption and transmission over the entire spectrum from ultraviolet to infrared—the world famed Fujinon lenses. Entirely free of blue and yellowish cast, they promise you the ultimate in sharp and clear images.

Superb Definition of Detail

Photographic representations of merchandise and of human subjects require not only that the pictures turn out sharp and clear but that the texture of the subject itself is also faithfully reproduced. The superb resolving power as well

as freedom of objective aberration and internal flare of the Fujinon lenses promise you the ultimate in distortion-free definition of the finest detail.

Ideal Angles of View

The Fujinon·SW with its 100° angle of view and the Fujinon·W with its 80° angle of view enhance the maneuverability of your view camera. They feature perfect edge-to-edge light distribution and freedom from distortion and aberration.

Superbly Efficient Shutter

Fujinon lenses are equipped with the famed Seiko and Copal Shutter. The levers and knobs are functionally located and the wideangle lenses are provided with two sets of aperture scales for the convenience of the user.

Manufacturing Background

FUJINON Professional Lenses are produced by one of the world's largest photographic producers, Fuji Film, at highly integrated and computerized facilities under the credo of "from raw materials to finished products."

1. From Raw Material to Finished Product

This applies to FUJINON Professional Lenses in a very literal sense. And it is a factor that assures consistently high quality for every one of the lenses in the series.

Rigid Quality Control

Fuji Film manufactures its own raw lens blocks. Being an optical glass producer as well as a lens maker, the company can exercise stringent quality control from the very first stage of lens production. It can mix its own chemicals to the exact specifications set by itself; it can melt, pour, cool, crack in perfect accordance with the pre-determined procedure. What is more, the company can set these specifications and manufacturing procedure always with the end products in mind. And never does it have to compromise with quality: it can freely reject raw glass that turns out badly, no matter how minor the apparent imperfections appear to be. The standards of quality inspection here are naturally severe, because the company knows full well that the minutest flaws here could adversely affect the quality of the finished lenses.

Platinum Crucible

As one way of getting maximum purity for its raw glass, Fuji Film utilizes expensive crucibles made of platinum. In most ordinary circumstances, molten glass is set in crucibles of clay. But at super-high temperatures normally encountered in this process, chemical reactions set in between crucible and hot glass—and some clay particles inevitably get into the glass, resulting in that much impurity. It is to avoid this phenomenon—and thereby purchase an extra tiny fraction of purity—that Fuji Film uses platinum crucibles, hundreds of times more expensive though they are. And it is one good measure of how seriously Fuji Film takes quality—and not just in the raw glass making but in every successive stage of lens making such as grinding, polishing, centering, edging, and surface coating.

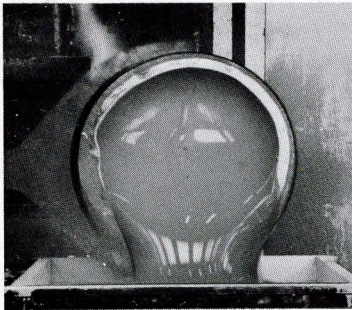

Automatic lens polishers. Hundreds of these units, large and small, are employed at Fuji's Omiya Factory.

2. Well Established in Industry



Some of the optical glass items that come out of Fuji Film's ultra-modern factories.

Fuji Film started manufacture of optical glass at its Odawara Factory back in 1940. In over thirty years, the company established itself as one of the leading optical glass producers in Japan.

The Odawara Factory, which boasts a spacious 89,230 square-meter (960,100 sq. ft.) compounds and 62,096 square meters (668,200 sq. ft.) in building space, turns out some 200 varieties of optical glass and lens blocks. In addition to FUJINON Professional Lenses, these raw glass items eventually go into Fuji Film's numerous optical product lines, such as Fujica Single-8 movie cameras, still cameras, Fujicascope projectors, enlargers and binoculars. Marketed in practically every part of the world, these Fuji optical products have won great acclaim for their high quality and superior performance—which in no small part are the results of Fuji's advanced lens manufacturing technology.

Fuji Film has a wide commitment in the professional field, too. The FUJINON Color Separation System for color TV work is now standard equipment for many of the nation's network TV's. A variety of high-power zoom lenses are also in active use in broadcast TV, industrial TV and 16mm movie making. Other specialized equipment that employs one type of "FUJINON" or another includes: microfilming equipment, photo-engraving machines, Xerographic apparatus, X-ray cameras, gastroscopes.

A final indication of the great heights that Fuji Film has attained in the optical field is that the company supplies basic lens materials and finished products to a large number of Japanese manufacturer of cameras, survey instruments, microscopes, binoculars and others.



The Odawara turns out raw lens blocks . . .



. . . and the Omiya Factory turns them into finished products

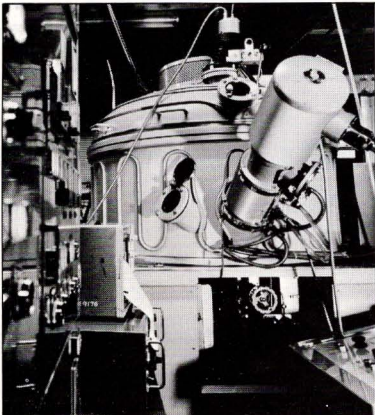

Electron Beam Coating (EBC)

A unique, patented Fuji process

Most quality lenses are coated, but EBC is significantly different in three respects: (1) the number of coats, (2) the thinness of the coatings and (3) the materials used for coating. EBC lenses receive up to 11 coatings on key lens elements, coatings that are exceptionally uniform and thin. Using an electron beam, virtually all ideal coating substances can be melted (including, for example, zirconium oxide — a substance which cannot be used for lens coating with conventional methods).

The final result is up to 99.8% light transmittance, sharper pictures, and virtual elimination of flare and ghost.

1. EBC FUJINON·SWD



A deluxe, super-wideangle lens. Though this lens has a large diameter and ultra-wide angle, image degradation is avoided by a unique Fuji process: Electron Beam Coating (EBC). Glare, flare and ghost are sharply reduced and color balance is exceptionally good.

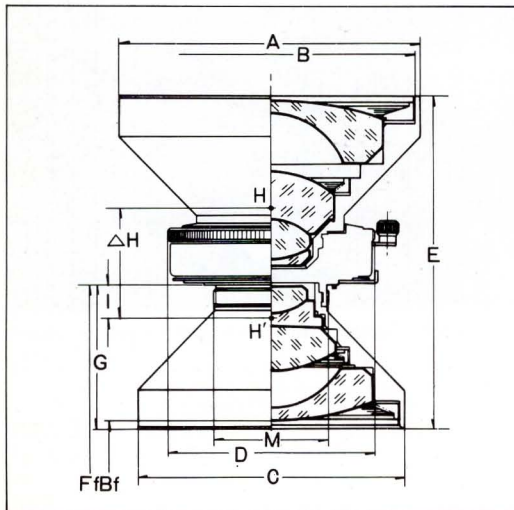

	EBC FUJINON·SWD		
Focal length	65	75	90
Relative aperture	5.6		
Lens composition (comp - elem)	4-8		
Covering power (f/22)	106°		
Image circle (f/22)	172φ	200φ	238φ
Recommended for film size (f/22)	4"x 5"	4 1/4"x 6 1/2"	5"x 7"
Shutter type	Seiko #0		
Shutter speed	B, 1~1/500		
Smallest aperture	45	64	
Press focus lever	Available		
Flash contact	X or M·X		
Designed focal length	65.0	75.2	90.0
Front barrel outer diameter (A)	65φ	70φ	85φ
Filter size (B)	62φ P=0.75	67φ P=0.75	82φ P=0.75
Rear barrel outer diameter (C)	54φ	70φ	75φ
Largest shutter diameter (D)	58.5φ		
Flange mounting screw size (M)	32.5φ P=0.5		
Length of lens (E)	66	75	91
Principal interval (ΔH)	24.1	24.1	33.4
Distance from flange to principal point (I)	7.2	9.3	11.1
Distance from flange to rear barrel end (G)	27	32.5	39
Flange focal length (Ff)	72.2	84.6	101.1
Back focal length (Bf)	46.3	52.9	64.1
Weight (g)	305	380	580

Length unit: mm

2. FUJINON·SW



These six ultra-wide angle lenses range from 65 to 300mm, and include the world's first 105mm lens for 4 × 5 format cameras. All five cover a 100° angle at f/22 and produce pictures that are sharp corner-to-corner. Notable features are virtually perfect aberration correction, compact design, elimination of fringe color diffusion, natural color reproduction and exceptionally good color balance. Each lens is equipped with a press focus lever for rapid shooting.

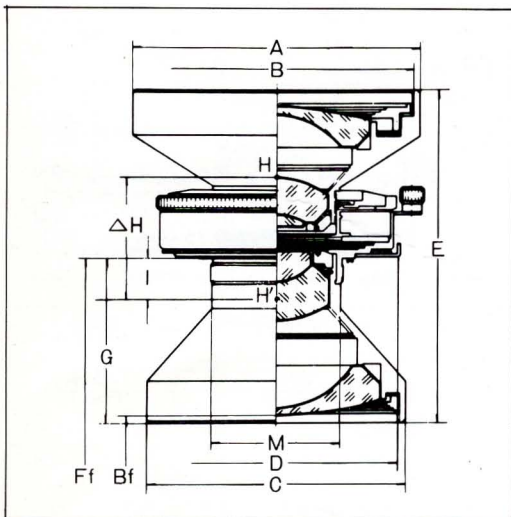

	FUJINON·SW					
Focal length	65	75	90	105	120	300
Relative aperture	8					
Lens composition (comp — elem)	4—6					
Covering power (f/22)	100°					
Image circle (f/22)	155φ	181φ	216φ	250φ	290φ	720φ
Recommended for film size (f/22)	4"× 5"		5"× 7"		6½"× 8½"	18"× 22"
Shutter type	Seiko #0					Copal #3
Shutter speed	B, 1~1/500					T, B, 1~1/125
Smallest aperture	64					
Press focus lever	Available					
Flash contact	X or M·X					X
Designed focal length	64.9	75.0	89.9	105.2	119.8	298.5
Front barrel outer diameter (A)	54φ	60φ	70φ		80φ	150φ
Filter size (B)	52φ P=0.75	58φ P=0.75	67φ P=0.75		77φ P=0.75	145φ P=0.75
Rear barrel outer diameter (C)	48φ	54φ	64φ	70φ	80φ	140φ
Largest shutter diameter (D)	58.5φ					102.4φ
Flange mounting screw size (M)	32.5φ P=0.75					61φ P=0.75
Length of lens (E)	59.4	66.2	78.2	68.5	100.5	215.5
Principal interval (ΔH)	21.3	24.2	29.0	34.4	38.7	79.0
Distance from flange to principal point (I)	6.1	7.5	9.5	11.7	13.5	26.8
Distance from flange to rear barrel end (G)	29.0	32.8	39.5	50.5	52.5	95.0
Flange focal length (Ff)	71.0	82.5	99.4	116.9	133.5	325.3
Back focal length (Bf)	44.1	51.3	61.4	71.5	81.8	229.4
Weight (g)	220	290	379	405	526	3250

Length unit: mm

3. FUJINON·W



Order made Fujinon·W (electronic shutter)

The following are now available on order with electronic shutter. They are built to withstand severe handling without loss of accuracy and are also capable of long exposures up to 32 seconds.

**Fujinon·W 1:5.6 180mm,
Fujinon·W 1:5.6 210mm,
Fujinon·W 1:6.7 250mm.**

Shutter: Copal No.1 electronic shutter
Shutter Speed: B, 32—1/400 sec.
Minimum Aperture: 64
Press Focus Lever: Available
Flash Contact: X
Battery: Eveready No.544, 6V

These nine lenses range from 125 to 360mm, and include the new 125mm lens for 5 × 7 format. All nine cover an area 10 degrees larger than those of competitive brands, and with their 80 degree coverage this series is suitable for long and short distance work. Abberation and, glare are close to zero. High resolving power and rich gradation combine to give faithful reproduction of colors and textures. Appropriate for both hard and soft tone work, these flexible lenses make a fine group of all-purpose professional units.

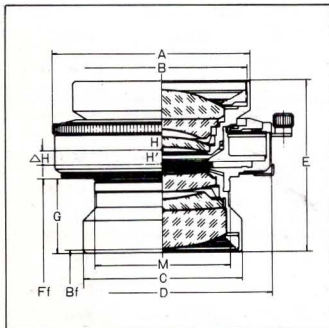

	FUJINON·W									
Focal length	150	125	135	150	180	210	250	300	360	
Relative aperture	6.3	5.6			6.7		5.6	6.3		
Lens composition (comp — elem)	3—4	4—6								
Covering power (f/22)	67°	80°								
Image circle (f/22)	198φ	210φ	228φ	245φ	305φ	352φ	398φ	420φ	485φ	
Recommended for film size (f/22)	4¾"× 6½"	5"× 7"		6½"× 8½"	8"× 10"		10"× 12"		11"× 14"	
Shutter type	Seiko #0				Copal #1			Copal #3		
Shutter speed	B, 1~1/500				B, 1~1/400			T, B, 1~1/125		
Smallest aperture	64							90		
Press focus lever	Available									
Flash contact	X or M·X							X		
Designed focal length	150.5	124.7	134.7	149.5	180.0	210.3	250.0	299.1	359.2	
Front barrel outer diameter (A)	42φ	48φ			60φ	70φ	80φ	90φ		
Filter size (B)	40.5φ P=0.5	46φ P=0.75			58φ P=0.75	67φ P=0.75	77φ P=0.75	86φ P=1.0		
Rear barrel outer diameter (C)	31φ	39φ	45φ		54φ	60φ	64φ	70φ	80φ	
Largest shutter diameter (D)	58.5φ				73.0φ			102.4φ		
Flange mounting screw size (M)	32.5φ P=0.5				39φ P=0.75			61φ P=0.75		
Length of lens (E)	33.3	45.2	45.4	49.4	59.3	67.0	78.5	95.0	113.5	
Principal interval (ΔH)	1.9	3.3	3.6	4.0	4.8	5.6	6.7	8.0	9.6	
Distance from flange to principal point (I)	7.0	3.4		3.5	4.3	3.7	3.9	6.2	6.5	
Distance from flange to rear barrel end (G)	9.1	19.0	19.8	22.4	27.6	32.0	38.0	43.8	53.8	
Flange focal length (Ff)	143.5	121.3	131.3	146.0	175.7	209.6	246.1	292.9	352.7	
Back focal length (Bf)	137.3	104.4	112.8	125.2	150.8	176.3	209.5	250.5	300.8	
Weight (g)	180	150	207	227	410	503	690	1228	1533	

Length unit: mm

4. FUJINON·L



The three lenses in this series have respective focal lengths of 210, 300, and 420mm. All are compact, economical, and, despite their long focal lengths, have a wide coverage approaching that of a normal lens. Furthermore, unlike conventional Tessar-type lenses, these units have unusually high resolving power. With rich gradation, fine detail definition and excellent color balance, this series is ideal for color portrait work where accurate exposure is crucial. Each lens has a press focus lever for rapid shooting.

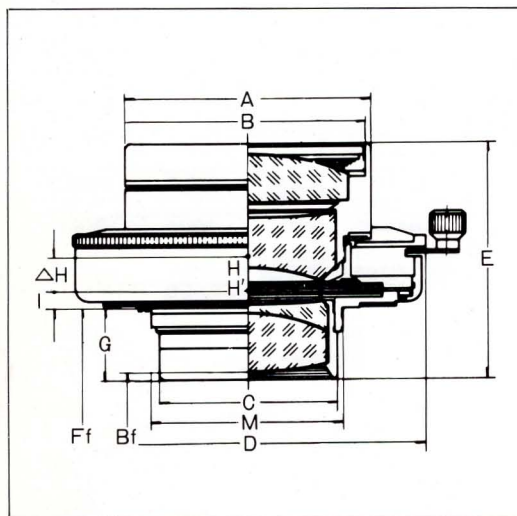

	FUJINON·L		
Focal length	210	300	420
Relative aperture	5.6		8
Lens composition (comp - elem)	4-4		
Covering power (f/22)	59°		53°
Image circle (f/22)	240φ	343φ	480φ
Recommended for film size (f/22)	5" x 7"	8" x 10"	10" x 12"
Shutter type	Copal #1	Copal #3	
Shutter speed	T.B.1~1/400	T,B,1~1/125	
Smallest aperture	64		
Press focus lever	Available		
Flash contact	X or M·X	X	
Designed focal length	206.5	301.0	420.9
Front barrel outer diameter (A)	51φ	70φ	
Filter size (B)	49φ P=0.75	67φ P=0.75	
Rear barrel outer diameter (C)	37φ	60φ	
Largest shutter diameter (D)	73φ	102.4φ	
Flange mounting screw size (M)	39φ P=0.75	61φ P=0.75	
Length of lens (E)	49.0	74.0	88.2
Principal interval (ΔH)	7.9	11.5	10.4
Distance from flange to principal point (I)	13.6	20.3	23.3
Distance from flange to rear barrel end (G)	14.7	22.8	30.0
Flange focal length (Ff)	192.9	280.7	397.6
Back focal length (Bf)	179.6	261.8	371.3
Weight (g)	320	800	900

Length unit: mm

5. FUJINON·A



These four lenses range from 180 to 1200mm and can truly be designated as "super-apochromatic lenses". Special optical glass and special designing went into each of these 6-element units. Residual color aberration has been corrected close to perfection; as a result, despite long focal lengths, these lenses are free from color diffusion. Compact so they can be used for location work, all four lenses will deliver fine performance for long-distance shooting as well as outstanding gradation, detail definition and texture rendition which are essential for close-range and small-subject shooting.

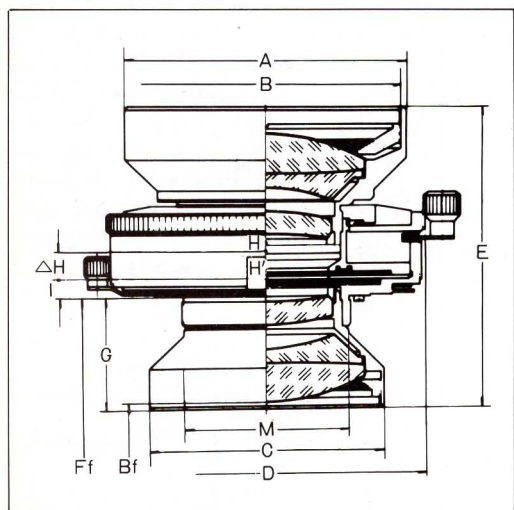

	FUJINON·A			
Focal length	180	240	600	1200
Relative aperture	9		11	
Lens composition (comp - elem)	4-6			
Covering power (f/22)	70°			50°
Image circle (f/22)	252φ	336φ	840φ	1120φ
Recommended for film size (f/22)	6½" x 8½"	8" x 10"	20" x 24"	
Shutter type	Copal #0		Copal #3	
Shutter speed	T,B,1~1/500		T,B,1~1/125	
Smallest aperture	90			
Press focus lever	Available			
Flash contact	X or M·X		X	
Designed focal length	180.3	240.4	603.0	1200.5
Front barrel outer diameter (A)	48φ	54φ	100φ	106φ
Filter size (B)	46φ P=0.75	52φ P=0.75	95φ P=1.0	102φ P=1.0
Rear barrel outer diameter (C)	37φ	45φ	95φ	106φ
Largest shutter diameter (D)	61φ		102.4φ	
Flange mounting screw size (M)	32.5φ P=0.5		61φ P=0.75	
Length of lens (E)	45.0	55.0	131.1	177.5
Principal interval (ΔH)	2.3	3.1	9.1	16.1
Distance from flange to principal point (I)	2.1	2.5	0.6	1.8
Distance from flange to rear barrel end (G)	16.7	21.7	59.5	82.3
Flange focal length (Ff)	178.2	237.9	603.3	1202.3
Back focal length (Bf)	163.3	217.6	546.0	1125.5
Weight (g)	170	225	1710	2600

Length unit: mm

6. FUJINON·SF



These three lenses have respectively focal lengths of 180, 250 and 420mm. Ideal for portraiture, these lenses save time and labor because retouching is ordinarily completely unnecessary. Suitable for pictures of the bride or for identification photos. Both are 3-component, 3-element lenses — something unusual in a soft-focus lens. With provision for “softness control”, the Fujinon·SF series offers greater freedom of expression, including techniques such as intentional halo and vignette. Tones are natural and highlights are outstanding.

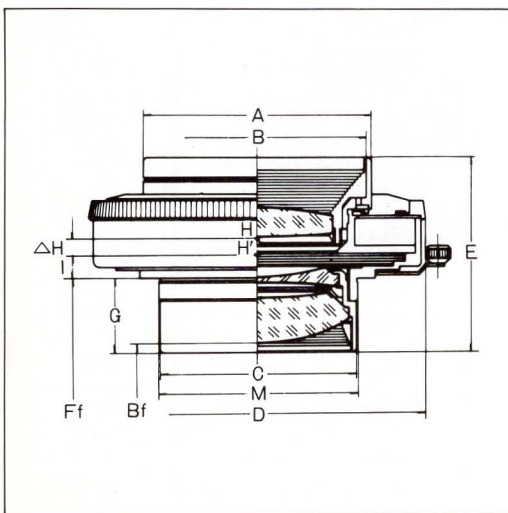

	FUJINON·SF		
Focal length	180	250	420
Relative aperture	5.6		
Lens composition (comp — elem)	3—3		
Covering power (f/22)	58°		
Image circle (f/22)	200φ	300φ	500φ
Recommended for film size (f/22)	4¼" x 6½"	8" x 10"	11" x 14"
Shutter type	Copal #1	Copal #3	—
Shutter speed	B, 1~1/400	T, B, 1~1/125	—
Smallest aperture	22		
Press focus lever	Available		—
Flash contact	X or M·X	X	—
Designed focal length	180.2	250.9	419.1
Front barrel outer diameter (A)	48φ	70φ	85φ
Filter size (B)	46φ P=0.75	67φ P=0.75	82φ P=0.75
Rear barrel outer diameter (C)	42φ	60φ	85φ
Largest shutter diameter (D)	73φ	102.4φ	—
Flange mounting screw size (M)	39φ P=0.75	61φ P=0.75	90φ P=1.0
Length of lens (E)	42.5	61.0	77.5
Principal interval (ΔH)	2.7	4.3	7.1
Distance from flange to principal point (l)	3.9	6.9	6.1
Distance from flange to rear barrel end (G)	17.6	22.8	18.5
Flange focal length (Ff)	176.3	257.8	413.0
Back focal length (Bf)	159.9	237.7	397.1
Weight (g)	240	550	980

Length unit: mm

7. FUJINON·T



For a telephoto lens, the 400mm Fujinon·T offers extraordinary sharpness and color balance. The quality of its color rendition equals that of medium wideangle lenses. This lens may be used as an effective replacement for an L-type lens mounted on a short bellows camera. This carefully designed lens is compact, compatible with a variety of applications, and particularly valuable in press work.

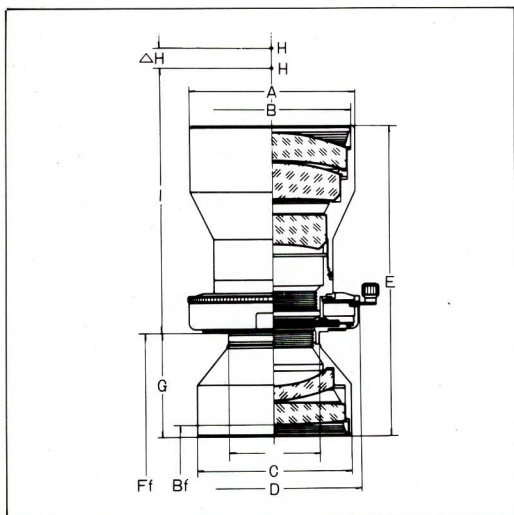

	FUJINON·T
Focal length	400
Relative aperture	8
Lens composition (comp - elem)	5-5
Covering power (f/22)	33°
Image circle (f/22)	240φ
Recommended for film size (f/22)	5" x 7"
Shutter type	Copal #1
Shutter speed	T, B, 1 ~ 1/400
Smallest aperture	64
Press focus lever	Available
Flash contact	X or M·X
Designed focal length	399.1
Front barrel outer diameter (A)	70φ
Filter size (B)	67φ P=0.75
Rear barrel outer diameter (C)	65φ
Largest shutter diameter (D)	73φ
Flange mounting screw size (M)	39φ P=0.75
Length of lens (E)	130.5
Principal interval (ΔH)	38.7
Distance from flange to principal point (I)	139.9
Distance from flange to rear barrel end (G)	43.6
Flange focal length (Ff)	259.2
Back focal length (Bf)	220.7
Weight (g)	760

Length unit: mm

8. FUJINON



These four lenses range from 180 to 300mm and all are without shutters. All have been used with great satisfaction by professionals for years. With edge-to-edge sharpness, excellent aberration correction, these easy-to-own units are among the most popular for portraiture and group pictures.

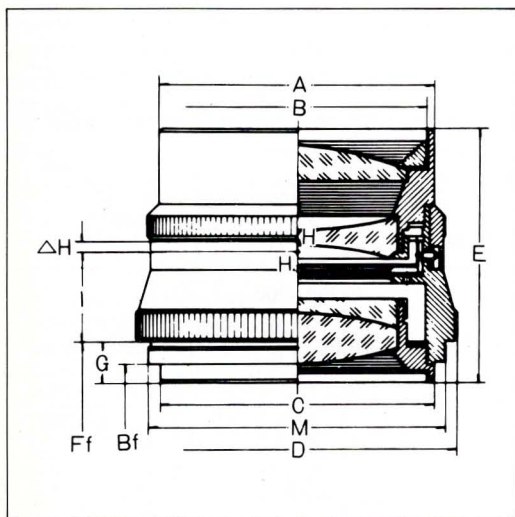

	FUJINON			
	180	210	250	300
Focal length	180	210	250	300
Relative aperture	4.5			
Lens composition (comp - elem)	3-4			
Covering power (f/22)	59°			
Image circle (f/22)	205φ	240φ	286φ	343φ
Recommended for film size (f/22)	4¾" x 6½"	5" x 7"	6½" x 8½"	8" x 10"
Shutter type	-			
Shutter speed	-			
Smallest aperture	64			
Press focus lever	-			
Flash contact	-			
Designed focal length	180.1	209.7	248.0	299.1
Front barrel outer diameter (A)	51φ	60φ	70φ	85φ
Filter size (B)	49φ P=0.75	58φ P=0.75	67φ P=0.75	82φ P=0.75
Rear barrel outer diameter (C)	51φ	57φ	70φ	85φ
Largest shutter diameter (D)	61φ	69φ	82φ	97φ
Flange mounting screw size (M)	56φ P=1.0	62φ P=1.0	75φ P=1.0	90φ P=1.0
Length of lens (E)	49	56.5	67	81
Principal interval (ΔH)	1.6	1.8	1.7	2.1
Distance from flange to principal point (I)	16.6	21.1	24.8	30.4
Distance from flange to rear barrel end (G)	9.5	10	12	13
Flange focal length (Ff)	163.6	188.6	223.2	268.7
Back focal length (Bf)	157.5	183.5	215.5	259.8
Weight (g)	254	386	641	1010

Length unit: mm

9. FUJINON·EP



Fujinon·EP lenses boast an elaborate 4-component, 6-element symmetrical design, and offer faithful corner-to-corner reproduction of negatives. Color aberration is fully corrected to the near-ultraviolet range; their sharpness and detail definition are truly excellent—with room to spare at full aperture. They are fine enlarger lenses for such work as photomurals, microfilm blow-ups and map-making. The six focal length: 38mm, 50mm, 75mm, 90mm, 105mm and 135mm.

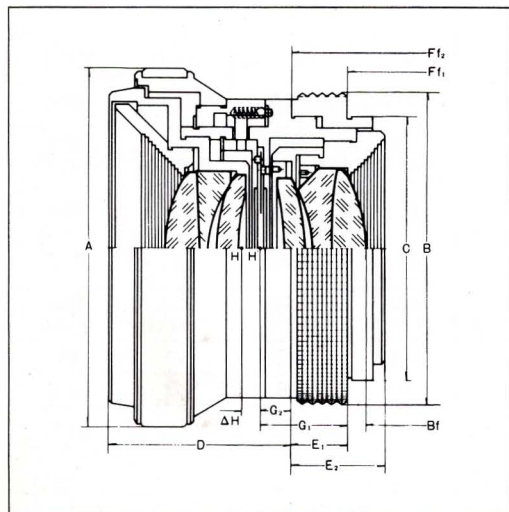

	FUJINON·EP					
Focal length	38	50	75	90	105	135
Relative aperture	4.5	3.5	5.6			
Lens composition (comp — elem)	4—6					
Covering power	56°					
Recommended negative size (open)	24x24	24x36	56x56	56x84	65x90	100x125
Smallest aperture	22					45
Designed magnification	10		7		5	
Useful magnification range	3—35	2—20	1.5—15		1.5—10	
Achromatized wavelength range (nm)	380—700					
Distortion at basic magnification (%)	0	0.03	-0.06	-0.05	-0.06	-0.02
Designed focal length	38.0	51.6	76.3	90.0	104.7	135.5
Barrel outer diameter (A)	54φ	53φ				60φ
(B)	47φ	46φ				53φ
Flange mounting screw size (C)	39φ P=1					
(D)	24	27				38.5
Length of lens (E ₁)	7.9	7	7	9.5		6.5
(E ₂)	—	12	12.3	15.3	16.3	—
Flange focal length (Ef ₁)	32.9	37	67	78.6	92.1	117.8
(Ef ₂)	—	44	74	88.1	101.6	—
Back focal length (Bf)	26.2	34.2	64.1	75.7	88.0	112.56
Distance from flange (G ₁) to principal point (G ₂)	5.1	14.6	9.3	11.4	12.6	17.7
(G ₂)	—	7.6	2.3	1.9	3.1	—
Principal interval (ΔH)	-5.7	-7.8	0.58	0.69	0.81	3.33
Weight (g)	181	134	122	126	132	205

Length unit: mm

10. FUJINON·ES



The five enlarger lenses in the Fujinon·ES series may be called economy-type lenses, both in price and simplicity of use. They have been the best-selling enlarger lenses in Japan for the past 20 years. Fully corrected for color aberration, They reproduce negatives in sharp, clear details. Focal length: 50mm, 75mm, 90mm, 105mm and 135mm.

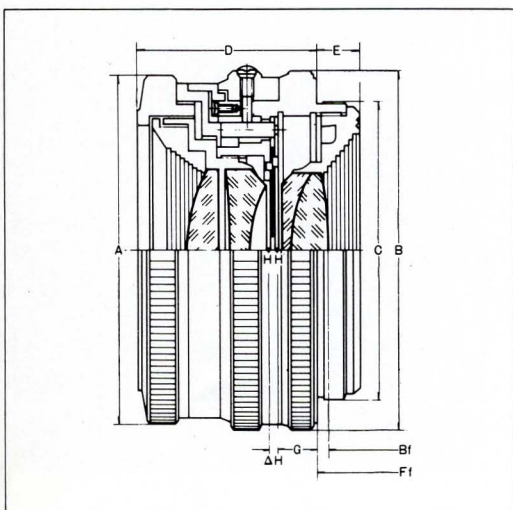

	FUJINON·ES				
Focal length	50	75	90	105	135
Relative aperture	4.5				
Covering power	50°				
Recommended negative size	24x36	56x56	56x72	56x84	100x125
Smallest aperture	22				
Designed magnification	10	7		5	
Useful magnification range	2-20	1.5-15		1.5-10	
Achromatized wavelength range (nm)	387-700				
Distortion at basic magnification (%)	0.09				
Designed focal length	50.4	76.5	89.0	104.8	134.7
Lens barrel outer diameter (A)	46φ				54φ
(B)	47φ				54φ
Flange mounting screw size (C)	39φ P=1				
Length of lens (D)	24		25		28.5
(E)	6.2	5.8	5.9	5.8	6.5
Flange focal length (Ff)	42.8	67.0	78.6	92.1	120.8
Back focal length (Bf)	44.4	66.1	74.4	88.3	115.3
Distance from flange to principal point (G)	7.6	9.5	10.4	12.7	14.0
Principal interval (ΔH)	0.4	0.9	-0.1	-0.2	4.23
Weight (g)	158.5	122	125	127.5	141

Length unit: mm

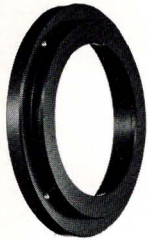

Fujinon Adapter Ring C-1

An optional accessory for mounting Fujinon Professional Lenses with Copal No. 1 Shutter on cameras which take a small lens panel such as the Horseman Press camera.

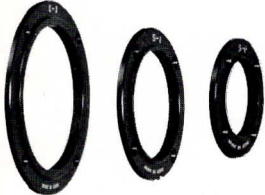

Lens Mounting Adapter

S-0: For Seiko #0 Shutter

S-1: For Seiko #1 Shutter

C-3: For Copal #3 Shutter

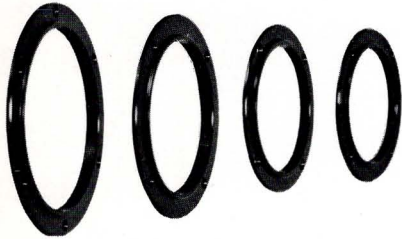

For 180mm lens/210mm lens/250mm lens/
300mm lens (common to SF 420mm lens).

FUJI FILM

FUJI PHOTO FILM CO., LTD.

26-30, Nishiazabu 2-chome, Minato-ku, Tokyo 106, Japan

(FUJI FILM ABROAD)

IN NORTH AMERICA:

IN EUROPE:

IN SOUTH AMERICA:

IN ASIA:

NEW YORK, HONOLULU

DÜSSELDORF, LONDON

SÃO PAULO,

HONG KONG, SINGAPORE,

BANGKOK, TAIPEI, SEOUL

Ref. No. OP1-77E (宣海-76-11-SA-MW)

Printed in Japan