

# **Moisture analyser XM 50**

## *Operating Instructions*



## Declaration of conformity

**Declaration of conformity for apparatus with CE mark**  
**Konformitätserklärung für Geräte mit CE-Zeichen**  
**Déclaration de conformité pour appareils portant la marque CE**  
**Declaración de conformidad para aparatos con disitintivo CE**  
**Dichiarazione di cofnromità per apparecchi contrassegnati con la marcatura CE**

<b>English</b>	We hereby declare that the product to which this declaration refers conforms with the following standards.
<b>Deutsch</b>	Wir erklären hiermit, dass das Produkt, auf das sich diese Erklärung bezieht, mit den nachstehenden Normen übereinstimmt.
<b>Français</b>	Nous déclarons avec cela responsabilité que le produit, auquel se rapporte la présente déclaration, est conforme aux normes citées ci-après.
<b>Español</b>	Manifestamos en la presente que el producto al que se refiere esta declaración est''a de acuerdo con las normas siguientes
<b>Italiano</b>	Dichiariamo con ciò che il prodotto al quale la presente dichiarazione si riferisce è conforme alle norme di seguito citate.

**Moisture Balance: Precisa XM 10 SE**  
**Precisa XM 50**  
**Precisa XM 60, XM 60-HR**  
**Precisa XM 66**  
**Precisa XM 120M, XM 120M-HR**  
**Precisa EM 120-HR**

**with infrared radiator, halogen radiator or dark radiator**

Mark applied	EU Directive	Standards
	2014/30/EU 2014/35/EU	EN61326 EN61010

Date: 20.04.2016

Signature:



R. Grolmund R & D Manager

Precisa Gravimetrics AG , Moosmattstrasse 32 , Postfach 352 , CH-8953 Dietikon

# Identification

## Customer Service

Precisa Gravimetrics AG  
Moosmattstrasse 32  
CH-8953 Dietikon  
Tel. +41-44-744 28 28  
Fax. +41-44-744 28 38  
email [service@precisa.ch](mailto:service@precisa.ch)

<http://www.precisa.com>

For information on local customer service centers check our website.

## Copyright

These Operating Instructions are protected by copyright. All rights reserved. No part of the Operating Instructions may be reproduced, processed, duplicated or published in any form by photocopying, microfilming, reprinting or other process, in particular electronic means, without the written agreement of Precisa Gravimetrics AG.

© Precisa Gravimetrics AG, 8953 Dietikon, Switzerland, 2019

## ■ Overview

# Overview

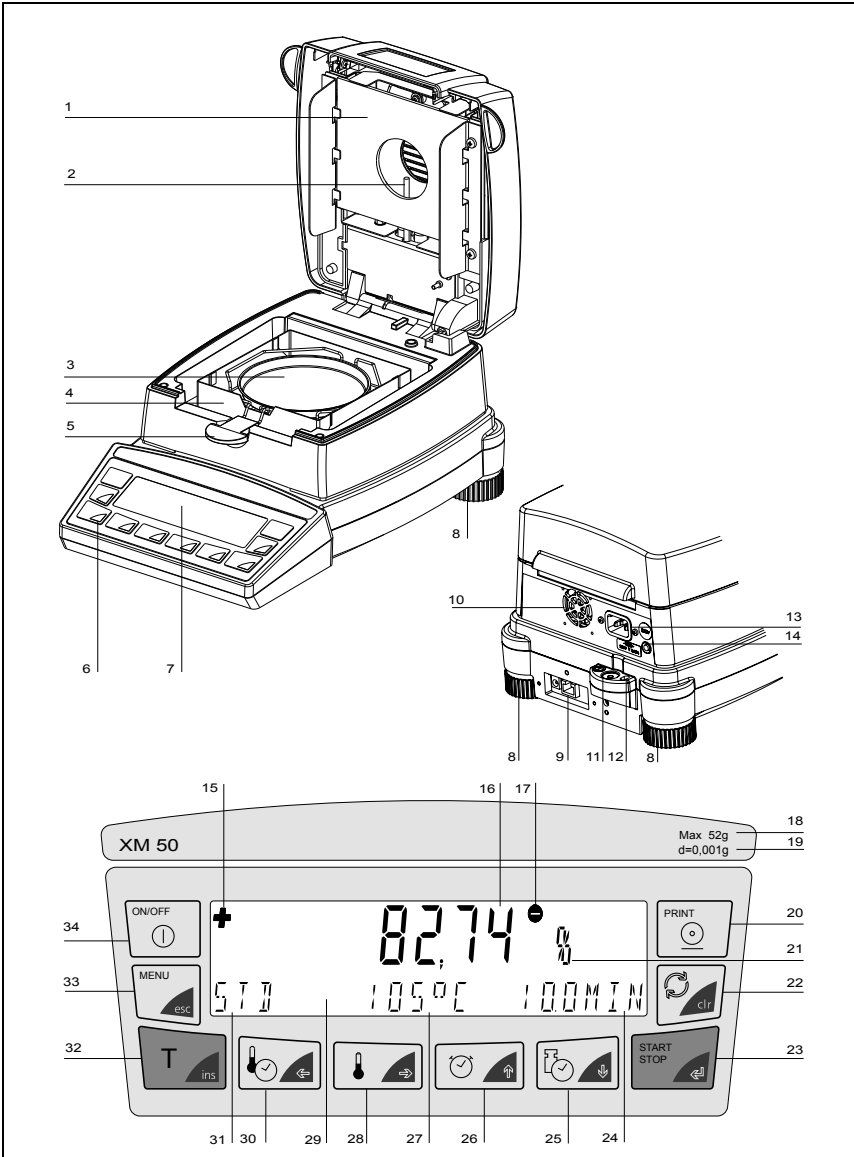

No.	Description	Section
1	Heater	6.1
2	PT100 temperature sensor	8.3.2
3	Weighing pan	3.3 / 6.2
4	Draftshield	3.3
5	Sample holder	3.3
6	10-key membrane keypad	5.1
7	Display	4
8	Rotating adjustable feet	3.7
9	Serial interface, RJ45 socket	7.1
10	Fan	4
11	Levelling bubble	3.7
12	Mechanical anti-theft protection	
13	Mains connection socket	3.5
14	Mains fuse	8.2
15	Prefix display	5.4.4 / 5.4.6
16	Measurement display	4
17	Starting weight	5.4.3
18	Weighing range	9.1
19	Readability	9.1
20	Print key	5.5.2
21	Unit display	5.4.4
22	Change key	5.5.3
23	Start / Stop key	5.5.4 / 6.2.1
24	Drying time display	4
25	Stop mode key	6.3.4
26	Time key	6.3.3
27	Temperature display	4
28	Temperature key	6.3.2
29	Info line	4
30	Heat mode key	6.3.1
31	Heat mode display	4
32	Tare key	5.5.1
33	Menu key	5.3.1 / 5.4.1
34	ON / OFF key	4

## ■ *Table of Contents*

	Identification .....	1
	Overview .....	2
<b>1</b>	<b>Introduction .....</b>	<b>7</b>
1.1	Useful tips on the Operating Instructions .....	8
<b>2</b>	<b>Safety .....</b>	<b>9</b>
2.1	Representations and symbols .....	9
2.2	Safety instructions .....	9
<b>3</b>	<b>Set up .....</b>	<b>11</b>
3.1	Unpacking .....	11
3.2	Transport, storage .....	12
3.2.1	Transport and shipping .....	12
3.2.2	Storage .....	12
3.3	Inspection and assembly .....	13
3.4	Choosing a suitable location .....	14
3.5	Connecting it to the mains .....	15
3.6	Safety measures .....	16
3.7	Levelling .....	16
3.8	Weight calibration .....	17
3.9	Firmware and serial number .....	17
<b>4</b>	<b>First measurement .....</b>	<b>18</b>
<b>5</b>	<b>Operation .....</b>	<b>21</b>
5.1	Menu control operation principle .....	21
5.2	Setting and saving the configuration .....	23
5.3	Instrument configuration .....	23
5.3.1	Activating the configuration menu .....	24
5.3.2	Language function .....	24
5.3.3	Configuring the report printout .....	24
5.3.4	Configuring the application menu .....	26
5.3.5	Balance calibration .....	27
5.3.6	Temperature calibration .....	27

5.3.7	Stability .....	27
5.3.8	Quick-start .....	27
5.3.9	Interface functions .....	28
5.3.10	Date and time .....	28
5.3.11	Password protection .....	29
5.3.12	Anti-theft encoding.....	31
5.3.13	Key tone .....	31
<b>5.4</b>	<b>Application menu operation .....</b>	<b>32</b>
5.4.1	Activating the application menu .....	32
5.4.2	Methods .....	32
	Setting method name.....	33
5.4.3	Starting weight .....	33
5.4.4	Units .....	34
5.4.5	Print rate .....	35
5.4.6	Standby temperature .....	35
5.4.7	Autostart .....	36
<b>5.5</b>	<b>Special operating keys .....</b>	<b>37</b>
5.5.1	The tare key .....	37
5.5.2	The print key .....	38
5.5.3	The change key .....	39
5.5.4	The start/stop key .....	39
<b>6</b>	<b>Determining moisture levels .....</b>	<b>41</b>
<b>6.1</b>	<b>Fundamental principles.....</b>	<b>41</b>
6.1.1	Adjusting to the existing measuring process .....	42
<b>6.2</b>	<b>Sample preparation.....</b>	<b>42</b>
6.2.1	Preventing samples being encrusted .....	43
<b>6.3</b>	<b>Setting drying parameters.....</b>	<b>44</b>
6.3.1	Heating program .....	44
6.3.2	Temperature .....	47
6.3.3	Timer stop.....	47
6.3.4	Switch-off criteria .....	47
<b>6.4</b>	<b>Statistics.....</b>	<b>49</b>
6.4.1	Print statistics.....	49
6.4.2	Reset statistics .....	50
<b>7</b>	<b>Data transfer .....</b>	<b>51</b>

## ■ *Table of Contents*

<b>7.1</b>	<b>Connection scheme .....</b>	<b>52</b>
<b>7.2</b>	<b>Remote control commands .....</b>	<b>53</b>
7.2.1	Examples of the remote control of the instrument.....	54
<b>8</b>	<b>Service .....</b>	<b>55</b>
<b>8.1</b>	<b>Maintenance and servicing .....</b>	<b>55</b>
<b>8.2</b>	<b>Replacing the mains fuse .....</b>	<b>56</b>
<b>8.3</b>	<b>Calibration .....</b>	<b>57</b>
8.3.1	Balance calibration.....	57
8.3.2	Temperature calibration.....	59
8.3.3	Temperature test.....	61
<b>8.4</b>	<b>Firmware update .....</b>	<b>62</b>
<b>8.5</b>	<b>Error messages.....</b>	<b>63</b>
8.5.1	Notes on correcting faults.....	63
<b>9</b>	<b>Overview .....</b>	<b>65</b>
<b>9.1</b>	<b>Technical data.....</b>	<b>65</b>
<b>9.2</b>	<b>Accessories .....</b>	<b>67</b>
<b>9.3</b>	<b>Menu .....</b>	<b>68</b>
9.3.1	Configuration menu tree.....	68
9.3.2	Application menu tree .....	70
9.3.3	Key menus .....	71
9.3.4	Setting drying parameters.....	72
9.3.5	Setting and saving the configuration .....	72
<b>9.4</b>	<b>Index .....</b>	<b>74</b>



# 1 Introduction

The moisture analyser is simple and functional to operate. It is used as a quick and reliable means of determining the moisture content in powders and liquids by the thermogravimetric principle.

The key features of the moisture analyser:

- high-end balance technology built to the highest international standard
- optimum resolution
- easy-to-read vacuum fluorescent display
- large viewing window for perfect sample monitoring
- automatic detection that the measurement has ended by means of ADAPTSTOP
- password protection to prevent unauthorized changes to the instrument configuration and drying parameters
- anti-theft code
- printout in line with GLP guidelines (Good Laboratory Practice)
- software update via the Internet

## ■ 1 Introduction

### 1.1 Useful tips on the Operating Instructions

Take the time to read these Operating Instructions from start to finish so that you can make full use of the many benefits and possibilities of the device in your day-to-day work.

These Operating Instructions contain guidance in the form of pictographs and keypad diagrams, which should help you in finding the required information:

- Key names are presented inside quotation marks and are highlighted in bold font: «**ON/OFF**» or «».
- In order to aid clarity in the explanation of the operating steps, the display for each step is shown graphically on the left alongside the list of operating steps:

**Display**

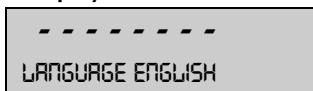

**Key**



**Step**

*Press repeatedly, until the language currently activated is displayed.*

## 2 Safety

### 2.1 Representations and symbols

Important safety-related instructions are highlighted visually at the description of what to do:

 <b>DANGER</b>
<b>Warning of a possible danger which may lead to death or to serious injury.</b>

 <b>CAUTION</b>
<b>Warning of a possible danger which may lead to minor injury or damage.</b>

 <b>NOTE</b>
Tips and important rules on how to use the moisture analyser correctly.

### 2.2 Safety instructions

- When using the instrument in surroundings with increased safety requirements, pay careful attention to the appropriate regulations.
- Only use an extension cord with a protective earth conductor.
- If the mains cord is damaged, disconnect the instrument from the electrical supply immediately and replace the mains cord.
- If there is any reason to believe that it is no longer possible to operate the moisture analyser safely, unplug the instrument immediately from the electrical supply and secure it so that it cannot be operated inadvertently.
- When carrying out maintenance work, it is essential to heed the tips in see chapter 8.1 "Maintenance and servicing".
- The Operating Instructions must be read by everyone who has to operate the instrument and must be kept handy on-site at all times.

## ■ 2 Safety



### **DANGER**

Do not place any flammable materials on, under or beside the instrument.

Leave enough clear space around the instrument to prevent a build-up of heat.

The moisture analyser may not be used to analyze explosive, highly flammable samples.

Do not operate the moisture analyser in areas where there is any risk of explosion.

Sample materials which release toxic substances must be dried in a fume hood. Take care not to inhale any harmful vapors.

Ensure that no liquid seeps inside the instrument or into the connection ports on the back of the instrument.

If you spill any liquid onto the instrument, unplug it from the electrical supply immediately.

Do not operate the moisture analyser again until you have had it checked by a Precisa service engineer.



### **CAUTION**

Some of the parts, like the heating element and the viewing window, may become considerably hotter while it is in operation. Only touch the instrument using the handles provided.

Take care when you remove the sample. The actual sample, the heating unit and sample pans used may still be very hot.

The moisture analyser should generally be used for drying substances containing water. Sample materials which give off aggressive vapors (like acids) may cause corrosion problems to develop on parts of the instrument.

If any damage or injury occurs, liability and responsibility rest with the user.

## 3 Set up

### 3.1 Unpacking

The moisture analyser comes in environmentally-friendly packaging, specifically developed for this precision instrument, which provides optimum protection for the instrument during transportation.



#### NOTE

Retain the original packaging in order to avoid the moisture analyser becoming damaged in transit when it is shipped or transported and to store the device under optimum conditions if it is out of operation for an extended period.

Follow instructions carefully when you unpack the moisture analyser in order to avoid damaging it:

- Unpack the instrument carefully and gently. This is a precision instrument.
- When temperatures outside are very low, the balance should first be stored for a few hours in the unopened transport package in a dry room at normal room temperature, so that no condensation settles on the balance when it is unpacked.
- Check the moisture analyser for any external visible signs of damage immediately after you unpack it. If you find that it has been damaged in transit, notify your Precisa service agent immediately.
- If the moisture analyser is not being put into operation immediately after purchase, store it in a dry place with minimal fluctuations in temperature (see chapter 3.2.2 "Storage").
- Read these Operating Instructions carefully before operating the balance, even if you have used Precisa equipment before and pay particular attention to the safety instructions (see chapter 2 "Safety").

## ■ 3 Set up

### 3.2 Transport, storage

#### 3.2.1 Transport and shipping

Your moisture analyser is a precision instrument. Treat it with care. Avoid shaking it or subjecting it to any heavy jolts or vibrations during transport.

Avoid serious temperature fluctuations and getting the instrument damp (condensation) during transport.



#### **NOTE**

The moisture analyser should ideally be shipped and transported in its original packaging to avoid damage in transit.

#### 3.2.2 Storage

If you do not intend to use the instrument for a long time, unplug it from the electrical supply, clean it thoroughly (see chapter 8 "Service") and store it in a place that meets the following conditions:

- No serious shaking or vibrations
- No serious fluctuations in temperature
- No direct exposure to sunlight
- No moisture



#### **NOTE**

The moisture analyser should ideally be stored in its original packaging because it gives it optimum protection.

### 3.3 Inspection and assembly

The moisture analyser does not come fully assembled. Once you have unpacked all the parts, check that the delivery is complete and assemble the individual components in the order indicated below.

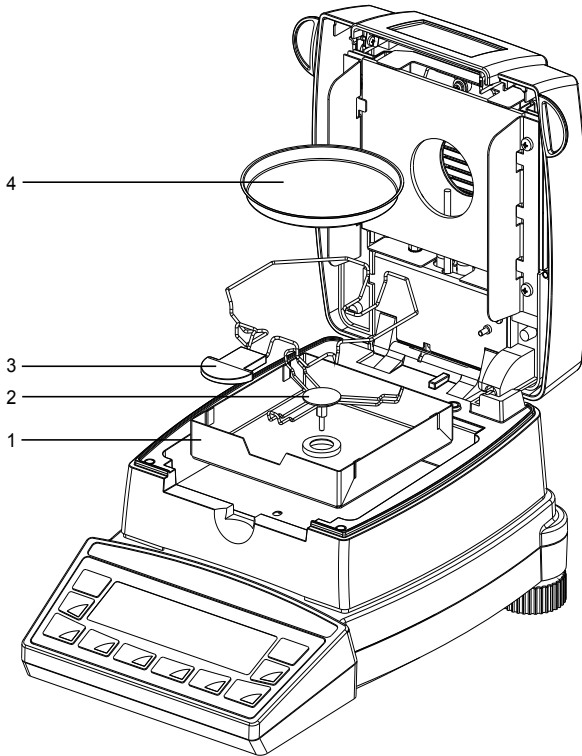

Components delivered	Components delivered
Moisture analyser	Sample holder (3)
Mains cord	30 sample pans (4)
Draftshield (1)	In-use cover for the display
Pan support (2)	Operating Instructions

## ■ 3 Set up

- Assemble the in-use cover for the display
- Open the hood and insert the draftshield (1), making sure that it is placed on flat.
- Insert the pan support (2) and turn it so that it locks securely in place.
- Insert the sample holder (3) as shown.
- You can now place an aluminium pan (4) on the pan support.



### NOTE

All the parts must be attached together without exerting undue force. Do not apply any force. If you have any problems, the Precisa customer service will be happy to help.

## 3.4 Choosing a suitable location

In order to ensure that the moisture analyser functions properly, select a location that fulfils the following criteria:

- Permissible ambient temperatures
  - Temperature: 5°C - 40°C
  - Relative humidity: 25% - 85%, non-condensing
- Put the instrument on a rigid, firm horizontal base, preferably exposed to no vibrations
- Make sure that the instrument cannot be shaken or knocked over
- Do not expose it to direct sunlight and dusty environment
- Avoid drafts and excessive temperature fluctuations
- Leave enough clear space around the instrument to prevent a build-up of heat.

Do not expose the instrument to high levels of moisture for long periods of time. Avoid letting condensation form on the instrument. If instruments are cold, let them warm up to room temperature (approx. 20°C) before connecting them to the mains.

Condensation is practically impossible on instruments which are connected to the mains.



### 3.5 Connecting it to the mains

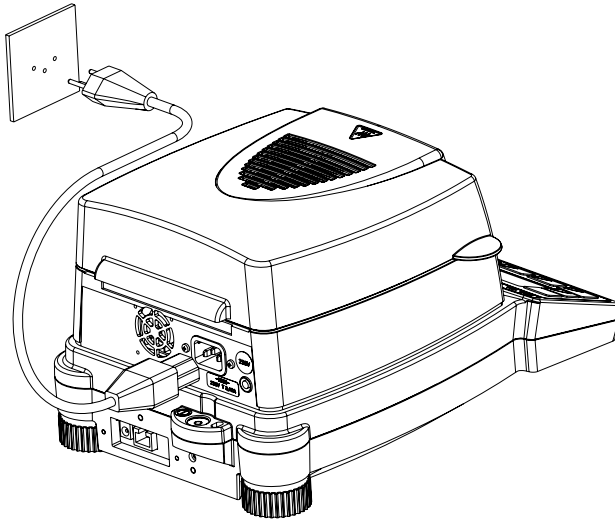

Follow safety instructions when connecting the instrument to the mains:



#### **DANGER**

**The instrument may only be operated using the original mains cord supplied.**

**If the mains cord supplied is not long enough, only use an extension cord fitted with a protective earth conductor.**

**Plug the mains cord into a socket which has been installed in accordance with regulations and is fitted with a PE terminal.**

For technical reasons, the heating unit is designed in the factory to accommodate a voltage of 230 V or 115 V and in accordance with your order. Check that the setting matches the local setting.



#### **NOTE**

**Make sure the instrument has been connected to mains at least for one hour before the first measurement or any calibration.**

## ■ 3 Set up

### 3.6 Safety measures

The safety class 1 instrument, the moisture analyser, may only be plugged into a socket which has been installed in accordance with regulations and is fitted with a protective earth terminal. The safety effect may not be undone by using an extension lead without an earth wire. If the voltage is coming from mains supplies without a protective earth terminal, arrange for an electrician to create a comparable level of protection in accordance with valid installation regulations.

### 3.7 Levelling

In order to function properly, the moisture analyser must be precisely horizontal.

The instrument is fitted with a "levelling bubble" and two rotatable feet for level-control, with the aid of which it is possible to compensate for small height differences and/or unevennesses in the surface on which the instrument is standing.

The two screw feet must be adjusted so that the air bubble is precisely in the center of the sight glass of the levelling bubble.

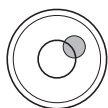

**Incorrect**

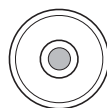

**Correct**



#### **NOTE**

The instrument must be carefully relevelled each time it is moved in order to obtain accurate measurements.

### 3.8 Weight calibration

Since the Earth's gravity is not the same everywhere, each balance must be adjusted to compensate for the gravity at each location, in accordance with the underlying physical weighing principle. This adjustment process, which is known as "calibration", must be carried out on initial installation and then each time the instrument is moved to another location. However, in order to get exact measurements, the instrument should also be recalibrated periodically.



#### NOTE

The moisture analyser must be calibrated when it is initially installed and then each time it is moved to another location. If you work in accordance with "Good Laboratory Practice GLP", observe the prescribed intervals between calibrations (adjustments).

The calibration is set in the configuration menu (see chapter 5.3.5 "Balance calibration").

With the aid of the "Intelligent Calibration Mode" (ICM), the instrument can determine the size of the calibration weight itself, facilitating exact calibration with different size weights (in 10 g increments) (see chapter 8.3.1 "Balance calibration").

### 3.9 Firmware and serial number

After a reconnection of the balance to the mains and switching on for the first time the serial number as well as the firmware will be showed in the upper display.

Display	Remark
<b>4100283</b>	Serie number: 4100283
<b>00,00,P19 c00</b>	Firmware: C00-0000.P19
C00: Hardware code 00,00: Version P19: Release	

## ■ 4 First measurement

# 4 First measurement

Once the moisture analyser is successfully up and running, you can perform an initial measurement to familiarize yourself with the new instrument and to test it for any malfunctions.

Switch the instrument on using the «ON/OFF» key. The instrument performs a self-diagnostics test to check the main functions. After completion of the start-up process (which takes about ten seconds), "Zero" appears in the display; this means that the instrument is now ready for operation.

During the first measurement, the instrument uses the drying parameters set in the factory.

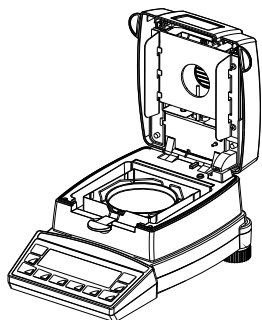

- Open the hood of the instrument
- Place the sample holder with an empty weighing pan onto the weighing pan holder.  
Note: The weighing pan must sit flat on the weighing pan holder. Always work with the sample holder; it allows you to work safely and prevents possible burning ones self.



- Press the «T» key.  
The instrument is ready to weigh the sample.
- Pour approx. 1.0 g of water into the weighing pan.

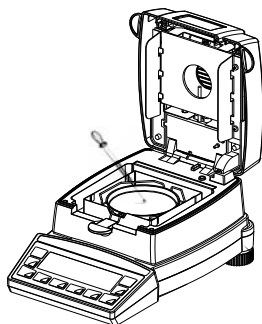

## 4 First measurement ■

- Close the hood

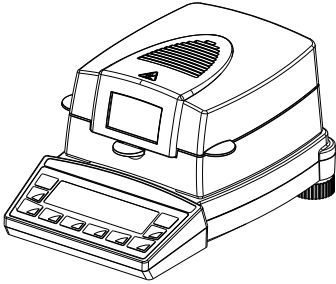

The instrument is prepared for the first measurement.



- Start the measurement by pressing the «**START/STOP**» key.

The heating element heats up to 105°C, and the fan starts to cool.

The moisture analyser display is divided into

the measurement display and

the info line

+	100.00 %	
STD	---°C	0.1MIN

+	93.27 %	
STD	105°C	2.3MIN

- The result appears in the measurement display in the unit of measurement set.
- The info line displays the heating mode used (standard), the current temperature (105°C) and the current duration of the measurement (2.3 min.).  
If the temperature is under 40°C, three dashes are displayed: "---°C".

## ■ 4 First measurement

- Once the drying has ended, an audio signal sounds, and the heating is switched off.

The fan keeps running until the temperature in the sample room drops below 40°C.

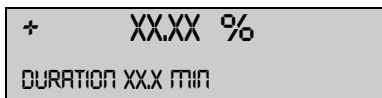

- The measurement display shows the result in the unit of measurement set. The measurement result is displayed in the other units of measurement by pressing the «» key.
- The info line shows how long the measurement takes.
- Open the hood
- Carefully remove the weighing pan, only gripping the sample holder by the handle.

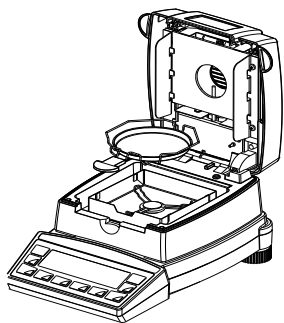

Caution! All the parts of the sample chamber are hot.

Allow the weighing pan and holder to cool down before doing anything else with them.

- Insert a new weighing pan into the instrument.
- Press the «**T**» key; the instrument is ready for you to perform a new measurement.



### CAUTION

The weighing pan and holder are hot!

## 5 Operation

The moisture analyser has two main menus: the configuration menu and the application menu.

Instrument-specific parameters and the layout of the report printout are defined in the **configuration menu**. You can either work with the basic configuration programmed in the factory or define and save a user configuration which is adapted to suit your specific needs.

Moisture Analyser-specific parameters can be set in the **application menu**. The weighing help is also activated and defined in this menu.

### 5.1 Menu control operation principle

The configuration menu and the application menu each have a main path and up to two sub-paths in which the parameters for the different functions of the instrument are defined.

Use the cursor keys «←», «→», «↑» and «↓» to move within the paths.

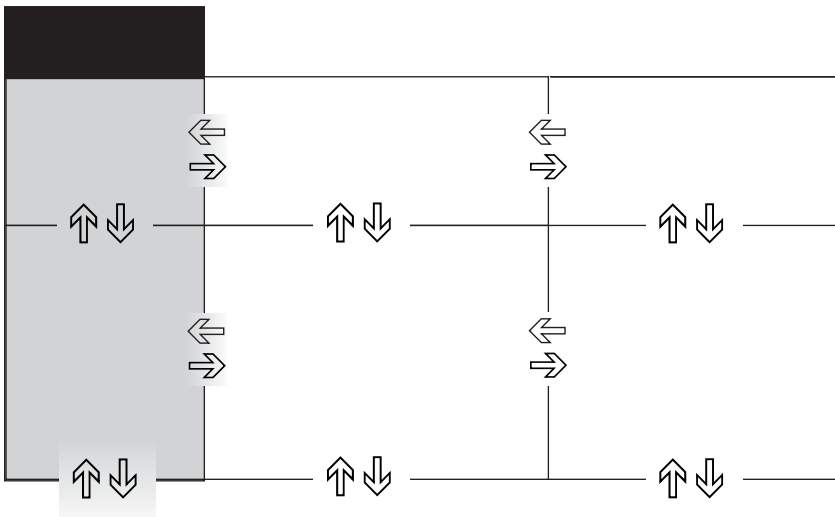









#### NOTE

The geometry of the menu tree diagram corresponds to the path configurations of the two main menus.

## ■ 5 Operation

In **program operation mode**, the **key symbols highlighted in blue** apply on the control panel.

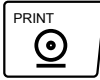
Key(s)	Designation	Function in weighing mode
 	«←», «→»	<ul style="list-style-type: none"> <li>• Changes from the main menu path to the sub-paths and vice versa.</li> </ul>
 	«↑», «↓»	<ul style="list-style-type: none"> <li>• Moving up/down within the main path or sub-paths.</li> <li>• Changing selected parameters</li> </ul>
	«←»	<ul style="list-style-type: none"> <li>• Selecting parameters</li> <li>• Saving the changed parameters</li> </ul>
	«esc»	<ul style="list-style-type: none"> <li>• Cancelling an entry</li> <li>• Exiting the menu</li> </ul>
	«ins»	<ul style="list-style-type: none"> <li>• Setting a space (in text entries)</li> </ul>
	«clr»	<ul style="list-style-type: none"> <li>• Clearing an entry (in text entries)</li> </ul>
	«PRINT»	<ul style="list-style-type: none"> <li>• Entering a decimal point (in text entries)</li> </ul>

The instrument can also be operated by remote control. For details of the remote control commands, see chapter 7.2 "Remote control commands".



## 5.2 Setting and saving the configuration

- Press «**ON/OFF**» to switch the instrument on.
- During the start-up process, keep the «**T**» and «**MENU**» keys pressed in until the configuration you require appears in the display, then let the keys go:
  - "FACTORY CONFIG.": Load the factory configuration.
  - "USER CONFIG.": Load the user configuration.
  - "STORE CONFIG.": Save the current configuration as the user configuration.

## 5.3 Instrument configuration

This section explains the structure of the configuration menu and its functions.

Main path	Definable functions
<b>SET DATA PRINT</b>	<i>Print formats; type of values to print</i>
<b>SET APP. MENU</b>	<i>Defining the application menu</i>
<b>SET BALANCE CAL.</b>	<i>Balance calibration method</i>
<b>TEMP. CAL</b>	<i>Activate the temperature calibration</i>
<b>STABILITY</b>	<i>Instability of the balance location</i>
<b>QUICK-START</b>	<i>Setting the start condition</i>
<b>SET INTERFACE</b>	<i>Baud rate, parity, handshake functions of periphery interface</i>
<b>SET DATE AND TIME</b>	<i>Date and time (standard format or American format p.m. and a.m.)</i>
<b>PASSWORD</b>	<i>Password protection for the menu definitions</i>
<b>THEFTCODE</b>	<i>Activation/deactivation and change to the anti-theft code</i>
<b>KEY TONE</b>	<i>Activation of the keypad sound</i>
<b>LANGUAGE</b>	<i>Language (E, D, F)</i>

- The settings programmed in the factory are depicted in **bold**.
- In order to aid clarity, the only part of the menu tree shown in each function description is the part which relates to the function in question. Explanations on the menu functions are depicted in *italics*.

## ■ 5 Operation



### 5.3.1 Activating the configuration menu

- Press «ON/OFF» to switch the device on.
- Keep the «MENU» key pressed in continuously during the start-up process (which takes about ten seconds) until "SET DATA PRINT" appears in the display.
- You can now change the configuration menu.
- Exit the menu by pressing the «esc»- key.

### 5.3.2 Language function

• LANGUAGE	
SPRACHE DEUTSCH	<i>Selecting a language</i>
<b>LANGUAGE ENGLISH</b>	
LANGUE FRANÇAISE	

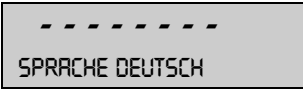
Procedure for changing the language:

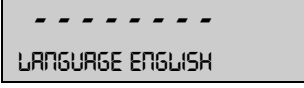
Display	Key	Step
	«↓»	<i>Press repeatedly, until the language currently activated is displayed.</i>
	«←»	<i>The language now flashes.</i>
	«↓»	<i>Press repeatedly until the language you require appears.</i>
	«←»	<i>To confirm the choice of language.</i>

### 5.3.3 Configuring the report printout

The report printout can be configured in the "SET DATA PRINT" menu option. The options marked "ON" are contained in the report and are printed.

The "MODE PC" function allows the measurement printout to be output in a format which the PC can support. This format only affects the print rate printout and is used for the graphical evaluation of the

drying process with the aid of a computer program (such as Excel). The individual measurements are output separated by tabs, allowing them to be imported easily into a table.

<b>• SET DATA PRINT</b>		
	SET PRINTFORMAT	DATE AND TIME <b>ON/OFF</b> BALANCE-ID <b>ON/OFF</b> METHOD-ID <b>ON/OFF</b> COUNTER <b>ON/OFF</b> DRYER SETUP <b>ON/OFF</b> PRINT RATE <b>ON/OFF</b> OPERATOR-ID <b>ON/OFF</b> CAL.-INFO <b>ON/OFF</b>
		PRINTRATE <b>1.0 MIN</b>
		OPERATOR             ttt...
	MODE <b>PRINTER</b>	<i>Printout in text format (40 characters)</i>
	PC	<i>Print rate printout in a format supported by the PC. The individual measurements are separated by a tab.</i>

The elements set in "SET PRINTFORMAT" are printed out.

- The interval at which interim results are printed is set at "PRINT RATE". The print interval can be set in 0.1 min increments from 0.1 - 10.0 min.
- An alphanumeric ID can be entered for the operator at "OPERATOR ttt...".

When a peripheral instrument (e.g. a printer) is connected, the instrument interface must be configured in the "SET INTERFACE" submenu (see chapter 5.3.9 "Interface functions").

## ■ 5 Operation

Example of a report printout with all the available selection options.

***** PRECISA XM 50 ***** -----	<i>Report title, only output in printer mode.</i>
Date 19.10.2018 Time 11:06:09	<i>Date and time, if this is switched on.</i>
Name : XM 50 Heater : Halogen / 50Hz Software : C00-0000 P19 Serialno : 4100283	<i>Balance ID, if this is switched on</i>
Method : Boost/100C	<i>Method ID, if this is switched on</i>
Number : 1	<i>Measurement series counter, if this is switched on</i>
Heat mode : Boost Temperature : 100 C Stop time : 10.0 Min Autostop : 2/20 D/s  Standby temp. : 40 C	<i>Moisture Analyser setup, if this is switched on</i>
Original weight : + 2.186 g	<i>Starting weight is always output</i>
Mode Temp Time 100-0% ----- B 105 C 1.0 Min + 86.81 % B 140 C 2.0 Min + 68.08 % B 140 C 3.0 Min + 51.97 % 102 C 4.0 Min + 44.05 % 98 C 5.0 Min + 37.70 % 100 C 6.0 Min + 29.84 % 100 C 7.0 Min + 24.38 % 100 C 8.0 Min + 22.64 %  END 100 C 8.2 Min + 22.60 %	<i>The measurement is printed in the unit set for drying, provided the print rate function is switched on.  The individual values are separated by tabs in the "MODE PC".</i>
100-0% : + 22.60 % Residual weight : + 0.494 g  Stop : Autostop Duration : 8.2 Min	<i>Drying results are always output</i>
Last calibr. weight: 01.10.2018 Last calibr. temp. : 01.10.2018	<i>Date of last calibration, if this is switched on</i>
Operator : SAMPLE	<i>Operator ID, if this is switched on</i>

### 5.3.4 Configuring the application menu

<ul style="list-style-type: none"> <li>• SET APP. MENU</li> </ul>	METHOD-ID	ON/OFF
	TARGET WEIGHT	ON/OFF
	UNIT	ON/OFF
	PRINT RATE	ON/OFF
	STANDBY TEMP.	ON/OFF
	AUTOSTART	ON/OFF

The options activated under "SET APP. MENU" are enabled in the application menu and can be changed and set there (see chapter 5.4 "Application menu operation").

### 5.3.5 Balance calibration

• SET BALANCE CAL.		
MODE	OFF	<i>disabled</i>
	<b>EXTERNAL</b>	<i>external</i>
	EXT.-DEF.	<i>external with a freely defined weight (DEF. n.nnn g)</i>
DEF.	<b>0.0000 g</b>	<i>Calibration weight for the EXT. DEF. mode</i>

For details about calibrating the balance, see chapter 3.8 "Weight calibration" and see chapter 8.3.1 "Balance calibration".

### 5.3.6 Temperature calibration

• TEMP. CAL.		
TEMP. CAL.	ON/OFF	<i>Activate the temperature calibration</i>

See chapter 8.3.2 "Temperature calibration".

### 5.3.7 Stability

• STABILITY		
STABILITY	LOW	<i>Setting the stability controle</i>
	<b>MEDIUM</b>	
	HIGH	

### 5.3.8 Quick-start

• QUICK-START		
QUICK-START	ON/OFF	<i>Setting the start condition</i>

"QUICK-START OFF": The drying sequence starts as soon as a stable weighing value is reached.

## ■ 5 Operation

"QUICK-START ON": The drying sequence starts as soon as the «**START**» key is pressed, or the lid is closed. This enables more accurate moisture analysis of highly volatile samples.

### 5.3.9 Interface functions

• SET INTERFACE		
BAUDRATE	300	<i>Select the baud rate</i>
	<b>600</b>	
	1200	
	2400	
	4800	
	9600	
	19200	
	38400	
	57600	
PARITY	<b>7-EVEN-1STOP</b>	<i>Select the parity</i>
	7-ODD-1STOP	
	7-NO-2STOP	
	8-NO-1STOP	
	8-EVEN-1STOP	
	8-ODD-1STOP	
HANDSHAKE	<b>NO</b>	<i>Select the handshake function</i>
	XON-XOFF	
	HARDWARE	

The RS232/V24 interface on the instrument is matched to the interface of a peripheral instrument with the aid of the interface functions (see chapter 7 "Data transfer").

### 5.3.10 Date and time

• SET DATE AND TIME		
DATE	[DD.MM.YY]	<i>Set date and time</i>
TIME	[HH.MM.SS]	
FORMAT	<b>STANDARD/US</b>	

**NOTE**

If a power failure occurs, the timer keeps running. If this doesn't happen, this indicates that the instrument's backup battery has run out and has to be replaced by Precisa Customer Service.

**5.3.11 Password protection**

The two main menus and the drying parameters for the device can be protected against unwanted changes by using a freely selectable, four-digit password.

- If the password protection is deactivated, any operator can change the instrument settings.
- If "medium" password protection is activated, the configuration menu is protected against unwanted changes.
- If "high" password protection is activated, the configuration menu, the application menu and the drying parameters are protected.
- The disabled menu options and parameters can only be changed again by deactivating the password protection, i.e. by entering the correct password.

**NOTE**

**The password protection is deactivated in the factory settings.**

The **factory programmed password** can be found on our website at your dealer login. It is always valid, at the same time with your new selected password.







Keep a record of your **own password**.

**• PASSWORD**

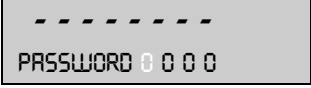
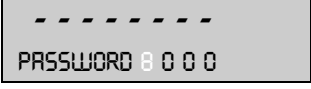
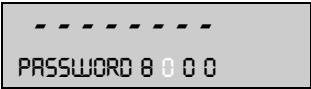
PASSWORD ----	DATA-PROTECTION	OFF	<i>No protection</i>
		MED	<i>The configuration menu is protected</i>
		HIGH	<i>The configuration and application menus, as well as the drying parameters are protected</i>
	NEW PASSWORD	----	<i>Enter a new password</i>

## ■ 5 Operation

Procedure for activating the password protection:

Display	Key	Step
	«↓»	Press repeatedly, until the "PASSWORD" is displayed.
	«←»	The first digit in the password flashes and can be changed.
	«↑» «↓»	Press repeatedly, until the first digit in the password is set.
	«→»	The second digit flashes. The password can now be entered fully.
	«←»	Confirm the password.
	«→»	The data-protection can now be set.
	«←»	The display flashes, and the data-protection can be activated.
	«↓»	Activate the data-protection.
	«←»	Confirm the data-protection.

Procedure for changing the password:

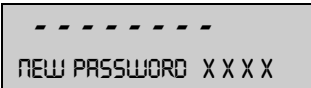
Display	Key	Step
	«↓»	Press repeatedly, until "NEW CODE" appears. Set the new code as described above.



### 5.3.12 Anti-theft encoding

The instrument can be protected against theft by using a freely selectable, four-digit numerical code:

- If the anti-theft code is deactivated, the instrument can be switched on again and operated after a power cutoff without having to enter a code.
- If the anti-theft code is activated, the instrument asks for the code to be input after each power cutoff.
- If the code is entered incorrectly, the instrument is blocked.
- If the instrument is blocked, it must first be disconnected from the power supply, then reconnected and unblocked by entering the correct code.
- After seven consecutive incorrect entries, the display reads "NO ACCESS, CALL SERVICE". In this case only a Precisa service engineer can unblock the instrument again.



#### NOTE

**The anti-theft encoding is deactivated in the factory settings.**

The **preprogrammed code** set in the factory is: **8 9 3 7**

This code is the same in all Precisa instruments. Therefore, for security reasons enter your own code.

Keep your **own code** in a safe place.

• THEFTCODE		
THEFTCODE ----	THEFT-PROTECTIONON/OFF	<i>Switch encoding on/off</i>
	NEW CODE ----	<i>Enter a new code</i>

In order to activate the anti-theft encoding, follow the same steps described for password protection.

### 5.3.13 Key tone

• KEY TONE	
KEY TONE	<b>ON/OFF</b> <i>Switch key tone on and off</i>

If switched on, a short tone sounds each time the button is pressed.

## ■ 5 Operation

### 5.4 Application menu operation

This section explains the structure of the application menu and its functions.

The structure of the application menu is dynamic and can be defined in the configuration menu (see chapter 5.3.4 "Configuring the application menu").

If a menu option is disabled in the configuration menu, it is not contained in the current application menu.

Main path	Definable functions
<b>METHOD</b>	<i>Enter the name of a method</i>
<b>SET TARGET WEIGHT</b>	<i>Definition of starting weight help</i>
<b>UNIT</b>	<i>Selection of the drying unit</i>
<b>PRINT RATE</b>	<i>Enter the interval time for the print rate Only if "PRINT RATE" is also set in printformat</i>
<b>STANDBY TEMP.</b>	<i>Definition of the standby temperature function</i>
<b>AUTOSTART</b>	<i>Definition of the autostart function</i>

- The settings programmed in the factory are depicted in **bold**.
- In order to aid clarity, the only part of the menu tree shown in each function description is the part which relates to the application in question.
- Explanations on the menu functions are depicted in *italics*.

#### 5.4.1 Activating the application menu

- Press «**MENU**» following the start-up process in order to get to the application menu.

#### 5.4.2 Methods

A changing in the method is automatically saved and is still available after a restart of the instrument. This method comprises the settings for the drying program and the starting weight.

The following data is saved for the method:

- Name of the method

- Drying program with:
  - Drying mode
  - Drying temperature
  - Stop time
  - Autostop
  - Autostart setting
  - Standby temperature
  - Unit for the result
- Starting weight with:
  - Nominal weight
  - Upper weight limit
  - Lower weight limit

If the moisture analyser is in weighing mode and the current starting weight is lower than the minimum sample weight ( $< 0.2$  g), the name of the method currently loaded is displayed in the info line.

The method and the settings can be printed by keeping the "PRINT" key pressed in until "PRINT APPLICATIONS" appears (see chapter 5.5.2 "The print key").

### 5.4.2.1 Setting method name

• METHOD		
METHOD	tt...	<i>Enter the name for the method</i>

### 5.4.3 Starting weight

• SET TARGET WEIGHT		
	WEIGHT CHECK ON/OFF	<i>Switch check on/off</i>
	NOMINAL 5.000 g	<i>Enter nominal weight</i>
	UPPER LIMIT 6.000 g	<i>Define upper limit</i>
	LOWER LIMIT 4.000 g	<i>Define lower limit</i>

With the aid of the «TARGET WEIGHT», you can weigh the sample exactly to check that it matches a defined reference value plus/minus permissible deviations.

## ■ 5 Operation

" + ", " - " and " →||← " are active in the display.

If " →||← " lights up, this indicates that the measurement lies within the defined tolerances, and the drying process can commence. If the sample weight lies outside the starting weight tolerance, the drying process cannot be activated. In this case the starting weight tolerances are displayed on the screen as an error message.

### 5.4.4 Units

• UNIT	
UNIT	100-0%
	0-100%
	ATRO 100-999%
	ATRO 0-999%
	G/KG
	RESIDUAL WEIGHT
	WEIGHT LOSS

The unit of the measurement results printed in the report can be selected in the "UNIT" menu option. The defined unit is also used to print out interim values. The unit of measurement for the printout can only be changed before, and not during, a measurement.

The unit selected is also used as the display unit, although it can also be adjusted during and after the measurement (see chapter 5.5.3 "The change key").

#### Description/calculation of the units

Explanation of the variables used

- MW: Moist weight (weight value at the start of the measurement)
- DW: Dry weight (weight value at the end of the measurement)

Unit	Calculation
Dry mass in percent:	$100 - 0\% = \frac{DW}{MW} \cdot 100\%$
Moisture in percent:	$0 - 100\% = -\frac{MW - DW}{MW} \cdot 100\%$
ATRO dry mass:	$ATRO\ 100 - 999\% = \frac{MW}{DW} \cdot 100\%$

Unit	Calculation
ATRO moisture:	$ATRO\ 0 - 999\% = -\frac{MW - DW}{DW} \cdot 100\%$
Residual weight in g / kg [%]:	$g / kg = \frac{DW}{MW} \cdot 1000$
Residual weight in g:	RESIDUAL WEIGHT = DW
Moisture in g:	WEIGHTLOSS = MW - DW

### Explanations for the ATRO units

The ATRO unit is required exclusively in the wood industry.

In practice, wood contains different amounts of water, which can change continuously. The water content affects the combustion performance of the wood and the heat value. The water evaporates during drying. When wood is stored in the open air, it reaches the so-called air-dried status (A.D.) of 15% to 20% water content. The moisture is completely removed from the wood by heating the wood to temperatures over 100°C. This condition is called absolutely dry (abs.dry).

The wood moisture (*ATRO*) is the amount of water contained in the wood, expressed in terms of the percentage of the mass of the water-free wood and is calculated from the difference between the fresh weight (*MW*) and the dry weight (*DW*).

### 5.4.5 Print rate

• PRINT RATE	
PRINT RATE	1.0 MIN <i>Print rate interval</i>

The interval at which interim results are printed is set at "PRINT RATE". The print interval can be set in 0.1 min increments from 0.1 - 10.0 min.

### 5.4.6 Standby temperature

• STANDBY TEMP.	
STANDBY TEMP.	ON/OFF <i>Switch standby temperature on/off</i>

## ■ 5 Operation

TEMPERATURE	40°C	<i>Temperature value, only if the standby temperature is switched on</i>
-------------	------	--------------------------------------------------------------------------

Adjusts the temperature in the sample chamber to the set temperature, provided the sample chamber is closed. The temperature range available is 30°C ... 100°C. A flashing circle in the display indicates the standby temperature is not reached, yet.

### 5.4.7 Autostart

• AUTOSTART	
AUTOSTART	ON/OFF

If autostart is switched on, the measurement is started as soon as the sample chamber is closed. This is provided that the moisture analyser is prepared for a new measurement.

## 5.5 Special operating keys

### 5.5.1 The tare key

- Ensure that there is no drying taking place, i.e. that the instrument is in weighing mode.
- **Activating taring**
  - Press «T» briefly.
  - A taring procedure is performed.
- **Activating calibration**
  - Keep «T» pressed until "BALANCE CALIBRATION" is displayed.
  - Release «T».
  - The balance carries out a calibration in accordance with the settings in the configuration menu and logs these in the form of a printout (see chapter 5.3.5 "Balance calibration" and see chapter 8.3.1 "Balance calibration")
- **Activating a temperature calibration**
  - Keep «T» pressed until "TEMP. CALIBRATION" is displayed.
  - Release «T».
  - The moisture analyser carries out a temperature calibration and logs it in the form of a printout (see chapter 5.3.6 "Temperature calibration" and see chapter 8.3.2 "Temperature calibration").
- **Activating a temperature test**
  - Keep «T» pressed until "TEST TEMPERATURE" is displayed.
  - Release «T».
  - The moisture analyser carries out a temperature test.



#### NOTE

The calibration functions are only active if they are switched on in the configuration menu. The temperature test is always active. A calibration functions or a test can be interrupted by pressing «ON/OFF».

## ■ 5 Operation

### 5.5.2 The print key

- Ensure that there is no drying taking place, i.e. that the instrument is in weighing mode.
- **Printing out an individual value or a report**
  - Press «**PRINT**» briefly.
  - The drying report is printed out. The report for the last measurement can be printed out at the start of a new drying procedure. Reports printed afterwards do not contain any interim results. It is otherwise identical to the drying report which is printed during the measurement. If no drying has been performed since the instrument was started up, the weight value is printed.
- **Printing out the statistics**
  - Keep «**PRINT**» pressed until "PRINT STATISTICS" is displayed
  - Release «**PRINT**»
  - Statistics are printed.
- **Printing the instrument settings**
  - Keep «**PRINT**» pressed until "PRINT STATUS" is displayed.
  - Release «**PRINT**». The instrument settings are printed.

Status : -----	<i>Status printout for the settings.</i>
Date 07.10.2018 Time 16:12:39 Name : XM 50 Heater : Halogen / 50Hz Software : C00-0000 P19 Serialno : 4100283	<i>Instrument identification</i>
Print : Printformat : Date and Time : on Balance-ID : on Method-ID : off Counter : on Dryer Setup : on Print rate : off Operator-ID : off Cal. Info : on Print rate : 1.0 Min Operator : SAMPLE Mode : Printer	<i>Report printout settings</i>
Calibration : Mode : external Defined weight : 0.0000 g	<i>Balance calibration settings</i>
Temp. cal. : off	<i>Temperature calibration settings</i>
Interface : Baudrate : 9600 Parity : 7-even-1stop Handshake : Hardware	<i>Interface settings</i>
Data-protection : off Theft-protection : off	<i>Security settings</i>
Key tone: on	<i>Key settings</i>





- **Printing the application settings**

- Keep «**PRINT**» pressed until "PRINT APPLICATIONS" is displayed.
- Release «**PRINT**».
- The application settings and all the settings for the methods currently saved are printed.

Applications : -----	<i>Printout of the application settings and methods.</i>
Dryer setup : Heat mode : Standard Time Boost : 3.0 Min Temperature : 105 C Timer stop : off Time : 10.0 Min Auto stop : Digit/Time Free : 2/20 D/s Autostart : off Standby Temp : off Temperature : 40 C Unit : 100-0%	<i>Current drying parameter settings</i>
Targe weight : Weight check : off Nominal : 5.000 g Upper limit : 6.000 g Lower limit : 4.000 g	<i>Current starting weight settings</i>

### 5.5.3 The change key

- **Changing units**

- If drying has already been performed or is under way, the unit of measurement displayed can be changed using the change key «». Once a drying procedure is ended, the drying result can be displayed in all the available units until the start of a new drying sequence using the change key «».
- Release «» once the unit to which you wish to change is displayed.

### 5.5.4 The start/stop key

- **Starting drying manually**

- Ensure that there is no drying taking place, i.e. that the instrument is in weighing mode.
- Press «**START/STOP**» briefly.
- The measurement is started.

- **Stopping drying manually**

- Drying is under way.
- Press «**START/STOP**» briefly.
- The measurement is stopped.

## ■ 5 Operation

- **Statistics Info**

- Keep «**START/STOP**» pressed until "STATISTICS INFO" is displayed.
- Release «**START/STOP**»

- **Reset Statistics**

- Keep «**START/STOP**» pressed until "RESET STATISTICS" is displayed.
- Release «**START/STOP**»

## 6 Determining moisture levels

The moisture analyser is used as a quick and reliable means of determining the moisture content in powders and liquids by the thermogravimetric process.

### 6.1 Fundamental principles

The term moisture does not just relate to water, it also encompasses all substances which evaporate when they are heated. Alongside water, they also include

- fats
- oils
- alcohol
- solvents
- etc...

There are different techniques for determining the moisture of a material.

Thermogravimetry is the technique used in the moisture analyser. In this technique, the sample is weighed before and after heating so as to determine the moisture content from the difference.

The conventional drying oven technique works on the same principle except that, the measurement takes much longer. In the drying oven technique, the sample is heated from the outside inwards by a stream of hot air so as to draw out the moisture.

In the case of the halogen radiation used in the moisture analyser, the radiation mainly penetrates into the sample where it is converted into heat energy, heating the sample from the inside out. A small portion of the halogen radiation is reflected by the sample; this reflection is lower in dark samples than in light samples. The penetration depth of the halogen radiation depends on the permeability of the sample. In the case of low-permeability samples, the halogen radiation only penetrates into the upper layers of the sample, which may lead to incomplete drying, charring or combustion. Consequently, the sample preparation is extremely important.

## ■ 6 Determining moisture levels

### 6.1.1 Adjusting to the existing measuring process

The moisture analyser is frequently used in place of other drying techniques (like the drying oven) because it is easier to operate and offers shorter measuring times. Consequently, the conventional measuring process has to be adapted to the device so that comparable results can be achieved.

- Performing a parallel measurement
  - Lower temperature setting in the moisture analyser than in the drying oven technique
- The result achieved with the moisture analyser does not match the reference
  - Repeat the measurement with a changed temperature setting
  - Vary the switch-off criterion
- Adapting with the calibration curve or factor

## 6.2 Sample preparation

Prepare one sample at a time for measurement. This prevents the sample exchanging moisture with the ambient surroundings. If a number of samples have to be taken simultaneously, they should be packed in air-tight containers so as to ensure that they do not change while they are in storage.

Distribute the sample **evenly** and **thinly** on the weighing pan in order to achieve reproducible results.

If it is applied unevenly, this causes an inhomogeneous distribution of heat in the sample being dried, resulting in incomplete drying or an extension to the measuring time. If the sample is piled up, it heats up with greater intensity in the upper layers, causing combustion or encrustation to occur. The high layer thickness or possible formation of a crust prevents the moisture from escaping from the sample. This residual moisture means that measurement results achieved this way are not verifiable and reproducible.

### Solids:



- Distribute powder samples evenly on the weighing pan.
- Make coarse samples smaller using a mortar or grinder. Do not expose the sample to any heat while you are grinding it as this will lead to a loss of moisture.

### Liquids:

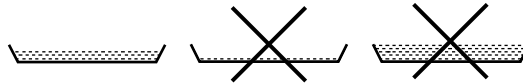

- You are advised to use a fiber glass filter for liquids, pastes or slurry samples. The fiber glass filter offers the following advantages:
  - even distribution on account of the capillary effect
  - no formation of drops
  - quick evaporation due to the larger surface

### 6.2.1 Preventing samples being encrusted

In order to avoid the sample becoming encrusted, solvent can also be added to the sample after the measurement has started. The solvent added has no bearing on the final result of the measurement.

- Start the measurement, automatically or by pressing the «**START/STOP**» key.
- The moisture analyser hood can be opened again within 5 seconds of the start. During this time, the words "START DRYING" are displayed in the info line of the display.
- After opening the sample chamber, you can add additional solvent at any time until the hood is closed. Once the moisture analyser hood is closed, the measurement is continued. "START COVER CLOSE" appears in the info line in the display. If you press the «**START/STOP**» key, the measurement is interrupted.

## ■ 6 Determining moisture levels



### NOTE

The additional solvent is taken into account in the measurement printout because all the interim values are calculated on the basis of the current weight value.

However, it has no bearing on the drying result because the solvent has completely dried off.

## 6.3 Setting drying parameters

The drying parameter setting procedure is started with the four function keys under the display.



Each of the four function keys starts the entry of the corresponding drying parameter. The parameters are entered or changed in the same way as the menu operation procedure (see chapter 5.1 "Menu control operation principle"), except that only the current parameter can be changed each time.

### 6.3.1 Heating program



This function key is used to start the heating program selection.

There are three heating programs available for determining the moisture content:

- Standard drying
- Boost drying
- Soft drying

• HEATING PROGRAM		
BOOST TIME	3.00 MIN	<i>Only if Boost is selected</i>
HEAT MODE	<b>STANDARD</b> BOOST SOFT	<i>Select heating program</i>

### Standard drying

The drying temperature is predefined by the user. The end temperature is started up with a high heat output and is kept constant with slight overshooting.

This program is used for most samples.

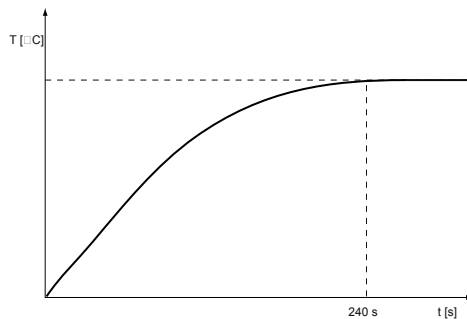

### Boost drying

The drying temperature is predefined by the user. During the first minutes of drying, the target temperature is exceeded by 40%. The time is selectable between 0.1 - 99.9 min. Once this time has elapsed, the temperature is adjusted down to the target temperature. The temperature is started up with a high heat output.

The maximum temperature reached during the boost is the highest definable temperature of the moisture analyser.

## ■ 6 Determining moisture levels

This program is used for samples with a very high moisture content.

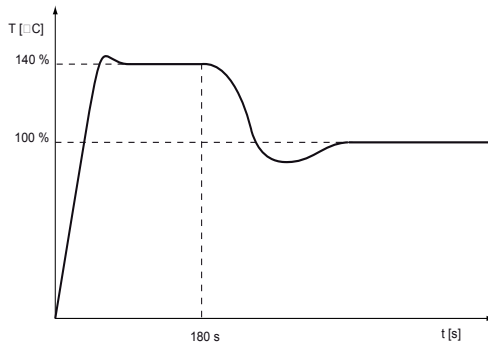

### Soft drying

The drying temperature is predefined by the user. The end temperature is started up gently with a low heat output. The end temperature is reached after approx. 4 minutes.

This program is used for samples with a low moisture content in which there is a risk of combustion.

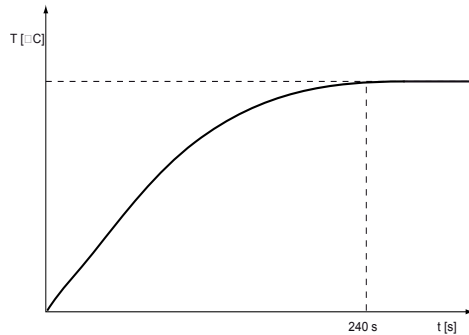



### 6.3.2 Temperature

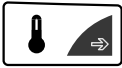

This function key is used to start the drying temperature input.

The drying temperature can be entered in 1 °C increments from 30 °C - 170 °C.

<b>• DRYING TEMPERATURE</b>		
TEMPERATURE	105 °C	<i>Temperature input</i>

The temperature setting for drying with the moisture analyser can be selected lower than than for drying with the oven drying method.

### 6.3.3 Timer stop



This function key is used to define the drying time.

If the timer stop is switched on, the measurement procedure is ended once the time set has elapsed.

The time can be set in 0.1 min increments from 0.1 - 240.0 min.

<b>• DRYING TIME</b>		
STOP TIME	10.0 MIN	<i>Only if the timer stop is switched on</i>
TIMER STOP	ON/OFF	

### 6.3.4 Switch-off criteria

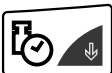

This function key is used to start the definition of the switch-off criteria for the measurement.

A freely definable stop mode is available according to the "digit per time" principle. There is also the automatic stop mode "ADAPT-

## ■ 6 Determining moisture levels

STOP".

• STOPMODE		
DIGIT/TIME	2/20	<i>Only if Digit/Time is selected</i>
AUTO STOP	OFF	
	<b>DIGIT/TIME</b>	
	<b>ADAPTSTOP</b>	

### End-point condition Digit per time

The drying procedure ends as soon as the reduction in weight, during the time set, is smaller than the number of digits set. The reduction in weight must have been greater than the end-point condition at some point.

In the freely definable mode, the user can set from 1 - 99 digits in 1 digit increments and from 10 - 90 seconds in 10 second increments.

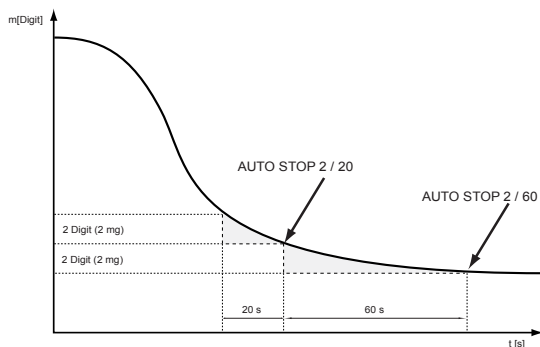

One digit is the smallest change in measurement that can be displayed by the moisture analyser.

In the XM 50: 1 digit = 1 mg

### ADAPTSTOP

Is a fully automatic stop mode which determines the switch-off time on the basis of the drying progress.

## 6.4 Statistics

All results are automatically taken into the statistical evaluation.

- Insure that there is no drying taking place, i.e. that the instrument is in weighing mode.
- Keep «**START/STOP**» pressed until "STATISTICS INFO" is displayed
- Release «**START/STOP**»
- Change between the statistical values with «↓» resp.«↑».

• STATISTICS INFO	
MEAN	<i>Mean</i>
MAX	<i>Maximum</i>
MIN	<i>Minimum</i>
STDDEV	<i>Standard deviation</i>
STDDEV %	<i>Relative standard deviation</i>
1 =	<i>Value 1</i>
2 =	<i>Value 2 etc.</i>

### 6.4.1 Print statistics

Exit statistics with «**esc**»

- Keep «**PRINT**» pressed until "PRINT STATISTICS" is displayed.
- Release «**PRINT**».

The statistics are printed:

***** Precisa XM 50 ***** -----	<i>Protocol title, printed only in the mode Printer.</i>
Date 07.10.2018 Time 11:06:01	<i>Date and time if set</i>
Name : XM 50 Heater : Halogen / 50Hz Software : C00-0000 P19 Serialno : 4100283	<i>Balance-ID if set</i>
Method : 105 Date : 07.10.2018 Samples : 4 Unit : 100-0%	
Mean : 57.36 % Maximum : 57.39 % Minimum : 57.34 % Stddev : 0.02 % Stddev % : 0.042 %	<i>Statistics</i>
1 : 57.34 % 2 : 57.38 % 3 : 57.34 % 4 : 57.39 %	<i>Recorded values</i>

## ■ 6 Determining moisture levels

Last calibr. weight : 01.10.2018  
Last calibr. temp. : 01.10.2018

*Information on calibration*

---

### 6.4.2 Reset statistics

The statistic are reseted by

- restarting the device
- changing the method
- the statistics are manually reseted:  
reset statistics
  - Keep «**START/STOP**» pressed until "RESET STATISTICS" is displayed.
  - Release «**START/STOP**».

## 7 Data transfer

The moisture analyser is equipped with an RS232/V24 interface for data transfers to peripheral instruments.

Before the data transfer, the RS232 interface must be matched with the one in the peripheral instrument in the instrument's configuration menu (see chapter 5.3.9 "Interface functions").

- **Handshake**

The handshake is set in the factory to "NO". It can be set to software handshake XON/XOFF or to hardware handshake.

- **Baud rate**

Possible baud rates: 300, 600, 1200, 2400, 4800, 9600, 19200, 38400 or 57600 baud.

- **Parity**

Possible parity: 7-even-1 stop, 7-odd-1 stop, 7-no-2 stop or 8-no-1 stop, 8 even 1 stop or 8 odd 1 stop.

Pos.	0	1	2	3	4	5	6	7	8	9	10
7-even-1	SB	1.DA	2.DA	3.DA	4.DA	5.DA	6.DA	7.DA	PB	SP	-
7-odd-1	SB	1.DA	2.DA	3.DA	4.DA	5.DA	6.DA	7.DA	PB	SP	-
7-no-2	SB	1.DA	2.DA	3.DA	4.DA	5.DA	6.DA	7.DA	1.SP	2.SP	-
8-no-1	SB	1.DA	2.DA	3.DA	4.DA	5.DA	6.DA	7.DA	8.DA	SP	-
8-even-1	SB	1.DA	2.DA	3.DA	4.DA	5.DA	6.DA	7.DA	8.DA	PB	SP
8-odd-1	SB	1.DA	2.DA	3.DA	4.DA	5.DA	6.DA	7.DA	8.DA	PB	SP

SB: Start bit                      PB: Parity bit

DA: Data bit                      SP: Stop bit

- **Display**

S	D7	D6	D5	D4	D3	D2	D1	D0	U	U	U
---	----	----	----	----	----	----	----	----	---	---	---

Data transfer takes place in ASCII code:

1	2	3	4	5	6	7	8	9	10	11	12	13	14	15	...	...	...
B	B	B	S	D7	D6	D5	D4	D3	D2	D1	DP	D0	B	U	...	CR	LF

B                      Blank (space)

## ■ 7 Data transfer

S	Prefix (+, -, space)
DP	Decimal point
D0...D7	Digits
U ...	Unit (only if the weight is stable, otherwise no unit is sent)
CR	Carriage return
LF	Line feed



### NOTE

Unused positions are filled with spaces.

The decimal point DP can be between D0 and D7.

## 7.1 Connection scheme

### • Standard duplex connection

moisture analyser	RJ 45	D25 / D9	Peripheral instrument
RS 232 out	2	→ 3 / 2	RS 232 in
RS 232 in	6	← 2 / 3	RS 232 out
GND	5	→ 7 / 5	GND

### • Standard duplex connection with additional hardware handshake in the peripheral instrument

moisture analyser	RJ 45	D25 / D9	Peripheral instrument
RS 232 out	2	→ 3 / 2	RS 232 in
RS 232 in	6	← 2 / 3	RS 232 out
GND	5	→ 7 / 5	GND
CTS	3	← 20 / 4	DTR
DTR	7	→ 5 / 8	CTS

• Pin configuration of the RJ45 socket

moisture analyser	RJ 45	Remark
n.c.	1	Not connected
RS 232 out	2	Out (V24)
CTS	3	In (V24)
VDC	4	Out (9 ... 16V)
GND	5	0V
RS 232 in	6	In (V24)
DTR	7	Out (V24)
EXTBUS	8	In (5V, logic)

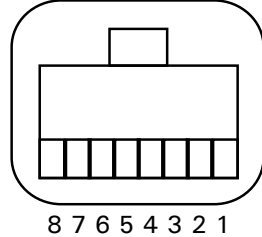

## 7.2 Remote control commands

Command	Function
ACKn	Acknowledge n=0 off; n= 1 on
CAL	Start calibration (only if EXT is selected)
DN	Reset weight display
D.....	Describe weight display (right-aligned)
@N	Reset info display
@.....	Describe info display
N	Reset instrument
OFF	Switch off instrument
ON	Switch on instrument
PCxxxx	Enter anti-theft code
PDT	Print date and time
PRT	Start printing (Press «PRINT» key)
PST	Start print status
Pn (t.t.t)	Set print mode n = 0 Individually print each value (unstable) n = 1 Individually print a stable value (stable) n = 2 Print after change of load n = 3 Print after each integration period n = 4 Print with time basis in s (t.t.t)

## ■ 7 Data transfer

Command	Function
SDTttmmjj hhmmss	Set date and time (German: (Tag, Monat, Jahr, Stunde, Minute, Sekunde))
SDTmmddy hhmmss	Set date and time (Month, Day, Year, Hour, Minutes, Seconds)
T (ttt)	Tare or set tare to a specific value
ZERO	Set instrument to 0 (if weight is stable and within the zero setting range)
Rttt	Adjusts the heating to the required temperature (30°C - 170°C)
ROFF	Switch off heating
PWT (ttt.t)	Print weight value and temperature value Print with time basis in s (ttt.t) (switch off by transmitting PWT)

### 7.2.1 Examples of the remote control of the instrument



#### NOTE

Each remote control command must terminate with «CR» «LF». The commands are acknowledged if required.

Input	Description of the function activated
D - - - - -	Five dashes are displayed
DTEST123	tESt123 is displayed
D	The display is dark
T10	-10.000 g (Tare set to = 10 g)
T1	-1.000 g (Tare set to = 1g)
T	Instrument is tared
R100	Adjusts the temperature to 100 °C



## 8 Service

### 8.1 Maintenance and servicing

The moisture analyser must be treated carefully and cleaned regularly. This is a precision instrument.



#### **DANGER**

To facilitate maintenance work, the instrument must be disconnected from the power supply. Also ensure that the instrument cannot be reconnected to the power supply during the work by anyone else.

Take care during cleaning that no liquid gets into the instrument. If you spill any liquid onto the instrument, unplug it from the electrical supply immediately. Do not operate the moisture analyser again until you have had it checked by a Precisa service engineer.

The connection ports on the back of the instrument may not come into contact with liquids.

Regularly dismantle the weighing pan and the weighing pan holder and remove any dirt or dust from under the weighing pan and on the balance housing with a soft brush or a soft, lint-free cloth, moistened with a mild soap solution.

The balance pan and the holder can be cleaned under running water. Take care to ensure that both parts are completely dry before they are re-installed on the balance.



#### **CAUTION**

Never use solvents, acids, alkalis, paint thinners, scouring powders or other aggressive or corrosive chemicals for cleaning since these substances attack the surfaces of the instrument housing and can cause damage.

Regular maintenance of the moisture analyser by your Precisa service agent will guarantee unrestricted functioning and reliability over many years and will extend the lifespan of the instrument.

## 8.2 Replacing the mains fuse

If the display remains dark after you switch on the instrument, this generally means that the instrument's fuse is faulty and has to be changed.

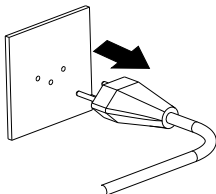

**DANGER**

Unplug the instrument from the mains before replacing the fuses.

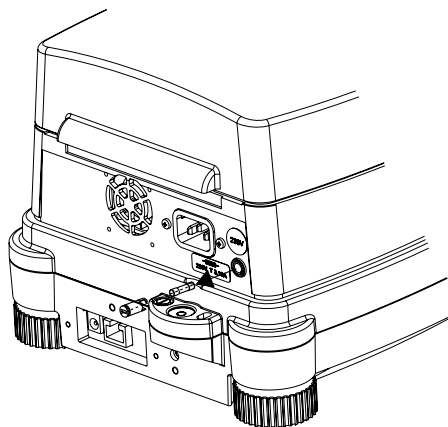

- Screw open the fuse holder on the back of the instrument using a screwdriver, screwing anticlockwise.
- Replace the faulty fuse:
  - 230 volt variant:  
**T 3.15 A, 230 V, 5x20 mm**
  - 115 volt variant:  
**T 6.3 A, 115 V, 5x20 mm**
- If the instrument still does not work after replacing the fuse, contact the Precisa Service Center.



**DANGER**

Under no circumstances should you use other fuses or attempt to bridge the fuse.

## 8.3 Calibration

The calibration of the moisture analyser is defined in the configuration menu (see chapter 3.8 "Weight calibration" and see chapter 5.3.5 "Balance calibration").



### NOTE

The balance calibration and the temperature calibration can be interrupted at any time by pressing «ON/OFF».

### 8.3.1 Balance calibration

Possible types of balance calibration:

- External calibration by means of ICM (Intelligent Calibration Mode)
- External calibration with a freely definable weight

#### External calibration by means of ICM

Calibration weights in increments of 10g can be used for the moisture analyser whereby the calibration weights must correspond to the precision of the instrument.

"SET CALIBRATION MODE EXTERNAL" must be set in the configuration menu (see chapter 5.3.5 "Balance calibration") for external calibration by means of ICM.

Display	Key	Step
		<i>The balance is in Weighing mode.</i>
	«T»	<i>Press until "BALANCE CALIBRATION" appears.</i>
		<i>The balance carries out a Zero measurement "0000 g" is shown flashing).</i>
		<i>After the zero measurement the display flashes with the recommended calibration weight.</i>

## ■ 8 Service

Display	Key	Step
		<i>Place the calibration weight on the weighing pan. The display continuous to flash.</i>
		<i>Calibration is complete when the display stops flashing</i>

### External calibration with a freely definable weight

"SET CALIBRATION MODE EXT.-DEF." must be set in the configuration menu (see chapter 5.3.5 "Balance calibration") for external calibration with a freely definable weight.

You then need to enter the effective value of the calibration weight (DEF. n,nnnn g) with up to ten times the precision of the instrument balance.

	<b>NOTE</b>
Is calibrated with the free weight, so only this weight may be used.	

Procedure to follow:

Display	Key	Step
		<i>The balance is in Weighing mode.</i>
	«T»	<i>Press until "BALANCE CALIBRATION" appears.</i>
		<i>The balance carries out a Zero measurement "0000 g" is shown flashing).</i>
		<i>After the zero measurement the display flashes with the previously entered calibration weight.</i>

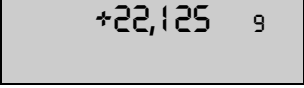
Display	Key	Step
		<i>Place the calibration weight on the weighing pan. The display continues to flash.</i>
		<i>Calibration is complete when the display stops flashing</i>

### Calibration report printout



Calibration -----	Balance calibration report
Date 16.10.2018 Time 12:51:36 Name : XM 50 Heater : Halogen / 50Hz Software : C00-0000 P19 Serialno : 4100283	Time of the calibration and instrument data
Calibration o.k.	Status of the calibration
Operator :	Operator ID, if activated under Set Print Format (see chapter 5.3.3 "Configuring the report printout").

## 8.3.2 Temperature calibration

The temperature calibration is used to adjust the temperature measuring system of the moisture analyser to a known reference temperature measuring instrument.

In order to enable a temperature calibration to take place, "TEMP. CAL." must be switched on in the configuration menu (see chapter 5.3.6 "Temperature calibration").

The temperature sensor must be inserted in the sample chamber. Close the cover and follow the procedure:

Display	Key	Step
		<i>The balance is in Weighing mode.</i>
	«T»	<i>Press until "TEMP. CALIBRATION" appears.</i>

## ■ 8 Service

### Display

```

-----
T100 T160      START
  
```

### Key

«←»

### Step

Set the lower calibration value.

```

-----
T100 T160      START
  
```

«→»

Set the higher calibration value.

Note: The difference between the two temperature-values must be bigger than 40°C.

```

-----
T100 T160      START
  
```

«START»

Start the calibration

```

-----
TEMP. 25C      35.00MIN
  
```

The moisture analyser heats up to the first temperature.

The temperature and the time remaining for the temperature calibration are displayed in the info line.

```

-----
TEMP. 100°C
  
```

After 35min., enter the temperature that is measured by the external thermometer.

```

-----
TEMP. 101°C      35.00MIN
  
```

The moisture analyser heats up to the second temperature.

The temperature and the time remaining for the temperature calibration are displayed in the info line.

```

-----
TEMP. 160°C
  
```

After 35min., enter the temperature that is measured by the external thermometer.

Once the temperature calibration has ended, the report is printed.

### Temperature calibration report printout

```

Temperature Calibration
-----
Date 16.10.2018   Time 12:51:36
Name              : XM 50
Heater            : Halogen / 50Hz
Software          : C00-0000 P19
Serialno         : 4100283
  
```

### Temperature calibration report

Time of the calibration and instrument data

Temp. Reference ID : ...	Identifier of the temperature adjustment set
Temperature 100 C : 101 C Temperature 160 C : 161 C	Values of the temperature adjustment
Temperature Calibration o.k. Temperature 101 C : 101 C Temperature 161 C : 161 C	Instrument has been correctly temperature-calibrated
Operator :	Operator ID, if activated under Set Print Format (see chapter 5.3.3 "Configuring the report printout").

### 8.3.3 Temperature test

The temperature test is used to verify the temperature measuring system of the moisture analyser to a known reference temperature measuring instrument.

The temperature sensor must be inserted in the sample chamber.

Close the cover and follow the procedure:

Display	Key	Step
		<i>The balance is in Weighing mode.</i>
	«T»	<i>Press until "TEST TEMPERATURE" appears.</i>
	«←»	<i>Set the lower test value.</i>
	«⇒»	<i>Set the higher test value.</i>
	«START»	<i>Start the test</i>

Note: The difference between the two temperature-values must be bigger than 40°C.

## ■ 8 Service

### Display

```

-----
TEMP. 25C      35.00MIN.
  
```

The temperature and the time remaining for the temperature test are displayed in the info line.

```

-----
TEMP. 100°C
  
```

### Step

*The moisture analyser heats up to the first temperature.*

*After 35min., enter the temperature that is measured by the external thermometer.*

```

-----
TEMP. 102°C    35.00MIN.
  
```

*The moisture analyser heats up to the second temperature.*

The temperature and the time remaining for the temperature test are displayed in the info line.

```

-----
TEMP. 160°C
  
```

*After 35min., enter the temperature that is measured by the external thermometer.*

Once the temperature test has ended, the report is printed.

### Temperature test report printout

Test Temperature -----	Temperature test report
Date 16.10.2018 Time 12:51:36 Name : XM 50 Heater : Halogen / 50Hz Software : C00-0000 P19 Serialno : 4100283	Time of the test and instrument data
Temp. Reference ID : ...	Identifier of the temperature test set
Temperature 100 C : 101 C Temperature 160 C : 161 C	Values of the temperature test
Operator :	Operator ID, if activated under Set Print Format (see chapter 5.3.3 "Configuring the report printout").

## 8.4 Firmware update

In order to update the firmware, you need to download the Universal Download Tool from our website and install it onto a PC with Windows.



The firmware for the balance can also be downloaded from the Downloads area on the website. This can then be loaded into the instrument with the aid of the Universal Download Tool.

## 8.5 Error messages

The instrument displays an error description in the info line.

 <b>NOTE</b>
If an error occurs without any corresponding description in the info line, a Precisa service engineer must be called.

Error message	Cause
Starting value too small	<ul style="list-style-type: none"> <li>• The sample weight is too small (&lt;0.200 g). The sample weight must be greater than 0.200 g.</li> </ul>
LOWER LIMIT x.xxx g UPPER LIMIT x.xxx g	<ul style="list-style-type: none"> <li>• The sample weight does not lie within the tolerance for the starting weight.</li> </ul>

### 8.5.1 Notes on correcting faults

Faults and their possible causes should be listed in the following table. If you cannot clear the fault on the basis of the table, please contact a Precisa service engineer.

Fault	Possible causes
Weight display does not light up	<ul style="list-style-type: none"> <li>• Instrument is not switched on</li> <li>• Mains cord is not plugged in</li> <li>• Mains fuse is faulty</li> </ul>
"OL" is displayed	<ul style="list-style-type: none"> <li>• The weight range has been exceeded (observe the information on the maximum weight range)</li> </ul>
"UL" is displayed	<ul style="list-style-type: none"> <li>• The weight range is below the range of the instrument (weighing pan or pan holder missing)</li> </ul>

## ■ 8 Service

Fault	Possible causes
The weight display changes continuously	<ul style="list-style-type: none"> <li>• The draft is too strong at the location of the instrument</li> <li>• The instrument support is vibrating or fluctuating</li> <li>• The weighing pan is touching a foreign body</li> <li>• The sample is absorbing moisture</li> <li>• The sample is evaporating/vaporising/subliming</li> <li>• Sharp changes in temperature in the sample</li> </ul>
Results of weighing are clearly incorrect	<ul style="list-style-type: none"> <li>• The instrument has not been correctly tared</li> <li>• The instrument has not been correctly levelled</li> <li>• The calibration is no longer correct</li> <li>• Sharp temperature fluctuations occur</li> </ul>
Configuration menu cannot be changed	<ul style="list-style-type: none"> <li>• The password lock is activated in the configuration menu</li> </ul>
The display flashes continuously during calibration	<ul style="list-style-type: none"> <li>• The instrument location is not quiet enough (interrupt calibration with «<b>ON/OFF</b>» and move the balance to a better location).</li> <li>• Use of a calibration weight which is too imprecise (only applies to external calibration)</li> </ul>
The connected printer won't work	<ul style="list-style-type: none"> <li>• The printer is not switched on</li> <li>• The data cable is faulty or not connected</li> <li>• The interface settings do not match the moisture analyser</li> </ul>
The printer prints incorrect characters	<ul style="list-style-type: none"> <li>• The parity setting or the baud rate of the interface don't match</li> <li>• The data cable is faulty</li> </ul>
Drying won't start	<ul style="list-style-type: none"> <li>• The sample is not stable</li> </ul>

# 9 Overview

## 9.1 Technical data

Spezification	XM 50
Heat source, heater type	Halogen / Infra-red / Dark Radiator
Weighing range [g] / Readability [g]	52 / 0.001
<b>Drying:</b>	
Readability [%]	0.01
Reproducibility in approx. 1g [%]	0.5
Reproducibility in approx. 10g [%]	0.05
Sample weight [g]	0.2 - 52
Result calculations:	100-0%, 0-100% ATRO 100-999%, ATRO 0-999%, G/KG, RESIDUAL, LOSS
<b>Heating:</b>	
Temperature range [°C] / Increment [°C]	30 - 170 / 1
Heating methods	Standard, Boost, Soft
Intervals	Boost + 1
Booster	+ 40% during n.n min (0.1 - 99.9)
<b>Switch-off criteria:</b>	
Autostop [d/s]	freely definable 1 - 99 / 10 - 90
Adapstop	x
Timer stop [min.]	0.1 - 240.0
<b>Monitoring:</b>	
Viewing window	x
Audio	x
<b>Printout:</b>	
GLP	x
Printout - Interval [min.]	0.1 - 10.0
Sample numbering	x
<b>Memory capacity:</b>	
Methods (with all settings)	1
User texts	2
<b>Operation:</b>	
"Easy access" sample holder	x
Display	VFD
Keypad	10 keys

## ■ 9 Overview

<b>Spezifikation</b>	<b>XM 50</b>
Password protection	x
<b>Special features:</b>	
Initial weighing with limits and guide	x / x
Software download and update	x
<b>Calibration:</b>	
Balance	with a test weight
Temperature	at 100°C and 160°C, selectable
<b>Miscellaneous:</b>	
Timer for date and time	x
Interface for PCs and printers	RS232
PrecisaBus	x
Anti-theft protection	Code and mechanically
<b>Connection:</b>	
Mains voltage	230V or 115V Can be switched by changing the unit of heat (may only be done by Precisa Service)
Mains frequency [Hz]	50 - 60
Power consumption [W]	450
<b>Dimensions:</b>	
Instrument housing (WxHxD) [mm]	218x177x340
Weight [kg]	4.3

## 9.2 Accessories

<b>Accessories</b>	<b>Article number</b>
Multiplexer for up to 7 Precisa instruments (RS232)	350-8513
Data cable RJ 45 - RJ 45, 0.75 m	350-8525
Data cable RJ 45 - RJ 45, 1.5 m	350-8520
Data cable RJ 45 - RJ 45, 3.0 m	350-8521
Data cable RJ 45 - DB9 female (PC), 1.5 m	350-8557
Data cable RJ 45 - DB25 male (printer), 1.5 m	350-8559
Dust cover over display, 5 pieces	350-8590
Aluminium pans, 80 pieces	350-2032
Stainless steel dish, reusable (1 pcs.)	330-2018
Fiber glass filters, 80 pieces	350-4130
Printer LP4024, with cable and paper roll	350-8391
Paper roll for Printer LP4024, 4 pcs	350-8392
Ribbon for Printer LP4024	PN 3953-013
Temperature sensor plate (Sensor - type K)	350-8580
Temperature calibration set (Sensor - type K) with certificate	350-8585
Temperature calibration set (Sensor - type K) without certificate	350-8584
Dust filter complete	350-8687
50 g adjustment weight	350-8241

## ■ 9 Overview

### 9.3 Menu

#### 9.3.1 Configuration menu tree

«MENU» Key is pressed during switch-on:

<b>• SET DATA PRINT</b>																															
	<table border="1"> <tbody> <tr> <td>SET PRINTFORMAT</td> <td>DATE AND TIME</td> <td>ON/OFF</td> </tr> <tr> <td></td> <td>BALANCE-ID</td> <td>ON/OFF</td> </tr> <tr> <td></td> <td>METHOD-ID</td> <td>ON/OFF</td> </tr> <tr> <td></td> <td>COUNTER</td> <td>ON/OFF</td> </tr> <tr> <td></td> <td>DRYER SETUP</td> <td>ON/OFF</td> </tr> <tr> <td></td> <td>PRINT RATE</td> <td>ON/OFF</td> </tr> <tr> <td></td> <td>OPERATOR-ID</td> <td>ON/OFF</td> </tr> <tr> <td></td> <td>CAL. INFO</td> <td>ON/OFF</td> </tr> <tr> <td></td> <td>PRINT RATE</td> <td>1.0 MIN</td> </tr> <tr> <td></td> <td>OPERATOR</td> <td>ttt...</td> </tr> </tbody> </table>	SET PRINTFORMAT	DATE AND TIME	ON/OFF		BALANCE-ID	ON/OFF		METHOD-ID	ON/OFF		COUNTER	ON/OFF		DRYER SETUP	ON/OFF		PRINT RATE	ON/OFF		OPERATOR-ID	ON/OFF		CAL. INFO	ON/OFF		PRINT RATE	1.0 MIN		OPERATOR	ttt...
	SET PRINTFORMAT	DATE AND TIME	ON/OFF																												
		BALANCE-ID	ON/OFF																												
		METHOD-ID	ON/OFF																												
	COUNTER	ON/OFF																													
	DRYER SETUP	ON/OFF																													
	PRINT RATE	ON/OFF																													
	OPERATOR-ID	ON/OFF																													
	CAL. INFO	ON/OFF																													
	PRINT RATE	1.0 MIN																													
	OPERATOR	ttt...																													
MODE	PRINTER PC																														
<b>• SET APP. MENU</b>																															
	METHOD-ID	ON/OFF																													
	TARGET WEIGHT	ON/OFF																													
	UNIT	ON/OFF																													
	PRINT RATE	ON/OFF																													
	STANDBY TEMP.	ON/OFF																													
	AUTOSTART	ON/OFF																													
<b>• SET BALANCE CAL.</b>																															
	MODE	OFF EXTERNAL EXT.-DEF.																													
	DEF.	0.0000 g																													
<b>• TEMP. CAL.</b>																															
TEMP. CAL. ON/OFF																															
<b>• STABILITY</b>																															
STABILITY	LOW MEDIUM HIGH																														

• **QUICK-START**

QUICK-START ON/OFF

• **SET INTERFACE**

	BAUDRATE	300 600 1200 2400 4800 <b>9600</b> 19200 38400 57600
	PARITY	<b>7-EVEN-1STOP</b> 7-ODD-1STOP 7-NO-2STOP 8-NO-1STOP 8-EVEN-1STOP 8-ODD-1STOP
	HANDSHAKE	<b>NO</b> XON-XOFF HARDWARE

• **SET DATE AND TIME**

	DATE	[DD.MM.YY]
	TIME	[HH.MM.SS]
	FORMAT	<b>STANDARD/US</b>

• **PASSWORD**

PASSWORD	----	DATA-PROTECTION	<b>OFF</b> MED HIGH
		NEW PASSWORD	- - - -

• **THEFTCODE**

THEFTCODE	----	THEFT-PROTECTION	<b>ON</b> <b>OFF</b>
		NEW CODE	- - - -

• **KEY TONE**

KEY TONE **ON/OFF**

## ■ 9 Overview

• LANGUAGE	
LANGUAGE	ENGLISH
SPRACHE	DEUTSCH
LANGUE	FRANCAISE

### 9.3.2 Application menu tree



«MENU» Key is pressed during operation:

• METHOD	
METHOD	ttt...
• SET TARGET WEIGHT	
WEIGHT CHECK	ON/OFF
NOMINAL	5.000 g
UPPER LIMIT	6.000 g
LOWER LIMIT	4.000 g
• UNIT	
UNIT	100-0%
	0-100%
	ATRO 100-999%
	ATRO 0-999%
	G/KG
	RESIDUAL WEIGHT
	WEIGHT LOSS
• PRINT RATE	
PRINT RATE	1.0 MIN
• STANDBY TEMP.	
STANDBY TEMP.	ON/OFF
TEMPERATURE	40 °C
• AUTOSTART	
AUTOSTART	ON/OFF

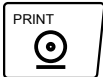

### 9.3.3 Key menus

Hold the appropriate key down until the required menu option appears in the info line.

	<ul style="list-style-type: none"> <li>• <b>Start/Stop key</b></li> <li>START/STOP DRYING</li> <li>STATISTICS INFO</li> <li>RESET STATISTICS</li> </ul>	<p><i>not displayed</i></p>
	<ul style="list-style-type: none"> <li>• <b>Print key</b></li> <li>PRINT</li> <li>PRINT STATISTICS</li> <li>PRINT STATUS</li> <li>PRINT APPLICATIONS</li> </ul>	<p><i>not displayed</i></p>
	<ul style="list-style-type: none"> <li>• <b>Tare key</b></li> <li>TARE</li> <li>BALANCE CALIBRATION</li> <li>TEMP. CALIBRATION</li> <li>TEST TEMPERATURE</li> </ul>	<p><i>not displayed</i></p>
	<ul style="list-style-type: none"> <li>• <b>Change key</b></li> <li>100-0%</li> <li>0-100%</li> <li>ATRO 100-999%</li> <li>ATRO 0-999%</li> <li>G/KG</li> <li>RESIDUAL WEIGHT</li> <li>WEIGHT LOSS</li> <li>BALANCE WEIGHT</li> </ul>	

## ■ 9 Overview

### 9.3.4 Setting drying parameters

	<b>• HEATING PROGRAM</b>
	BOOST TIME      3.00 MIN HEAT MODE <b>STANDARD</b> BOOST SOFT

	<b>• DRYING TEMPERATURE</b>
	TEMPERATURE      105°C

	<b>• DRYING Time</b>
	STOP TIME      10.0 MIN TIMER STOP      ON/OFF

	<b>• STOPMODE</b>
	DIGIT/TIME      2/20 AUTO STOP      OFF <b>DIGIT/TIME</b> ADAPTSTOP

### 9.3.5 Setting and saving the configuration

«MENU» and «T» keys are pressed during switch-on

<b>FACTORY CONFIG.</b>	Load factory-configuration.
<b>USER CONFIG.</b>	Load user-configuration.
<b>STORE CONFIG.</b>	Store present configuration as user-configuration.



## 9.4 Index

### A

Accessories 67  
ADAPTSTOP 48  
Adjusting to the existing measuring process 42  
Anti-theft code 31  
Application menu 21, 32  
Application menu, activating 32  
Application menu, configuring 26  
Application, printing 39  
ATRO units 35  
Autostart 36

### B

Balance calibration 57  
Baud rate 51  
Boost drying 45

### C

Calibration 57  
Calibration test, Temperature 37  
Calibration, Balance 17, 37, 57  
Calibration, Temperature 37, 59  
Cleaning 55  
Configuration menu 21  
Configuration menu, activating 24  
Configuration, printing 38  
Configuration, save, store, factory 23  
Connection scheme 52

### D

Data transfer 51  
Date and Time 28  
Drying parameters 44  
Drying, start 39  
Drying, stop 39

### E

Encrusting of samples 43  
Error messages 63  
External calibration 57  
External calibration, def. weight 58

### F

Factory configuration 23  
Fibre glass filter 43  
Finishing drying 39  
Fundamental principles 41

### H

Handshake 51  
Heating program 44

### I

ICM 57

### K

Key sound 31

### L

Levelling 16  
Location 14

## **M**

Mains connection 15  
Maintenance 55  
Method, content 32  
Method, printing 39

## **P**

Parity 51  
Password protection 29  
Print key 38

## **R**

Recall method 32  
Remote control commands 53  
Replacing the mains fuse 56  
Report, printing 38  
RJ45 socket 53

## **S**

Safety instructions 9  
Safety measures 16  
Sample preparation 42  
Scope of delivery 13  
Service 55  
Servicing 55  
Socket RJ45 53  
Soft drying 46  
Standard drying 45  
Standby temperature 35  
Standby temperature, enabling 26  
Starting drying 39  
Starting Weight 33  
Statistics, Reset 40  
Storage 12  
Switch-off criteria 47  
Switch-off criterion digit/time

48

Switch-off, setting 47

## **T**

Tare key 37  
Target Weight 33  
Target Weight, enabling 26  
Taring 37  
Technical data 65  
Temperature calibration 27, 59  
Temperature, setting 47  
Time and Date 28  
Timer stop, setting 47  
Transport 12  
Troubleshooting 63

## **U**

Units 34  
Units, calculation 34  
Units, change 39  
Unpacking 11