

MINUTES OF THE MEETING OF THE RECREATION, LEISURE & OPEN SPACES COMMITTEE

Held on Wednesday 1st March 2023 at 7.00pm in the Forest Suite, The Gateway, Ringwood

PRESENT: Cllr Andy Briers (Chairman)
Cllr Darren Loose (Deputy Chair)
Cllr Philip Day
Cllr Gareth Deboos
Cllr Hilary Edge
Cllr Rae Frederick
Cllr John Haywood
Cllr Peter Kelleher
Cllr Gloria O'Reilly
Cllr Glenys Turner

IN ATTENDANCE: Chris Wilkins, Town Clerk
Nicola Vodden, Office Manager
Cllr Jeremy Heron

OS/6232 PUBLIC PARTICIPATION

There were two members of the public present for an item on the agenda.

A young resident addressed the Committee about his proposal to install a skate ramp feature at North Poulner play area. He explained how sometimes Carvers is too far to travel to when he and his friends only have a short amount of time available. It is sometimes too big and can get crowded. There is space for the feature and people could come to use it.

He answered some questions posed by Members relating to expected usage, the neighbourhood and the cost. It was explained a concrete version would be quieter and long lasting, but more expensive, compared to wood or metal which would be less expensive, but noisier and would need replacing sooner.

The Committee thanked him for attending and bringing the matter to its' attention.

OS/6233 APOLOGIES FOR ABSENCE

All members were present.

OS/6234 DECLARATIONS OF INTEREST

There were none.

OS/6235 MINUTES OF THE PREVIOUS MEETING

RESOLVED: That the minutes of the meeting held on 1st February 2023, having been circulated, be approved and signed as a correct record.



With the agreement of Members, agenda item 6. Was brought forward for the benefit of the members of the public present.

OS/6236

SKATE RAMP AT NORTH POULNER PLAY AREA

Members referred to representation made during the public participation at the start of the meeting and considered the Town Clerk's report (*Annex A*). He added that costs of a wooden construction would be in the region of £1,000 - £1,500.

A discussion followed on how this could be funded, if agreed, and some concerns were raised in relation to potential issues for residents in the area. There is no budget, so funding would need to be from a reserve, unallocated CIL receipts, grants or possible sponsorship. It was also suggested the Council could perhaps match any money secured from fundraising.

There is considered to be a lack of amenity in Poulner and this would be a good use of the site and an enhancement to the recently added football goals. Also, if the wooden version was considered, should there be any issues, the matter could be re-evaluated and the ramp removed if necessary.

RESOLVED: 1) That the installation of a quarter-pipe ramp be approved in principle; and
2) That officers investigate funding options available.

ACTION C Wilkins

OS/6237

EVENTS MANAGEMENT

Cllr Frederick reported on the Events Management sub-committee meeting which took place on 28th February 2023 (*Annex B*).

She provided details on the Coronation event 'Gathering on the Green' which is being planned for Sunday 7th May between 12 noon and 5pm. There will be a funfair, bouncy castles, food outlets and crafts stalls. She had drafted a letter to businesses regarding sponsorship of the event. The team will meet on-site to determine the extent of the funfair and the location of the steam train.

It has been decided to hold the event on the Bickerley, as to hold it elsewhere would have increased the costs of the event significantly, with hiring of tables and chairs and additional security requirements for road closures. It was noted the guidance from Buckingham Palace encourages community events where people can eat lunch together on parks or village greens.

RESOLVED: That the update on events be noted.

OS/6238

REVIEW OF CEMETERY REGULATIONS AND FEES

Members considered the Town Clerk's report (*Annex C*) and the issues for decision therein. He added, in relation to the Cemetery regulations, that not a lot had changed, but they had been re-written to arrange the rules more logically, group similar regulations together, remove outdated section and provided clarification or additional information where required. The design sizes for memorials had been added to the regulations and removed from the fees table. Local funeral director and memorial masons had been consulted and there had been no comments received in relation to the regulations.

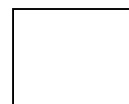

In response to a question about the columbarium project, The Town Clerk explained that he was awaiting a full specification to progress the procurement exercise and he expected this would be this calendar year. Regulation of the columbarium will be different in that the niches will be leased and conditions will be set out in the lease. Proposals will be brought before the Committee along with fees, in due course.

A review of the cemetery fees was agreed in principle at a previous meeting, where it was suggested burden of the fees should be shifted to reflect more the work required. A rebalanced set of fees was provided in Annex 4 to the report. In terms of a 'package' of exclusive rights, interment and memorial, the fees would increase by around the same as the rate of inflation. The only comment received from those consulted was in relation to the additional inscription fee and it was suggested this be the same for parishioners and non-parishioners. Members discussed this point and agreed to vary the proposed fee for non-parishioner from £180 to £90.

- RESOLVED:** 1) That the revised Cemetery Regulations be approved;
2) That the proposed new table of Cemetery Fees be approved save for the 'Each inscription after the first' fee where the non-parishioner fee is to be amended from £180 to £90 (*Annex 4 to the report – as amended*); and
3) That both the revised Cemetery Regulations and new table of Cemetery Fees take effect from 1st April 2023.

ACTION C Wilkins

**OS/6239
PROJECTS (current and proposed)**

RLOS8 Ringwood Youth Club – The meeting planned for 22nd February was inquorate and has been re-scheduled for 29th March. The papers will be issued shortly.

RLOS19 Carvers Strategic Development – Carvers Working Party will meet on 3rd March to discuss the masterplan.

RESOLVED: That the update in relation to projects (*Annex D*) be noted.

There being no further business, the Chairman closed the meeting at 7.48pm.

Note: The text in the Action Boxes above does not form part of these minutes.

RECEIVED
29th March 2023

APPROVED
5th April 2023

TOWN MAYOR

COMMITTEE CHAIRMAN



RECREATION, LEISURE & OPEN SPACES COMMITTEE

1st March 2023

Request for a skate ramp at North Poulner Play Area

1. Introduction and reason for report

- 1.1 A member of the public has asked that the Council install a 'quarter-pipe' skate ramp at North Poulner Play Area (the full request is set out below).

2. Background information and options

- 2.1 North Poulner Play Area is leased to the Council by New Forest District Council subject to a covenant to use it "only in accordance with the provisions of section 19(2) of the Local Government (Miscellaneous Provisions) Act 1976 for the purpose of recreational use". Section 19(1) empowers local authorities to provide such recreational facilities as they see fit (including both indoor and outdoor sports and play facilities) and section 19(2) reads "A local authority may make any facilities provided by it in pursuance of the preceding subsection available for use by such persons as the authority thinks fit either without charge or on payment of such charges as the authority thinks fit." This Council therefore has the power to grant the request, if members so decide.
- 2.2 Local councils must exercise their functions with due regard to their likely effect, if any, on crime and disorder (including anti-social and other behaviour adversely affecting the local environment), the misuse of drugs, alcohol and other substances and re-offending in their area and the need to prevent them.
- 2.3 The site currently includes a 'kicking-wall' and a separate goal (but no net) installed recently pursuant to the decision taken at this committee's meeting on 6th July 2022 (see minute ref. OS/6180). Officers recall that there was once a playground on this site with climbing frame, slide and monkey bars, with sand/wood chip underneath. There were complaints of noise, bad language, drinking and antisocial behaviour at that time. The grounds maintenance staff used frequently to find broken glass in the sand and litter everywhere.
- 2.4 Members will also recall that in 2020 officers installed a surplus bench at the site and this generated numerous objections from local residents, seemingly because it attracted youths to the site. The bench was subsequently stolen and has never been recovered.
- 2.5 A 'quarter pipe' is a fairly simple, stand-alone ramp structure (see Figure 1 below) which has various uses for skate-board, scooter and bmx-type bike users. Those made from wood and metal are cheaper than those made from concrete but less robust and more noisy. Nevertheless they are preferred by most users because their slight flexibility makes them more forgiving.
- 2.6 There is no provision for this in the current budget but one could be funded from reserves or, perhaps, by public appeal?

3. Issues for decision and any recommendations

Issues for decision:

- 3.1 Whether to approve the installation of a quarter-pipe ramp in principle; and**
3.2 (if approved) how to fund such installation.

For further information, contact:

Christopher Wilkins, Town Clerk
Direct Dial: 01425 484720
Email: chris.wilkins@ringwood.gov.uk



Figure 1 - Image of quarter pipe ramp

Request received by email:

“Dear Sir/Madam,

I am writing to you today to request a small skate feature to be constructed on the tarmacked surface on the public field between the Poulner School sports field and the Kingfisher Estate. The feature I am requesting is a 4 foot tall quarter pipe approximately 6-8 feet long with a small landing deck on the back.

There are many benefits from constructing a feature like this. These include:

- Improving health and well-being of users and reducing social exclusion and anti-social behavior.
- Attracting young people, and improving the quality of life for those within our community.
- Skateparks build and sustain healthy communities. As a gathering place for dedicated, athletic young and older people, a small skate feature would provide a forum for beginners and skilled skaters to meet and share experiences.
- Building a skate quarter pipe would also improve mental health because children, teens and adults would have a closer, more accessible way to exercise, learn a new skill and socialise with others
- A small quarter pipe would not make the area significantly different to what is already in place.

I do understand that the construction of a quarter pipe could bring some disadvantages to the local community. Some drawbacks of such a feature include:

- The cost of the feature must be considered but would not be very high at this scale.
- Inexperienced skaters using public skate features can sometimes be put in harm's way. But if a sign was put up saying that it is not recommended for inexperienced riders to ride the feature then this should help.
- It could be considered that skate parks could attract groups of youths and antisocial behavior. However, the site is not accessible from a through road and is also overlooked by residential properties which would act as a deterrent to antisocial behavior.

I would be very pleased and excited to discuss the development of this idea with you further and understand what permissions and funding would be needed to progress such a project.

Yours Sincerely,

[Name redacted]

Age 13

Events Management Sub-Committee

Notes of meeting held on Tuesday 28nd February 2023 at 3pm on Zoom

Present: Cllr Rae Frederick (Chair)
Cllr Jeremy Heron
Cllr Philip Day
Cllr Andy Briers

In attendance:
Charmaine Bennett, Events Manager
Sam Bracher – Meeting Administrator

1. Apologies for Absence

No Apologies

2. Declarations of interest

No interests were declared.

3. Minutes of the previous meeting – 24th January 2023

RESOLVED: That the minutes of the meeting held on 24th January 2023 having been circulated, be approved, and signed as a correct record.

4. Gathering on the Green – Ringwood Celebrates the Coronation of the King

The event manager went through the event planning document for the “Gathering on the Green” event which was circulated to sub-committee members on Tuesday 21st February. She wants everyone on the committee to be fully briefed on the event details and actions leading up to the event.

The stewarding arrangements for the day were discussed.

The sub-committee members agreed that as part of the security package we would book four security Stewards that are also first aid trained, to offer additional support.

She confirmed that the Ringwood and Fordingbridge Lions have agreed to offer support with stewarding the Mini Steam Train attraction, as they successfully did this at the Christmas event.

Churches Together will supply volunteers to steward and manage ques in the bouncy castle zone.

The Carnival will provide people to help with set up and clean up.

The event manager confirmed that the fun fair operator has confirmed they will bring a substantial fair between Friday and Monday of the event weekend.

It has been confirmed that Economy Van Hire - Ringwood will lend the event a Luton Van to help with storage on site. This would be in lieu of sponsorship.

The event sub-committee agreed that they would like to commission Ringwood TV to produce a film documenting the event as they felt this added value and put Ringwood on the map.

It was agreed that a promotional event advert was not needed to be purchased in the local Viewpoint Magazine.

It was confirmed that the town would be decorated with flags rather than bunting. Suggested date of 27th April for putting this up and sub-committee members asked to make a note of this date to assist.

A discussion took place regarding Ringwood Town Council providing a prosecco bar at the event to add profit. It was agreed that this would be mentioned at the Leisure & Recreation committee meeting on Wednesday 1st March to see if any councillors were willing to volunteer to help run this bar. It was agreed that the arrangements for this bar would not impact on the event managers workload.

It was agreed that the event had enough family activities and the Street Bubble Workshop that the event manager was looking to book would not be needed.

- | | |
|----------|--|
| ACTIONS: | <ol style="list-style-type: none"> 1. Cllr Frederick to send out a sponsorship letter to local businesses asking for a contribution towards the running cost of the event. 2. The event manager to confirm to the group if she was available for a sub-committee site visit on the afternoon of Saturday 4th March, time TBC. 3. The event manager to organise a site visit with the fair operator, mini steam train operator and the company that provide the stage, within the next two weeks. 4. The event manager to obtain a quote from the insurance company to see what the insurance premium would be for event attendance numbers exceeding 2000 people. Looking at between 2000 and 3000 people. 5. Cllr Heron to investigate what generators we need at the event. Tasked to speak to Kelvin in the grounds team to see if we have capacity to use the Town Council generators, and liaise with Adam Skirton who is providing the bouncy castles and the stage company to check their requirements 6. The event manager to speak with a representative from The Men's Shed to see what support they can offer at the event. 7. Cllr Day to liaise with the Fair Operator alongside Cllr Frederick with regards to space available and the fees required. They will meet separately to discuss further before arranging a meeting with the operator. 8. The event manager to prepare a letter to the residents around the Bickerley offering further details on the event. Cllr Frederick to help deliver these. 9. Cllr Frederick to approach Richard Frampton and Phil Hoyle at the London Tavern to try and source stage performers. It was agreed that the budget may need to be increased to ensure that there are quality acts on the stage during the day. 10. Cllr Briers to purchase a site plan of The Bickerley from Promap. Boundaries to include were discussed and agreed at the meeting. |
|----------|--|

5. Stall fees for Ringwood Grand Fireworks and Ringwood Winter Wanderland

Stall fees from “*Report A*” agreed by event sub-committee.

6. Wash up from Ringwood Grand Fireworks and Ringwood Winter Wanderland

“*Report B*” – Event Wash Up Notes were formally noted and agreed to be fed into future planning.

7. Loaning of reusable glasses

“*Report C*” detailing the proposed conditions for hiring out the Ringwood reusable glasses were discussed. The sub-committee agreed that they like the idea of sharing these glasses with other community groups and the suggested reimbursement fee of £1.25 for each glass not returned was acceptable and fair.

ACTIONS:	1. The event manager to follow up with The Ellingham and Ringwood Rugby Club who had approached her regards using the events at their festival.
----------	---

8. Future Agenda Items

It was agreed that the future agenda items would include:

- a.) First Aid Levels at the events in 2023
- b.) Event Management Plan for the Gathering on the Green Coronation event.

It was agreed that the Event Management Plan for this event should be submitted as a draft item asap with the final document ready for the end of March.

ACTIONS:	1. Cllr Day to look at the draft Event Management Plan to update with any new laws that could affect this event including the “Ask for Angela” initiative.
----------	--

No further business to discuss.

There being no further business, the meeting concluded at 16:13

The next Event Sub-Committee meeting – 28th March 2023

RECEIVED

APPROVED

RLOS COMMITTEE CHAIRMAN

SUB-COMMITTEE CHAIRMAN

RECREATION, LEISURE & OPEN SPACES COMMITTEE

1st March 2023

Review of Cemetery Regulations and Fees

1. Introduction and reason for report

- 1.1 Following the decision made at this committee's meeting in October last year (see minute ref. OS/6200) officers have reviewed the table of fees and taken the opportunity to re-write the Cemetery Regulations to conform. Members are invited to consider and, if thought, fit approve these changes.

2. Background information and options

- 2.1 The current Cemetery Regulations are attached as Annexe 1 and the suggested re-write as Annexe 2. The main aims of the re-write were:
- To re-arrange the regulations into a more logical order with rules on similar themes being grouped together;
 - To remove some redundant or out-dated rules, to clarify others and to add provision to cover some gaps that had become apparent; and
 - To codify fully the rules about the size and design of approved memorials, support these with illustrations and bring them fully into the Regulations and out of the fees table.
- 2.2 The current fees table is attached as Annexe 3 and the suggested new table as Annexe 4. The changes here reflect the decisions made last October.
- 2.3 Officers invited the local funeral director and the local memorial mason with whom they have most dealings to comment on the draft changes. The mason responded and Annexe 2 includes some suggested changes. The mason also asked if members would consider charging for approving additions or alterations to existing memorials at the rate for parishioners to non-parishioners as well (i.e. to stop applying the general 4x multiplier to that particular fee).
- 2.4 It is recommended that approved changes take effect on 1st April.

3. Issues for decision and any recommendations

Issues for decision:

- 3.1 Whether to approve the revised Cemetery Regulations; and**
3.2 Whether to approve the proposed new Table of Cemetery Fees.

For further information, contact:

Christopher Wilkins, Town Clerk
Direct Dial: 01425 484720
Email: chris.wilkins@ringwood.gov.uk



Ringwood Town Council

Ringwood Gateway, The Furlong, Ringwood, Hampshire, BH24 1AT

Tel: 01425 473883/484725

Email: town.council@ringwood.gov.uk

Website: www.ringwood.gov.uk

CEMETERY REGULATIONS

These Regulations became effective on 1st November 2019

1. A certain part of the Cemetery is consecrated for burials according to the Rites of the Established Church, the remaining part being unconsecrated and any burial may take place therein provided such burial and the service (if any) attending is/be conducted with decorum.
2. Notice of every interment on a form to be provided by the Council must be given at least 2 working days previous to such interment taking place to the Ringwood Town Council, Ringwood Gateway, The Furlong, Ringwood, Hampshire BH24 1AT between 09.00 and 16.30 hours on Mondays to Fridays inclusive. If interment is permitted in a vault or brick grave, then 3 clear days notice must be given. No notice can be received between 16.30 hours on a Friday and 09.00 hours on the following Monday.
3. **From the end of October to end of March**, the hours of interment will be between 09.00 and 1.30pm for graveside services, 09.00 and 2.30pm for a burial following a church service and 09.00 and 3pm for an ashes interment. **From the beginning of April to end of October** the hours of interment will be between 09.00 and 3.30pm for an interment of ashes and a burial following a church service and 09.00 and 3pm for a graveside service. No interment may take place on Saturdays, Sundays or Bank Holidays.
4. All fees and charges to be paid to the Ringwood Town Council when giving notice.
5.
 - a) Exclusive Rights of Burial will be granted on the original purchase for a period of thirty (30) years.
 - b) After the initial grant of an Exclusive Right of Burial, the Town Council will undertake to extend the grant (i) for whatever period is required to make the total period granted up to 30 years free of charge at any time and/or (ii) for periods of ten (10) years at a time during the final three (3) years of the term granted for the fee prevailing at that time.
 - c) Selection of the grave space in all cases both of general interment and on purchase is as determined by the Town Council.
 - d) All double depth graves for which the Exclusive Right of Burial has not been purchased at the time of the interment will be known as Common Graves and the Ringwood Town Council reserve the right to re-use these graves for future interments after a suitable period of time has elapsed.

- e) The Council reserves the right to charge fees at different rates depending on whether the applicant or other relevant person is a parishioner or not. For this purpose:
- i. a person who is or was ordinarily resident in the civil parish of Ringwood at the date of the application, or when they died, or at any time up to two years prior to their death shall be regarded as a parishioner.
 - ii. the rate applicable to parishioners shall be applied:
 1. where any application is made by more than one person, if any one of those persons is a parishioner;
 2. where an application concerns an interment, if either the applicant is or the person whose remains are to be interred was a parishioner;
 3. where an application relates to approval of a memorial, if either the applicant is or any of the persons named on the memorial was a parishioner;
 4. on an application to purchase Exclusive Right of Burial if either the applicant is or (if there is to be an immediate interment) the deceased was a parishioner; and
 5. on an application to register the transfer of an Exclusive Right of Burial only if the applicant is a parishioner.
 - iii. The Town Clerk and the Chairman of the Recreation, Leisure and Open Spaces Committee can exercise their discretion to treat any person as a parishioner in respect of the fees to be paid in any circumstances where they judge this to be fair and consistent with the Council's scheme of fees and charges.
- f) The option to purchase the Exclusive Right of Burial of a Common Grave is open to relatives at any time subsequent to the interment and must be exercised before a further interment has taken place in the same grave.
6. The certificate of the Registrar of Deaths, or where an Inquest has been held, of the Coroner, must be handed to the Town Clerk, or his duly appointed representative, before or at the same time of interment.
 7. Grave spaces for persons above 12 years of age shall be at least 6'6" (2400mm) x 4' (1200mm) and for those under 12 years of age at least 5' (1500mm) x 4' (1200mm).
 8.
 - a) The consent in writing of the owner (or funeral director on their behalf) to an interment in a purchased grave or vault must be given to the Town Clerk on the notice of burial and such consent must contain the grave number.
 - b) No interment shall take place in a new single depth grave unless the Exclusive Right of Burial for that grave is purchased at the time of the interment.
 - c) If the Exclusive Right of Burial has not been purchased, single depth graves will not be permitted, except where in the opinion of the Council ground conditions are unsuitable for deeper graves.
 9. Where any part of the Cemetery is set aside for the construction of vaults all such vaults shall be built by:
 - i) good whole bricks or stone properly bonded and solidly put together with good mortar compounded of good lime and clean sand or other suitable material or with good cement mixed with the clean sand or;
 - ii) other good hard or suitable material properly and solidly put together; and
 - iii) shall be subject to such premium charge as may be settled from time to time by the Town Council outside the normal scale of fees.
 10. Materials of every description to be used in the construction of graves or vaults and all stones, tombs, tablets and monuments must be conveyed into the Cemetery on vehicles with wheels not likely to cause damage to paths and the turf.



11. Whenever a burial has taken place, except in a private vault, the surface of the grave shall, as soon as practicable, be covered with soil and grass seed.
12. No body shall be buried in a grave so that any part of the coffin is at a depth of less than 3' (900mm) below the level of the ground adjoining the grave.
13. All damage caused to any boundary wall, fence, ground, paths, memorials or to any part of the Cemetery must forthwith be repaired to the satisfaction of the Town Clerk by the party causing the damage.
14. No body shall be buried in a grave unless the coffin is effectually separated from any other coffin already in that grave by the means of a layer of earth not less than 6" (150mm) in thickness.
15. Where any grave is re-opened for the purposes of making another interment therein, no person shall disturb any human remains interred therein or remove therefrom any soil which is offensive.
16. Every person who in a Cemetery buries a body in a vault shall on the day of the interment after the deposit in the vault of the coffin containing the body cause the coffin to be wholly or permanently imbedded in and covered with a layer or layers of good cement and concrete not less in any part of 6" (150mm) in thickness or to be wholly and permanently enclosed in a separate cell or receptacle which will be constructed of slate or stone flagging not less than 2" (50mm) in thickness properly jointed in cement or good brickwork in cement in such a manner as to prevent as far as may be practicable the escape of any noxious gas from the interior of the cell or receptacle.
17. The owner of an Exclusive Right of Burial shall maintain the grave in good order and condition to the satisfaction of the Town Clerk.
18. No memorial shall be erected upon any grave unless the Exclusive Right of Burial has been granted and without the consent in writing of the Town Clerk.
19. Before a memorial is erected, the correct grave must be verified and agreed with the Town Clerk.
20. The person responsible for erecting, fixing, moving or transporting the memorial must provide all necessary tools, equipment and labour necessary for that purpose.
21. The person responsible for erecting the memorial must move all spare soil and clean up after the completion of the work to the reasonable satisfaction of the Town Clerk.
22. Suitable foundations must be provided in order to prevent memorials from sinking and must be constructed in accordance with the Code of Working Practice issued by NAMM. All memorials must conform to British Standard 8415 for the Installation of Memorials.
23. No memorial, other than a headstone not exceeding 900mm (36") in height, 900mm (36") wide and 300mm in depth shall be permitted to be erected in any part of the Cemetery. Any flower vase or other container is to be an integral part of the memorial. Glass vases are not permitted.
24. No plants with roots shall be planted on or adjacent to graves without Town Council permission.
25. No ornaments or articles are to be placed on or adjacent to graves without Town Council permission.
26. Kerbstones are not permitted. Old kerbstones may be removed for maintenance, no new kerbs are allowed to replace old ones.



- 26A. Regulations 23, 25 and 26 above shall apply to [those] grave spaces for persons under 12 years of age [in any part of the Cemetery specifically laid out for such spaces] with the variation that ornaments, articles and kerbstones that would be prohibited elsewhere may be permitted with the permission and at the discretion of the Town Clerk.
27. No fencing of any type is allowed on or around graves.
28. The maximum height of a memorial in the Garden of Rest is 101mm (4" sloping to 2"), the size for a single plot being 550mm (22") x 275mm (11") and a double plot being 550mm (22") x 550mm (22").
29. In all cases, design dimensions and inscriptions must be submitted to the Town Clerk for approval whose decision shall be final. Any contemplated work not provided for as above will be the subject of arrangement and fees with the Council.
30. No memorial is to be removed for any purpose without the previous consent of the Town Clerk. Once consent has been granted the Town Council must be notified before any memorial is removed or replaced.
31. Artificial grass matting must be used in the case of all interments. No dogs will be allowed in any part of the Council's Cemetery unless on a leash. Cycling, riding of mopeds or motorcycles shall not be permitted within the Council's Cemetery other than in the Cemetery car park except funeral cars attending a funeral.
32. In all cases, whether the grave is hand dug or a mechanical digger is used, the Undertaker and any contractors appointed by him shall comply with all of the provisions contained within the latest Code of Practice issued by the Institute of Burial and Cremation Administration relating to grave digging. In particular, the Undertaker and any contractors shall be responsible for complying with all aspects of Health & Safety legislation relating to the digging, opening and backfilling of graves.
33. On completion of each funeral gravediggers are to remove all boards, wheelbarrows and equipment from the Cemetery.
34. A register of all burials will be kept in the Council office where at all times reasonable searches may be requested and certified extracts obtained from the Town Clerk upon payment of the appropriate fee.
35. The Council's Cemetery will be open to the public, free of any charge. As a result of an increase in the use of electric mobility scooters informal arrangements have been introduced to leave one bollard down each Thursday to allow access.
36. Visitors shall not interfere with the Council's employees in their duties nor employ them to plant graves or execute any private work whatsoever and employees are not authorised to receive any gratuity. Visitors will be required to keep to the paths and refrain from damaging shrubs, flowers and memorials and to behave in a decorous manner.
37. The Town Clerk's decision in respect of all matters of interpretation of these Regulations and all matters relating to the management of the Cemetery administered by the Ringwood Town Council shall be final.



**Ringwood
Town Council**

Cemetery Regulations

Contact details for Council office:

Address: Ringwood Gateway, The Furlong, Ringwood BH24 1AT

Telephone: 01425 473883

Email: town.council@ringwood.gov.uk

Website: www.ringwood.gov.uk

Version Control

C

Event	Description	Date
Initial adoption	Approval by Recreation, Leisure & Open Spaces Committee	



1. Introductory, fees and general

- 1.1 These Regulations are made by Ringwood Town Council as local burial authority for the civil parish of Ringwood pursuant to the Local Authorities' Cemeteries Order 1977 (SI 1977/204). They shall apply to the cemetery off Hightown Road, Ringwood including all additions to it that are managed by the Council from time to time as a burial ground ("the Cemetery"). They were adopted on [date] and became effective on [date].
- 1.2 Management of the Cemetery has been delegated by the Council to the Town Clerk. All applications, notices and correspondence relating to the Cemetery shall be addressed in the first instance to the Town Clerk at the Council office.
- 1.3 The Council will maintain such plans, registers and other records relating to the Cemetery as are required by law and will make these available for inspection by any person, at any time during the normal hours of opening of the Council's office, without charge. These records may be kept in electronic rather than physical form insofar as the law allows.
- 1.4 Fees shall be charged and payable for services at the Cemetery on the following terms:
 - 1.4.1 The Council will from time to time prescribe the chargeable services and the amount payable for each and publish these in the table of fees and charges available from the Council's office and published on its website;
 - 1.4.2 The Council reserves the right to charge fees at different rates depending on whether the applicant or other relevant person is a parishioner or not;
 - 1.4.3 Payment shall be made to the Council by any of the methods directed, from time to time, by the Town Clerk; and
 - 1.4.4 The relevant application or notice shall be deemed to take effect only once such payment has been received.
- 1.5 For the purposes of regulation 1.4.2 above:
 - 1.5.1 a person who is or was ordinarily resident in the civil parish of Ringwood at the date of the application, or when they died, or at any time up to two years prior to their death shall be regarded as a parishioner.
 - 1.5.2 the rate applicable to parishioners shall be applied:
 - 1.5.2.1 where an application is made by more than one person, if any one of those persons is a parishioner;
 - 1.5.2.2 where an application concerns an interment, if either the applicant is, or the person whose remains are to be interred was a parishioner;
 - 1.5.2.3 where an application relates to approval of a memorial, if either the applicant is or the deceased person named in the application was a parishioner;
 - 1.5.2.4 on an application to purchase Exclusive Right of Burial, if either the applicant is or (if there is to be an immediate interment) the deceased was a parishioner; and
 - 1.5.2.5 on an application to register the transfer of an Exclusive Right of Burial, if the applicant is a parishioner.



- 1.5.3 The Town Clerk may, after consulting the Chairman of the Recreation, Leisure and Open Spaces Committee, treat any person as a parishioner in respect of the fees to be paid in any circumstances where it is judged that this is fair and consistent with the Council's scheme of fees and charges (even if the conditions set out in regulation 1.5.2 above are not fully met).

2. Grave spaces and exclusive rights

2.1 The Town Clerk may:

2.1.1 Arrange for any part of the Cemetery to be consecrated for Christian burial according to the rites of the Church of England; or

2.1.2 Set apart for the use of a particular denomination or religious body any part of the Cemetery not so consecrated

PROVIDED THAT a sufficient part of the Cemetery remains unconsecrated and not set apart for the use of a particular denomination or religious body.

2.2 The Town Clerk may also designate any part or parts of the Cemetery for specific functions including the interment of the remains of children, the interment or scattering of cremated remains and the temporary storage above ground of cremated remains.

2.3 Every grave space shall be allocated a unique number and shall be identifiable from it on the plans and in the registers maintained by the Council. The Town Clerk shall designate additional grave spaces and allocate a suitable number to each one as the need arises.

2.4 Grave spaces for persons above 12 years of age shall be at least 6'6" (1981mm) x 4' (1219mm) and for those under 12 years of age at least 5' (1524mm) x 4' (1219mm).

2.5 The Council may grant Exclusive Right of Burial in any grave space in respect of which no prior grant (inconsistent with the proposed grant) is in effect at the time, subject to the following provisions:

2.5.1 The original grant shall be for a period of 30 years commencing on the date of the grant.

2.5.2 If Exclusive Right of Burial was granted for an original term that was less than 30 years, the Council will make a further grant to extend the original term to 30 years free of charge. If Exclusive Right of Burial was granted for an original term of 30 years or more, the Council will make a further grant in the final three years of the current term only and for such fee as is then prescribed.

2.5.3 Every Exclusive Right of Burial shall include the right to consent to each and any interment in and the right to determine the design of and the wording of any inscription upon any allowable memorial on the grave space.

2.5.4 Whilst the Council will make every reasonable effort to accommodate the preferences of applicants, the selection of grave spaces for the grant of Exclusive Right of Burial or for interment in a public grave shall be at the discretion of the Council.

- 2.5.5 In respect of public graves in which an interment has taken place, the Council reserves the right:
- 2.5.5.1 To re-use the graves for further interments; and
 - 2.5.5.2 To grant or to decline to grant Exclusive Right of Burial.
- 2.6 Where any part of the Cemetery is set aside for the construction of vaults, all such vaults shall be built by:
- 2.6.1 good whole bricks or stone properly bonded and solidly put together with good mortar compounded of good lime and clean sand or other suitable material or with good cement mixed with the clean sand or
 - 2.6.2 other good hard or suitable material properly and solidly put together; and
 - 2.6.3 shall be subject to such premium charge as may be settled from time to time by the Council outside the normal scale of fees.

3. Interments

- 3.1 A booking for any interment or disinterment shall be made at the Council office not less than 4 working days in advance. Written notice of every interment (on the form prescribed from time to time by the Council) must be given (to the Council at the Council office between 09.00 and 16.00 hours on Mondays to Fridays inclusive) at least 24 hours before such interment is booked to take place. No notice can be received between 16.00 hours on a Friday and 09.00 hours on the following Monday.
- 3.2 **Between the end of October and the end of March**, interments will be allowed between 09.00 and 13.30 hours for burials which include graveside services, 09.00 and 14.30 hours for burials which follow services held elsewhere and 09.00 and 15:00 hours for interments or scatterings of cremated remains. **Between the beginning of April and the end of October**, interments will be allowed between 09.00 and 15.00 hours for burials which include graveside services and 09.00 and 15.30 hours for burials which follow services held elsewhere and interments or scatterings of cremated remains. No interment may take place on a Saturday, Sunday or Bank Holiday.
- 3.3 Before any interment takes place the Certificate for Burial or Cremation issued by the Registrar of Births and Deaths (or the Coroner where an inquest has been held) or the Certificate of Cremation issued by the crematorium (as the case may be) must be delivered to the Town Clerk, or his duly appointed representative.
- 3.4 The consent in writing of the owner (or funeral director on their behalf) to an interment in a purchased grave or vault must be given to the Town Clerk on the notice of burial and such consent must contain the grave number.
- 3.5 The first interment in a public grave (other than a plot designated for interment of cremated remains only) shall be at double depth unless, in the opinion of the Council, ground conditions are suitable for single depth burial only.
- 3.6 No person shall dig any grave save with the permission of the Town Clerk after production of such evidence of current public liability insurance and a safe system of working as he shall reasonably require.
- 3.7 No body shall be buried in a grave so that any part of the coffin is at a depth of less than 3' (900mm) below the level of the ground adjoining the grave.

- 3.8 No body shall be buried in a grave unless the coffin is separated from any other coffin already in that grave by a layer of earth not less than 6" (150mm) in thickness.
- 3.9 Where any grave is re-opened for the purposes of making another interment therein, no person shall disturb any human remains interred therein or remove therefrom any soil which is offensive.
- 3.10 Every person who arranges an interment in a vault shall on the day of the interment (after the deposit in the vault of the coffin containing the body) cause the coffin to be wholly or permanently imbedded in and covered with a layer or layers of good cement and concrete not less in any part of 6" (150mm) in thickness or to be wholly and permanently enclosed in a separate cell or receptacle which will be constructed of slate or stone flagging not less than 2" (50mm) in thickness properly jointed in cement or good brickwork in cement in such a manner as to prevent as far as may be practicable the escape of any noxious gas from the interior of the cell or receptacle.
- 3.11 In all cases, whether the grave is hand dug or a mechanical digger is used, the Undertaker and any contractors appointed by him shall comply with all of the provisions contained within the latest Code of Burial Practice issued by the Federation of Burial and Cremation Authorities. In particular, the Undertaker and any contractors shall be responsible for complying with all aspects of Health & Safety legislation relating to the digging, opening and backfilling of graves.
- 3.12 On completion of each funeral gravediggers are to remove all boards, wheelbarrows and equipment from the Cemetery.

4. Memorials and memorabilia on graves

- 4.1 No memorial shall be erected upon any grave unless the Exclusive Right of Burial has been granted.
- 4.2 No person shall install, remove or carry out any work on a memorial unless and until they have produced to the Town Clerk such evidence of their membership of BRAMM or of current public liability insurance and a safe system of working as he shall reasonably require.
- 4.3 The person responsible for erecting, fixing, moving or transporting the memorial must:
 - 4.3.1 provide all necessary tools, equipment and labour necessary for that purpose; and
 - 4.3.2 clean up after the completion of the work to the reasonable satisfaction of the Town Clerk.
- 4.4 Suitable foundations must be provided in order to prevent memorials from sinking and must be constructed in accordance with the Code of Working Practice issued by NAMM and laid so the upper surface is level and flush with the surrounding ground. All memorials must conform to British Standard 8415 for the Installation of Memorials.
- 4.5 No memorial shall be permitted in any part of the Cemetery save as specified in Appendix 1 to the Regulations and all shall be subject to the following:

- 4.5.1 Any vase (other than an inscribed vase installed as an alternative to a headstone) shall be integrated within the permitted memorial and shall not be made of or include any glass.
- 4.5.2 Any permitted memorial may include (on the base or on the rear of the headstone adjacent to the base) the grave number and the name of the memorial mason in characters not exceeding 25mm (1") in height.
- 4.6 In all cases, design dimensions and inscriptions must be submitted for approval to the Town Clerk on the specified form, whose decision shall be final. Any contemplated work not provided for as above will be the subject of arrangement and fees with the Council.
- 4.7 No new kerbstones are permitted. Existing kerbstones may be retained or removed for repair or replacement with new elements of the same dimensions, shape, materials and colour as the existing. No other form of enclosing a grave space is permitted.
- 4.8 No plants with roots shall be planted on or adjacent to graves without Town Council permission.
- 4.9 No ornaments or articles (other than memorials of a permitted type for which specific approval has been given) are to be placed on or adjacent to graves without Town Council permission. The Council reserves the right to remove unauthorised memorabilia.
- 4.10 No memorial is to be removed for any purpose without the previous consent of the Town Clerk. Once consent has been granted the Town Council must be notified before any memorial is removed or replaced.
- 4.11 The Council reserves the rights
 - 4.11.1 to remove memorials and memorabilia from any grave in respect of which the period of grant of Exclusive Right of Burial has expired; and
 - 4.11.2 to remove or take other measures to make safe, at any time, any memorial or memorabilia if, in the reasonable opinion of the Council, it is in an unsafe condition.

5. Miscellaneous

- 5.1 The Council's Cemetery will be open to the public, free of any charge.
- 5.2 No dogs will be allowed in any part of the Cemetery unless on a leash.
- 5.3 No vehicle of any kind (other than wheel-chairs and mobility scooters) are allowed within the Cemetery other than in the Cemetery car park except funeral cars attending a funeral.
- 5.4 Materials of every description to be used in the construction of graves or vaults and all stones, tombs, tablets and monuments must be conveyed into the Cemetery on vehicles with wheels not likely to cause damage to paths and the turf.
- 5.5 Whenever a burial has taken place, except in a private vault, or a memorial has been installed, removed or altered, the surface of the grave shall, as soon as practicable, be covered with soil and grass seed.



- 5.6 All damage caused to any boundary wall, fence, ground, paths, memorials or to any part of the Cemetery must forthwith be repaired to the satisfaction of the Town Clerk by the party causing the damage.
- 5.7 The owner of an Exclusive Right of Burial shall maintain the grave in good order and condition to the satisfaction of the Town Clerk (unless such owner has entered into an agreement with the Council that it will undertake such maintenance). In all cases, the Council reserves the right to level the surface of grave spaces by adding or removing topsoil, grass-seed or turf as it shall deem expedient.
- 5.8 Visitors shall not interfere with the Council's employees in their duties nor employ them to plant graves or execute any private work whatsoever and employees are not authorised to receive any gratuity. Visitors will be required to keep to the paths and refrain from damaging shrubs, flowers and memorials and to behave in a decorous manner.
- 5.9 The Town Clerk's decision in respect of all matters of interpretation of these Regulations and all matters relating to the management of the Cemetery administered by the Ringwood Town Council shall be final.



**Ringwood
Town Council**

C

**Appendix 1 to
Cemetery Regulations**

Details of Permitted Memorials



1. The types of memorial permitted on the different types of grave within the cemetery are set out in the table below:

Standard grave for adult coffin burial	A headstone or a footstone plus a flat stone for additional inscriptions OR An inscribed vase.
Grave space designated for infant burial or for the interment of cremated remains (not being within a Garden of Rest) (includes Row T)	A headstone or a footstone OR An inscribed vase OR A flat or desk tablet
Grave space in the Old Garden of Rest	A flat tablet only
Grave space in the New Garden of Rest	A desk tablet only

2. Each memorial type is subject to a size restriction which is illustrated on the relevant drawing attached to and forming part of this Appendix 1. The tablet memorials permitted in the two gardens of rest are required to be of the respective size specified. Permitted memorials elsewhere shall not exceed the stated dimensions (but may be smaller, if desired). Where no size restriction on any permitted type of memorial or memorial feature is given, the Town Clerk may apply such restriction as deemed fit. The table of metric equivalents given below shall apply to the measurements stated.

Table of Metric Equivalents			
Imperial	Metric	Imperial	Metric
2"	50mm	18"	457mm
4"	101mm	20"	508mm
6"	152mm	22"	558mm
9"	228mm	24"	609mm
11"	279mm	26"	660mm
12"	304mm	28"	711mm
14½"	368mm	32"	812mm
15"	381mm	36"	914mm
17½"	444mm		

ADULT COFFIN BURIAL PLOTS

C

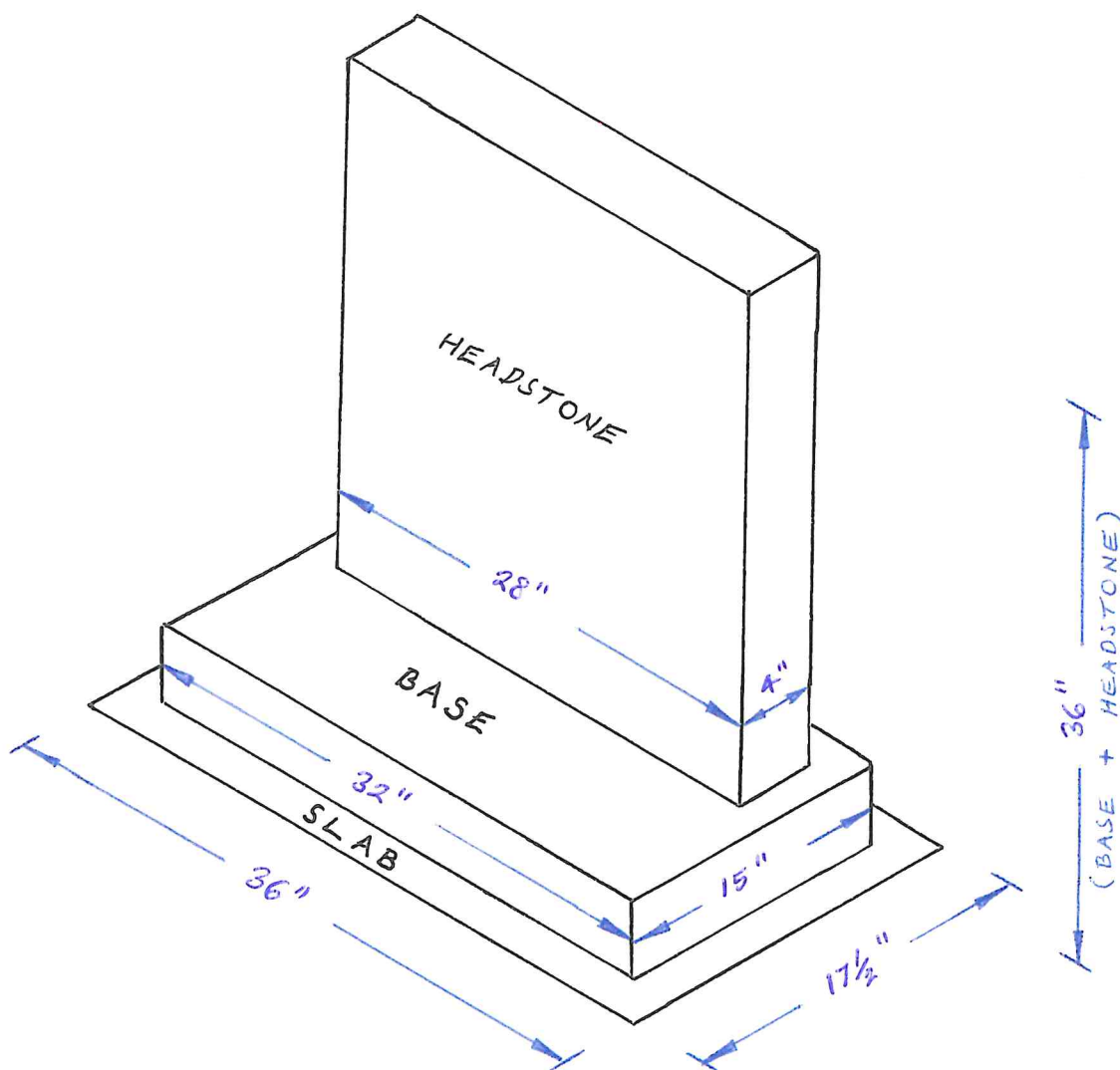

INFANT BURIAL AND ROW T ASHES PLOTS

C

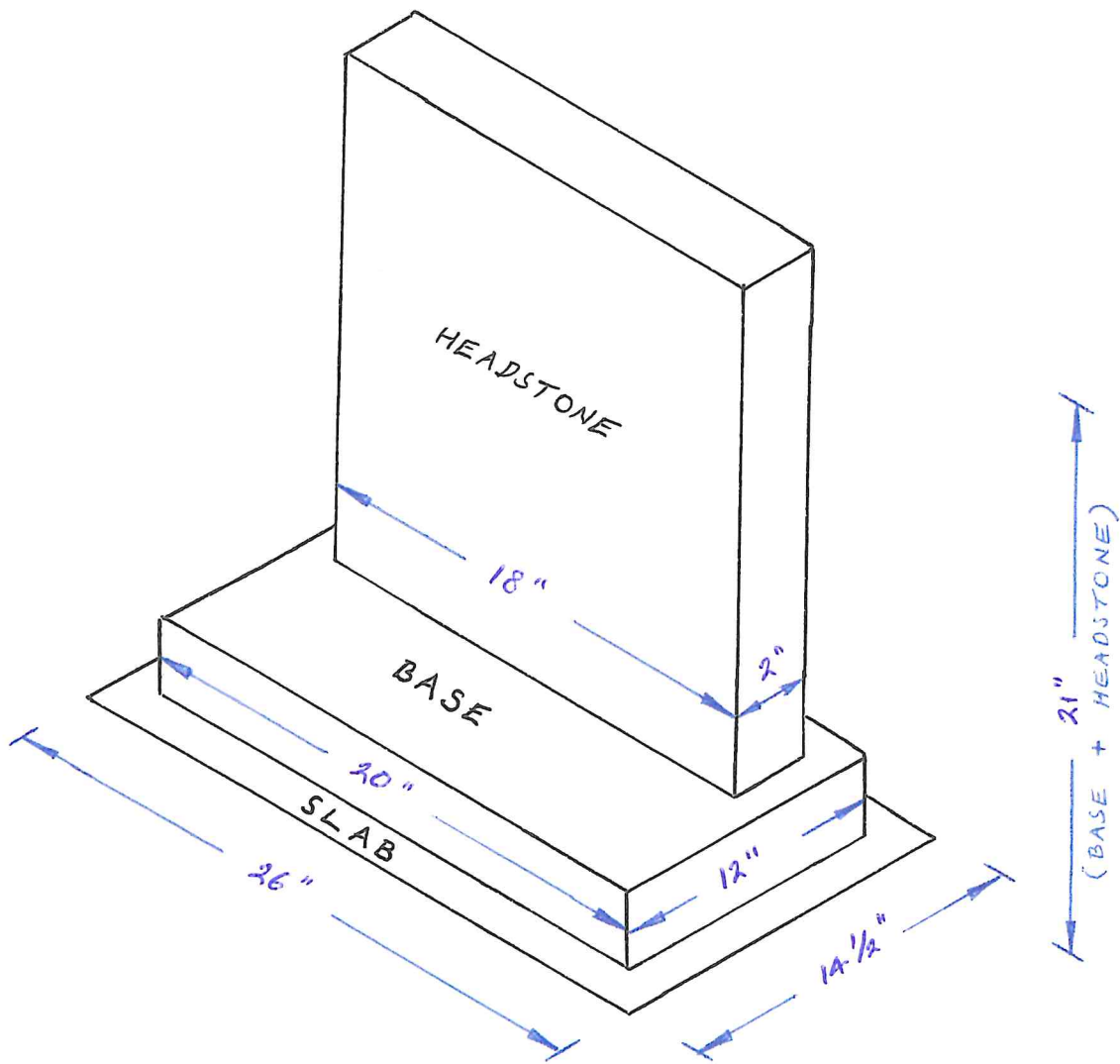

INSCRIBED VASE

C

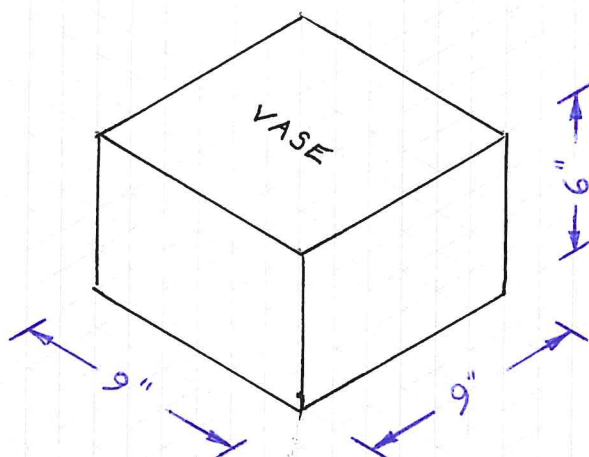

C

OLD GARDEN OF REST

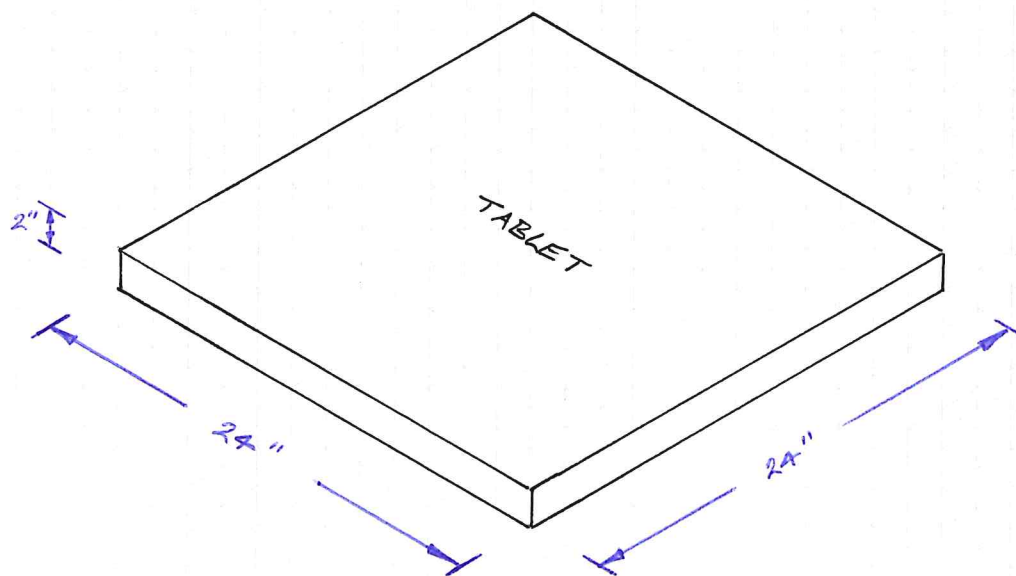
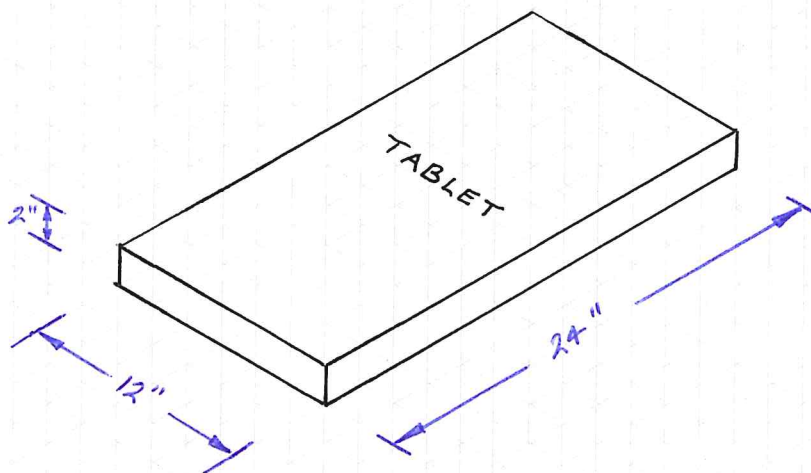

NEW GARDEN OF REST

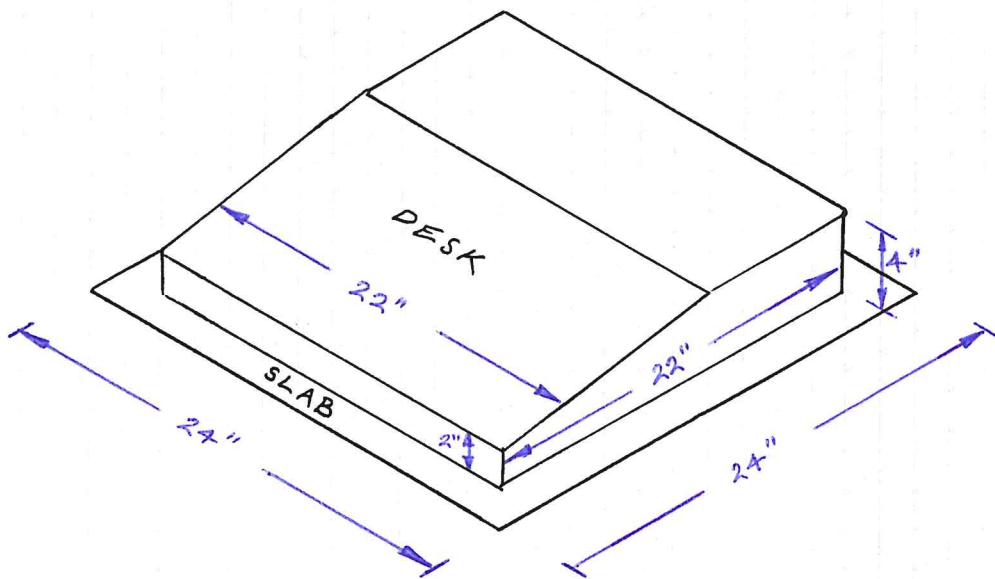
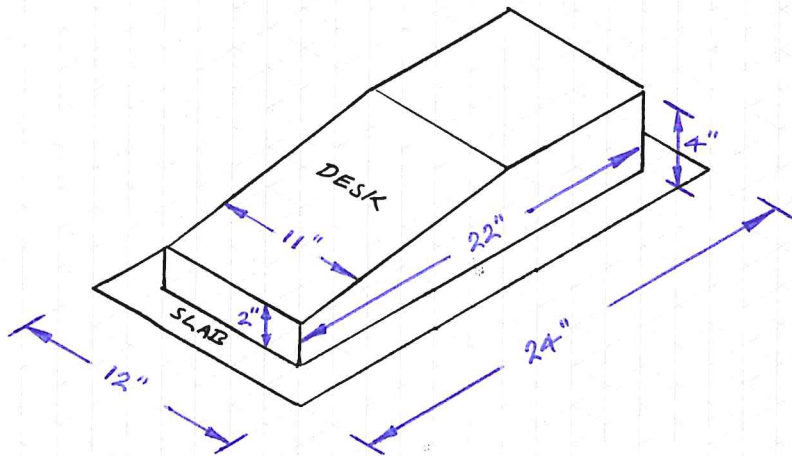



RINGWOOD TOWN COUNCIL

CEMETERY FEES 2022/23

These fees apply to applications received on or after 1st April 2022 and are payable on submission of application (save those reclaimable from the Children's Funeral Fund for England which will not be charged to the applicant).

Interment Fees	Parishioner	Non-Parishioner
Young child (under 7 years of age)*	£46	£184
Child (between 7 & 17 years of age)	£46	£184
Person aged 18 and over	£288	£1152
Burial of Ashes*	£144	£576
Scattering or Pouring of Ashes*	£62	£248

* Includes grave digging by Council staff

Purchase of Exclusive Rights of Burial in space for coffin burial for 30 years

Child's grave (under 12 years)	£206	£824
Earth grave age 12 and over	£463	£1852
Construction of Walled Grave or Vault (in Old Section only)	All costs to be borne by Applicant but no additional charge by Council	

Purchase of Exclusive Right of Burial of Ashes plot for 30 years

Single plot (with one plot number)	£129	£516
Double plot (with two consecutive plot numbers)	£257	£1028

Renewal of Grant of Exclusive Right of Burial for further 10 years

Plot of any kind ¹ - charge per plot	£31	£124
---	-----	------

Registration of Transfer of Exclusive Right of Burial

Voluntary assignments	£75	£75
Involuntary transfers (usually after death of last registered rights owner)	FREE	

Miscellaneous

Making a search of Cemetery or Memorial records	First 15 minutes free of charge, thereafter £41 per hour required
Faculty for Exhumation in Consecrated Ground	As charged by Diocese

¹ If application is made to renew a grant made (or previously renewed) for a total term of less than 30 years, it will be extended to the date on which it would have expired if originally granted for a term of 30 years, without fee.

C

APPLICATION FOR A MEMORIAL APPROVAL (PURCHASED GRAVES ONLY)

		Parishioner	Non-Parishioner
Headstone with base Book Memorial Lawn type headstone or other memorial Name plaque on grave	900 x 300 x 900mm 3' x 1' x 3'	Unconsecrated £144	£576
Headstone with base Book Memorial, Lawn type headstone or other memorial, Name Plaque on grave and Charge to meet faculty in Consecrated Ground where work is required to monuments payable with memorial fees		Consecrated £412	£1648
Vase with name inscribed		£67	£268
Each inscription after the first		£67	£268
Photo plaque on headstone		No charge	No charge
Flat stone (where no room on an existing memorial for added inscription)	12" x 18"	£82	£328

Memorials in New Garden of Rest for Purchased Cremation Plots

Each single plot has a plot number	22" x 11" x 4" <i>sloping to 2"</i> 550 x 275 x 101mm	£82	£328
Each double plot has two consecutive plot numbers CONCRETE SLAB UNDER ASHES TABLET 24" X 24" OR 24" X 12"	22" x 22" x 4" <i>sloping to 2"</i> 550 x 550 x 101mm	£165	£660

Memorials in Old Garden of Rest (note size differs)

Single plot size	Memorial size 24" x 12" x 2"	£82	£328
Double plot size	24" x 24" x 2"	£165	£660



RINGWOOD TOWN COUNCIL

C

CEMETERY FEES 2023/24

These fees apply to applications received on or after 1st April 2023 and are payable on submission of application (save those reclaimable from the Children's Funeral Fund for England which will not be charged to the applicant).

Interment Fees	Parishioner	Non-Parishioner
Young child (under 7 years of age)*	£50	£200
Child (between 7 & 17 years of age)	£50	£200
Person aged 18 and over	£300	£1,200
Burial of Ashes*	£150	£600
Scattering or Pouring of Ashes*	£75	£300

* Includes grave digging by Council staff

Purchase of Exclusive Rights of Burial in space for coffin burial for 30 years

Child's grave (under 12 years)	£300	£1,200
Earth grave age 12 and over	£600	£2,400
Construction of Walled Grave or Vault (in Old Section only)	All costs to be borne by Applicant but no additional charge by Council	

Purchase of Exclusive Right of Burial of Ashes plot for 30 years

Single plot (with one plot number)	£155	£620
Double plot (with two consecutive plot numbers)	£310	£1,240

Renewal of Grant of Exclusive Right of Burial for further 10 years

Plot of any kind ¹ - charge per plot	£45	£180
---	-----	------

Registration of Transfer of Exclusive Right of Burial

Voluntary assignments	£90	£360
Involuntary transfers (usually after death of last registered rights owner)	FREE	

Miscellaneous charges

Making a search of Cemetery or Memorial records	First 15 minutes free of charge, thereafter £45 per hour required	
Disinterment (any) Note: The applicant is responsible for applying for consent from the Ministry of Justice or faculty from the Diocese (as the case may be) and bearing all costs in connection with it	£75	£300

¹ If application is made to renew a grant made (or previously renewed) for a total term of less than 30 years, it will be extended to the date on which it would have expired if originally granted for a term of 30 years, without fee.

FEES FOR APPROVAL OF MEMORIALS (PURCHASED GRAVES ONLY)

Annex 4

C

	Parishioner	Non-Parishioner
Headstone with base Book Memorial Lawn type headstone or other memorial Name plaque on grave	Unconsecrated £90	 £360
Headstone with base Book Memorial, Lawn type headstone or other memorial, Name Plaque on grave (includes £35 charge to meet cost of faculty if Council is required to repair or remove the memorial)	Consecrated £125	 £395
Vase with name inscribed	£90	£360
Each inscription after the first	£45	£90
Photo plaque on headstone	No charge	No charge
Flat stone (where no room on an existing memorial for added inscription)	£90	£360

Memorials in either Garden of Rest for Purchased Cremation Plots

Each single plot has a plot number	£90	£360
Each double plot has two consecutive plot numbers	£180	£720

Current Projects Update

D

Note: Projects marked as "on hold awaiting officer availability" are reviewed fortnightly. Numbers (where given) indicate position in the queue for resumption.

No.	Name	Status	Recent developments	Description and notes	Lead Officer/Member	Financing
Full Council						
FC1	Long Lane Football Facilities Development	In progress (scheduled for completion in 2023)	The application for the PWLB loan is with DLUHC. The artificial turf pitch has been completed and handed over. A Pre-contract Services Agreement for the pavilion and other works has been entered into.	A joint venture with Ringwood Town Football Club and AFC Bournemouth Community Sports Trust to improve the football facilities for shared use by them and the community.	Town Clerk	The current expectation is that the Council's contribution to the project will, in effect, be limited to a modest loss of income from the site (but over a long term).
Planning Town & Environment Committee						
PTE1	Neighbourhood Plan	In progress	Pre-submission draft Plan approved by Full Council 25/01/2023. Regulation 14 public consultation in progress until 19/03/2023.	To prepare a Neighbourhood Plan for the civil parish of Ringwood but limited in scope to a few specified themes.	Deputy Clerk	Budget of £21,500 (£3,800 in 2021/22 budget, £3,000 in General Reserve and £14,700 to be funded by Locality grant)
PTE2	Human Sundial	Complete, with exception of interpretation board	Work to refurbish human sundial and install surrounding benches now complete. Repair of original time capsule cover stone has failed and will be removed for repair in March. Interpretation board with details of sundial, Jubilee Lamp etc. to be designed and costed.	Replacement of damaged sundial and surrounding paviers; installation of removable benches to protect it for the future - working with HCC (Principal Designer and Contractor)	Deputy Clerk	£5,295.15 spent from budget of £10,657 to be funded from CIL and contribution of £5,249.15 from Carnival
PTE3	Crow Stream Maintenance	Annual recurrent	Spraying of stream banks undertaken 21/04/2022, annual flail carried out in August and stream clearance carried out on 29th September.	Annual maintenance of Crow Ditch and Stream in order to keep it flowing and alleviate flooding	Deputy Clerk	£1,120 spent to be funded by transfer from earmarked reserve
PTE4	Climate Emergency	In progress	Funds used to support Greening Campaign, community litter-pick and Flood Action Plan leaflets.	Minor funding to support local initiatives.	Cllr Deboos	Budget of £1,000
PTE5	Bus Shelter Agreement	In progress	Response awaited from ClearChannel on the financial complications and on request for use of advertising space.	Request by ClearChannel in Nov. 2020 for RTC to licence the bus shelters in Meeting House Lane and the advertising on them. Completion dependent on clarification of financial issues (VAT treatment and non-domestic rates revaluation).	Town Clerk	No financial implications
PTE6	Shared Space Concept - Thriving Market Place	In progress	Meeting held with NFDC & HCC on 28/11/2022 to consider a draft concept plan. Both authorities will now discuss internally to consider scope and resources required, prior to carrying out community engagement. HCC will carry out some survey work in May to establish travel and parking patterns and count vehicles, pedestrians and cyclists.	Concept for town centre shared space identified through work on the Neighbourhood Plan.	Deputy Town Clerk	
Projects being delivered by others which are monitored by the Deputy Clerk and reported to this committee:						
	A31 widening scheme	Complete	Scheme complete and road re-opened on 19 November.	Widening of A31 westbound carriageway between Ringwood and Verwood off slip to improve traffic flow; associated town centre improvements utilising HE Designated Funds	Highways England (HE)	HE funded
	SWW Water Main Diversion (associated with A31 widening scheme)	Complete	Bickerley reinstatement works being monitored.	Diversion of water main that runs along the A31 westbound carriageway.	South West Water / Kier	HE funded
	Moortown drainage improvements	In progress		HCC considering a controlled opening of the system in Moortown Lane to alleviate highway flooding	Hampshire CC	Developers contributions
	Pedestrian crossing Castleman Way	On hold	Site does not meet HCC criteria for toucan crossing. Agreed to revisit following promotion of cycle path through Forest Gate Business Park.	Toucan crossing in Castleman Way to improve pedestrian and cycle route between town centre and Moortown	Hampshire CC	Developers contributions
	Crow Lane Footpath	In progress	Developers' contributions paid to HCC to implement. Additional funds required to progress and approved by NFDC Cabinet on 02/11/2022 - report indicates delivery in 2024/25.	New footpath to link Beaumont Park with Hightown Road, alongside west of Crow Lane	Hampshire CC	Developers contributions
	Surfacing of Castleman Trailway	Complete	Surfacing works completed early April 2022.	Dedication and surfacing of bridleway between old railway bridge eastwards to join existing surfacing	Hampshire CC	Developers contributions

	Railway Corner	In progress	Project supported by RTC.	Project to improve and promote historical significance of triangle of land at junction of Hightown Road and Castleman Way.	Ringwood Society	
Policy & Finance Committee						
PF5	Poulner Lakes Lease	On hold	Awaiting track maintenance solution - see Recreation Leisure & Open Spaces Committee item RLOS21.	Negotiating a lease from Ringwood & District Anglers' Association of the part of the site not owned by the Council	Town Clerk	Some provision for legal advice or assistance may be needed eventually.
PF8	Bickerley legal title	In progress (Commenced Dec 2020. Resolution expected in July 2023.)	The Council has resolved to maintain its objection to the application and this will now be considered by the Tribunal. For legal reasons, only basic information will appear here. Councillors can obtain further details from the Town Clerk if needed.	An application to remove land from the Council's title has been made	Town Clerk	Staff time plus cost of external legal support (one-off budget agreed so far by members)
PF10	Councillors' use of email	In progress (Commenced May 2022. Aiming to complete initial actions by end of July 2023.)	The Council's IT support provider has supplied further cost information and changes will be implemented following the election in May.	Researching options and costs for equipping councillors with official email accounts and devices to facilitate compliance with data protection laws.	Town Clerk	The research phase has not cost anything but staff time. Ongoing software licence fees and setup and support costs will fall on annual budgets. Whether the figures agreed for these for 2033-24 will only become clear in time.
Recreation, Leisure & Open Spaces Committee						
RLOS4	Grounds department sheds replacement	In progress (Commenced design work in April 2021. Aiming to establish planning prospects and likely cost by April 2023.)	Initial drawings prepared by Cllr Briers and showing the scale and overall design concept were considered and approved by Carvers Working Party when it met in May 2022. Pre-application planning advice has been received from NFDC and considered. Officers are in discussions with a planning consultant.	A feasibility study into replacing the grounds maintenance team's temporary, dispersed & sub-standard workshop, garaging and storage facilities. Combined with a possible new car park for use by hirers of and visitors to the club-house.	Town Clerk	Revised capital budget of £4,000 (originally £10,000 until virement to RLOS19)
RLOS5	Cemetery development	In progress (Commenced design work in April 2021. Aiming to establish planning prospects and likely cost by April 2023.)	CDS has produced a detailed design which was approved in principle at the committee meeting in September. Funding arrangements were agreed at the Policy & Finance Committee meeting on 21st September. Officers proceeding with contract procurement.	Planning best use of remaining space, columbarium, etc.	Town Clerk	Capital budget of £25,000 (carried into an earmarked reserve)
RLOS7	Bowling Club lease	In progress (Club renewed request for new lease in Jan 2022. Progress depends on negotiations.)	Renewal terms have been agreed in outline. A draft lease has been submitted to the Club's legal representative.	Request by Ringwood Bowling Club for existing lease to be renewed (current lease expires at the end of April 2023). The lease terms will also be reviewed for suitability to current and future needs.	Town Clerk	Staff time only (unless outside legal assistance is deemed necessary). The rental income will be reviewed as part of the renewal.
RLOS8	Ringwood Youth Club	In progress (aiming to complete by August 2023)	The meetings required to wind up the organisation have been arranged in February.	Winding up the redundant CIO to terminate filing requirements	Town Clerk	
RLOS10	Waste bin replacement programme	In progress (Commenced April 2020)	The first 17 bins have been installed. The next batch have been received and will be installed in the early months of 2023.	Three-year programme to replace worn-out litter and dog-waste bins	Grounds Manager	Budget of £2,000 a year.
RLOS12	Van replacement	Closed	This matter will be revived when the existing vehicle reaches its scheduled replacement date.	Replacing the grounds department diesel van with an electric vehicle	Grounds Manager	
RLOS14	Poulner Lakes waste licence	In progress	Surrender requirements are being researched.	Arranging to surrender our redundant waste licence to avoid annual renewal fees	Town Clerk	
RLOS17	New allotments site	In progress (Commenced March 2020, aiming to complete in or about April 2023)	Land transfer deed was sealed following the Council meeting on 25 January. Arrangements for site remediation and completion of the deed are being pursued.	The transfer to this Council (pursuant to a s.106 agreement) of a site for new allotments off Crow Arch Lane	Town Clerk	Staff time only
RLOS18	Cemetery map and registers digitisation	On hold.	All registers have been scanned. A digital map is now live. Costs estimate for completing data entry from registers requested but not received in time for inclusion in 2023-24 budget. Work will be resumed in Autumn 2023.	Digitisation of cemetery records to facilitate remote working, greater efficiency and, eventually, direct public access	Town Clerk	Revised capital budget of £5,467 (originally £5,000).
RLOS19	Carvers Strategic Development	In progress (Commenced Feb. 2021)	Landscape designer New Enclosure has been appointed and met with members. A topographic survey has been done. A meeting of the working party to consider the draft sketch of the 'masterplan' has been arranged for 3rd March.	Devising a strategic vision and plan for the future of Carvers Recreation Ground pulling together proposals for additional play equipment and other features	Carvers Manager	Revised budget of £6,000 (virement from RLOS4).

D

RLOS21	Poulner Lakes track maintenance	In progress (under discussion since Jan. 2021)	Costs estimates for re-surfacing schemes obtained from two suppliers. NFDC officers have been consulted about related mitigation schemes and possible support.	Devising a sustainable regime for maintaining the access tracks at Poulner Lakes to a more acceptable standard.	Town Clerk	Yet to be settled
RLOS22	Bickerley parking problem	In progress (under discussion since Jan. 2019)	"No Parking" signs have been installed. Replacement timber for "dragon's teeth" has been bought and is being installed progressively. A decorative sign reinforcing the message has also been installed. The cost of relocating the dragon's teeth to narrow the tracks is being investigated.	Unauthorised parking on the tracks crossing the Bickerley is causing damage and obstruction	Town Clerk	The Council is wholly responsible for the cost of whatever measures are taken including staff time. Six No Parking signs cost £156.72. The decorative sign cost £1,244.

D

Staffing Committee

None

Proposed/Emerging Projects Update

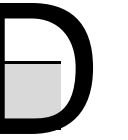

No.	Name	Description	Lead	Recent developments	Progress / Status Stage reached	Estimated cost	Funding sources
-----	------	-------------	------	---------------------	------------------------------------	----------------	-----------------

Full Council
None

Planning Town & Environment Committee

Roundabout under A31	Planting and other environmental enhancements			Area being used by National Highways for storage of materials during works to widen the A31.	Floated as possible future project		
Lynes Lane re-paving Rear of Southampton Road	Ringwood Society proposal Proposal by Ringwood Society to improve appearance from The Furlong Car Park and approaches				Floated as possible future project Floated as possible future project		
Dewey's Lane wall	Repair of historic wall			Re-build/repair options and costs are being investigated	Shelved as a TC project		
Signage Review	Review of signs requiring attention - e.g. Castleman Trailway, Pocket Park, Gateway Square	Cllr Day			Floated as possible future project		
Crow ditch	Investigate works required to improve capacity and flow of ditch alongside Crow Lane, between Hightown Road and Moortown Lane						Developers contributions

Policy & Finance Committee

Paperless office	Increasing efficiency of office space use	Cllr. Heron		Discussions with Town Clerk and Finance Manager			
------------------	---	-------------	--	---	--	--	--

Recreation, Leisure & Open Spaces Committee

None	(Current projects expected to absorb available resources for several years)						
------	---	--	--	--	--	--	--

Staffing Committee

None							
------	--	--	--	--	--	--	--

Closed Projects Report

No.	Name	Description	Outcome	Notes
Full Council				
FC2	Strategic Plan	Exploring ideas for medium term planning. Aim to have complete for start of budget-planning in Autumn 2022.	Completed in October 2022	
Planning, Town & Environment Committee				
	Pedestrian Crossings - Christchurch Road	Informal pedestrian crossings to the north and south of roundabout at junction of Christchurch Road with Wellworthy Way (Lidl)	Completed by HCC	
	Cycleway signage and improvements	New signage and minor improvements to cycleway between Forest Gate Business Park and Hightown Road	Completed by HCC	
	Carvers footpath/cycle-way improvement	Creation of shared use path across Carvers between Southampton Road and Mansfield Road	Completed by HCC	
	Replacement Tree - Market Place	New Field Maple tree to replace tree stump in Market Place.	Completed in January 2022 by HCC	
Policy & Finance Committee				
PF1	New Council website	Arranging a new website that is more responsive, directly editable by Council staff and compliant with accessibility regulations.	Completed	
PF2	Greenways planning permission	Consideration of applying to renew planning permission for bungalow in garden previously obtained	Decided not to renew	
PF3	Detached youth outreach work	To provide youth workers for trial of detached outreach work	Transferred to Recreation Leisure & Open Spaces Committee (see RLOS20)	
PF4	Review of governance documents	A major overhaul of standing orders, financial regulations, committee terms of reference, delegated powers, etc. Routine periodic reviews will follow completion of this work.	Completed in July 2022	All governance documents will now receive routine annual reviews.
PF6	Health & Safety Management Support Re-procurement	Re-procuring specialist advice and support for discharge of health and safety duties	Completed in February 2023	
PF7	Financial Procedures Manual	Preparation of a new manual for budget managers and other staff detailing financial roles, responsibilities and procedures	Completed in September 2022	Will be updated by Finance Manager as necessary
PF9	Greenways office leases	The tenant of the first floor suite gave notice and left. The building was re-let as a whole to the tenant of the ground floor suite.	Completed in November 2022	
Recreation, Leisure & Open Spaces Committee				
RLOS1	War Memorial Repair	Repair by conservation specialists with Listed Building Consent with a re-dedication ceremony after.	Completed in 2021-22	
RLOS2	Bickerley Tracks Repair	Enhanced repair of tracks to address erosion and potholes (resurfacing is ruled out by town green status) and measures to control parking.	Fresh gravel laid in 2021-22.	No structural change is feasible at present.
RLOS3	Public open spaces security	Review of public open spaces managed by the Council and implementation of measures to protect the highest priority sites from unauthorised encampments and incursions by vehicles	Completed in 2021-22	
RLOS6	Community Allotment	Special arrangement needed for community growing area at Southampton Road	Ongoing processes adapted	Agreed to adopt as informal joint venture with the tenants' association
RLOS9	Aerator Repair	Major overhaul to extend life of this much-used attachment	Completed in 2021-22	
RLOS11	Ash Grove fence repair	Replacing the worn-out fence around the play area	Completed in 2021-22	
RLOS13	Bickerley compensation claim	Statutory compensation claim for access and damage caused by drainage works	Completed March 2022	Settlement achieved with professional advice
RLOS15	Acorn bench at Friday's Cross	Arranging the re-painting of this bespoke art-work	Completed in 2021-22	Labour kindly supplied by Men's Shed
RLOS16	Town Safe	Possible re-paint of this important survival, part of a listed structure	Suspended indefinitely in September 2022	Complexity and cost judged disproportionate to benefit
RLOS20	Detached youth outreach work	Trialling the provision of detached outreach work by specialist youth workers.	Completed in May 2022	
Staffing Committee				
S1	HR support contract renewal	Renewal of contract for the supply to the Council of specialist human resources law and management support	Completed in 2021-22	
S2	Finance Staffing Review	Reassessing staffing requirements and capacity for finance functions and re-negotiating staff terms	Completed in 2021-22	