

Development of Open Humanoid Platform DARwIn-OP

Inyong Ha¹, Yusuke Tamura¹, and Hajime Asama¹

Jeakweon Han² and Dennis W Hong²

¹Department of Precision Engineering, The University of Tokyo, Tokyo, Japan

(Tel : +81-3-5841-6456; E-mail: hainyong@robot.t.u-tokyo.ac.jp)

²Department of Mechanical Engineering, Virginia Tech, Virginia, USA

(E-mail: jk4robot@vt.edu)

Abstract: This paper presents the design method for a humanoid which has a network based modular structure and a standard PC architecture. Based on the proposed method, we developed DARwIn-OP which meets the requirements for an open humanoid platform. DARwIn-OP has an expandable system structure, high performance, simple maintenance, familiar development environment, and affordable prices. All resources of DARwIn-OP including source codes, circuit diagrams, mechanical CAD files, and parts information will be opened to the public.

Keywords: Humanoid, DARwIn, Open Platform

1. INTRODUCTION

Recently, many kinds of humanoids have been developed such as ASIMO[1], HRP[2], LOLA[3], and HUBO[4]. Based on these humanoids, various challenging robotics researches on motion planning, walking, manipulating, communication, vision processing, and artificial intelligence have been carried out and remarkable results also have been shown. From the overall point of view, it is no exaggeration to say that a humanoid is the most adequate platform for robotics research.

Although marvelous humanoids already exist, many researchers are still making efforts and spending their time to build new platforms. Of course, for some researchers, it can be an essential work to build a robot in itself because their design scheme is one of the most important research areas. But, for the others, it can be a burden to make a new robot and furthermore it also can be a major disincentive for research. Nevertheless, researchers have no choice but to build an appropriate platform for their own research field.

To solve this iterative problem, a humanoid must be constructed considering expandable-modifiable system structure, high performance, simple maintenance, familiar development environment, and affordable prices. Therefore, in this paper, we suggest the design method for humanoid platform DARwIn-OP (Dynamic Anthropomorphic Robot with Intelligence - Open Platform) as shown in Fig. 1 which has a network based modular structure and a standard PC architecture to meet above requirements.

2. SYSTEM OVERVIEW

Fig. 2 shows a network based modular structure and a standard PC architecture of DARwIn-OP. All devices such as actuators, sensors, LEDs, buttons, and external I/Os are connected to the sub controller by a serial bus network which fully supports DYNAMIXEL[5] protocol. Each device has a memory mapped operation



Fig. 1. Open humanoid platform DARwIn-OP

structure with designated ID.

For the main controller, we adopted the Intel's ATOM Z530 CPU which is normally used for netbooks. The main controller communicates with the sub controller by USB. The sub controller works as a gateway to access devices. Therefore, all devices are encapsulated as an USB device, which means that the development environment is just like a standard PC.

3. HARDWARE STRUCTURE

3.1 Mechanics

Fig. 3 illustrates overall mechanical design scheme of DARwIn-OP. The basic configuration of DARwIn-OP

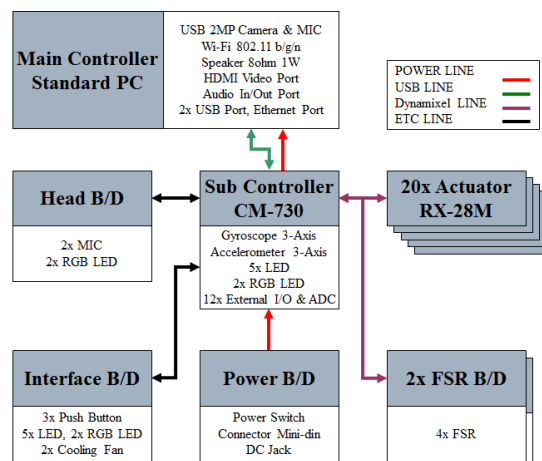

Fig. 2. System block diagram

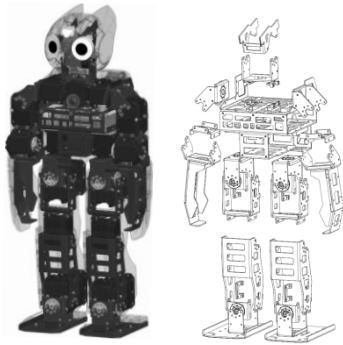

Fig. 4. Mechanical design of DARwIn-OP

has 20 degrees of freedom (DOF). The center of mass is located in the center of its pelvis. The location is optimal for proper balancing and proper distribution of inertia during gait, especially at the extremities. The kinematic information of DARwIn-OP is shown in Fig. 4.

The modular network-based nature of the robot can help the researcher modify any extremities by isolating the desired limb from the rest of the body with virtually no overall performance compromise of DARwIn-OP.

The frames for DARwIn-OP were designed for robot sturdiness and durability. The hollowness of the frames allows the robot to maintain a fairly low overall weight. The hollow frames were also designed with the assumption that the user will include additional sensors to the robot. The frames were designed to accommodate such additional sensors and their respective wiring. The hollow design maintains the scope of a network-based modular structure and facilitates periodic robot maintenance.

Various optional frames for connecting actuators and other devices were also designed. Such frames are for optional gripper-types for DARwIn-OP as in Fig. 5.

3.2 Actuators

We designed the new improved MX-28 actuator for DARwIn-OP shown in Fig. 6 which has a higher resolution, faster communication speed, and more powerful controller compared to the previous RX-28[6].

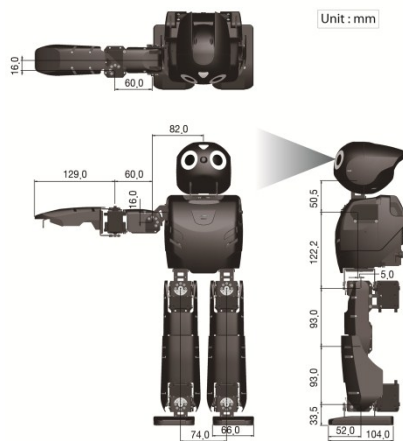

Fig. 3. Kinematics information of DARwIn-OP



Fig. 5. Different types of grippers for DARwIn-OP

The previous RX-28 featured a conventional potentiometer for position control. Over time the contact required to give proper position measurement eventually wears the potentiometer out. The MX-28 implements an absolute contactless magnetic potentiometer; its contactless aspect of the encoder virtually eliminates any limited operation angle of the actuator. Another feature of the MX-28, not featured on the previous RX-28, is the increased 12-bit resolution for more precise position control all over 360 degrees without any gaps or stops.

The MX-28 supports PID controller for position and speed control. The user can adjust not only position and speed profile but as well as PID gain parameter in real-time. One of the purposes of the accessibility of PID controls of the MX-28 is to minimize or control actuator harmonic resonance-related aspects. As a result, from a holistic standpoint, PID controls provide DARwIn-OP with the highest performance for a humanoid of its type.

3.3 Sensors

DARwIn-OP has pluralities of sensors as illustrated in Fig. 7 which maintains the scope of a network-based modular structure. Basic sensors are a 3-axis gyroscope and a 3-axis accelerometer for posture estimation and balancing are mounted in the upper body. A USB-based camera and a total of three microphones are located in the head. Optional sensors are force sensing registers (FSR) modules, in which four FSR's are placed in each foot, for ground reaction force measurements. Additional sensors also can be attached via external I/O at the user's discretion.

DARwIn-OP makes full use of the provided 3-axis accelerometer and gyroscope for balancing and posture estimation without compromising walking performance. In conjunction of proper implementation of closed-loop feedback control based on "immediate performance history" DARwIn-OP may be able to increase performance, such as faster walking or quicker recovery time after falling.

There is an USB-based camera for image processing



Fig. 6. MX-28 Actuator for DARwIn-OP

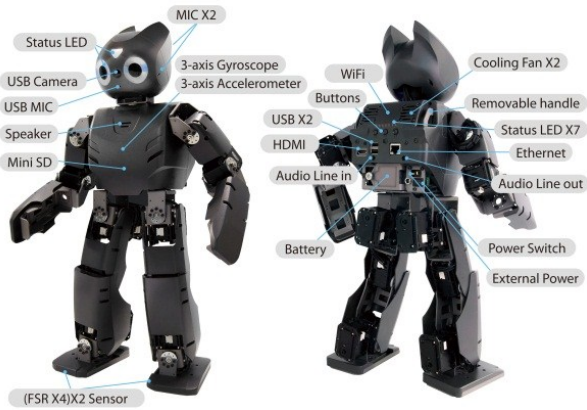

Fig. 7. Device Information

placed inside the head. Unlike many other humanoids the basic configuration of DARwIn-OP only requires a single camera. The camera is a high-definition camera that interfaces with the robot via the USB standard. The high-definition aspect of the camera provides much detailed information. Another result of implementing a high-definition camera is that a single camera device can help maintain a fairly robot simple configuration; therefore eliminating the need for a dedicated camera actuator. The flexibility of the USB standard allows implementation of any desired type of camera or multiple cameras for "stereo" vision. Last but not the least the USB-based camera eliminates the need of a dedicated camera power source therefore keeping the scope of the architecture simple.

The microphone allows DARwIn-OP to receive voice commands. A simple API can be installed in DARwIn-OP for voice recognition followed by any programmed sequential behavior from the voice command. Two additional microphones are also placed inside the head as well for the purposes of sound localization. Audio signals given by each microphone may be differentiated from each other by simple differential margin; where the robot can accurately localize the sound source by said differential margin. The additional microphones, in conjunction with the voice recognition microphone, can also be tools for improve sound localization for a more accurate source detection.

Additional force sensing registers are implemented on each foot (four sensors per foot) for more accurate ground reaction force. These sensors interface with DARwIn-OP with the same communications and power line shared by the actuators, while maintaining the daisy chain configuration. This common line eliminates the need to add a dedicated line for the FSR's helping keep architecture simple. Placing four sensors per foot allows for more precise information the specific amount of force in a specific area of the foot at a specific pose of DARwIn-OP during its walk. A closed-loop feedback control augmented with data from the FSR's can allow the researcher to refine DARwIn-OP's gait. Such data can also be implemented to improve gait during unexpected changes on walking surface.

3.4 Display and Interfaces

DARwIn-OP comes equipped with full-color range RGB LED's in the eyes and forehead. The researcher can program specific colors of each LED. The colors can help or alert the researcher visually in real-time with the status of DARwIn-OP. There are also status LEDs and buttons in the back panel. For purposes of direct development environment, DARwIn-OP is also equipped with external ports such as HDMI, USB, flash memory port, and Ethernet port. These external ports facilitate interfacing, communications, data storage, and software implementation with the robot due to the standardized nature of said external ports in their PC implementation. The external ports from the standard PC also maintain scope of the open architecture nature of DARwIn-OP.

4. SOFTWARE STRUCTURE

The software aspect of DARwIn-OP has been built with a hierarchical framework considering modularity and independency. The framework consists of device communication module, motion module, walking module, sensing module, behavior module, vision module, and diagnostics module. The framework has been developed with C++ programming language where the code is operating system-independent. The operating system-independent aspect of the framework is essential so that the code can be ported to any existing or future computer operating system, including the newly-developed Robot Operating System (ROS).

The user may simply write a behavioral code for DARwIn-OP without the need to develop a separate framework set. In such case software simulator is the most practical method of writing the program and testing said program for DARwIn-OP, given that such simulator makes use of the provided framework. Due to the open-source nature of DARwIn-OP the user is encouraged to share the developed program with other users. However, users may not be limited to open-DARwIn-SDK. There is currently other independently-developed software that does not

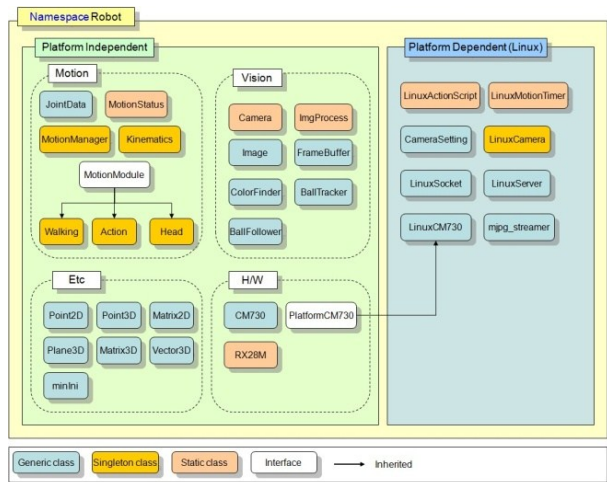

Fig. 8. Software framework for DARwIn-OP

implement open-DARwIn-SDK. There are some examples where software has been developed at “levels.” For instance low-level programming takes care of the robot’s sub-routines, such as camera refresh times or read the actuator’s position. The high-level programming can take care of the more abstract aspects of the robots. The different levels are practical so that recompiling of the entire code is unnecessary on simple changes in subroutine behaviors or parameters.

Table I. Overall specifications

Category	Description	Data
Dimension	Height	0.455m
	Weight	2.8Kg
DOF	Head	2 DOF
	Arm	2 x 3 DOF
	Leg	2 x 6 DOF
Main Controller	CPU	Intel Atom Z530 @1.6GHz
	RAM	1GB DDR2
	Disk	4GB Flash Disk
	Network	Ethernet/WiFi
Sub Controller	USB Port	2 x USB2.0
	CPU	ARM 32-bit Cortex-M3
	Frequency	72MHz
Actuator MX-28	Flash Memory	512KB
	SRAM	64KB
Sensor	Holding Torque	24kgf·cm @ 12V
	Speed	45RPM @ No Load
	Position Sensor	Magnetic Potentiometer
	Resolution	0.072°
Software	Command Interface	Serial 3MBPS
	Gyroscope	3-Axis
	Accelerometer	3-Axis
	Pressure-meter	2 x 4 FSR in Foot
Actuator MX-28	Camera	2MP HD USB
	O/S	Linux Ubuntu
	Framework	open-DARwIn SDK
	Language	C++ / Java
Actuator MX-28	Compiler	GCC

5. EXPERIMENT

We built demonstration program with framework open-DARwIn-SDK for evaluating the performance of

DARwIn-OP. Simple vision processing algorithm based on color tracking, gait pattern generator, and walk stabilizer are implemented on the robot. The control period is 8ms for the motion, and 30ms for the vision.

We can verify that DARwIn-OP can follow the ball with stable walking as shown in Fig. 9.

6. RESULT AND CONCLUSION

In this paper, we suggest the design method for humanoid which has a network-based modular structure and a standard PC architecture to meet the requirements for an open humanoid platform. Also, based on this method, we developed DARwIn-OP which has an expandable system structure, high performance, simple maintenance, familiar development environment, and affordable prices. DARwIn-OP’s key features are illustrated in Table I.

All resources of DARwIn-OP including source codes, circuit diagrams, mechanical CAD files, and parts information will be opened to the public. We hope that DARwIn-OP will contribute to promote robotics research.

REFERENCES

- [1] K. Hirai, M. Hirose, Y. Haikawa, and T. Takenaka, “The Development of Honda Humanoid Robot”, *International Conference on Robotics and Automation*, pp. 1321-1326, 1998.
- [2] K. Kaneko, K. Harada, F. Kanehiro, G. Miyamori, and K. Akachi, “Humanoid robot HRP-3”, *International Conference on Intelligent Robots and Systems*, pp. 2471-78, 2008.
- [3] S. Lohmeier, T. Buschmann, and H. Ulbrich, “Humanoid Robot LOLA”, *International Conference on Robotics and Automation*, pp. 775-780, 2009.
- [4] I.W. Park, J. Y. Kim, J. Lee, and J. H. Oh, “Mechanical Design of Humanoid Robot Platform KHR-3 (KAIST Humanoid Robot – 3:HUBO)”, *International Conference on Humanoid Robots*, pp. 321-326, 2005.
- [5] ROBOTIS Co, Ltd. Web Site, “http://support.robotis.com/en/product/dynamixel/dxl_communication.htm”
- [6] ROBOTIS Co, Ltd. Web Site, “http://support.robotis.com/en/product/dynamixel/rx_series/rx-28.htm”

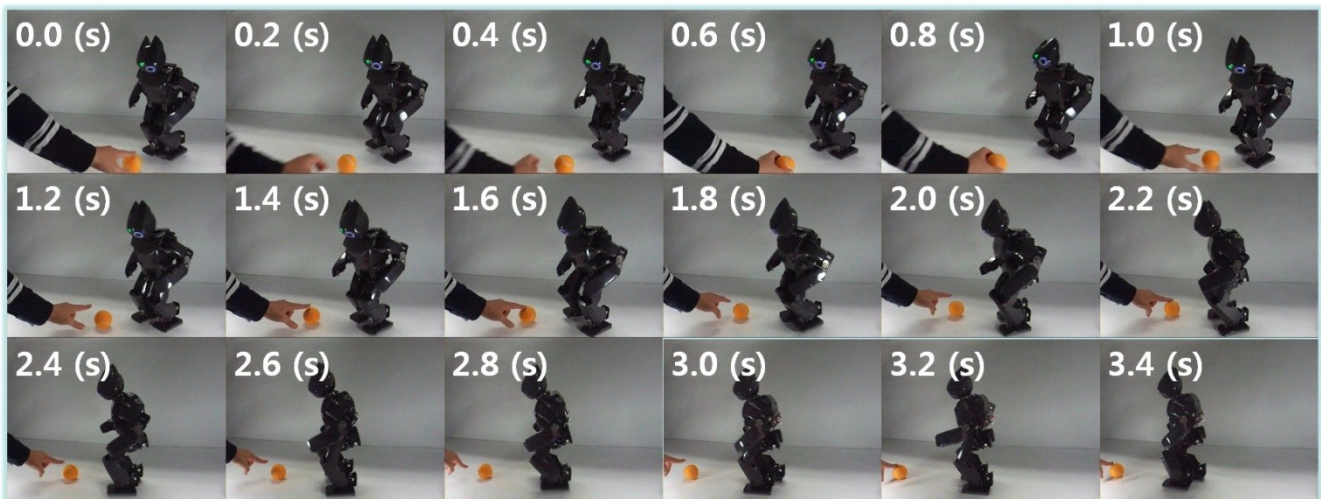

Fig. 9. Ball recognition and tracking demonstration of DARwIn-OP