



Railway Track and Signalling

**Aurizon Bulk SA&NT (and others)
SA Regional Network**

Section: SA & NT

Go to page 2 for index

G F Vincent 2012

Last Revised
29 October 2024
Diagram 929

REGIONAL SA & NT TRACK & SIGNAL INDEX

Page	Drawing	Section	Page	Drawing	Section
1	Cover	<i>Regional SA</i>			<i>Darwin Line SA>NT</i>
2		Index			
3	Sect. S	<i>Eyre Peninsula Line -- ng</i>	25	Sect. P	<i>Darwin Line</i>
4	S928	Thevenard	26	S1811	Northgate - Wirrida
5	S929	Penong Junction - Kevin	27	S1812	Rankin Dam - Manguri
6	Sect. E2	<i>Eyre Peninsula Line -- sg</i>	28	S1813	Cadney Park - Marryat
7	S1801	Spencer Junction-Whyalla YL	29	T1815	Kulgera -Alice Springs
8	Sect. E2a	<i>Whyalla Precinct -- sg</i>	30	T1817	Alice Springs
9	S1805	Whyalla AbSA Provisioning	31	T1819	Illoquara - Muckaty
10	S1806	Whyalla	32	T1821	Newcastle Waters - Katherine
11	S1807	Whyalla Unloader Loop	33	T1823	Edith River - Union Reef
12	S1808	Liberty Onsteel Casting Works	34	T1824	Adelaide River - (Durak)
13	S1809	Liberty Onsteel BOS	35	T1825	Brimmah - East Arm Wharf
14	Sect. S2a	<i>Whyalla Precinct -- ng</i>			<i>Heritage SA</i>
15	S941	Port of Whyalla	36	Sect. S3	<i>Pichi Richi Railway Preservation Society -- ng</i>
16	S942	Whyalla ng Terminal	37	S084	Port Augusta
17	Sect. S2	<i>Arrium Ore Line - ng</i>	38	S083	Stirling North
18	S943	Whyalla West	39	S951	Stirling North (ng) - Summit
19	S944	Middleback	40	S952	Quorn Loco - Quorn
20	S945	Iron Baron - Iron Duke	41	Sect. S4	<i>Steamranger Heritage Railway -- bg</i>
21	Sect. S6	<i>Northern PS Branch & Leigh Creek Line -- sg</i>	42	S953	Mount Barker Junction - Mount Barker
22	S083	Stirling North	43	S954	Strathalbyn - Gilberts
23	S932	Stirling North Yard	44	S955	Currency Creek - Goolwa
24			45	S956	Middleton - Victor Harbor

South Australia

LINE	Eyre Peninsula West
SECTION	Kevin Line
PAGES	928-929



▲ Home



■ Another Line

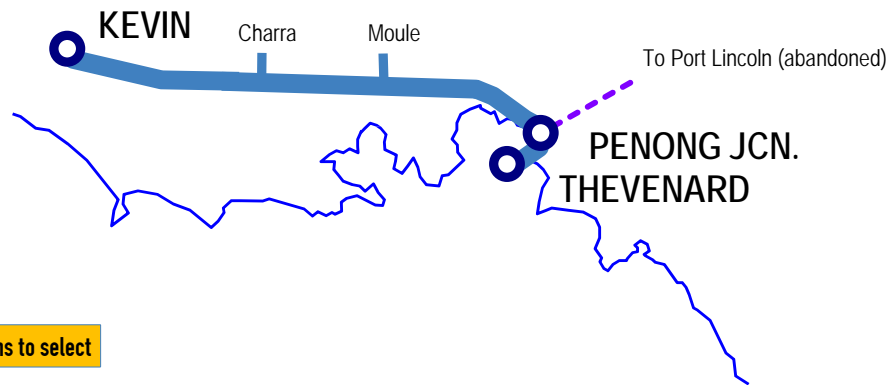

Click stations to select

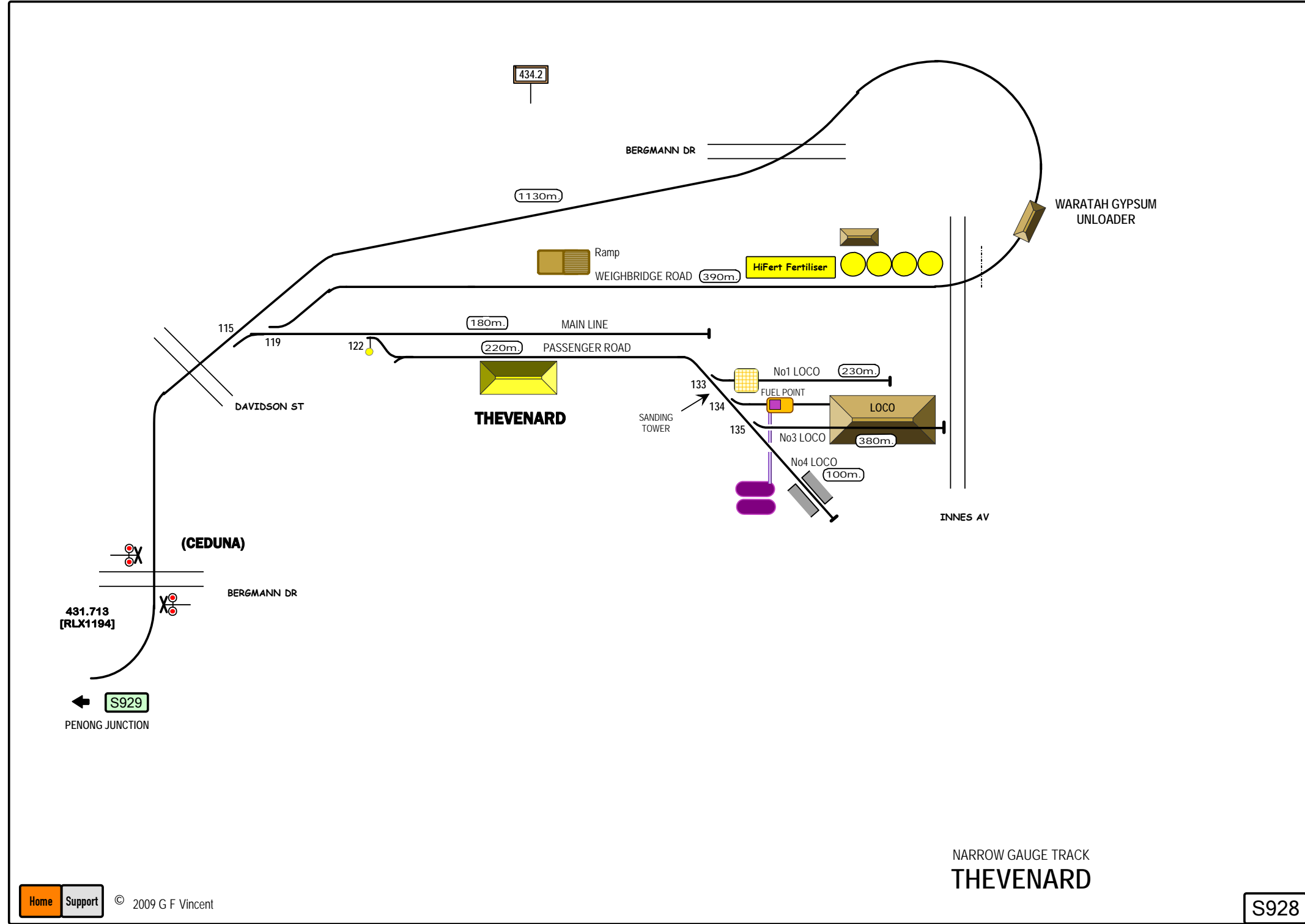

434.2

BERGMANN DR

1130m

WARATAH GYPSUM UNLOADER

Ramp
WEIGHBRIDGE ROAD

390m

HiFert Fertiliser

180m

MAIN LINE

220m

PASSENGER ROAD

THEVENARD

SANDING TOWER

133

No1 LOCO

230m

FUEL POINT

LOCO

134

380m

135

No3 LOCO

100m

No4 LOCO

INNES AV

(CEDUNA)

BERGMANN DR

431.713
[RLX1194]

S929

PENONG JUNCTION

NARROW GAUGE TRACK
THEVENARD

429.792
[RLX1189]

COLLINS ST
430.401
KLODEN ST -
PARK TCE X/OVER
430.766

→ S928
THEVENARD

EYRE HWY

(CEDUNA)

PENONG JUNCTION

429.7

114

432.473
GOODE RD

434.497
[RLX1195]

441.175

443.131

444.803

445.6

448.689

455.337

460.222

460.370

465.068

Line to WUDINNA
closed

PTS

EYRE HWY

CARPENTER
CORNER RD

QUARRY RD

MOULE

HOFFRITCHERS RD

ATHERMAN RD

DENIAL BAY RD

WIRE GATE
TANK RD

TROWBRIDGE RD

466.856

470.098

470.102

475.597

477.814

485.753

POINT BELL RD

CHARRA

MEWETT RD

DENTON RD

CHAROBAN RD

EAST APEX

659m

Gypsum loading

SOUTH APEX

144

490m

145

490.1

KEVIN

145

146

147

306m

380m

148

eol 494.74

PENONG line
(closed)

NARROW GAUGE TRACK

PENONG JUNCTION - MOULE

Home Support

© 2009 G F Vincent

S929

LINE	Whyalla Branch
SECTION	Spencer Junction - Whyalla
PAGES	1801, 1085 - 1089

South Australia



▲ Home



■ Another Line

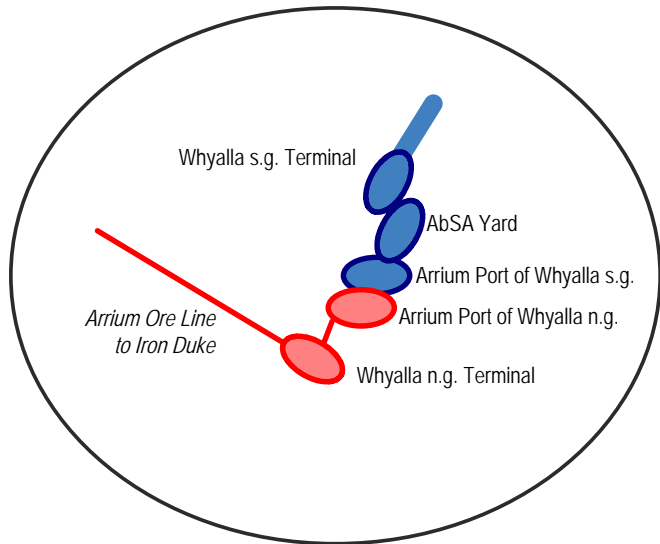
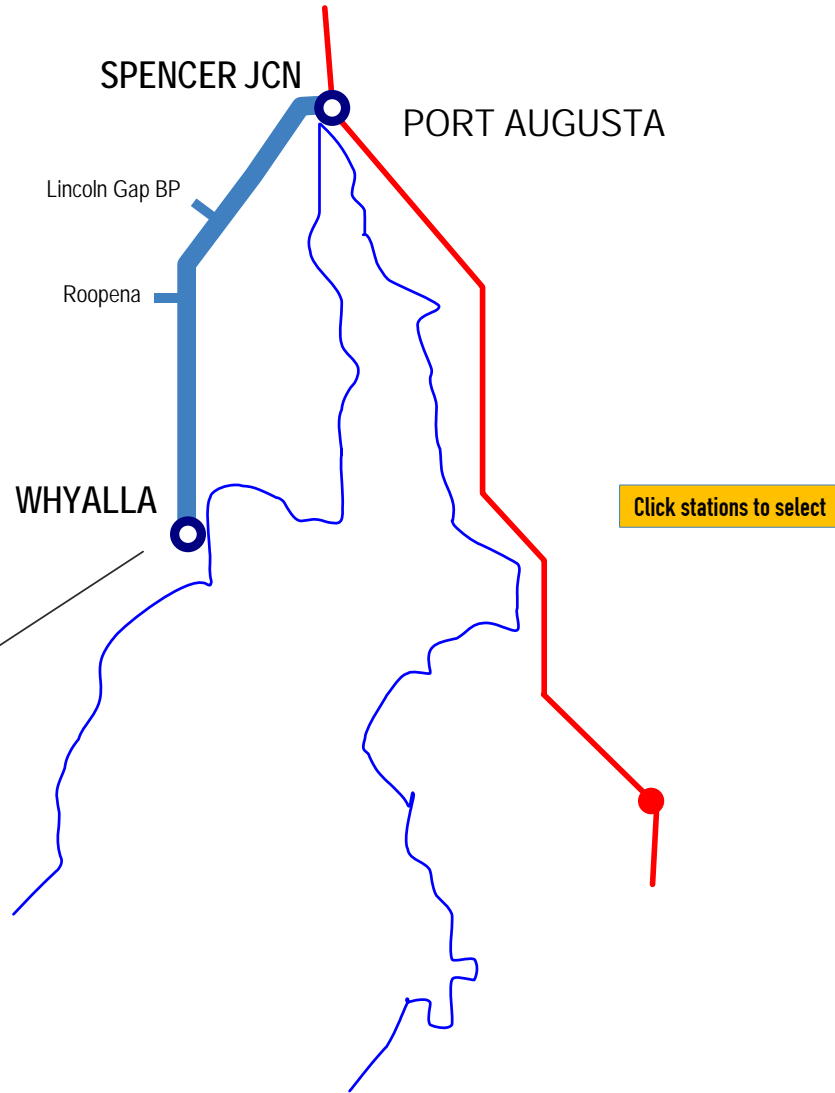

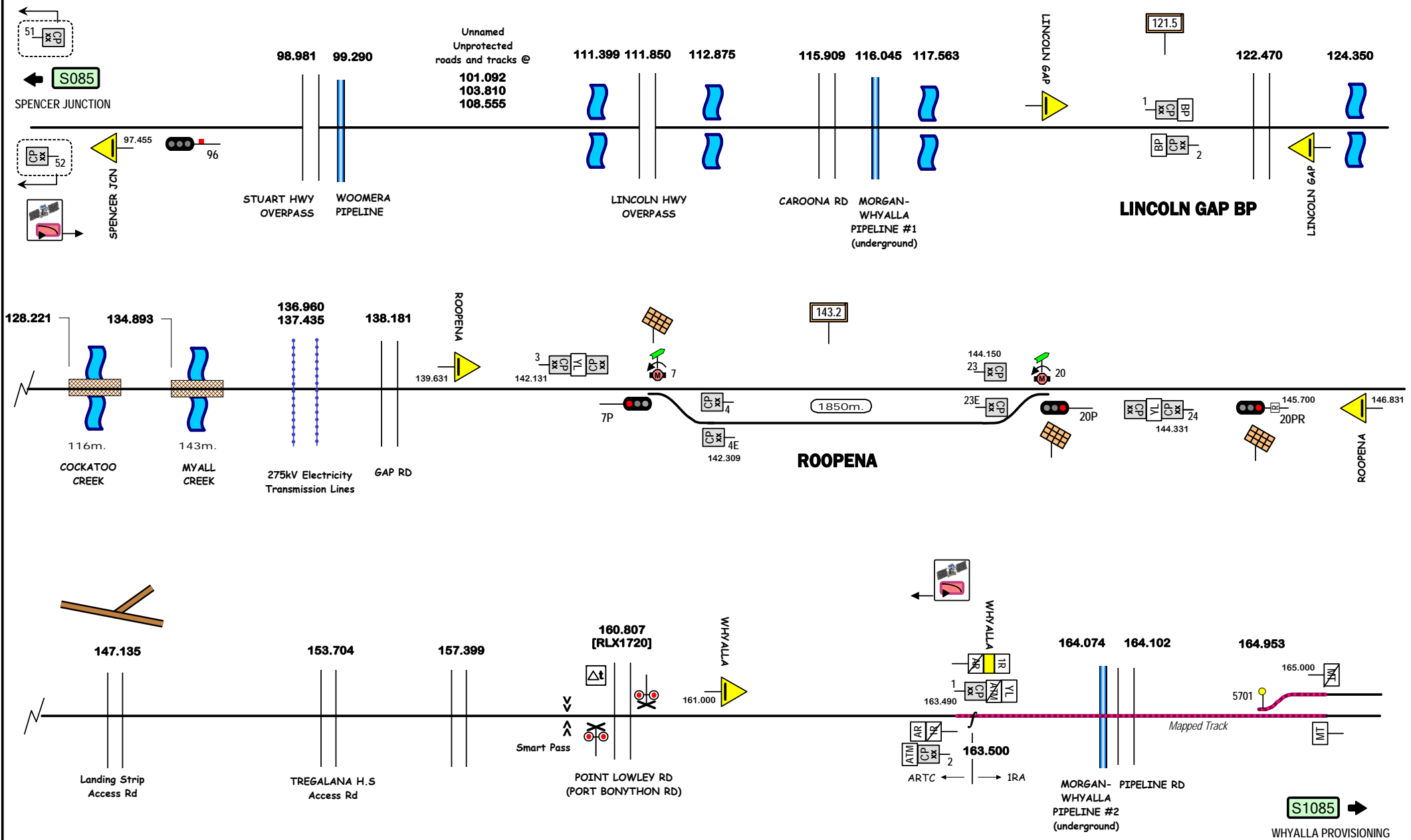

© 2020 G F Vincent

Signal Locations

Home Support

← ATMS on this section

3 Control Point (ATMS) (number)

Points under ATMS control

STANDARD GAUGE TRACK
**SPENCER JCN (YL) -
 AURIZON BULK SA (WHYALLA) INTERFACE**

S1801

LINES	Spencer Junction > Whyalla > Iron Duke
SECTION	Whyalla Environs
PAGES	941 - 943 & 1085 - 1089

South Australia

 Home

 Another SG Line

 Another NG Line

Click lines or yards to select

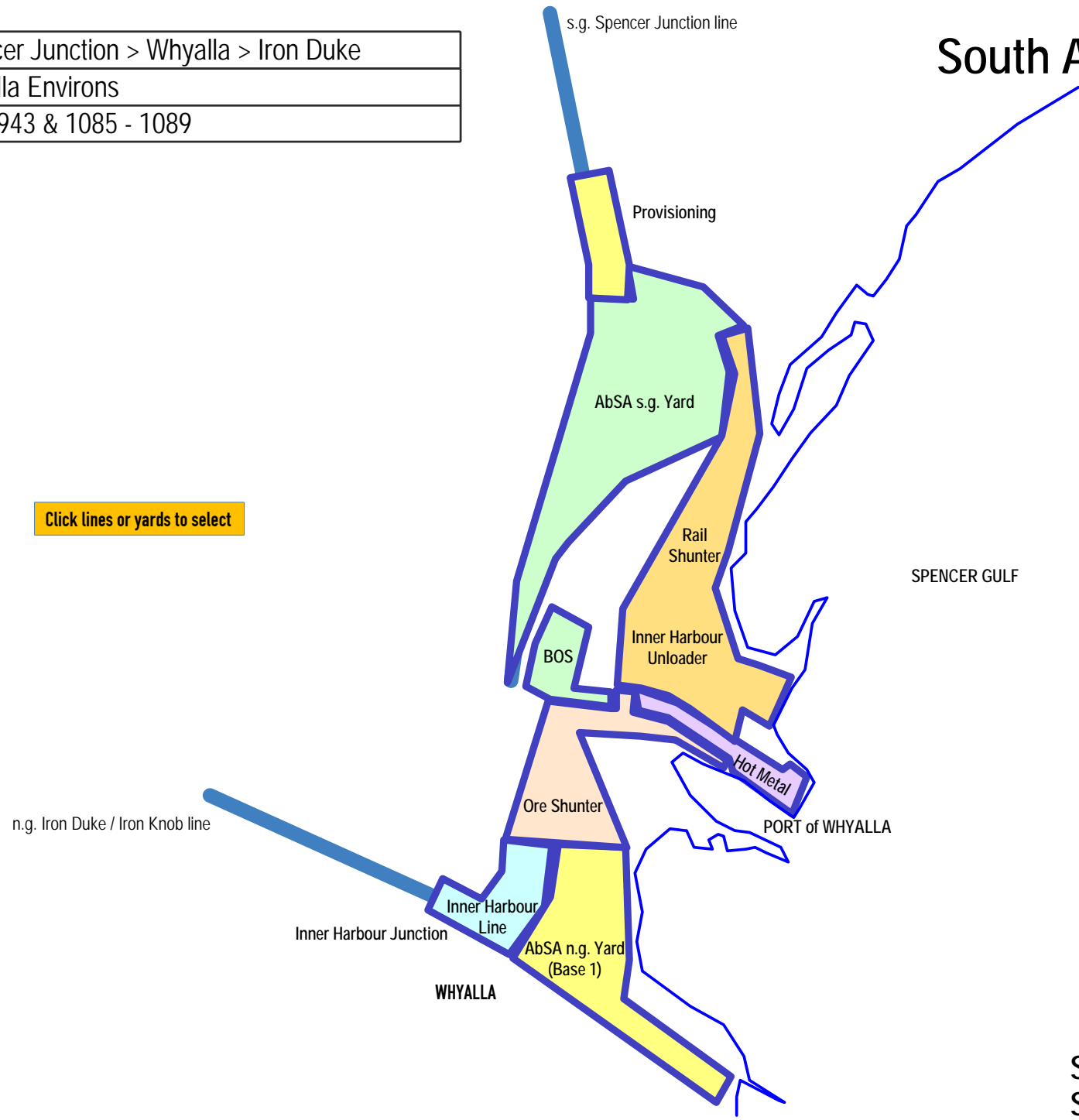

Section E2a
Section S2a

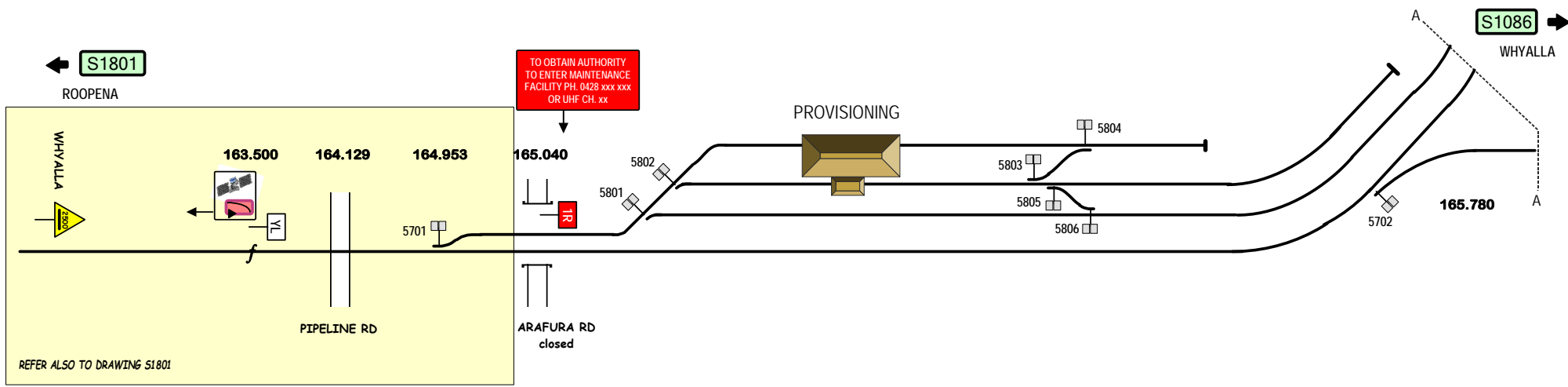

REFER ALSO TO DRAWING S1801

STANDARD GAUGE TRACK

AURIZON BULK SA -- WHYALLA PROVISIONING

 The green/yellow point position indicators in this yard provide the indication in both directions

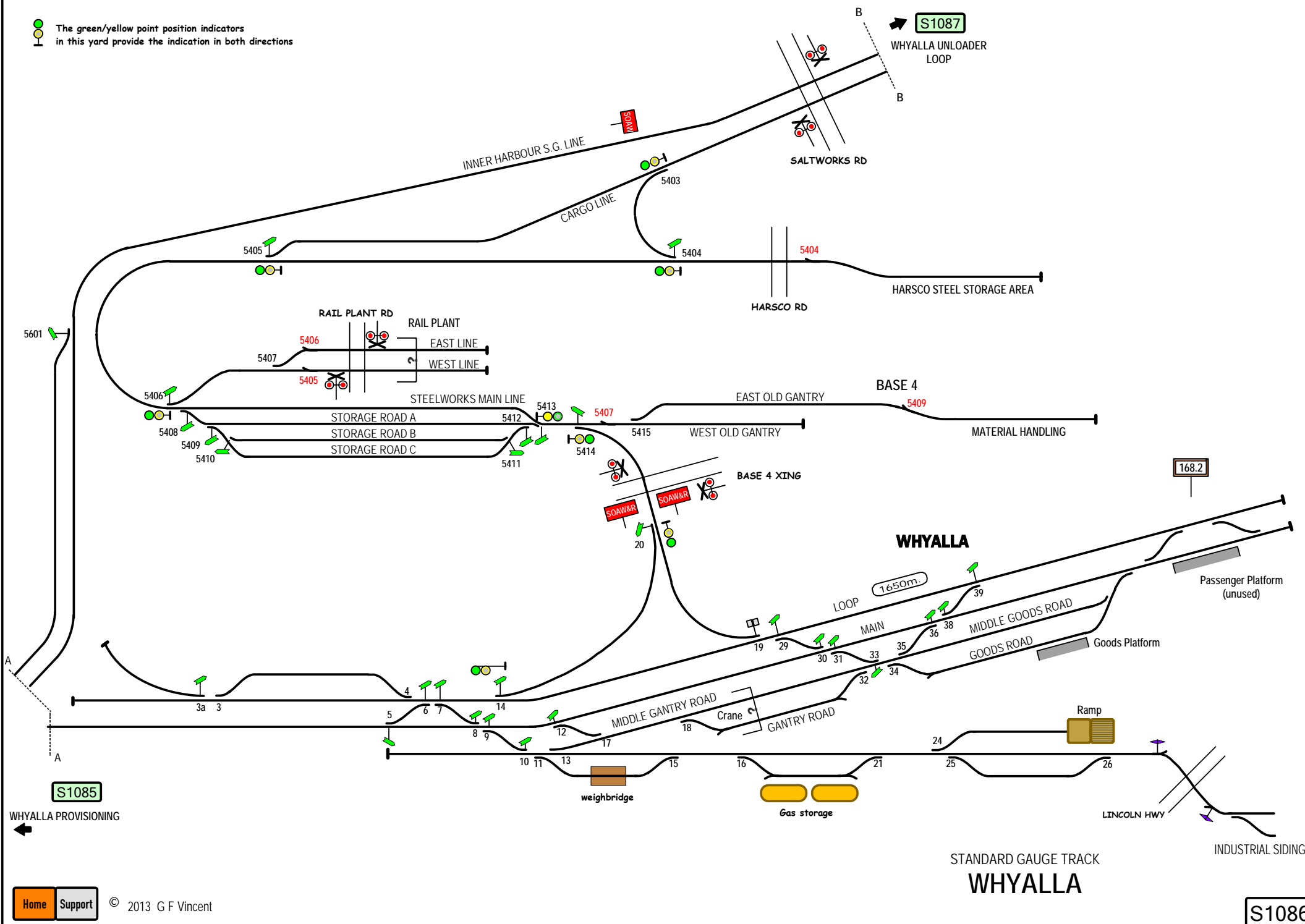

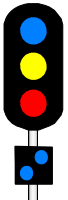

- BLUE: SG set for CARGO Line.
- YELLOW: NG >>5503 displaying YELLOW, or SG set to CRUSHER Line.
- YELLOW FLASHING: NG >>5503 displaying RED
- BLUE Subsidiary: NG Low Speed > 5503 Track may be occupied

SPECIAL CONFIGURATION
5505

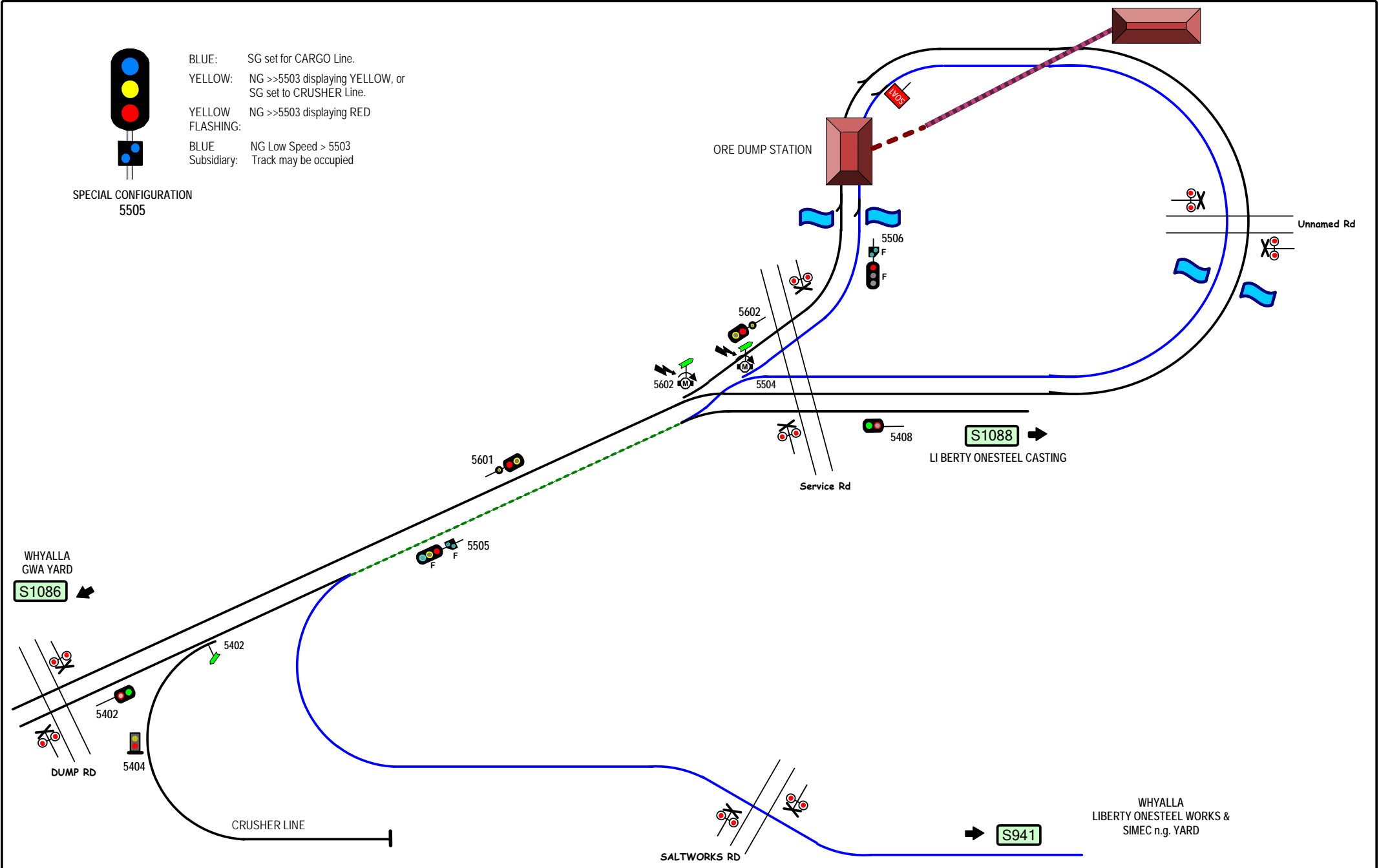

WHYALLA
GWA YARD
S1086

S1088 →
LIBERTY ONESTEEL CASTING

WHYALLA
LIBERTY ONESTEEL WORKS &
SIMEC n.g. YARD

→ S941

- STANDARD GAUGE TRACK
- MIXED (sg+ng) GAUGE TRACK
- NARROW GAUGE TRACK

WHYALLA UNLOADER LOOP

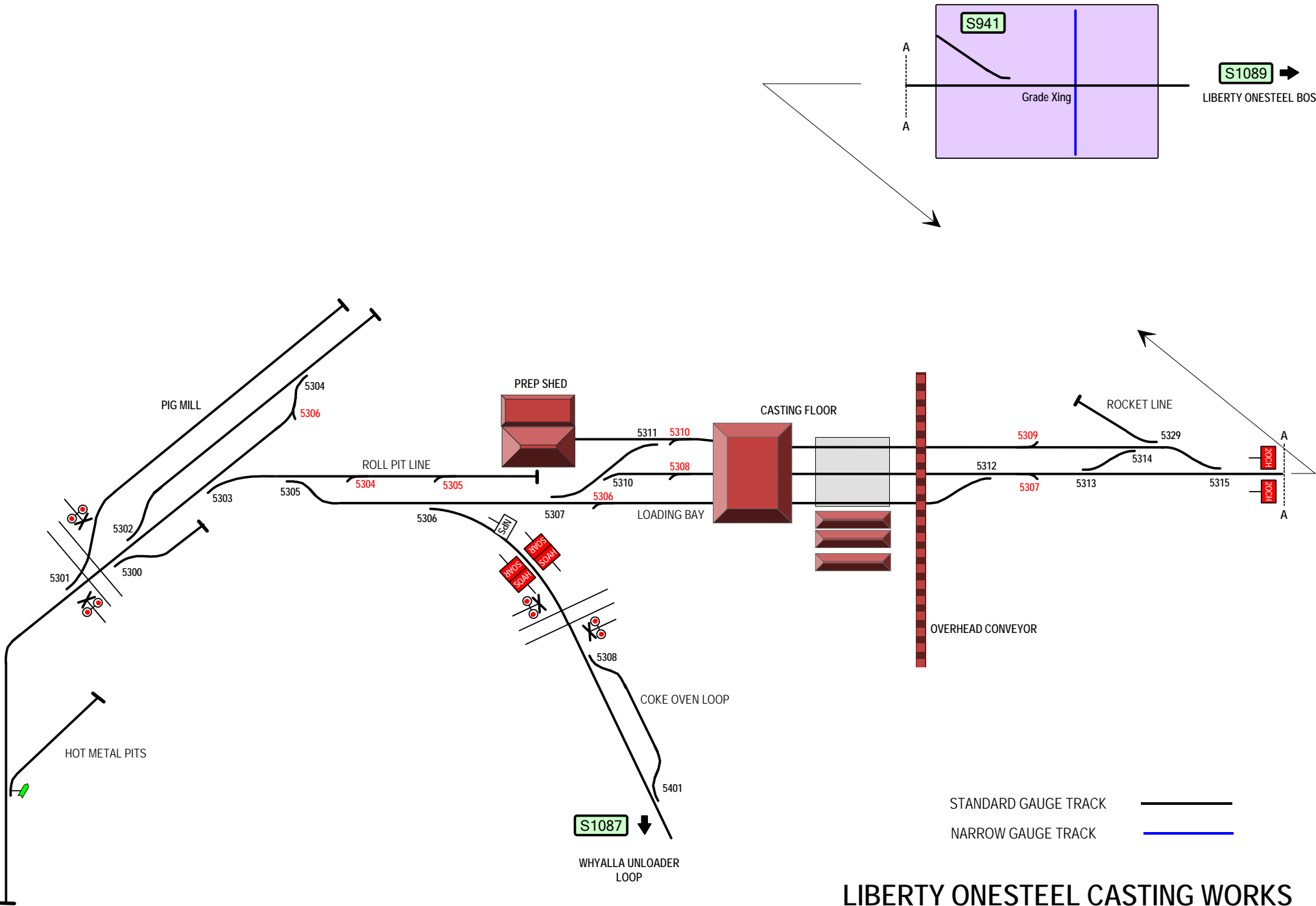

LIBERTY ONESTEEL CASTING WORKS

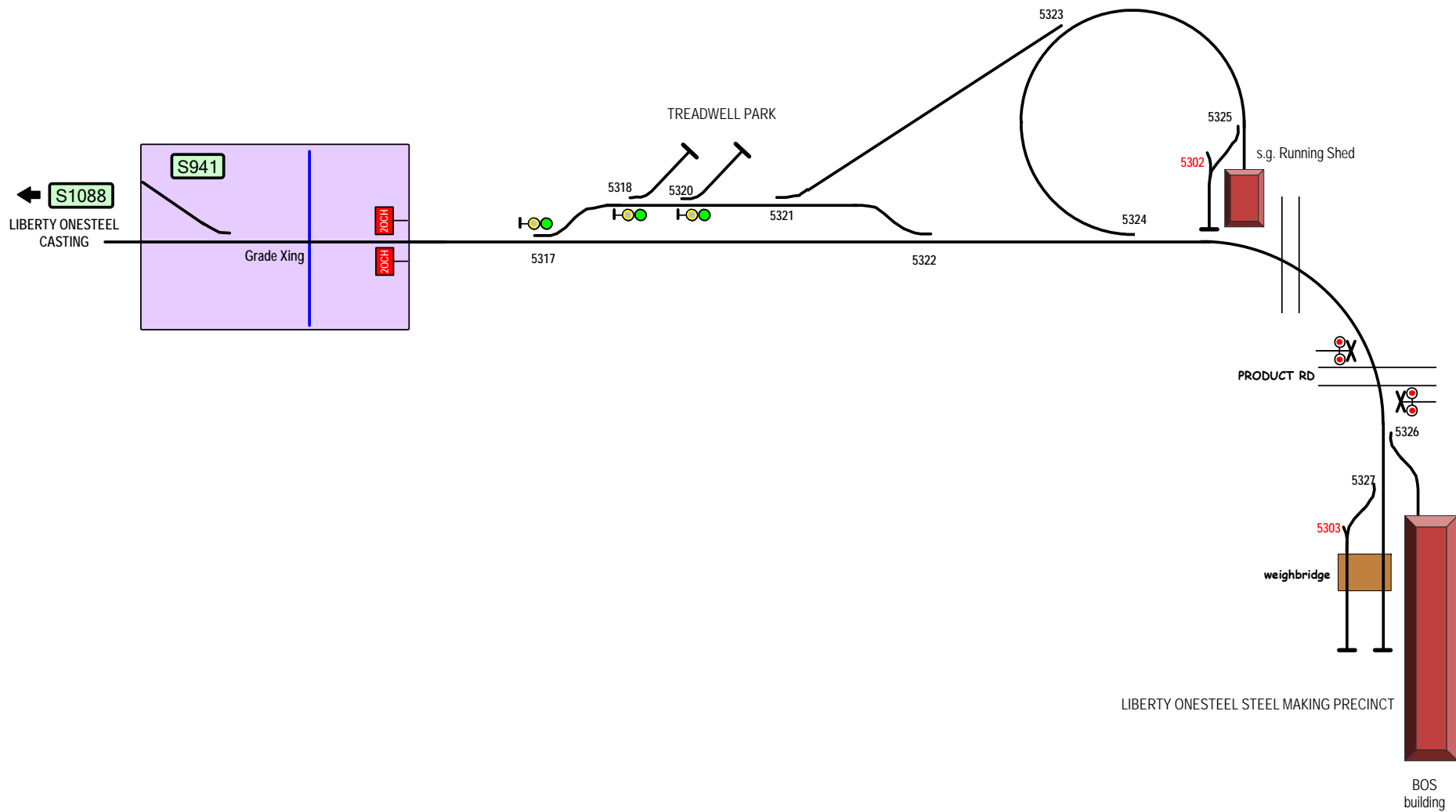

STANDARD GAUGE TRACK
LIBERTY ONESTEEL BOS - WHYALLA

LINES	Spencer Junction > Whyalla > Iron Duke
SECTION	Whyalla Environs
PAGES	941 - 943 & 1085 - 1089

South Australia

 Home

 Another SG Line

 Another NG Line

Click lines or yards to select

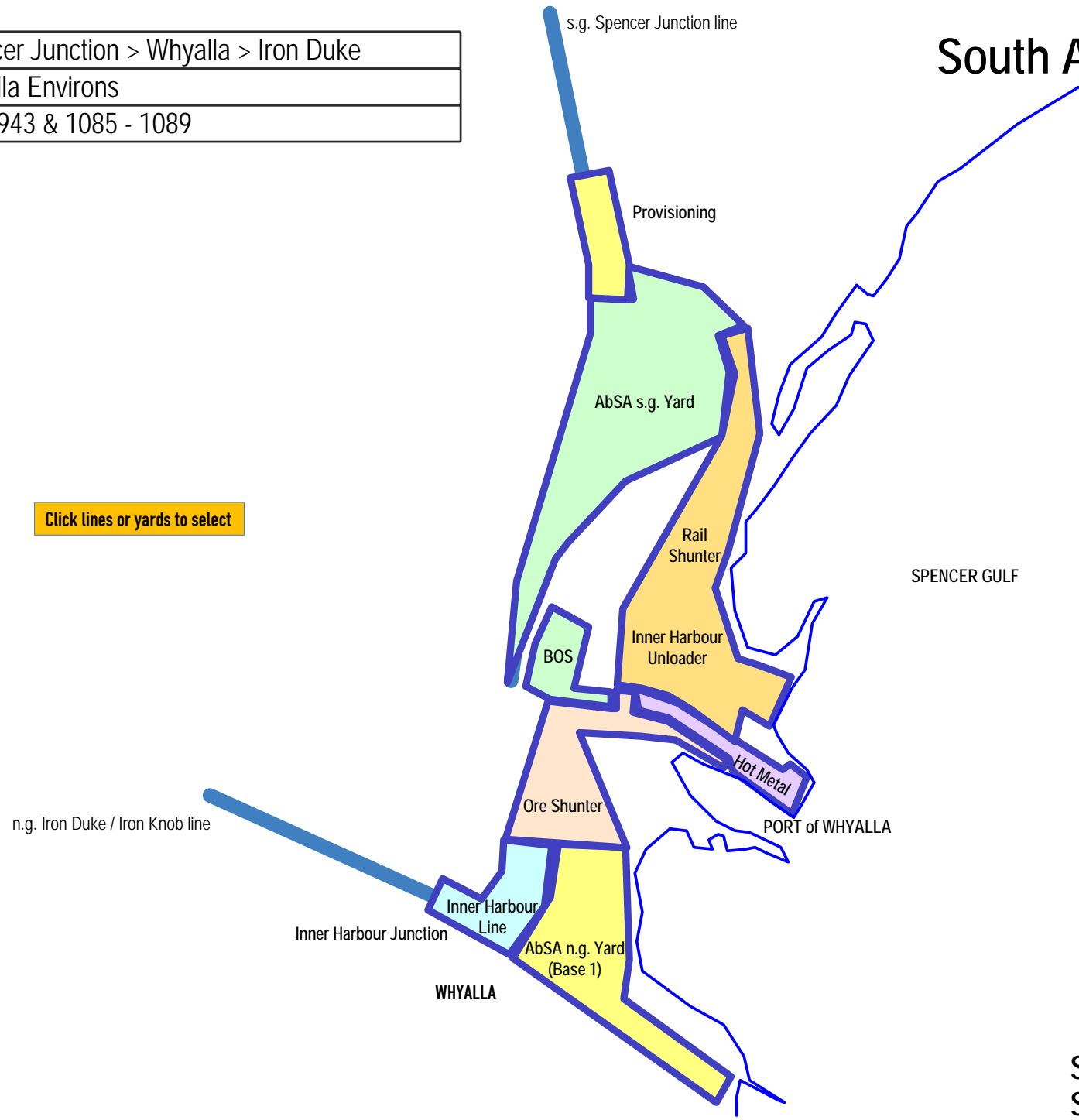

Section E2a
Section S2a

STOP BOARDS:

- SOA1: OBTAIN AUTHORITY ON CH66 FROM BASE 1 BEFORE PROCEEDING PAST THIS POINT
- SOAO: OBTAIN AUTHORITY ON CH67 FROM ORE SHUNTER BEFORE PROCEEDING PAST THIS POINT
- SOAH: OBTAIN AUTHORITY ON CH67 FROM HOT METAL SHUNTER BEFORE PROCEEDING PAST THIS POINT
- ZOCH: HOT METAL No2. OBTAIN CLEARANCE ON CH67 FROM HOT METAL SHUNTER BEFORE PROCEEDING PAST THIS POINT

WHYALLA INNER HARBOUR

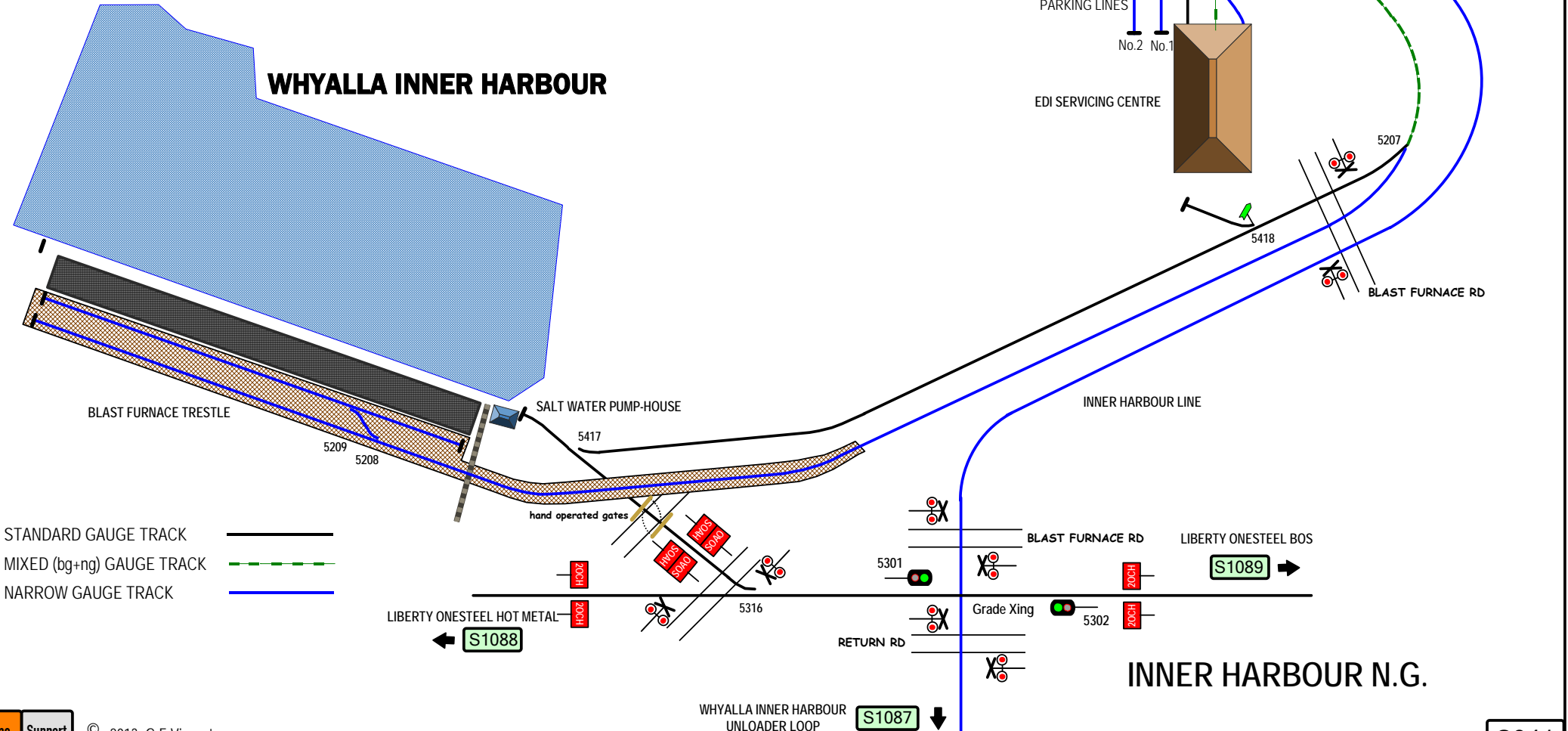

STANDARD GAUGE TRACK —————
 MIXED (bg+ng) GAUGE TRACK - - - - -
 NARROW GAUGE TRACK —————

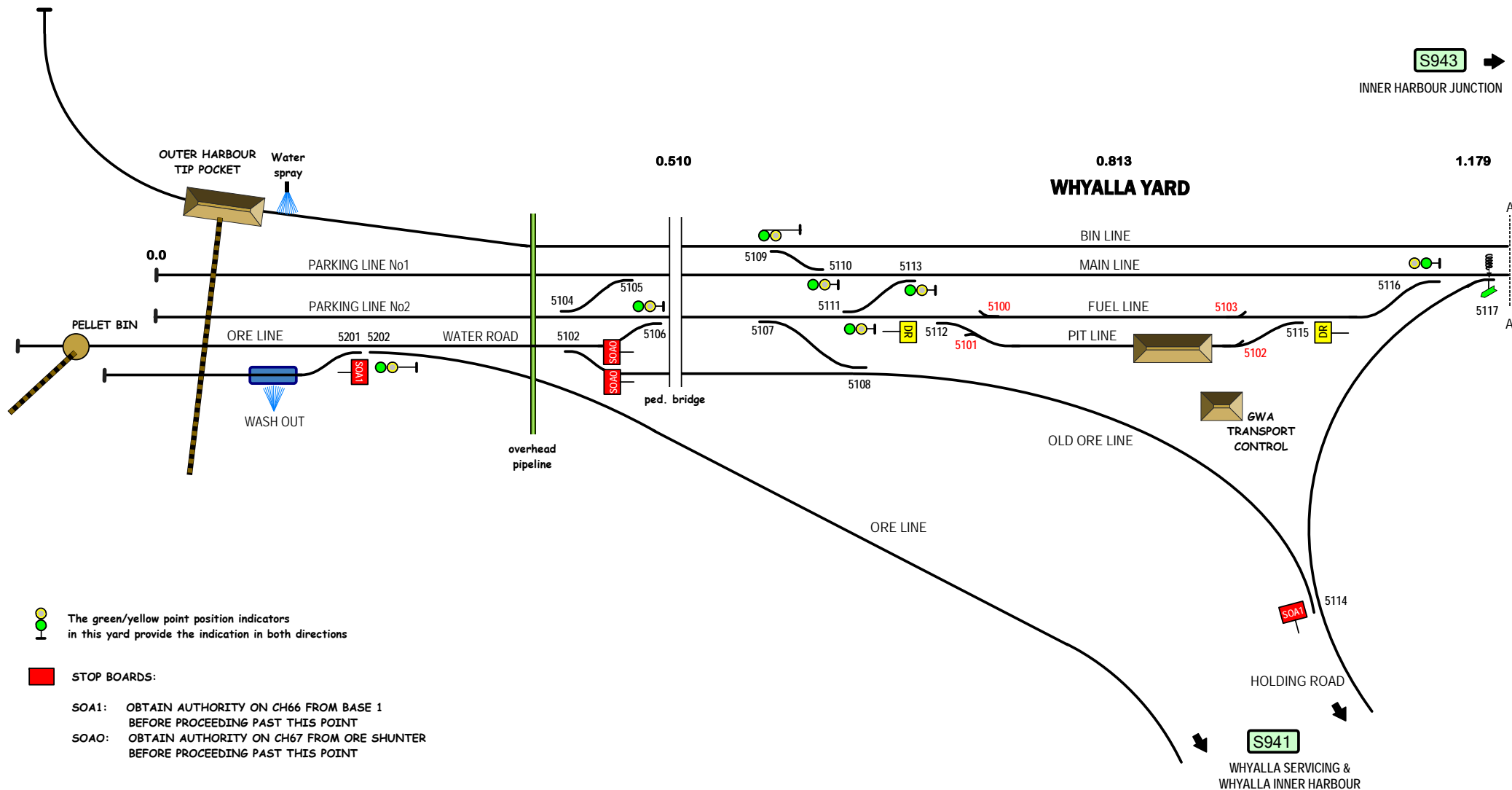

 The green/yellow point position indicators in this yard provide the indication in both directions

-  STOP BOARDS:
- SOA1: OBTAIN AUTHORITY ON CH66 FROM BASE 1 BEFORE PROCEEDING PAST THIS POINT
 - SOAO: OBTAIN AUTHORITY ON CH67 FROM ORE SHUNTER BEFORE PROCEEDING PAST THIS POINT

NARROW GAUGE TRACK
WHYALLA (SIMEC) N.G. TERMINAL

LINE	SIMEC Ore Line
SECTION	Whyalla - Iron Duke/IronKnob
PAGE	941 - 945

South Australia



▲ Home



■ Another Line

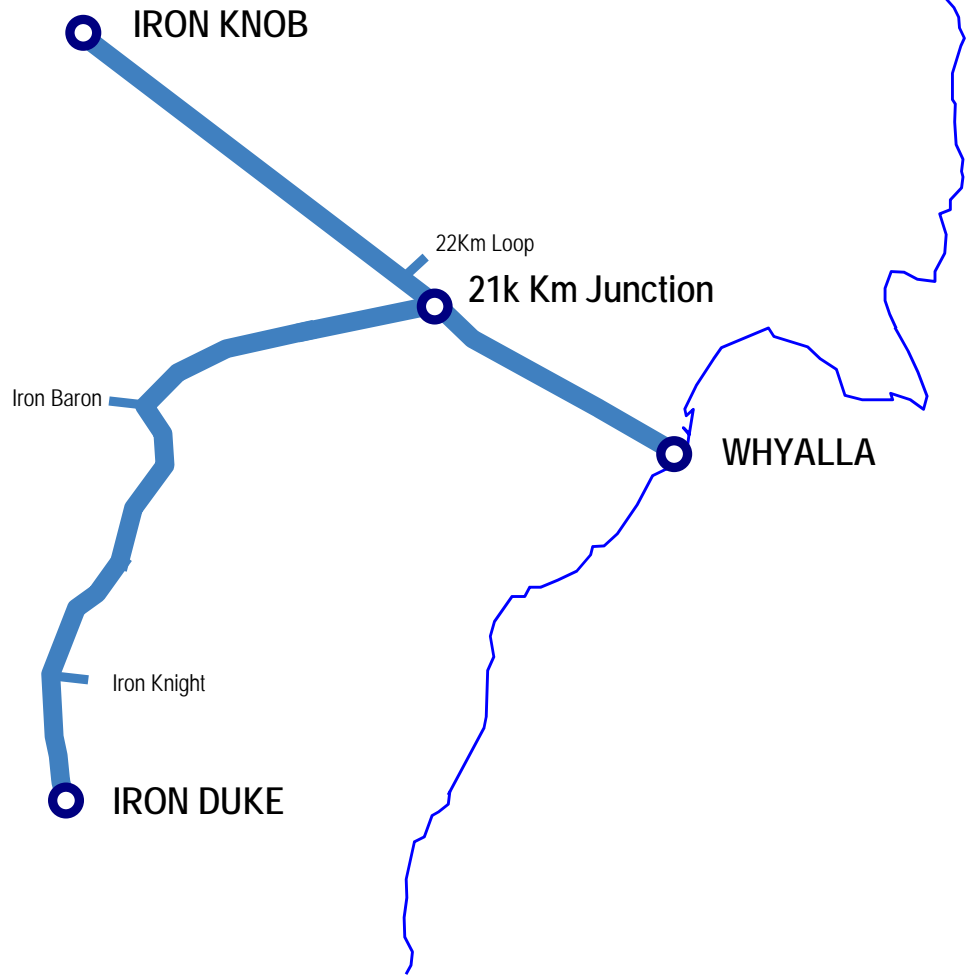

Click stations to select

 The blue/yellow point position indicators in this yard provide the indication in both directions

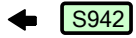
 S942

WHYALLA YARD

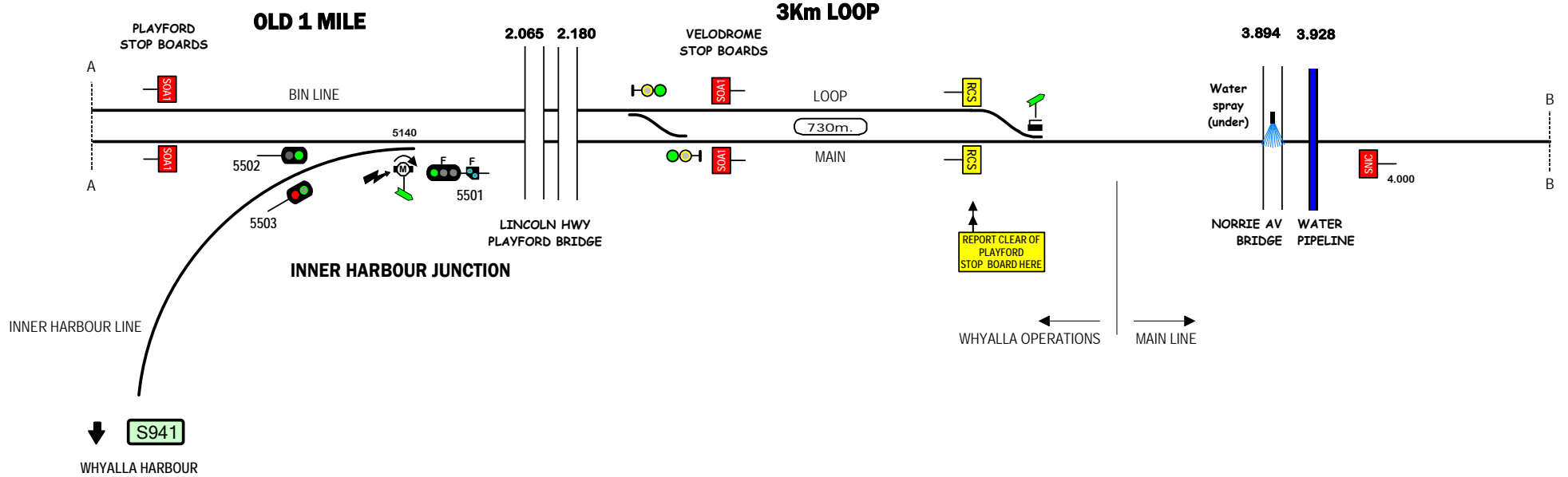

 S941

WHYALLA HARBOUR

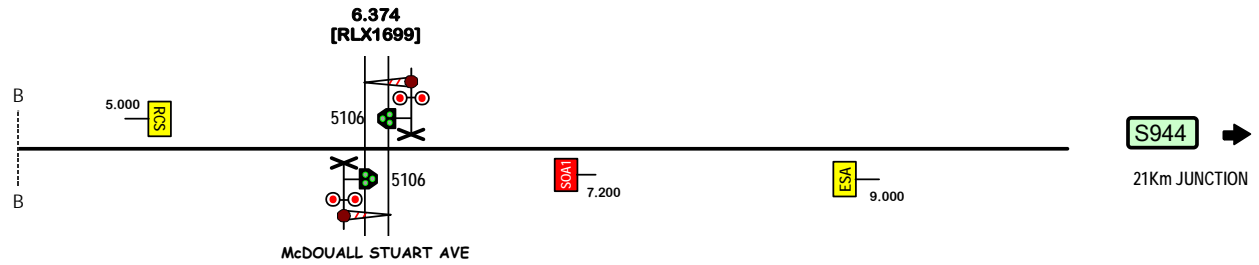

A conventional 'normally black' NSW style shunt signal is mounted facing approaching trains. It which shows 3 'greens' as an indication of the correct operation of the crossing functions.

NARROW GAUGE TRACK
WHYALLA WEST

- STOP BOARDS:**
- SOA1: STOP: OBTAIN AUTHORITY FROM BASE 1 BEFORE PROCEEDING PAST THIS POINT
 - SINC: STOP HERE IF NOT CLEARED FOR NEXT SECTION

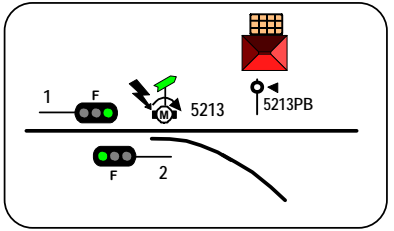
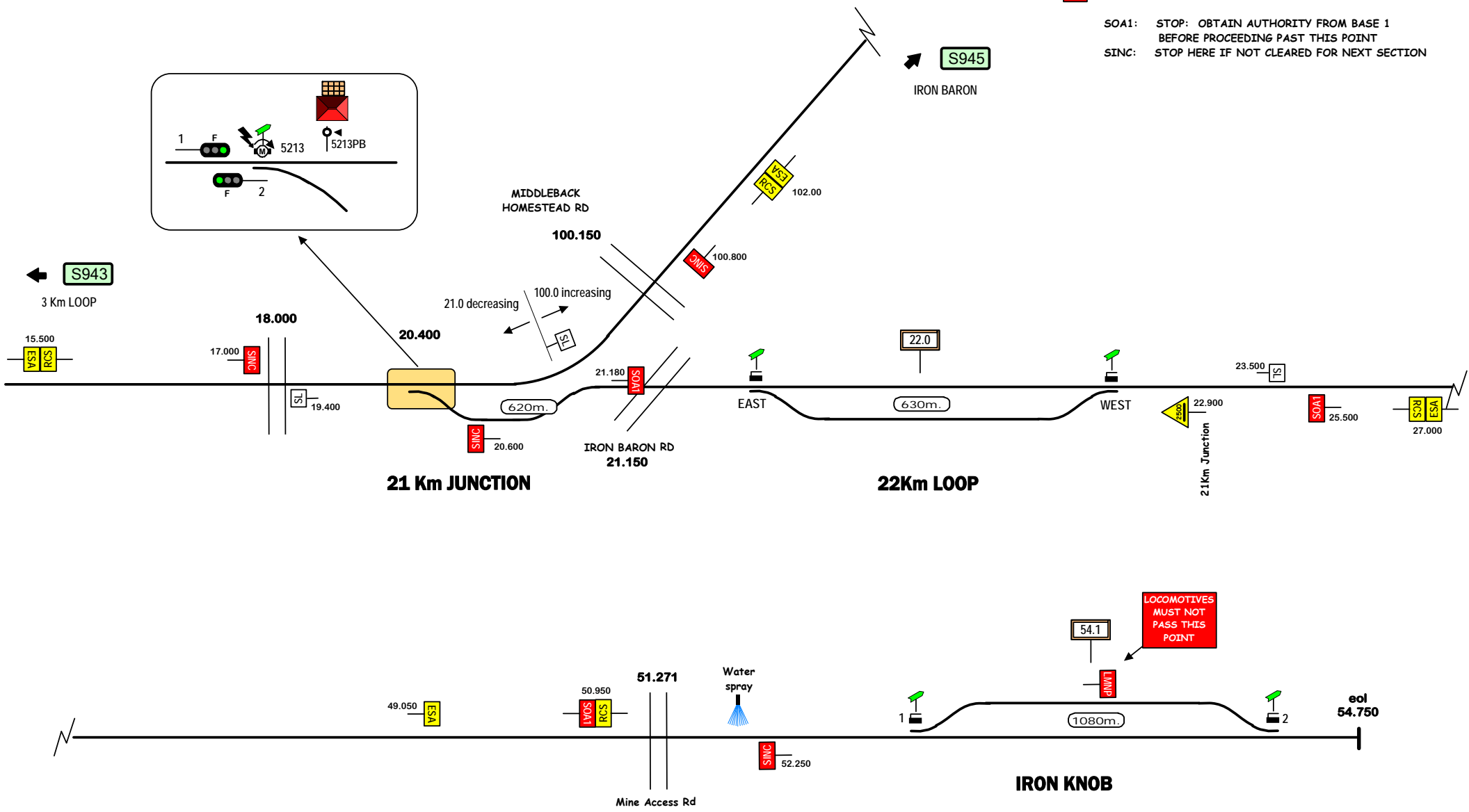

NARROW GAUGE TRACK
21Km JUNCTION - IRON KNOB

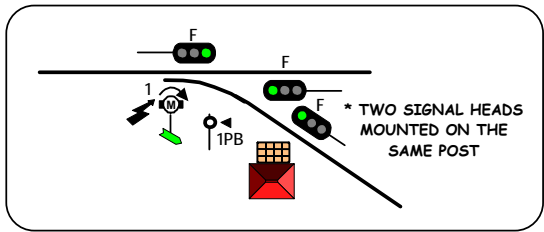
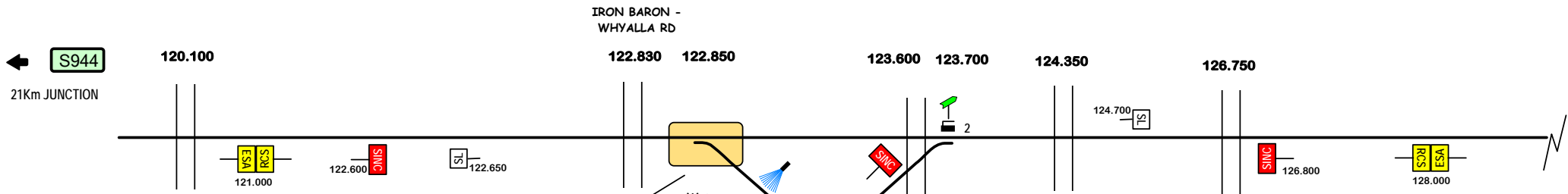

IRON BARON

LOCOMOTIVES MUST NOT PASS THIS POINT

(SINCLAIR'S GAP)

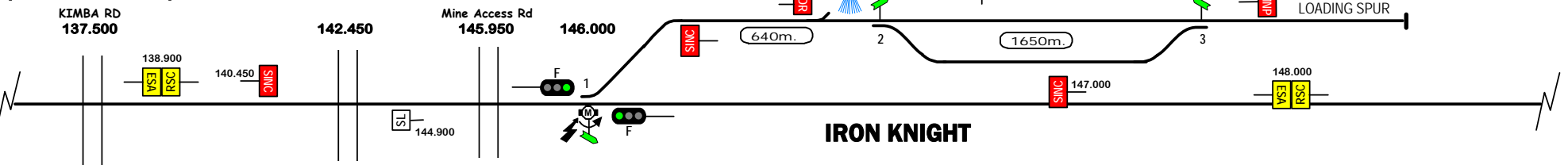

IRON KNIGHT

LOCOMOTIVES MUST NOT PASS THIS POINT

- STOP BOARDS:**
- SOA1: STOP: OBTAIN AUTHORITY FROM BASE 1 BEFORE PROCEEDING PAST THIS POINT
 - SINC: STOP HERE IF NOT CLEARED FOR NEXT SECTION

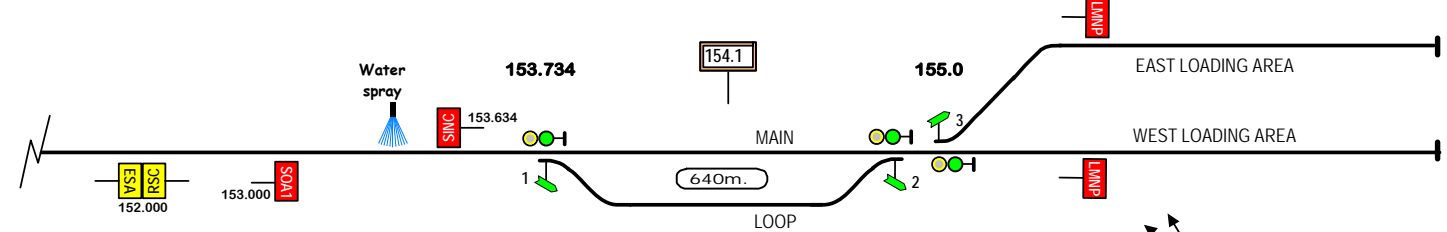

IRON DUKE

LOCOMOTIVES MUST NOT PASS THIS POINT

NARROW GAUGE TRACK
IRON BARON - IRON DUKE

LINE	Leigh Creek Coalfield Line & P.S Branch
SECTION	Stirling North - Bungala
PAGES	932



▲ Home



■ Another Line

For reference to the abandoned section contact gh.vince@bigpond.net.au reference **93x**

Click stations to select

South Australia

ex LEIGH CREEK COALFIELD

Copley
Puttapa

Parachilna

Cotabena BP
Curently Unused

Neuroodla

Wilkatana

ex NORTHERN POWER STATION

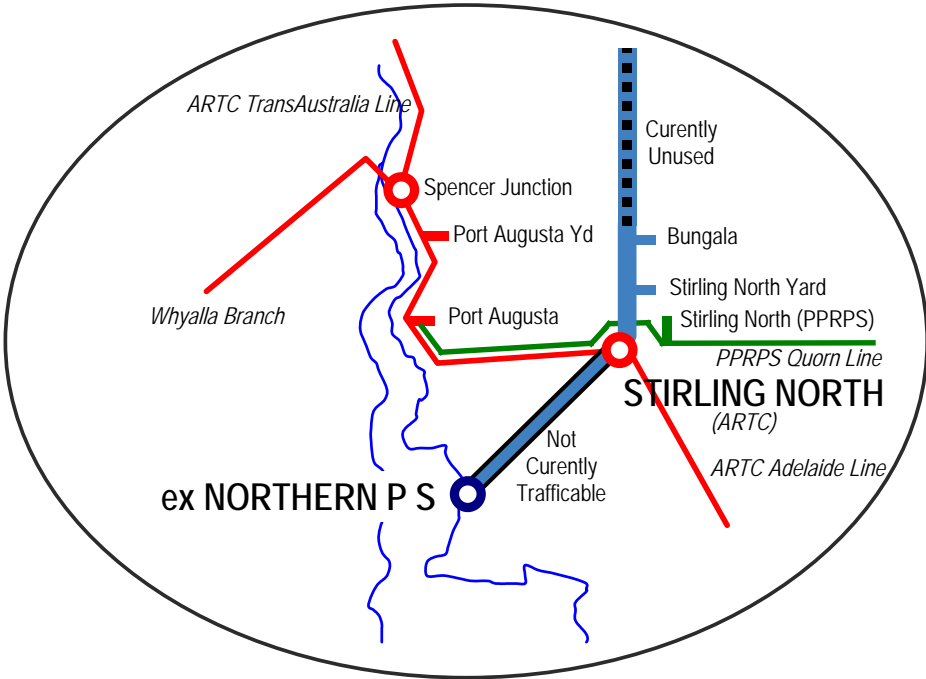

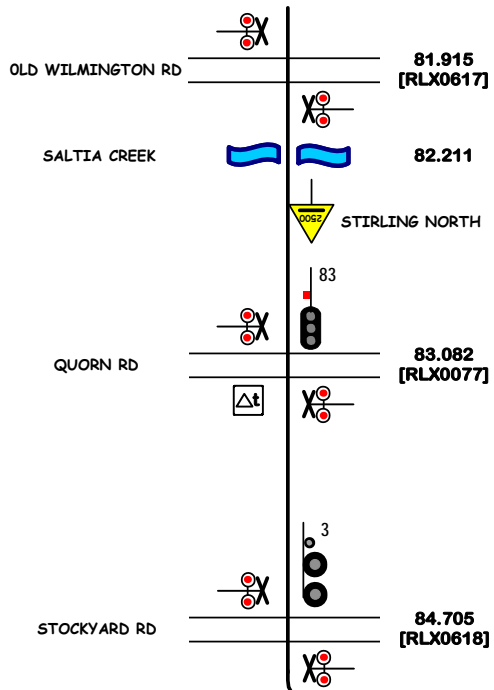

↑ S082
WINNINOWIE

STIRLING NORTH (& YARD) -
BENGALA
on one page

START TRAIN ORDER WORKING LEIGH CREEK LINE	START CTC WORKING TO WINNINOWIE
--	---

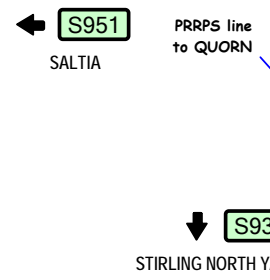
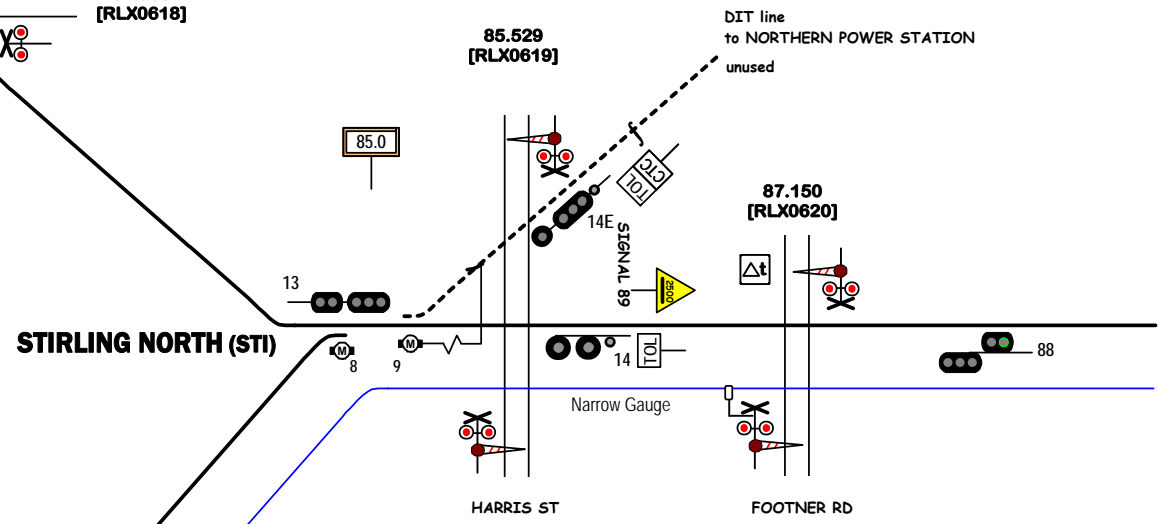

↑ START
TRAIN ORDER
WORKING
LEIGH CREEK
LINE

STANDARD GAUGE TRACK except as shown
STIRLING NORTH

Signal Locations

Home Support

© 2008 G F Vincent

S083

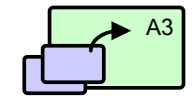

STIRLING NORTH (& YARD) -
BENGALA
on one page

← **S083**

STIRLING NORTH
JUNCTION

85.450 85.550

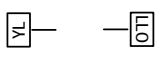

85.992

~ 1660m.

86.466

725m.

87.475

560m.

450m.

LIMIT OF
LOCOMOTIVE
OPERATION
WHEN LINE
IS CLOSED

STIRLING NORTH YARD

Wagon graveyard

88.037

88.080

93.803

94.804



95.800

DPTI line
to LEIGH CREEK COALFIELD
closed

STIRLING NORTH

→ WILKATANA

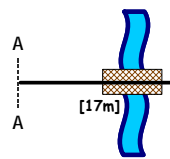

MUNDALLIO CK

WARRAKIMBO RD

WARRAKIMBO RD

unnamed

BUNGALA

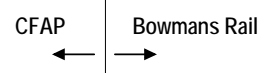

STANDARD GAUGE TRACK

STIRLING NORTH YARD - BUNGALA

LINE	Mid North & Murray Mallee Lines
SECTION	All
PAGES	901, 911, 912

South Australia

For reference to Central or Murray Mallee lines
closed in recent years
contact gh.vince@bigpond.net.au
reference **91x**

LINE	Darwin Line
SECTION	Northgate - Alice Springs - Berrimah
PAGES	1811 - 1825



▲ Home



■ Another Line

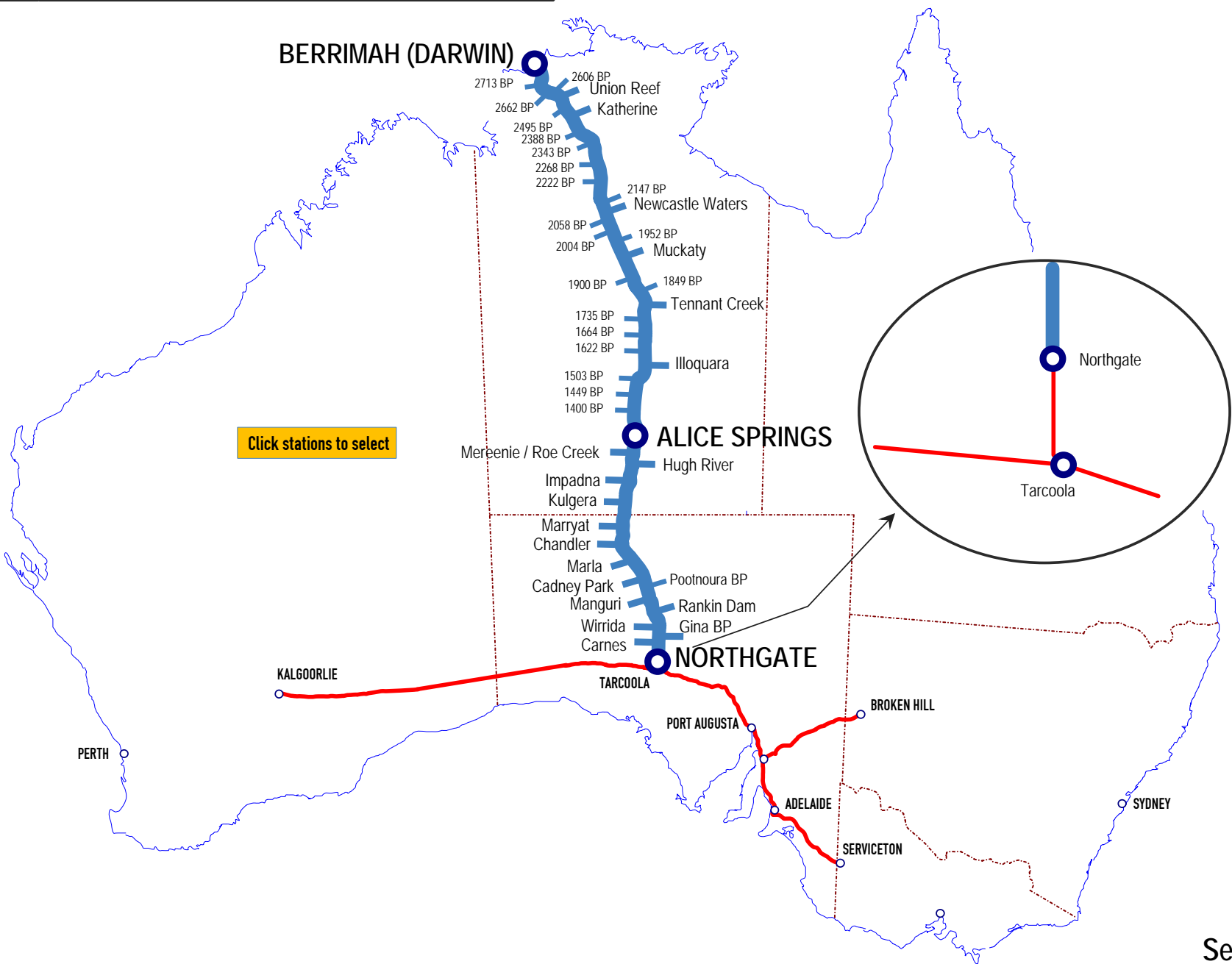

Click stations to select

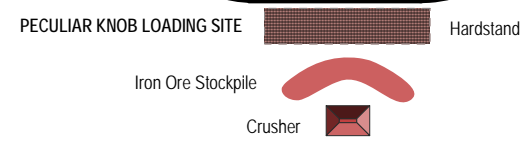
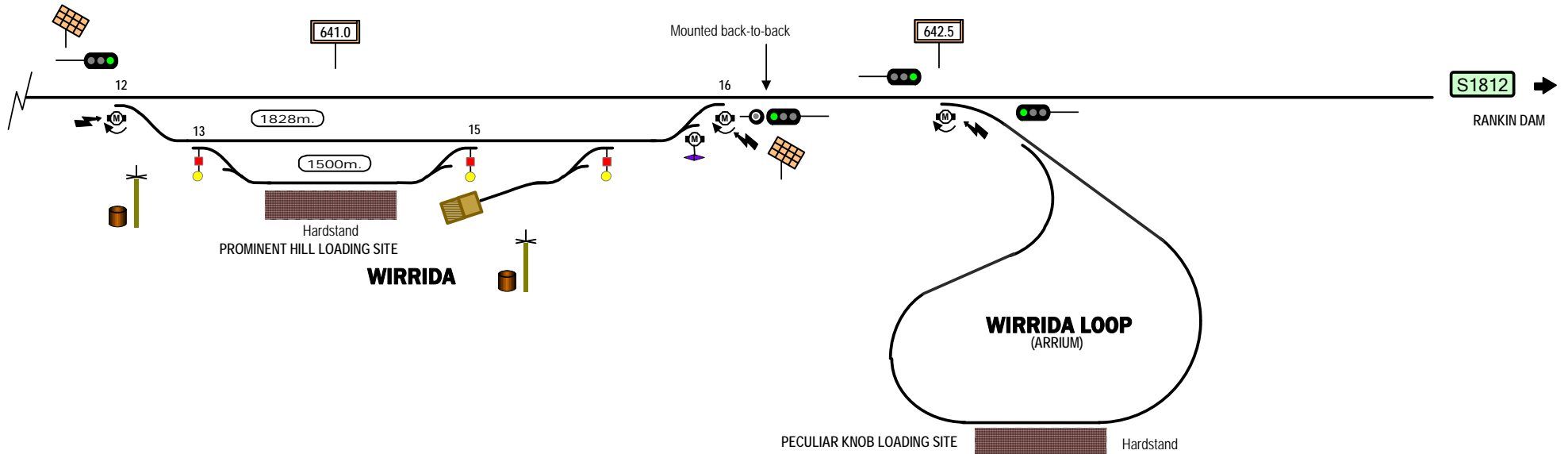
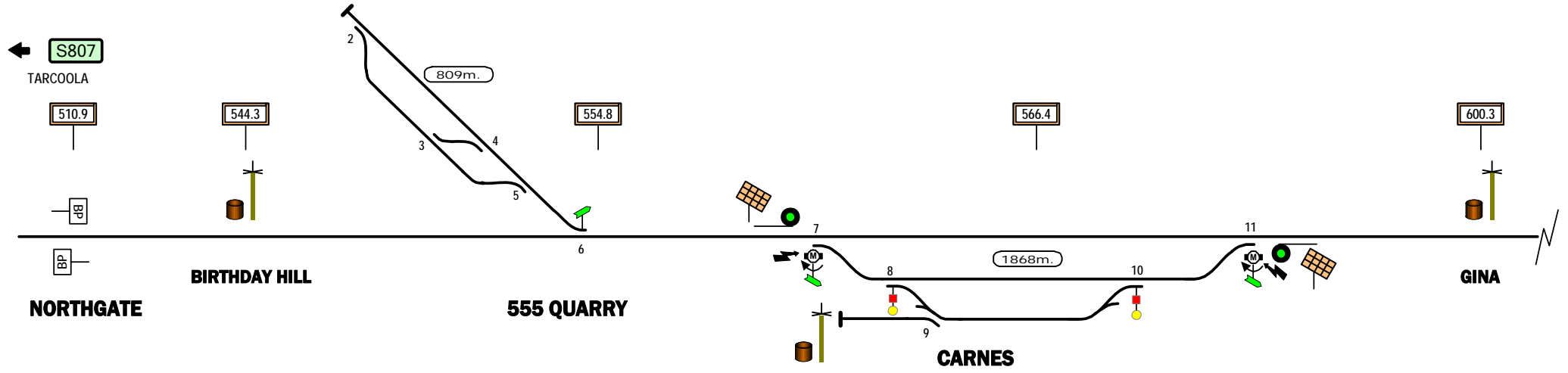

STANDARD GAUGE TRACK
NORTHGATE - WIRRIDA

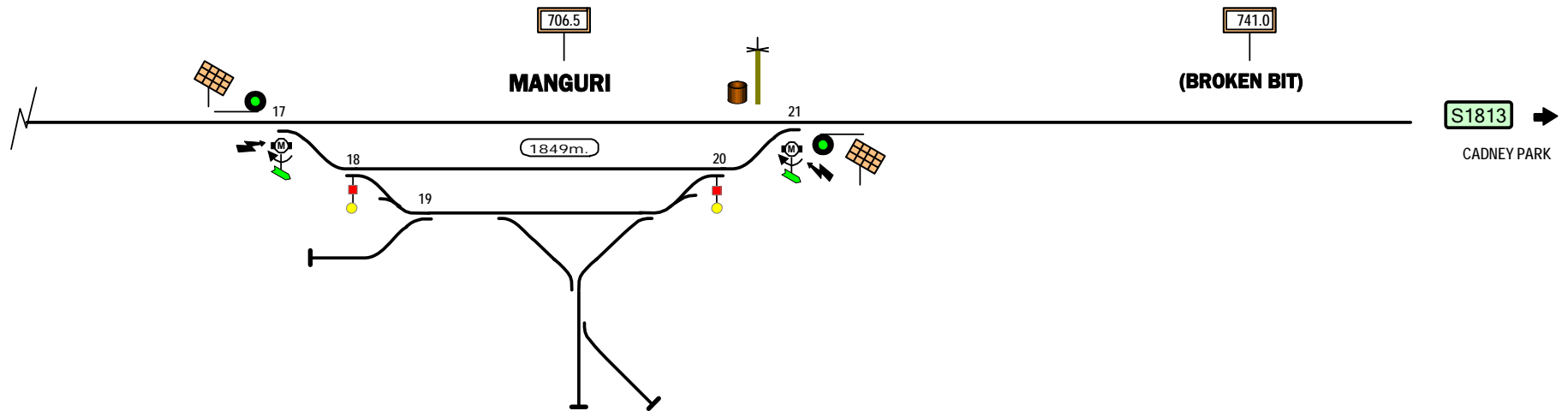
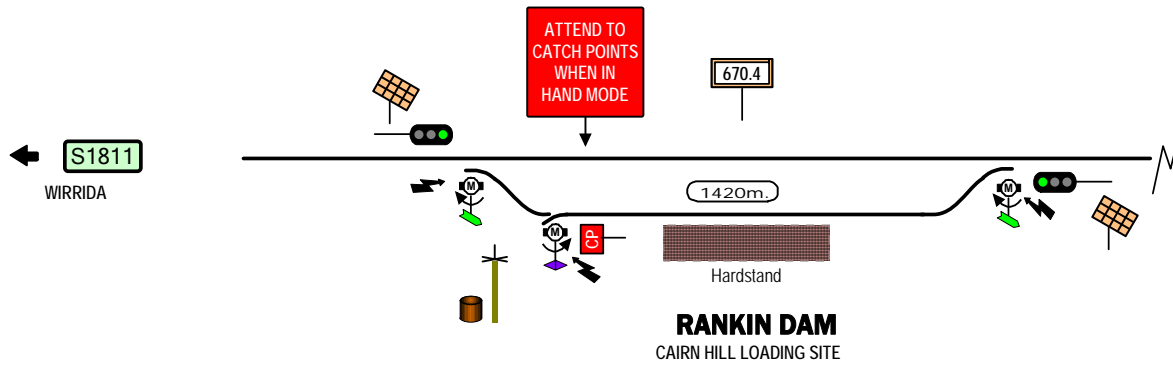

STANDARD GAUGE TRACK
RANKIN DAM - MANGURI

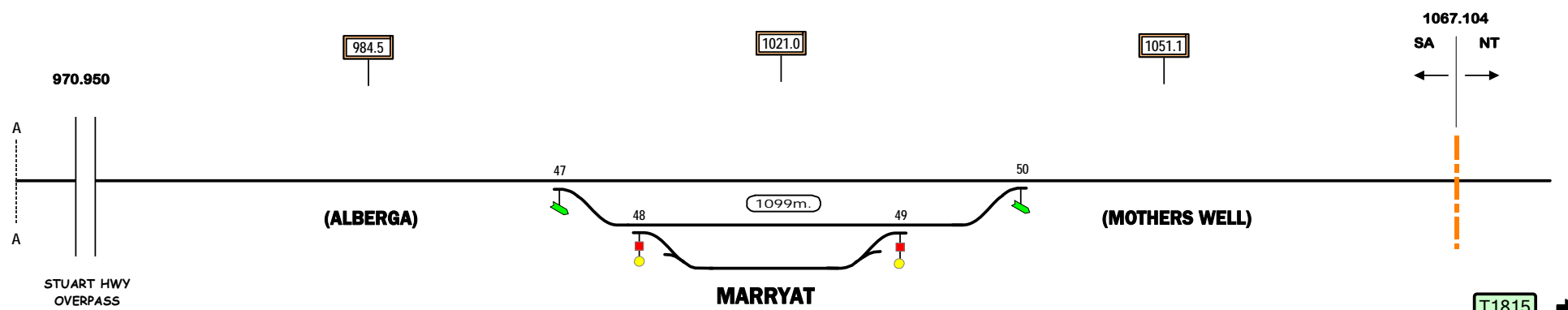
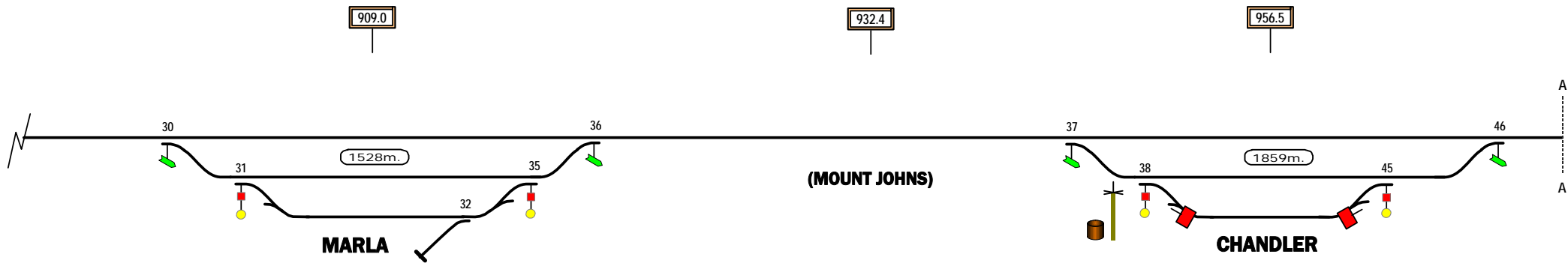
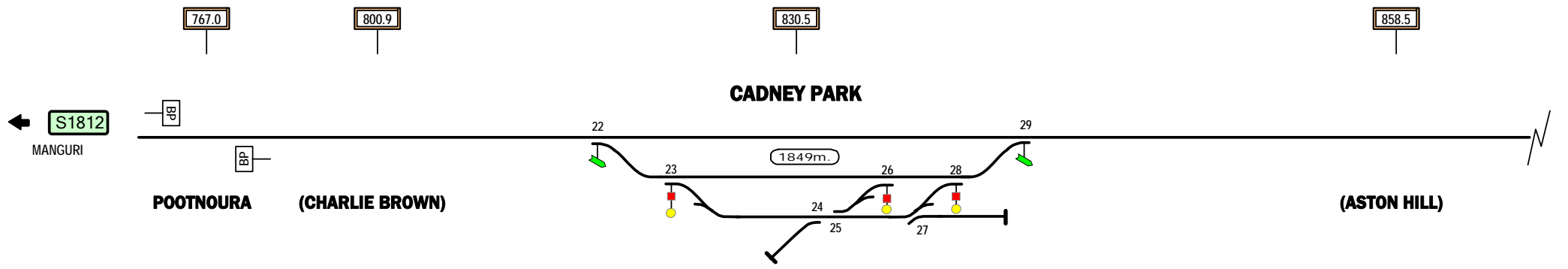

STANDARD GAUGE TRACK
CADNEY PARK - MARRYAT

T1815 →
 KULGERA

S1813

S1813

MARRYAT

1067.104

SA

NT

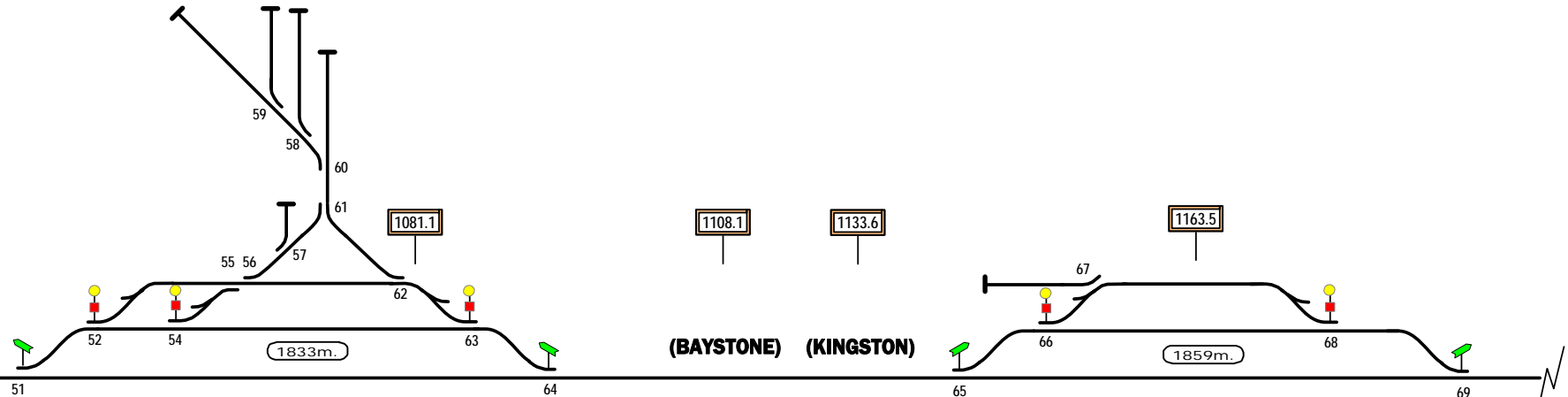
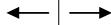

KULGERA

(BAYSTONE) (KINGSTON)

IMPADNA

1170

1196.4

1222.8

1244.5

1276.8

1301.4

1313.0

1192.0

IRON MAN MONUMENT



FINKE RIVER



(HELL'S GATE) (AGER'S REST)

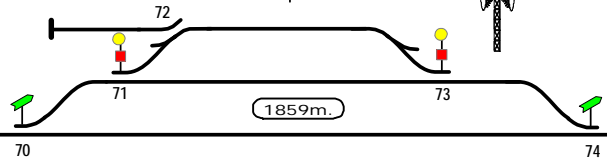

HUGH RIVER

(DINGO) (MAGELLAN)

MEREENIE

1318.0

1322.942

1327.2

1329.250

1331.810

1332.020

1333.900

1334.500

1888m

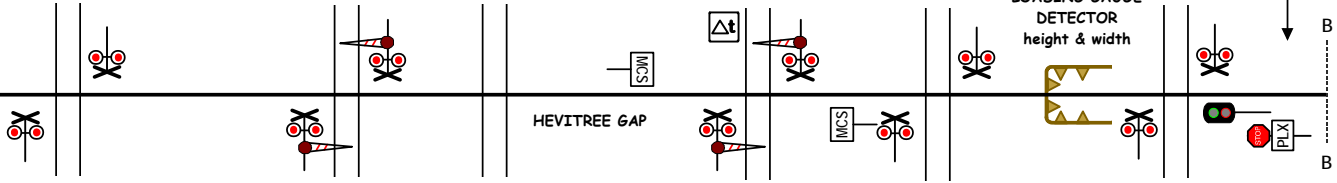

(McDONNELL)

(ALICE SPRINGS)

OPERATE LEVEL CROSSING PROTECTION BY MANUAL PUSH BUTTON. PROCEED ONLY AFTER LEVEL CROSSING PROTECTION OBSERVED TO BE OPERATING AND ROAD TRAFFIC STOPPED

LOADING GAUGE DETECTOR height & width

ROE CREEK

STANDARD GAUGE TRACK SA BORDER - (ALICE SPRINGS)

T1817

ALICE SPRINGS

T1815

Home Support

© 2013 G F Vincent

B-----B

T1815
ROE CREEK

ALICE SPRINGS

Low Level Platform



585m.

No 1 (Ghan) Road

MAIN

890m.

No 2 Road

No 3 Road

C

C

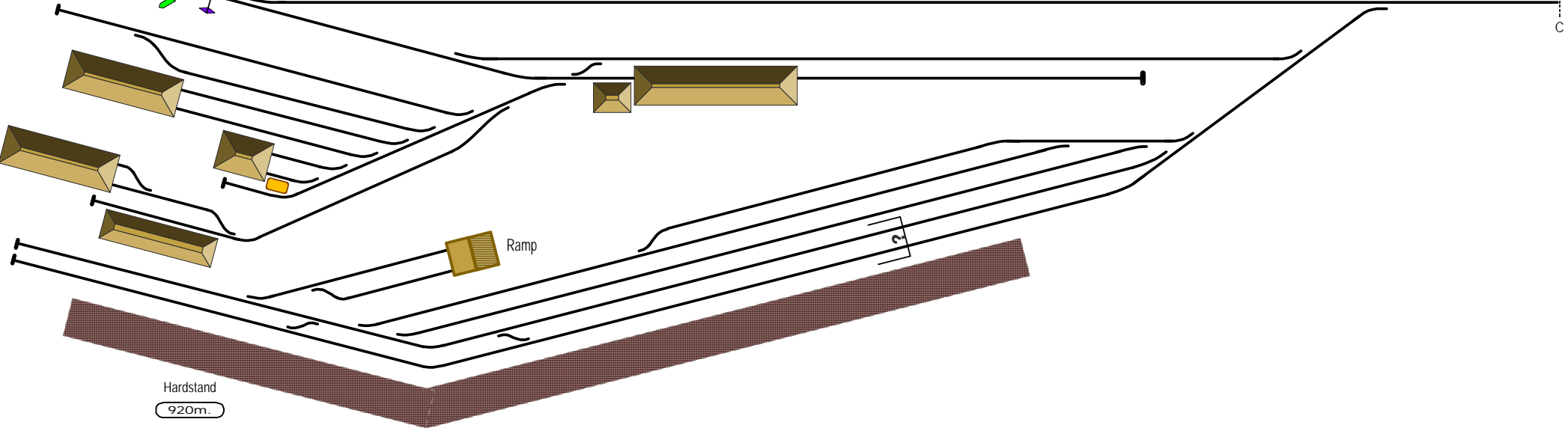

Hardstand
920m.

1337.000

MAIN

C

MAIN

C

LOVEGROVE DRV

Origin Energy PLG siding

T1819
ILLOQUARA

Caltex siding

STANDARD GAUGE TRACK
ALICE SPRINGS

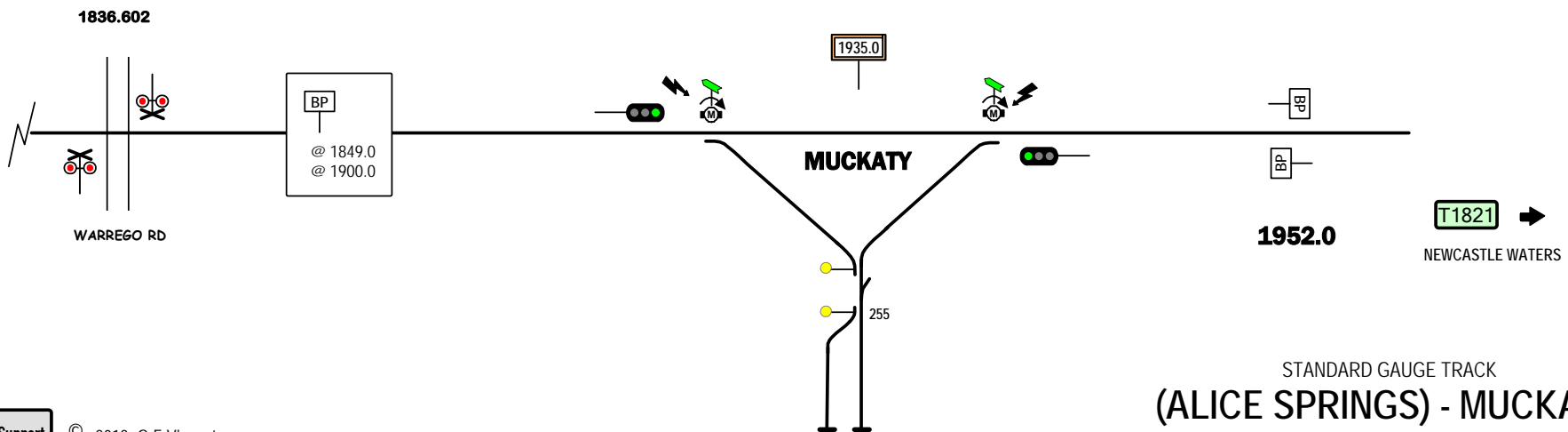
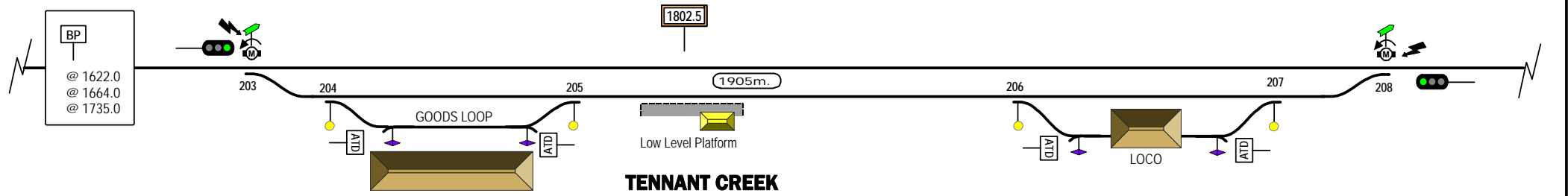
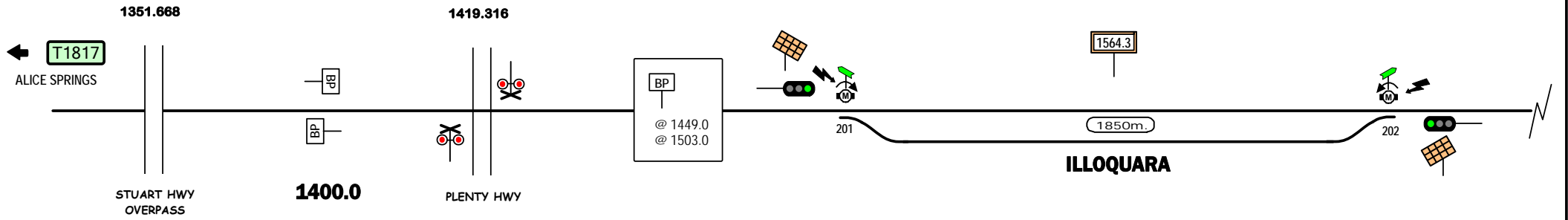

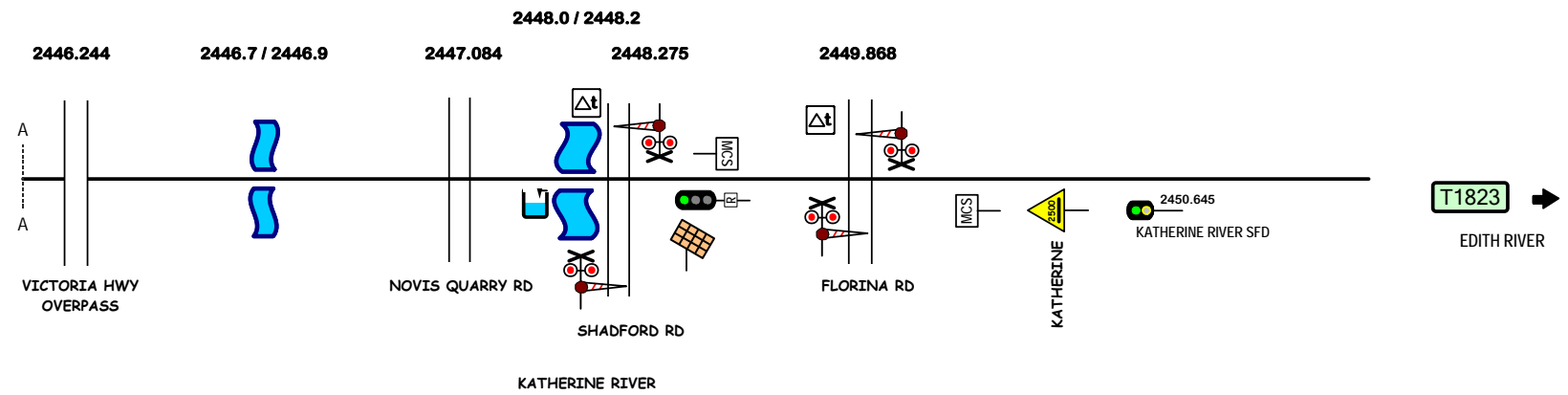
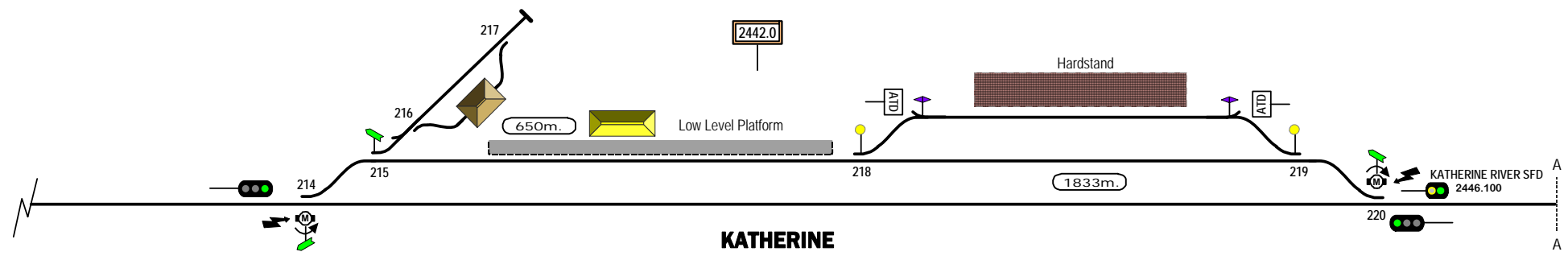
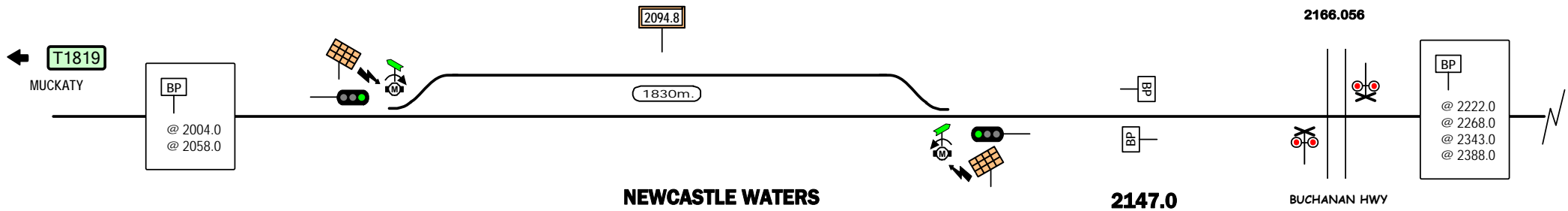

STANDARD GAUGE TRACK
NEWCASTLE WATERS - KATHERINE

T1821

KATHERINE

2490.325

2490.749

2505.760

2510.996

2534.896

2538.572

EDITH RIVER SFD
2488.050

BP
FERGUSON RIVER SFD
2501.150

CULLEN RIVER SFD
2507.990

2493.272
EDITH RIVER SFD

BP

2508.010
FERGUSON RIVER SFD

2513.683
CULLEN RIVER SFD

EDITH FALLS RD

EDITH RIVER

2495.0

FERGUSON RIVER

CULLEN RIVER

BONROOK ACCESS

KAKADU HWY
(PINE CREEK)

2549.917

2553.7

1930m

Hardstand - Ore loading

UNION REEF

2606.0

T1824

ADELAIDE RIVER

STANDARD GAUGE TRACK

EDITH RIVER - UNION REEF

Home Support

© 2013 G F Vincent

T1823

← T1823

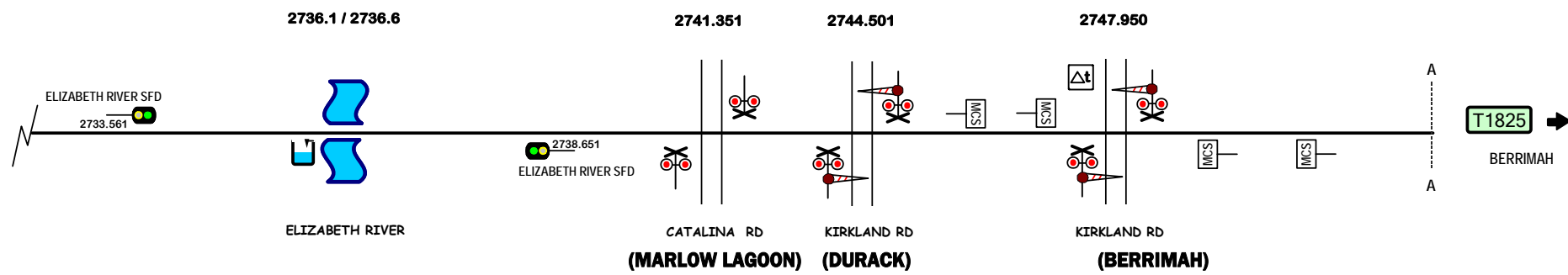
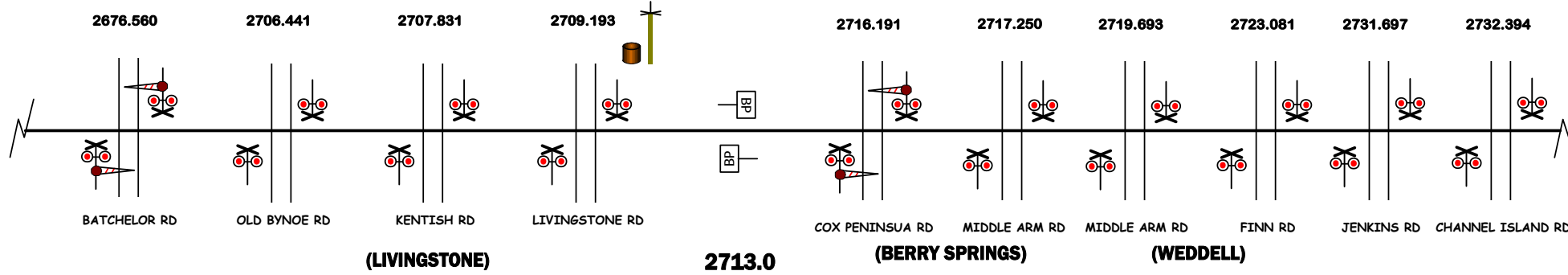
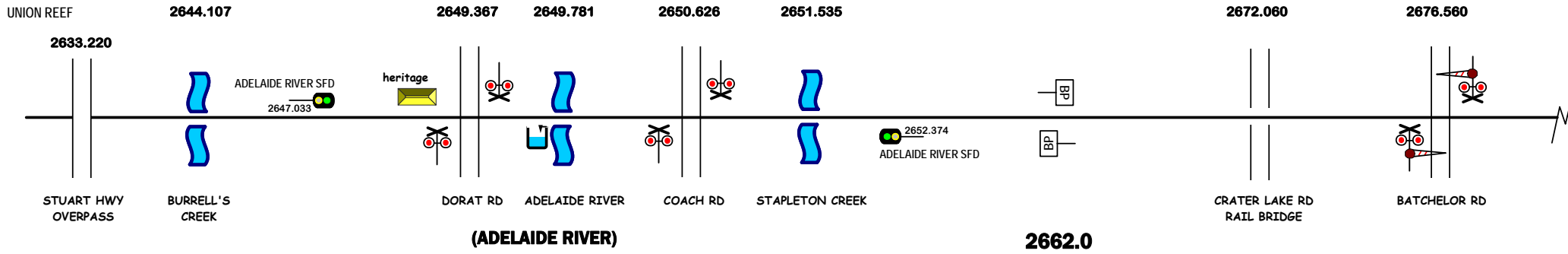

STANDARD GAUGE TRACK
 (ADELAIDE RIVER) - (BERRIMAH)

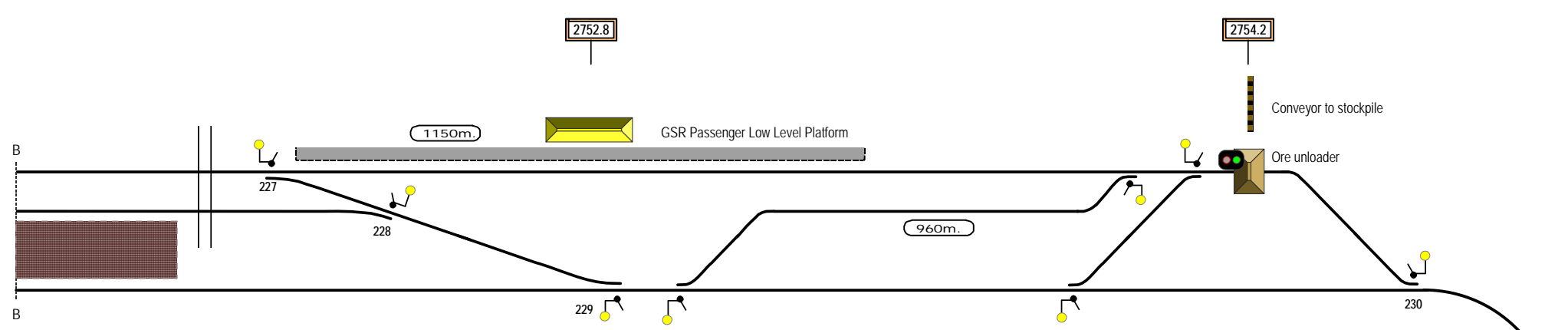
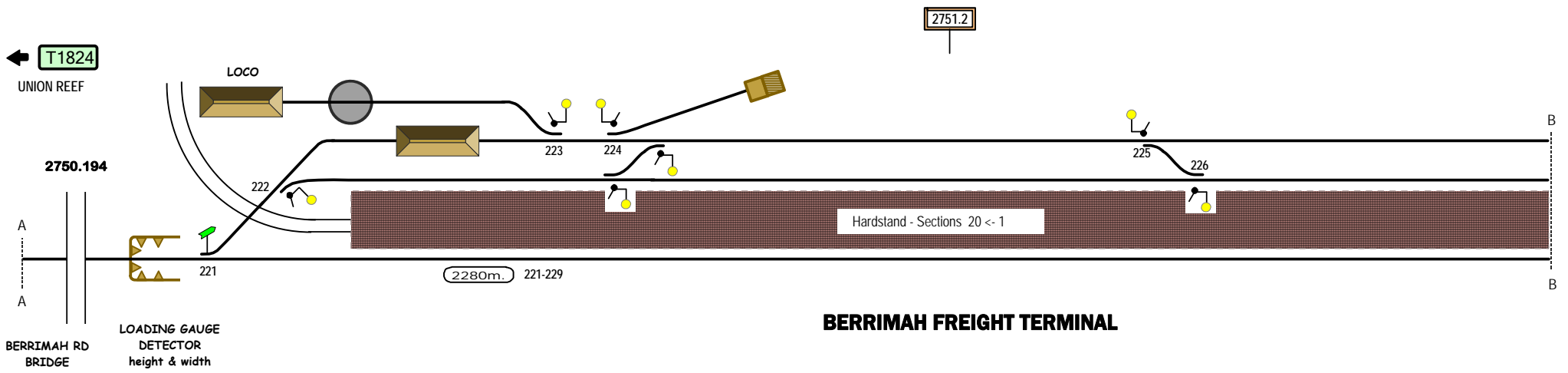

 All turnouts in this yard (except 221) are lever controlled trailable switches with attached yard-type low level target indicators

LINE	Pichi Richi Preservation Society Line
SECTION	Port Augusta - Quorn
PAGES	951 - 952

South Australia



▲ Home



■ Another Line

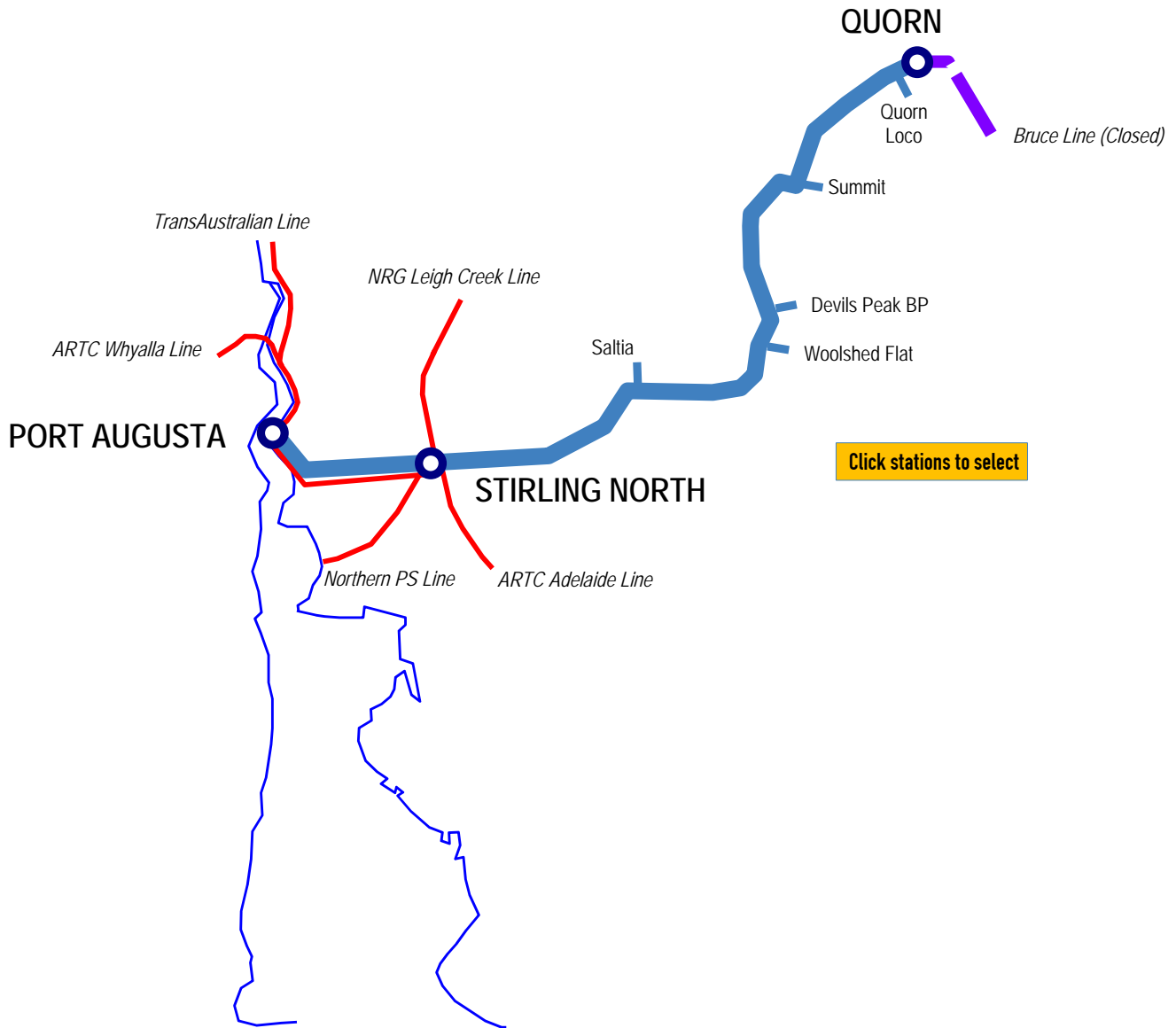

Click stations to select

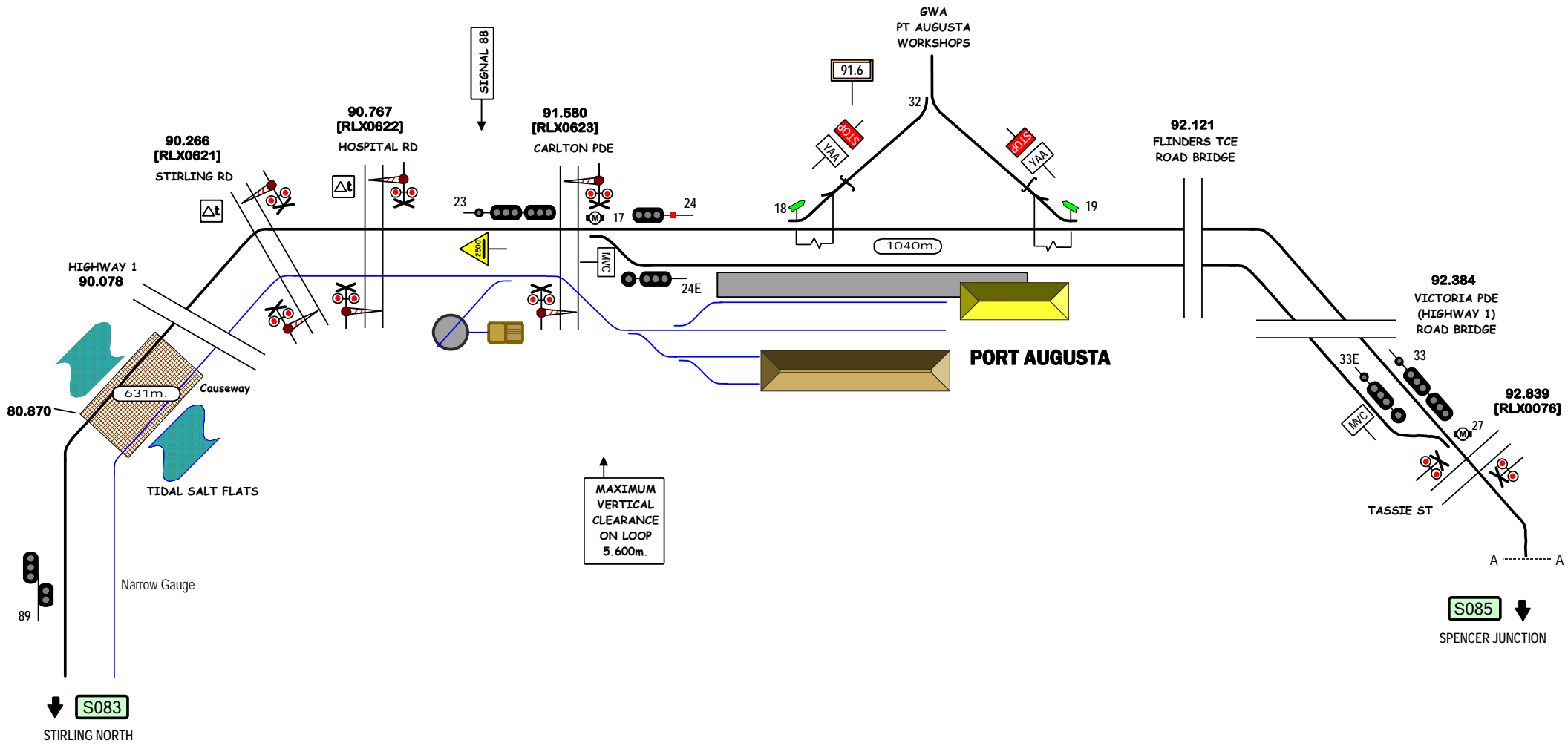

Signal Locations	
Home	Support

© 2009 G F Vincent

STANDARD GAUGE TRACK except as shown
PORT AUGUSTA

S084

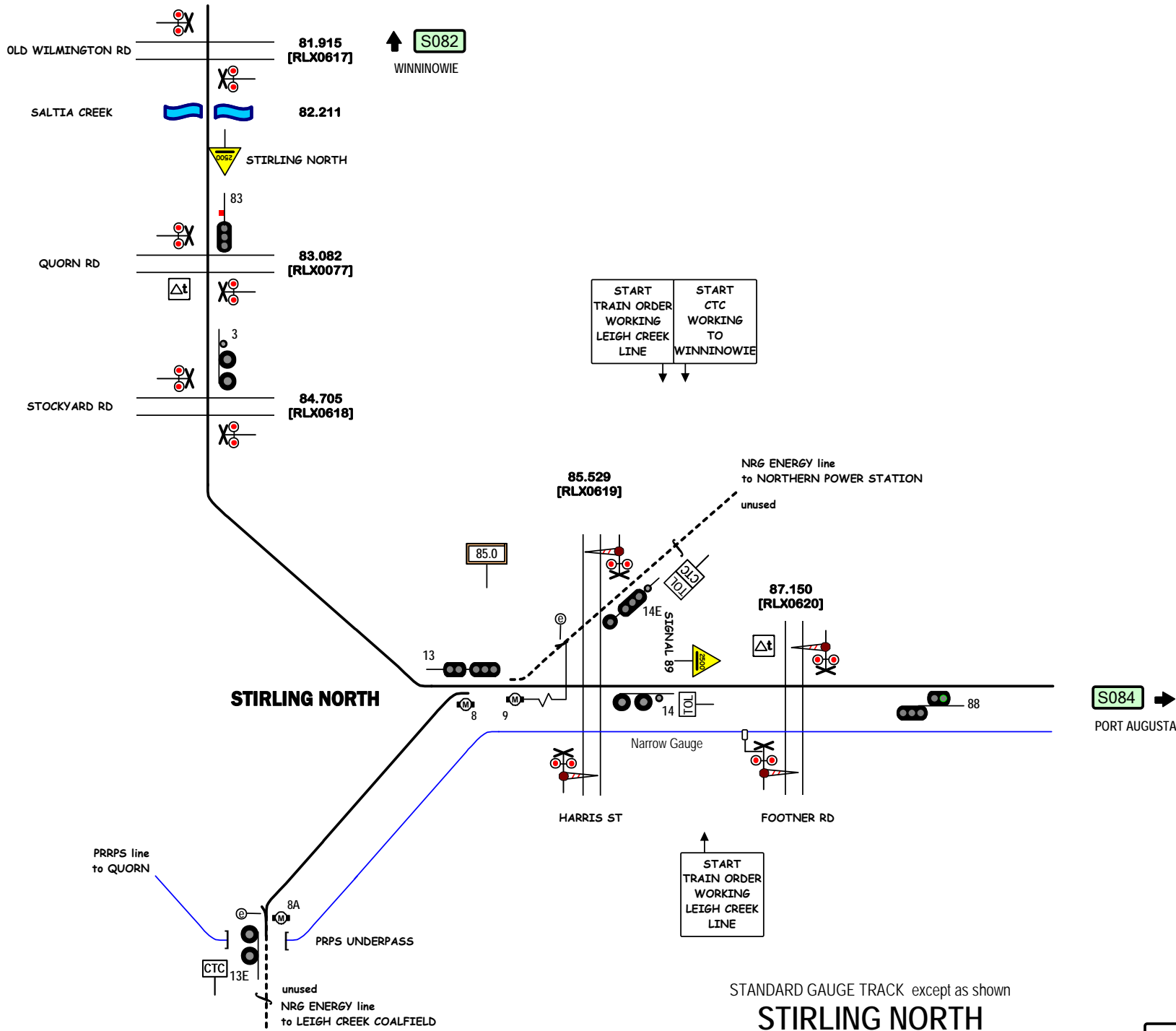

STIRLING NORTH

STANDARD GAUGE TRACK except as shown
STIRLING NORTH

Signal Locations
 Home Support

← S083
STIRLING NORTH (s.g.)

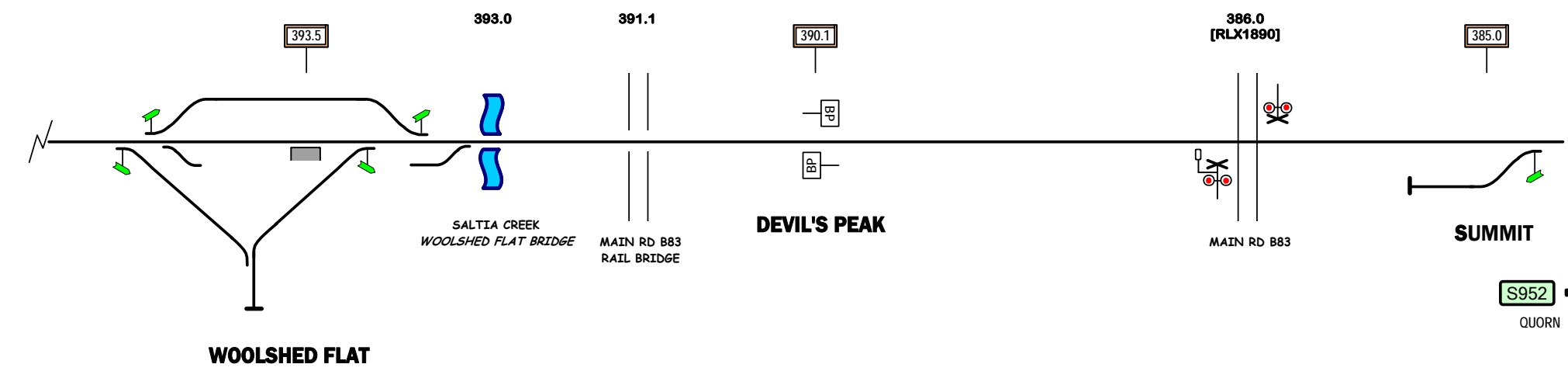
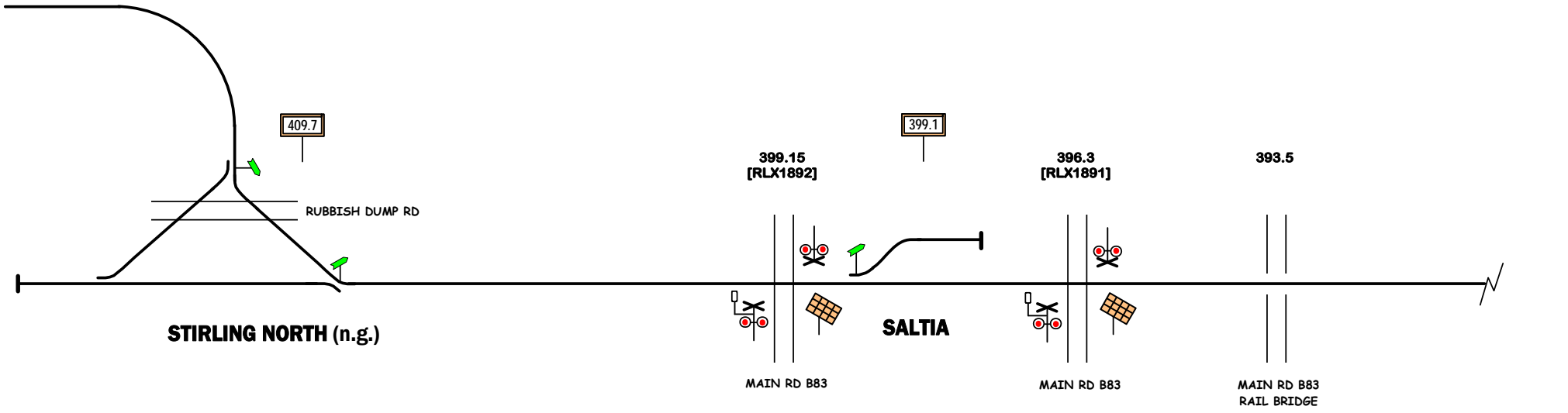

S952 →
QUORN

NARROW GAUGE TRACK STIRLING NORTH - SUMMIT

378.172

377.387

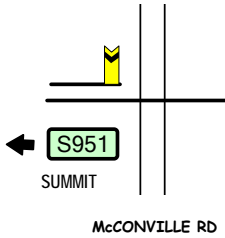
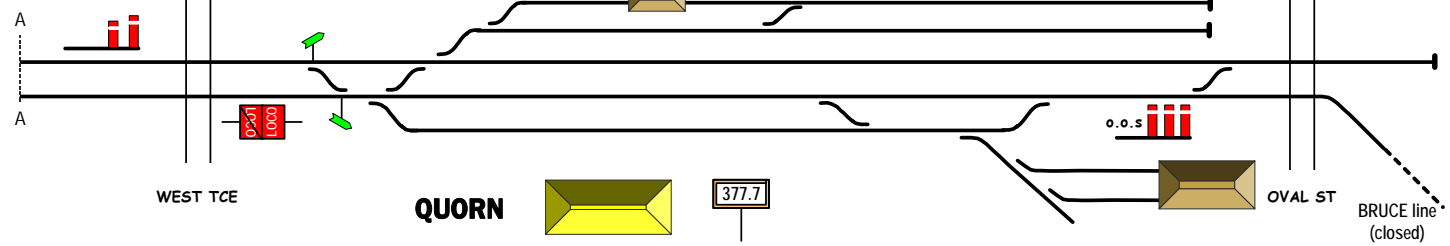

378.938

378.7

378.586

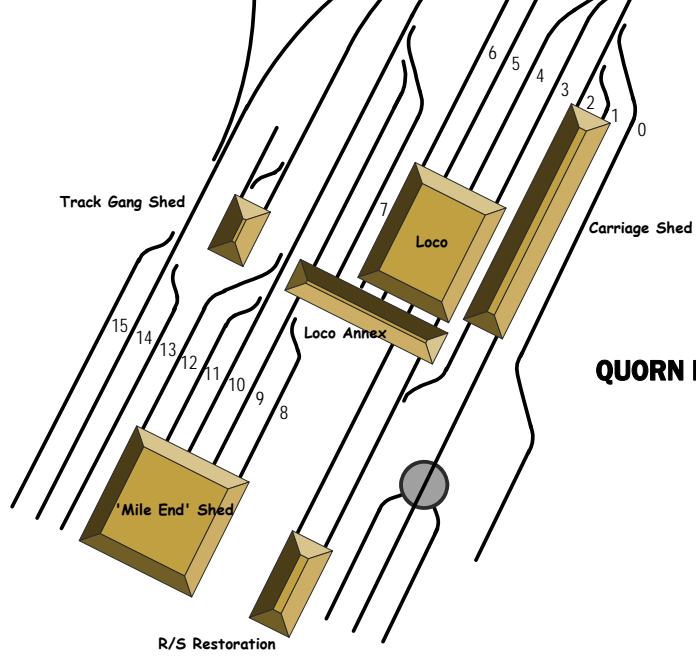
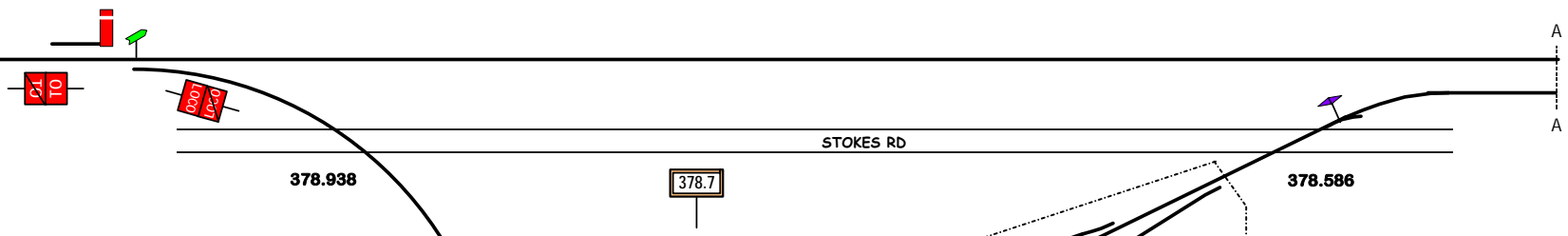

NARROW GAUGE TRACK
QUORN

Pichi Richi Railway Preservation Society



LINE	SteamRanger Heritage Line
SECTION	Mount Barker Junction - Victor Harbor
PAGES	953 - 956

South Australia

▲ Home

■ Another Line

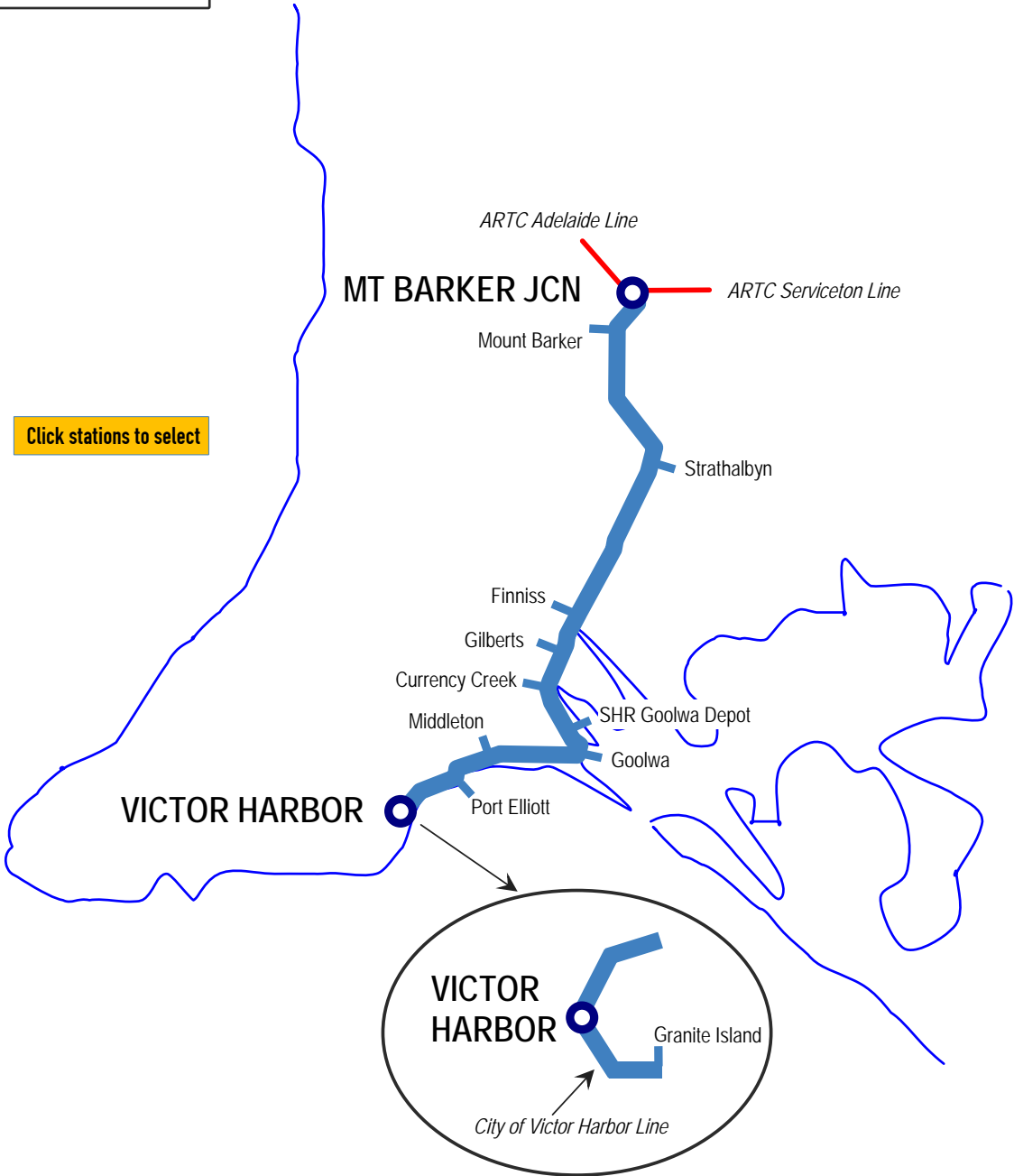

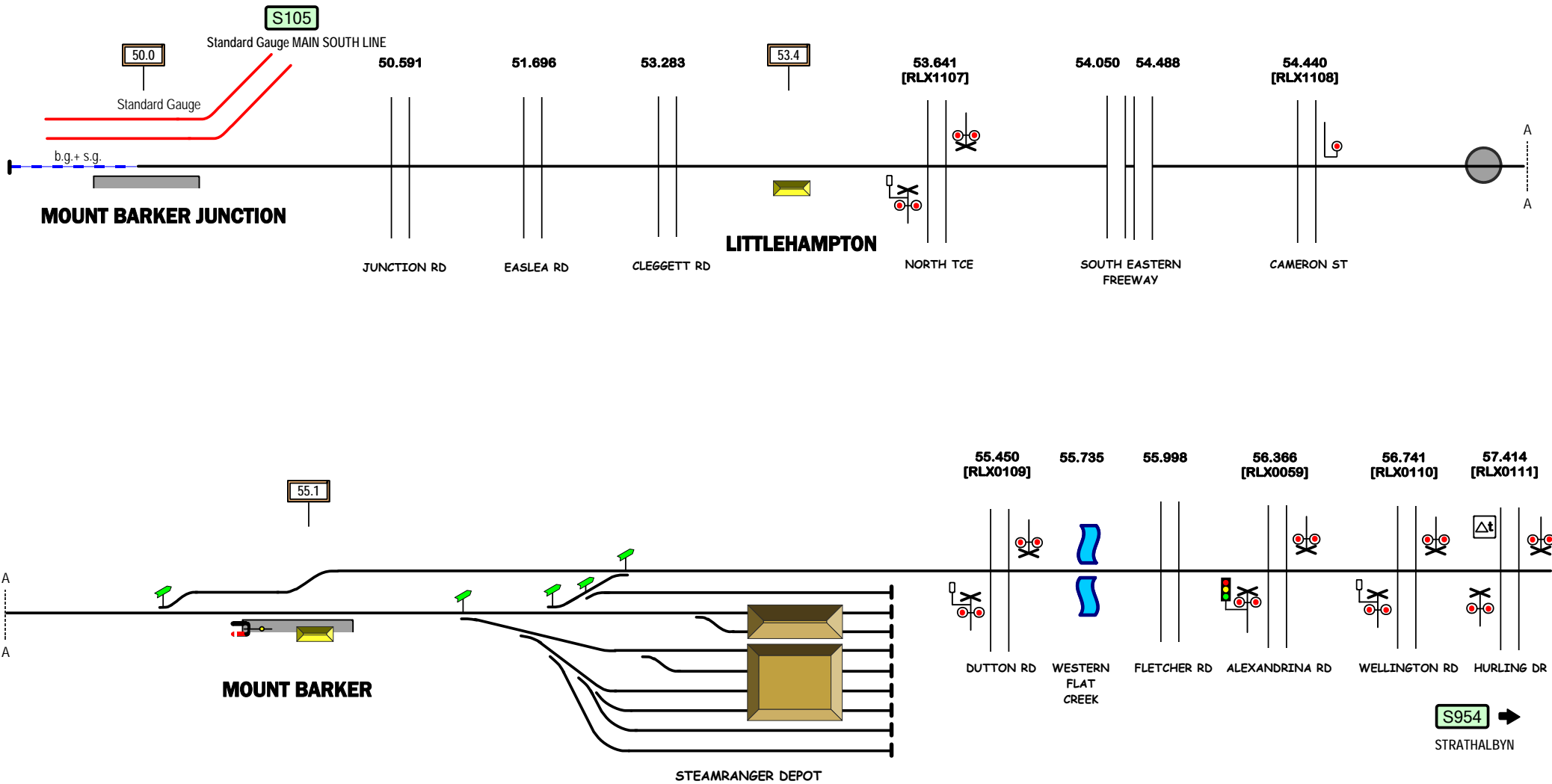

BROAD GAUGE TRACK
MOUNT BARKER JUNCTION - MOUNT BARKER

Steamranger Heritage Railway

Selective button operation
for movement to signal 810 only,
or beyond with progressive operation
of High St & East Tce Xings.

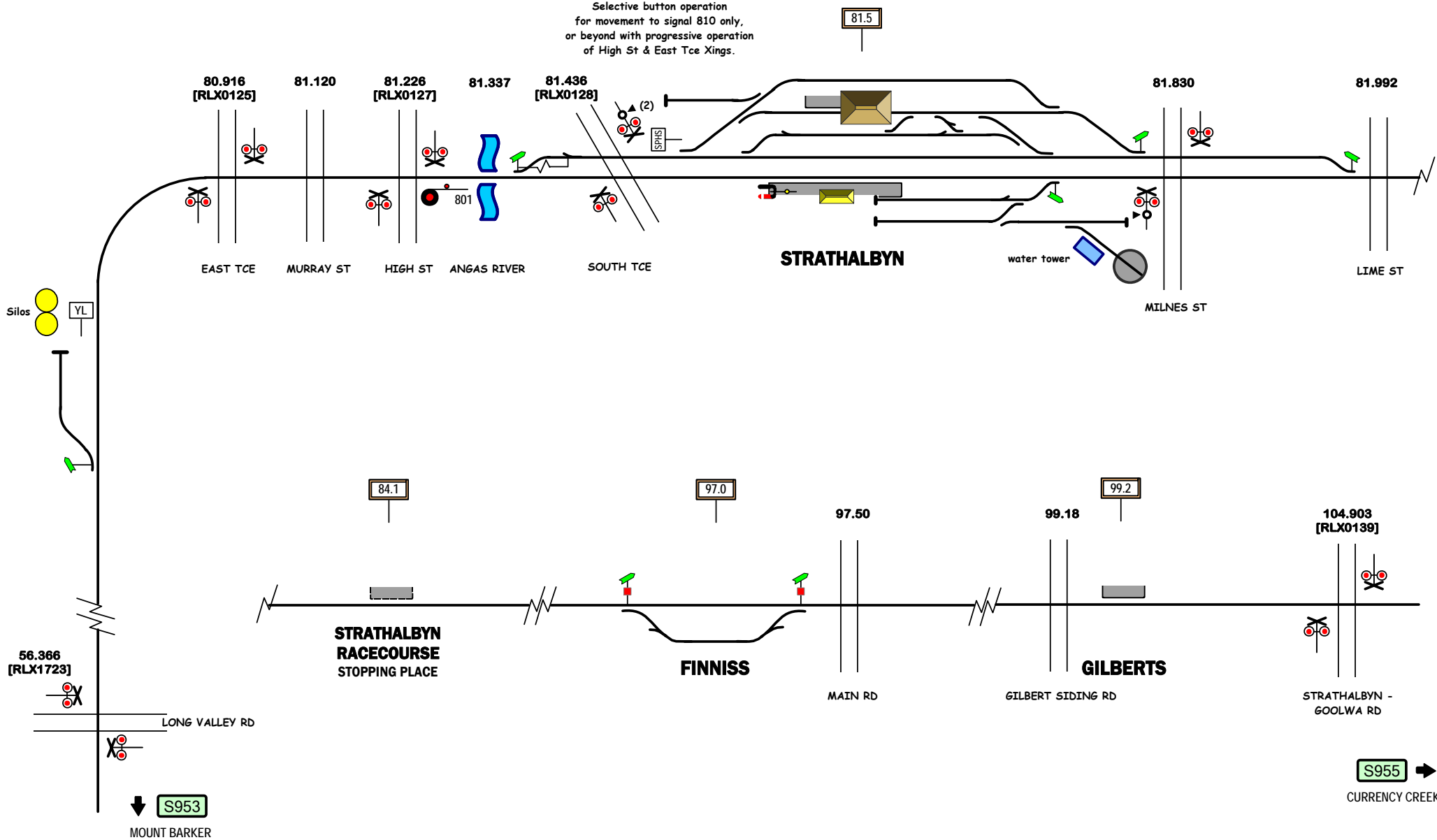

BROAD GAUGE TRACK
STRATHALBYN - GILBERTS

Steamranger Heritage Railway

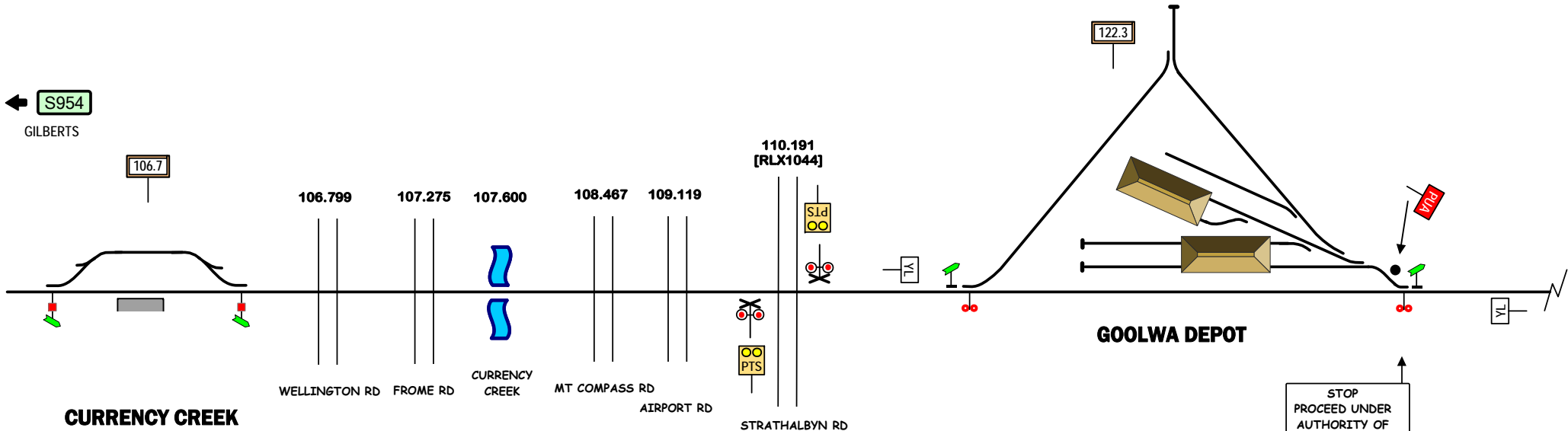

CURRENCY CREEK

GOOLWA DEPOT

STOP
PROCEED UNDER
AUTHORITY OF
TRAIN CONTROL

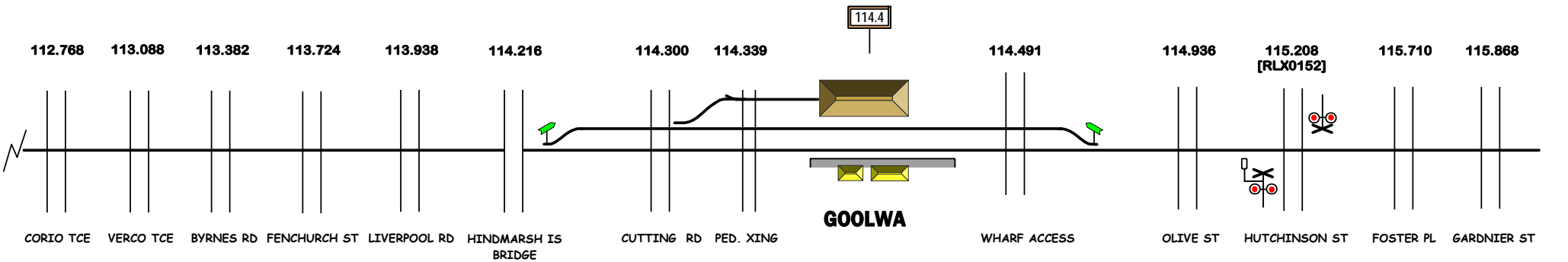

GOOLWA

S956 →
MIDDLETON

BROAD GAUGE TRACK
CURRENCY CREEK - GOOLWA
Steamranger Heritage Railway

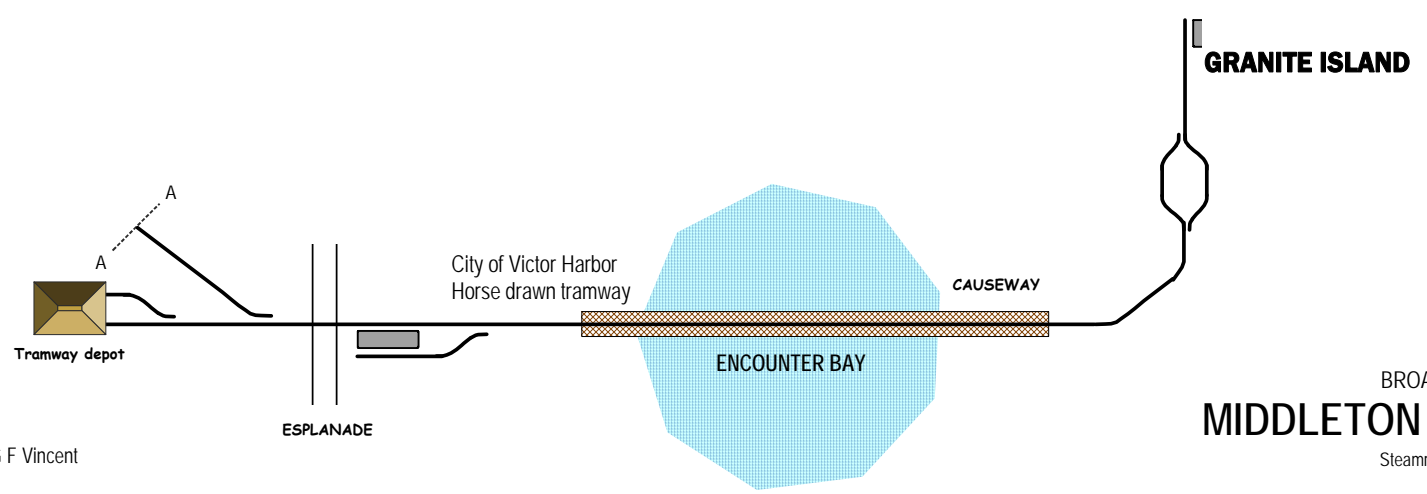
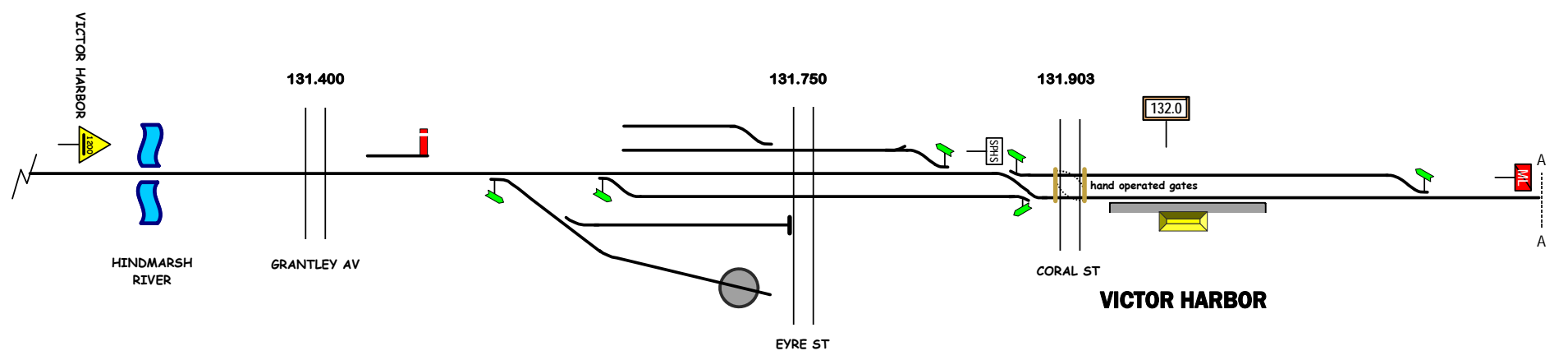
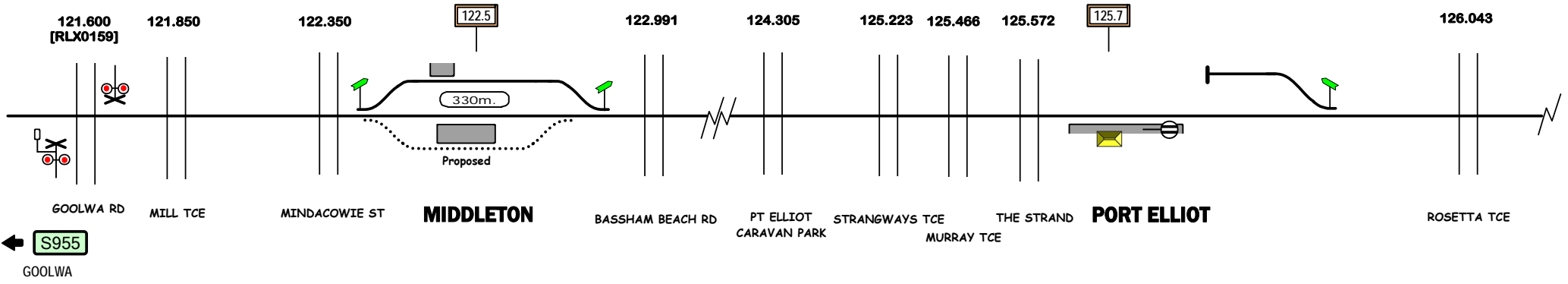

BROAD GAUGE TRACK
MIDDLETON - VICTOR HARBOR

Steamranger Heritage Railway

