

Makita

2021

PRODUCT CATALOGUE



Makita **Power Tools**

Index

Category		CL121D	84	DHK180	new	53	DTD152	48	DUR368L	new	133	GA4050R	new	107	
Cordless Tools 40V XGT	06	CL183D	73	DHP453		46	DTD153	48	DUR369A	new	41	GA5010		107	
Cordless Tools 18V x 2	24	CP100D	80	DHP458		45	DTD154	48	DUR369A	new	133	GA5020C		106	
Cordless Tools 18V	44	DA3010F	94	DHP482		46	DTD155	48	DUT130		63	GA5040R		107	
Cordless Tools 12V CXT	74	DA333D / DA332D	78	DHP483		46	DTD156	new	48	DUX18Z	new	66	GA5050R	new	107
Cordless Tools 10.8V, 7.2V & 3.6V	93	DBM131	94	DHP484		45	DTD171	47	DUX60		37	GA7020		109	
Drilling / Fastening	94	DBM230	94	DHP485		46	DTL063	51	DUX60		132	GA7030		108	
Impact Wrench	94	DBS180	new	53	DHR165	53	DTM51	58	DVC150L		32	GA7050		109	
Impact Drilling / Demolition	95	DCB200 / CB100D	91	DHR171		53	DTR180	55	DVC151L		32	GA7050R		109	
Cutting	102	DCE090	new	28	DHR182	52	DTW1001	49	DVC155L	new	32	GA7060		109	
Grinding / Sanding	104	DCF102	71	DHR202		52	DTW1002	49	DVC261		33	GA7060R		108	
Sawing	113	DCF201	71	DHR241		52	DTW181	50	DVC560	new	30	GA7061		108	
Planing / Routersing	115	DCG180	62	DHR282 / DHR280		27	DTW190	50	DVC660	new	31	GA7061R		108	
Dust Extraction	117	DCJ205 / DCJ206 / DCV202	new	89	DHS475	59	DTW251	50	DVC665	new	31	GA9020		109	
Pneumatic Tools / Others	126	DCL180	64	DHS661 / DHS660		59	DTW285	50	DVC750L		63	GA9030		108	
maktec	127	DCL184	new	64	DHS780	26	DTW300	new	50	DVC862L		32	GA9040S	108	
Outdoor Power Equipment	128	DCL280F	64	DHS783		26	DTW450	49	DVC864L		32	GA9060		109	
MT Series	143	DCL281F	64	DHS900	new	26	DTW700	new	49	DVC865L	new	33	GA9060R	108	
Model		DCL282F	64	DHW080		34	DUB183	69	DVF104		68	GA9061		108	
2712	113	DCO181	new	60	DHW080	142	DUB183	140	DVF104		142	GA9061R		108	
3709	115	DCS551	55	DJR186		59	DUB184	69	DVF154		68	GB602		112	
4131	102	DCS553	54	DJR188		59	DUB184	140	DVF154		142	GB801		112	
4327	114	DCS9010	134	DJR360		28	DUB186	new	69	DVP180		62	GD0601	111	
6412	94	DCU180	67	DJS161		56	DUB186	new	140	DWR180	new	51	GD0603	111	
6906	95	DCW180	new	92	DKP181	new	60	DUB361	43	DWT310		27	GD0801C	111	
9031	112	DDA460	29	DLM382	new	139	DUB361	140	EA3502S40B		134	GS5000		112	
9032	112	DDF083	45	DLM382 / DLM432	new	40	DUB362	43	EA4301F		134	GS6000		112	
9741	112	DDF453	44	DLM432	new	139	DUB362	140	EA6100P45E		134	HB500		95	
1911B	115	DDF458	44	DLM460		40	DUB363	new	42	EA7300P45E		134	HG5030K	126	
2012NB	115	DDF482	44	DLM460		139	DUB363	new	140	EA7900P		134	HG6030K	126	
2107FK	103	DDF483	45	DLM462	new	139	DUC254		66	EB5300TH		139	HG6530V	new	126
4100KB	102	DDF484	44	DLM462 / DLM530 / DLM532	new	40	DUC254	135	EB7660TH		140	HK1820		100	
4100NH3	102	DDF485	44	DLM530	new	139	DUC353	134	EH5000W		135	HM0810T		100	
4112HS	102	DDG460	new	29	DLM532	new	139	DUC355	134	EH6000W		135	HM0870C	100	
4114S	102	DF001D	93	DLM533	new	40	DUC355 / DUC353	36	EH7500SX		135	HM1205C		100	
4350CT	114	DF001G	new	8	DLM533	new	138	DUC356	new	36	EH7500W		135	HM1213C	100
5402NA	114	DF002G	new	8	DLS111		27	DUC356	new	134	EK6101	new	141	HM1306	100
6922NB	95	DF012D	93	DLS211		28	DUH502	68	EK7301	new	141	HM1812		100	
6924N	95	DF0300	96	DLS600		59	DUH502 / DUH602 / DUH752	137	EK7651H		140	HP001G	new	9	
7104L	115	DF331D	77	DLS714		28	DUH602	new	68	EK8100		140	HP0300	96	
9237C	111	DF332D / DF032D	77	DLW140		25	DUH604	new	67	ELM3720		139	HP1630	95	
9553B	106	DF333D / DF033D	77	DML800		71	DUH604	136	ELM4121		139	HP2070		95	
9553NB	106	DF457D	73	DML805		71	DUH651	43	ELM4621		139	HP331D		77	
9556HB	106	DFJ210	87	DML815	new	71	DUH651	138	EM2500U		132	HP332D		78	
9558HN	107	DFJ211	87	DMP180	new	72	DUH752	68	EM3400U		132	HP333D		77	
9565CR	107	DFJ212	87	DP2010		94	DUH754	new	67	EN5950SH		138	HP457D	73	
AF506	126	DFJ213	87	DP4010		94	DUH754	new	136	EN7350SH		138	HP488D	new	73
AT1216AZ	126	DFJ214	87	DPB182		56	DUM604	66	EVH2000		142	HR001G	new	8	
BBA520	142	DFS250	52	DPB183	new	56	DUM604	138	EY2650H25H		135	HR003G	new	8	
BHX2500	139	DFS251	52	DPC6430		140	DUP361	42	FS2700		94	HR140D		80	
BO3710	112	DFV210	87	DPO500		62	DUP361	135	GA003G	new	11	HR166D		80	
BO4556	112	DGA411	58	DPP200	new	54	DUP362	42	GA005G	new	11	HR1840		95	
BO5031	112	DGA413	58	DPT353		62	DUP362	135	GA011G	new	11	HR2020		95	
BO6030	112	DGA417	58	DRT50		61	DUR187L	66	GA013G	new	11	HR2230		95	
CA5000X	103	DGA419	new	58	DRV250 / DRV150	62	DUR187L	132	GA021G	new	11	HR2470		98	
CC301D	80	DGA511	58	DSC102		54	DUR190L	new	65	GA023G	new	11	HR2630	98	
CF101D	85	DGA513	58	DSC191		54	DUR190L	new	132	GA027G	new	11	HR2650	98	
CG100D	83	DGA517	58	DSC251		54	DUR190U	new	65	GA029G	new	11	HR2810	98	
CL106FD	84	DGA519	new	58	DSD180	60	DUR190U	new	132	GA037G / GA038G	new	10	HR4002	98	
CL107FD	84	DGA701 / DGA700	27	DSL800		53	DUR368A	new	133	GA4032		106	HR4003C	98	
CL108FD	84	DGA901	27	DSP600		28	DUR368A / DUR368L	new	41	GA4040		106	HR4013C	98	

























Index

HR5202C	98	M4100B	145	TD022D	93
HR5212C	98	M4101B	145	TD110D	78
HS003G	new 13	M4301B	147	TD111D	78
HS0600	114	M4302B	147	TD127D	73
HS7010	113	M4500KB	147	TL064D	78
HS7600	114	M5801B	147	TL065D	79
HW101	141	M6200B	144	TM3000CX1	112
HW102	141	M6202XB	144	TM30D	82
HW111	141	M6501B	144	TW001G	new 9
HW112	141	M6600B	144	TW004G	new 9
HW120	141	M8600B	144	TW0200	95
HW1200	141	M8700B	144	TW0350	94
HW121	141	M8701B	144	TW060D	80
HW1300	141	M9002B	146	TW1000	95
HW131	142	M9100B	146	TW100D	93
HW132	141	M9200B	146	TW140D	79
HW140	142	M9201B	146	TW141D	79
HW151	142	M9202B	146	TW160D	79
JN1601	103	M9400B	146	TW161D	79
JN3201	103	M9506B	145	UB1102	117
JR001G	new 14	M9508B	146	UC4041A	134
JR103D	82	M9509B	145	UC4550A	new 134
JR3050T	114	M9511B	146	UH201D	new 83
JR3051T	new 114	M9512B	146	UH201D	new 138
JR3061T	new 114	M9513B	146	UH4261	135
JR3070CT	114	M9800B	new 146	UH5261	135
JS1601	103	MLT100	113	UH6570	135
JS1602	103	MP100D	85	UM600D	83
JS3201	103	MT410	127	UR100D	83
JV0600K	114	N5900B	new 114	UR100D	133
JV103D	82	PC5000C	new 111	UR101C	new 132
JV183D	73	PC5001C	111	UR101C / UR201C	new 38
LB1200F	115	PC5010C	111	UR201C	new 132
LC1230	102	PDC01	new 38	UR3501	132
LD030P	127	PDC01	new 133	UX01G	new 16
LD050P	127	PJ7000	115	UX01G	new 132
LD080P	127	PLM4620N2	138	VC2000L	new 117
LH1200FL	113	PLM4625NP	138	VC2510LX1	117
LS002G	new 12	PM7650H	140	VC3210LX1	117
LS1019L	113	PO5000C	111	WR100D	85
LS1030N	113	PO6000C	111		
LS1040	113	PT354D	83		
LS1045	113	PW5001C	111		
LS1219L	113	RBC411U	132		
LS1221	113	RP1800	115		
LW1400	102	RP2301FC	115		
LW1401	102	RT0700C	115		
M0401B	145	SA7000C	111		
M0600B	144	SC103D	new 81		
M0801B	144	SD100D	82		
M0900B	145	SG1251J	102		
M0910B	145	SJ401	115		
M0921B / M0920B	146	SK104Z	127		
M1902B	147	SK105GD / SK105D	76		
M2401B	145	SK106GD / SK106D	76		
M2402B	new 145	SK312GD/SK209GD	76		
M2403B	new 145	SP6000	114		
M3600B	147	ST113D	82		
M3601B	147	TB131	94		
M3700B	147	TD001G	new 9		
M4000B	147	TD0101	94		

Icons

	Double Insulation		Hook & Loop
	Variable Speed		SDS-PLUS Shank
	Constant Speed		SDS-PLUS Shank
	Reversing		SDS-MAX Shank
	Mechanical 2-Speed		17mm Hex Shank
	Mechanical 3-Speed		19mm Hex Shank
	Electronic 4-Speed		21mm Hex Shank
	Electronic 3-Speed		28.6mm Hex Shank
	Electronic 2-Speed		Spline Shank
	Brake		30mm Hex Shank
	Torque Setting 5		Bevel Cutting 45 left
	Torque Setting 9		Bevel Cutting L45 R5
	Torque Setting 10		Anti Vibration
	Torque Setting 16		Automatic Oiling
	Torque Setting 18		Chain Brake
	Torque Setting 20		Primer Pump
	Torque Setting 21		Capacitor Discharge Ignition
	Torque Limiter		Decompression Valve
	Dust Collecting		Auto Decompression
	Bayonet Shank Jig Saw Blade		Rapid Start
	Makita Shank Jig Saw Blade		Wooden Carrying Case
	Orbital Cutting		Carrying Case
	Built-in Job Light		
	Keyless Chuck		
	Soft Start		
	Stainless Tank		
	Revolving Hose		
	Static Free Hose		
	Depth Adjusting		
	Sequential or Bump-fire		
	Sequential		
	Wire Collated Nail		
	Sheet Collated Nail		

MAKITA CORDLESS PART NUMBER BREAKDOWN

DSE	Charger (DC10WA), 2x10.8V 1.35h Battery (BL1013)	
DWE	Charger (DC18WA), 2 x 18V 1.5Ah Batteries (BL1815G)	
DWX	Charger (DC10WA), 1x10.8V 1.3Ah Battery (BL1013)	
PT2	Rapid Charger Dual Port (DC18RD), 2 x 18V 5.0Ah Batteries (BL1850B), Makpac	
RFE	Rapid Charger (DC18RC), 2 x 18V 3.0Ah Batteries (BL1830B)	
RFJ	Rapid Charger (DC18RC), 2 x 18V 3.0Ah Batteries (BL1830B), Makpac	
RFX1 RFX4	Rapid Charger (DC18RC), 2 x 18V 3.0Ah Batteries (BL1830B), 74 nos Bit Set	
RM	Rapid Charger (DC18RC), 1 x 18V 4.0Ah Battery (BL1840B)	
RME	Rapid Charger (DC18RC), 2 x 18V 4.0Ah Batteries (BL1840B)	
RT	Rapid Charger (DC18RC), 1 x 18V 5.0Ah Batteries (BL1850B)	
RTE	Rapid Charger (DC18RC), 2 x 18V 5.0Ah Batteries (BL1850B)	
RTJ RTJX7	Rapid Charger (DC18RC), 2 x 18V 5.0Ah Batteries (BL1850B), Makpac	
SAE	Charger (DC10SB), 2 x 12V Max 2.0Ah Batteries (BL1021B)	
SF	Charger (DC18SD), 1 x 18V 3.0Ah Battery (BL1830B)	
SFE	Charger (DC18SD), 2 x 18V 3.0Ah Batteries (BL1830B)	
SFE3	Charger (DC18SD), 3 x 18V 3.0Ah Batteries (BL1830B)	
SFX1	Charger (DC18SD), 2 x 18V 3.0Ah Batteries (BL1830B), Tool Bag	
SYE	Charger (DC18SD), 2 x 18V 1.5Ah Batteries (BL1815N)	
WAE	Charger (DC10WD), 2 x 12V 2.0Ah Batteries (BL1021B)	
WAX1	Charger (DC10WD), 2 x 12V 2.0Ah Battery (BL1021B), 74nos bit set	
WYE	Charger (DC10WD), 2 x 12V Max 1.5Ah Batteries (BL1016)	
WYJ	Charger (DC10WD), 2 x 12V Max 1.5Ah Batteries (BL1016), Makpac	
Z	Tool Only (Batteries, Charger not included)	
ZJ	Tool Only, Connector Case	

PRODUCTS

▣ CORDLESS TOOLS

INTRODUCING

XGT
40V *Li-ion*
max



High Power

Durability

Digital Communication



40V Li-ion max

LED Worklight
ML002G / ML003G



Job Site Radio
MR001G / MR002G /
MR003G / MR004G

Flashlight
ML001G



High Power

Durability

Digital
Communication

Brad Nailer
FN001G



Fan
CF001G / CF002G



Hedge Trimmer
UH004G / UH005G / UH006G /
UH007G / UH008G / UH009G



Blower
UB001G



Earth Auger
DG001G



Grass Trimmer
UR002G / UR003G / UR006G /
UR007G / UR008G

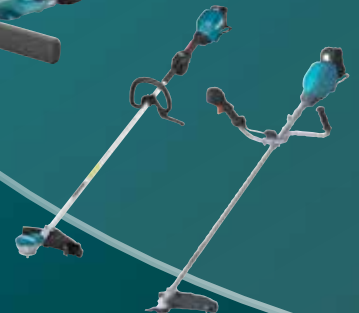

Rotary Hammer
HR006G



Demolition Hammer
HM002G



Battery

BL4020 (2.0Ah) BL4025 (2.5Ah)



Impact Driver
TD001G



Driver Drill
DF001G / DF002G



Hammer Driver Drill
HP001G / HP002G



40Vmax series movies

This movie was filmed in Japan.
Models and specs may vary by country.

Impact Wrench
TW001G / TW004G / TW005G /
TW007G / TW008G



Rotary Hammer
HR005G



Angle Drill
DA001G / DA002G



Demolition Hammer
HM001G



Combination Hammer
HR001G / HR002G /
HR003G / HR004G



Angle Grinder

GA003G / GA004G / GA005G / GA006G / GA007G / GA008G / GA011G /
GA012G / GA013G / GA014G / GA015G / GA016G / GA021G / GA022G /
GA023G / GA024G / GA025G / GA026G / GA027G / GA028G / GA029G /
GA030G / GA031G / GA032G / GA035G / GA036G / GA037G / GA038G

Circular Saw
HS003G / HS004G



Recipro Saw
JR001G



**Multi Function
Power Head**
UX01G



Cleaner
CL001G



Rear Handle Saw
RS001G / RS002G



Slide Compound Miter Saw
LS002G / LS003G



Charger

BL4040 (4.0Ah)



BL4050F (5.0Ah)



DC40RA



DC40RB



DC40RC



**ADP10
Adapter for LXT Battery**





HR001G 40Vmax XGT BL AFT AWS AVT SOFT NO LOAD Cordless 28 mm (1-1/8") Combination Hammer, SDS-PLUS Bits

Cordless Combination Hammer



new

- Excellent tool balance for easy handling and control
- Anti-Vibration Technology (AVT) for extremely low vibration
- High power similar
- Auto-start Wireless System (AWS) connects to vacuum cleaner with Bluetooth
- Active Feedback sensing Technology (AFT) turns the motor off if bit rotation is suddenly forced to stop



XGT **BL** **AFT** **AWS** **AVT** **SOFT** **NOLOAD** **XPT**



Side Grip, Depth Gauge, Battery, Charger, Wireless Unit (country-specific), Dust Cup (country-specific), Cleaning cloth (country-specific), Bit Grease (country-specific)

Impact Energy	EPTA-Procedure 05/2009: 2.8 J
Capacity	Concrete / Steel / Wood / Core Bit / Diamond Core Bit (Dry Type): 28 / 13 / 32 / 54 / 65 mm (1-1/8" / 1/2" / 1-1/4" / 2-1/8" / 2-9/16")
Blows Per Minute (BPM)	0 - 5,000
No Load Speed (RPM)	0 - 980
Chuck Capacity	1.5 - 13 mm (1/16 - 1/2")
Vibration Level	Hammer Drilling into Concrete: HR001G: 7.0 m/s ²
Dimensions (L x W x H)	HR001G: w/ BL4040: 373 x 102 x 238 mm (14-3/4 x 4 x 9-3/8")
Net weight	HR001G: 3.9 - 4.6kg (8.6 - 10.1 lbs.)

HR003G 40Vmax XGT BL AVT Cordless 28 mm (1-1/8") Combination Hammer, SDS-PLUS Bits

Cordless Combination Hammer



new

- Excellent tool balance for easy handling and control
- Anti-Vibration Technology (AVT) for extremely low vibration
- High power similar
- 3-mode operation for "Rotation Only", "Hammering with Rotation" or "Hammering Only"
- One touch sliding chuck enables quick and easy bit changes

XGT **BL** **AVT** **XPT**



Side Grip, Depth Gauge, Battery, Charger, Wireless Unit (country-specific), Dust Cup (country-specific), Cleaning cloth (country-specific), Bit Grease (country-specific)

Impact Energy	EPTA-Procedure 05/2009: 2.8 J
Capacity	Concrete / Steel / Wood / Core Bit / Diamond Core Bit (Dry Type): 28 / 13 / 32 / 54 / 65 mm (1-1/8" / 1/2" / 1-1/4" / 2-1/8" / 2-9/16")
Blows Per Minute (BPM)	0 - 5,000
No Load Speed (RPM)	0 - 980
Chuck Capacity	1.5 - 13 mm (1/16 - 1/2")
Vibration Level	Hammer Drilling into Concrete: HR001G: w/ BL4040: 6.5 m/s ²
Dimensions (L x W x H)	w/ BL4040: 373 x 102 x 238 mm (14-3/4 x 4 x 9-3/8")
Net weight	3.9 - 4.6 kg (8.6 - 10.1 lbs.)

HR003GM101

HR003GZ

DF001G 40Vmax XGT BL AFT Cordless 13 mm (1/2") 125 N-m (1,100 in.lbs.) Driver Drill

Cordless Driver Drill



new

- Excellent performance in continuous heavy duty applications
- Outstanding drilling speed; Delivers 20% or more higher speed than previous model
- Increased max speed (0-2,600 RPM) in High mode for faster drilling speed in light duty applications
- Variable 2-speed transmission (0-650 & 0-2,600 RPM) for a wide range of drilling and fastening applications
- Compact overall length for easy handling and control



XGT **BL** **AFT** **XPT**



Side Grip, Belt Clip, (+)(-) Bit, Bit Holder, Battery, Charger

Capacity	Steel: 20 mm (13/16") Wood (Auger-Bit): 50 mm (2") Wood (Self-Feed Bit): 76 mm (3") Wood (Hole Saw): 152 mm (6") Sliding Board: 220 mm (8-5/8")
Chuck Capacity	1.5 - 13 mm (1/16 - 1/2")
No Load Speed (RPM)	High / Low: 0 - 2,600 / 0 - 650
Max Fastening Torque	Hard / Soft: 140 / 68 N-m (1,240 / 600 in.lbs.)
Max Lock Torque	125 N-m (1,100 in.lbs.)
Vibration Level	Drilling into Metal: 2.5 m/s ² or less
Sound Pressure Level	75 dB(A)
Dimensions (L x W x H)	w/ BL4025: 181 x 86 x 275 mm (7-1/8 x 3-3/8 x 10-7/8") w/ BL4040: 181 x 86 x 282 mm (7-1/8 x 3-3/8 x 11-1/8")
Net weight	2.7 - 3.0 kg (5.9 - 6.6 lbs.)

DF001GD201

DF001GZ

DF002G 40Vmax XGT BL Brushless Cordless 13 mm (1/2") 65 N-m (580 in.lbs.) Driver Drill

Cordless Driver Drill



new

- Delivers higher drilling, driving and fastening speed than DDF484
- Compact and ergonomic design at only 170 mm (6-11/16") long
- Aluminum gear housing creates an impression of rigidity and luxuriousness
- Variable 2-speed (0-600 & 0-2,200 RPM) for a wide range of drilling and fastening applications
- Built-in twin LED lights with pre-glow and afterglow functions illuminate the work area



XGT **BL** **XPT**



(+)(-) Bit, Belt Clip, Battery, Charger

Capacity	Steel / Wood: 13 / 38 mm (1/2" / 1-1/2")
Chuck Capacity	1.5 - 13 mm (1/16 - 1/2")
No Load Speed (RPM)	High / Low: 0 - 2,200 / 0 - 600
Max Fastening Torque	Hard / Soft: 64 / 30 N-m (570 / 270 in.lbs.)
Max Lock Torque	65 N-m (580 in.lbs.)
Vibration Level	Drilling into Metal: 2.5 m/s ² or less
Sound Pressure Level	78 dB(A)
Dimensions (L x W x H)	w/ BL4025: 170 x 86 x 265 mm (6-11/16 x 3-3/8 x 10-3/8") w/ BL4040: 170 x 86 x 290 mm (6-11/16 x 3-3/8 x 11-3/8")
Net weight	1.9 - 2.8 kg (4.2 - 6.2 lbs.)



HP001G 40Vmax XGT BL AFT Cordless 13 mm (1/2") 125 N-m (1,100 in.lbs.) Hammer Driver Drill

Cordless Hammer Driver Drill



new

- Excellent performance in continuous heavy duty applications
- Outstanding drilling speed; Delivers 20% or more higher speed than previous model
- Increased max speed (0-2,600 RPM) in High mode for faster drilling speed in light duty applications
- Variable 2-speed transmission (0-650 & 0-2,600 RPM) for a wide range of drilling, fastening and hammer drilling applications
- Compact overall length for easy handling and control



XGT MOTOR AFT XPT



Depth Gauge, Side Grip, Belt Clip, (+)(-) Bit, Bit Holder, Battery, Charger

Capacity	Steel: 20 mm (13/16") Wood (Auger-Bit): 50 mm (2") Wood (Self-Feed Bit): 76 mm (3") Wood (Hole Saw): 152 mm (6") Siding Board: 220 mm (8-5/8") Masonry: 20 mm (13/16")
Chuck Capacity	1.5 - 13 mm (1/16 - 1/2")
Impacts Per Minute (IPM)	High / Low: 0 - 39,000 / 0 - 9,750
No Load Speed (RPM)	High / Low: 0 - 2,600 / 0 - 650
Max Fastening Torque	Hard / Soft: 140 / 68 N-m (1,240 / 600 in.lbs.)
Max Lock Torque	125 N-m (1,100 in.lbs.)
Vibration Level	Impact Drilling into Concrete: 6.0 m/s ² Drilling into Metal: 2.5 m/s ² or less
Sound Pressure Level	85 dB(A)
Net weight	2.7 - 3.0 kg (6.0 - 6.6 lbs.)

HP001GD201

HP001GZ

TD001G 40Vmax XGT BL Brushless Cordless Wood/Bolt/T-Mode 220 N-m Impact Driver

Cordless Impact Driver



new

- High Power 220 N-m
- Genuine solution for high demand industrial users
- Having excellent ability to perform heavy-duty continuous tightening; Able to continuously tighten heavy duty screws such as metal fastening screws and lag screws
- Delivers up to 50% higher work speed than DTD171
- Multiple operation modes for a wide range of applications; 4-speed power selection plus 6 Assist modes (2 T-modes, 1 Wood mode, 3 Bolt modes)



XGT MOTOR BL XPT



Phillips Bit, Belt Clip, Hand Strap, Battery, Charger

TD001GM201

Capacity	Machine Screw: M4 - M8 (5/32 - 5/16") Standard Bolt: M5 - M16 (3/16 - 5/8") High Strength Bolt: M5 - M14 (3/16 - 9/16") Coarse thread (in length): 22 - 125 mm (7/8 - 4-7/8")
Hex Shank	6.35 mm (1/4")
No Load Speed (RPM)	Max / Hard / Mid / Soft / Wood / Bolt (1) / (2) / (3) / T (1) / (2) mode: 0 - 3,700 / 3,200 / 2,100 / 1,100 / 1,800 / 2,500 / 3,700 / 3,700 / 2,400 / 3,700
Impacts Per Minute (IPM)	Max / Hard / Mid / Soft / Wood / Bolt (1) / (2) / (3) / T (1) / (2) mode: 0 - 4,400 / 3,600 / 2,600 / 1,100 / 4,400 / - / 4,400 / 4,400 / - / 2,600
Max Fastening Torque	220 N-m (1,950 in.lbs.)
Fastening Torque	Hard / Mid / Soft: 170 / 50 / 20 N-m
Dimensions (L x W x H)	w/ BL4025: 120 x 86 x 245 mm (4-3/4 x 3-3/8 x 9-5/8")
Net weight	1.7 - 2.0 kg (3.7 - 4.4 lbs.)

TD001GD201

TD001GZ

TW001G 40Vmax XGT BL Cordless 3/4" (19 mm) 1,800 N-m Impact Wrench, Reverse Rotation Auto Stop Mode

Cordless Impact Wrench



new

- Higher torque and more compact than DTW1001
- High torque but compact overall length for easy handling and control
- Electronic 4 stage impact power selection for added versatility
- 3 modes of reaction time for automatic stop available both in forward and reverse rotation modes
- Trigger switch with full speed mode allows for less hand and finger fatigue



XGT MOTOR BL XPT



Belt Clip, Battery, Charger

Fastening Capacities	Standard Bolt: M12 - M36 (1/2 - 1-7/16") High Strength Bolt: M10 - M27 (3/8 - 1-1/16")
Square Drive	19 mm (3/4")
No Load Speed (RPM)	Max / Hard / Mid / Soft: 0 - 1,800 / 1,400 / 1,150 / 950
Impacts Per Minute (IPM)	Max / Hard / Mid / Soft: 0 - 2,500 / 2,400 / 2,200 / 1,900
Max Fastening Torque	1,800 N-m (1,330 ft.lbs.)
Vibration Level	Impact tightening of fasteners of the maximum capacity of the tool: 18.5 m/s ²
Sound Pressure Level	100 dB(A)
Sound Power Level	111 dB(A)
Dimensions (L x W x H)	w/ BL4025: 217 x 94 x 297 mm (8-1/2 x 3-11/16 x 11-3/4") w/ BL4040: 217 x 94 x 303 mm (8-1/2 x 3-11/16 x 11-7/8")
Net weight	3.9 - 4.2 kg (8.6 - 9.3 lbs.)

TW001GD201

TW001GZ

TW004G 40Vmax XGT BL Cordless 1/2" (12.7 mm) 350 N-m Impact Wrench, Forward/Reverse Rotation Auto Stop Mode

Cordless Impact Wrench



new

- Increased motor speed under load delivers higher torque than DTW300 and DTW301
- Electronic 4 stage impact power selection for added versatility
- 3 modes of reaction time for automatic stop available both in forward and reverse rotation modes
- Trigger switch with full speed mode allows for less hand and finger fatigue
- Compact design with a short overall length of 144 mm



XGT MOTOR BL XPT



Belt Clip, Battery, Charger

Fastening Capacities	Standard Bolt: M10 - M20 (3/8 - 3/4") High Strength Bolt: M10 - M16 (3/8 - 5/8")
Square Drive	12.7 mm (1/2")
No Load Speed (RPM)	Max / Hard / Mid / Soft: 0 - 3,200 / 2,600 / 1,800 / 1,000
Impacts Per Minute (IPM)	Max / Hard / Mid / Soft: 0 - 4,000 / 3,400 / 2,600 / 1,800
Max Fastening Torque	350 N-m (260 ft.lbs.)
Dimensions (L x W x H)	w/ BL4025: 144 x 86 x 248 mm (5-5/8 x 3-3/8 x 9-3/4") w/ BL4040: 144 x 86 x 253 mm (5-5/8 x 3-3/8 x 10")
Net weight	1.9 - 2.2 kg (4.2 - 4.9 lbs.)

TW004GD201

TW004GZ



GA037G / GA038G 40Vmax XGT BL Cordless 180 mm (7") (GA037G) / 230 mm (9") (GA038G) Angle Grinder, Anti-Restart Function, Electric Brake, Large Trigger Switch
Cordless Angle Grinder



new

- Lightweight for increased operability
- Higher power under heavy load
- Auto-Start Wireless System (AWS) Connects to Compatible Vacuum Cleaners with Bluetooth
- AFT (Active Feedback sensing Technology) turns the motor off if rotation speed suddenly slows or wheel is forced to stop
- Electric brake stops the grinding wheel in 4.5 seconds or less for maximum productivity and increased operator safety



Toolless Wheel Cover / Wheel Cover, Side Grip, Lock Nut Wrench

Wheel Diameter	GA037G: 180 mm (7") / GA038G: 230 mm (9")
Hole Diameter	22.23 mm (7/8")
No Load Speed (RPM)	GA037G: 7,800 / GA038G: 6,600
Circumference of Grip Portion	154 mm
Vibration Level	Surface Grinding w/ Anti-Vibration Side Grip: 7.5 m/s ²
	Disc Sanding w/ Anti-Vibration Side Grip: 2.5 m/s ² or less
Sound Pressure Level	88 dB(A)
Sound Power Level	99 dB(A)
Dimensions (L x W x H)	GA037G: 499 x 200 x 180 mm (19-5/8 x 7-7/8 x 7-1/8")
	GA038G: 499 x 250 x 180 mm (19-5/8 x 9-7/8 x 7-1/8")
Net weight	GA037G: 4.4 - 5.2 kg (9.7 - 11.0 lbs.)
	GA038G: 4.6 - 5.2 kg (10.1 - 11.5 lbs.)



Better gravity balance

High maneuverability in any angle since it is possible to grab the center of gravity

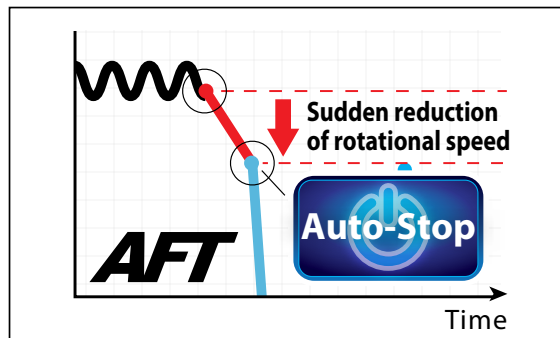

Active Feedback sensing Technology

Torque limiter turns the motor off if the tool is suddenly forced to lock

AWS Auto-start Wireless System

The wireless activation function enables clean and comfortable operation. By connecting a supported tool to the cleaner, you can run the cleaner automatically along with the switch operation of the tool.



Wireless unit is compatible with all supported tools



Electric brake

Electric brake is activated after the tool is switched off.



Slide Switch Type



XGT BL AFT XPT (BRAND)		GA003G new	GA005G new
Wheel Diameter		100 mm (4")	125 mm (5")
Hole Diameter		16 mm (5/8")	22.23 mm (7/8")
No Load Speed (RPM)		8,500	8,500
Vibration Level Surface Grinding w/ Normal Side Grip:		5.0 m/s ²	6.5 m/s ²
Sound Pressure Level / Sound Power Level		81 dB(A) / 92 dB(A)	81 dB(A) / 92 dB(A)
Dimensions (L x W x H) with / BL4025:		398 x 117 x 150 mm (15-5/8 x 4-5/8 x 5-7/8")	398 x 140 x 156 mm (15-5/8 x 5-1/2 x 6-1/8")
	with / BL4040:	410 x 117 x 162 mm (16-1/8 x 4-5/8 x 6-3/8")	410 x 140 x 168 mm (16-1/8 x 5-1/2 x 6-5/8")
Net weight		2.8 - 3.3 kg (6.2 - 7.3 lbs.)	2.9 - 3.6 kg (6.4 - 7.9 lbs.)
		GA003GM201	GA005GM201
		GA003GZ	GA005GZ
XGT BL AWS AFT XPT (BRAND)		GA021G new	GA023G new
Wheel Diameter		100 mm (4")	125 mm (5")
Hole Diameter		16 mm (5/8")	22.23 mm (7/8")
No Load Speed (RPM)		3,000 - 8,500	3,000 - 8,500
Vibration Level Surface Grinding w/ Normal Side Grip:		5.0 m/s ²	6.5 m/s ²
Sound Pressure Level / Sound Power Level		81 dB(A) / 92 dB(A)	81 dB(A) / 92 dB(A)
Dimensions (L x W x H) with / BL4025:		413 x 117 x 150 mm (16-1/4" x 4-5/8" x 5-7/8")	413 x 140 x 156 mm (16-1/4" x 5-1/2" x 6-1/8")
	with / BL4040:	425 x 117 x 162 mm (16-3/4" x 4-5/8" x 6-3/8")	425 x 140 x 168 mm (16-3/4" x 5-1/2" x 6-5/8")
Net weight		2.8 - 3.4 kg (6.2 - 7.5 lbs.)	3.0 - 4.4 kg (6.6 - 9.7 lbs.)
Soft Start	Dust Collection	Carrying Case	
		GA021GM201	GA023GM201
		GA021GD201	GA023GD201
		GA021GZ	GA023GZ

Standard equipment : GA003G, GA005G : Grinding Wheel, Toolless Wheel Cover / Wheel Cover, Side Grip, Lock Nut Wrench, Battery, Charger
 Standard equipment : GA021G, GA022G : Grinding Wheel, Toolless Wheel Cover, Side Grip, Lock Nut Wrench, Battery, Charger

Paddle Switch Type



XGT BL AFT XPT (BRAND)		GA011G new	GA013G new
Wheel Diameter		100 mm (4")	125 mm (5")
Hole Diameter		16 mm (5/8")	22.23 mm (7/8")
No Load Speed (RPM)		8,500	8,500
Vibration Level Surface Grinding w/ Normal Side Grip:		4.5 m/s ²	6.0 m/s ²
Sound Pressure Level / Sound Power Level		81 dB(A) / 92 dB(A)	82 dB(A) / 93 dB(A)
Dimensions (L x W x H) with / BL4025:		398 x 117 x 150 mm (15-5/8 x 4-5/8 x 5-7/8")	398 x 140 x 156 mm (15-5/8 x 5-1/2 x 6-1/8")
	with / BL4040:	410 x 117 x 162 mm (16-1/8 x 4-5/8 x 6-3/8")	410 x 140 x 168 mm (16-1/8 x 5-1/2 x 6-5/8")
Net weight		2.8 - 3.4 kg (6.2 - 7.5 lbs.)	3.0 - 3.6 kg (6.6 - 7.9 lbs.)
		GA011GM201	GA013GM201
		GA011GZ	GA013GZ
XGT BL AWS AFT XPT (BRAND)		GA027G new	GA029G new
Wheel Diameter		100 mm (4")	125 mm (5")
Hole Diameter		16 mm (5/8")	22.23 mm (7/8")
No Load Speed (RPM)		3,000 - 8,500	3,000 - 8,500
Vibration Level Surface Grinding w/ Normal Side Grip:		4.5 m/s ²	6.0 m/s ²
Sound Pressure Level / Sound Power Level		81 dB(A) / 92 dB(A)	82 dB(A) / 93 dB(A)
Dimensions (L x W x H) with / BL4025:		413 x 117 x 150 mm (16-1/4" x 4-5/8" x 5-7/8")	413 x 140 x 156 mm (16-1/4" x 5-1/2" x 6-1/8")
	with / BL4040:	425 x 117 x 162 mm (16-3/4" x 4-5/8" x 6-3/8")	425 x 140 x 168 mm (16-3/4" x 5-1/2" x 6-5/8")
Net weight		2.9 - 3.4 kg (6.4 - 7.5 lbs.)	3.0 - 4.5 kg (6.6 - 9.9 lbs.)
		GA027GM201	GA029GM201
		GA027GD201	GA029GD201
		GA027GZ	GA029GZ
Soft Start	Dust Collection	Carrying Case	

Standard equipment : Grinding Wheel, Toolless Wheel Cover, Side Grip, Lock Nut Wrench, Battery, Charger

- Items of standard equipment and specifications may vary by country or area. - Net weight and dimensions may differ by the type of battery. - Battery runtime may vary as per the application.



LS002G 40Vmax XGT BL AWS Cordless 216 mm (8-1/2") Slide Compound Miter Saw, LED Light

Cordless Slide Compound Miter Saw

new

- More efficient dust extraction
- Switch to start up vacuum cleaner (via AWS) convenient for cleaning after working with this tool
- Rail-forward design enables to be placed against a wall for maximizing work space
- LED lamp to cast an exact cutting line
- Extendable sub tables help stabilize long material cuts

Blade Diameter	216 mm (8-1/2")
Miter Angle	60° L / 60° R
Bevel Angle	48° L / 48° R
Max Cutting Capacity	90° Miter: 70 x 312 mm (2-3/4 x 12-1/4")
No Load Speed (RPM)	4,800
Dimensions (L x W x H)	702 x 551 x 557 mm (27-5/8 x 21-3/4 x 22")
Net weight	16.4 - 17.0 kg (36.2 - 37.6 lbs.)



XGT **BL** **AWS** **DXT**



TCT Saw Blade, Dust Bag, Triangular Rule, Vertical Vise, Hex Wrench, Battery, Charger

LS002GZ



LED lamp to cast an exact cutting line

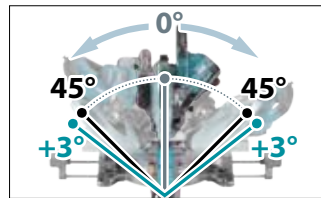

Bevel range of 48° right and left



Rail-forward design
enables to be placed against a wall for maximizing work space.

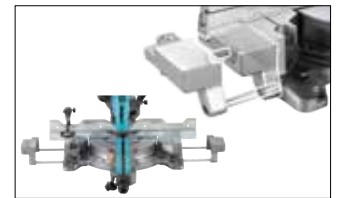

Extendable sub tables
help stabilize long material cuts.

Optimum power supply system and Optimum charging system

The XGT range of tools and batteries come with a built-in program, providing digital communication between the battery and tool. Allowing not only for the battery to talk with tool but also the tool to talk to the battery. Battery technology and motor engineering that work together for optimum performance.



Tool ↔ Battery ↔ Battery Charger
Digital communication

Optimum charging system

Auto maintenance system with two cooling fans for providing more optimum fast charging

Built Tough

High durability specifications specially designed for 40Vmax Li-Ion batteries

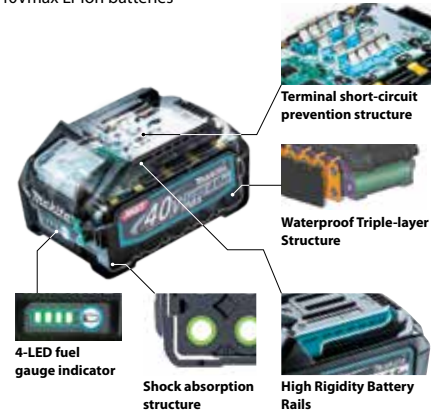

Max. cutting capacity (height x width)

Cross Cut	Miter Cut (left & right)	Bevel Cut (left & right)	Compound Cut
70 x 312mm (2-3/4" x 12-1/4")	Miter 45° left / right	Bevel 45° left 50 x 312mm (2" x 12-1/4") Bevel 45° right 30 x 312mm (1-3/16" x 12-1/4")	Miter 45° left 50 x 220mm (2" x 8-5/8") Bevel 45° right 30 x 220mm (1-3/16" x 8-5/8")

Accessories

Horizontal vise
Part No. 122567-9





HS003G 40Vmax XGT BL AWS ADT Cordless 190/185 mm (7-1/2" / 7-1/4") Magnesium Circular Saw, Electric Brake, Soft Start, Twin LED Light

Cordless Circular Saw

- Lightweight & high power
- 40Vmax XGT Li-Ion battery and BL motor allow for excellent balance of high power and lightweight maneuverability similar to corded tools
- BL motor delivers 6,000 RPM for fast cutting
- BL motor eliminates carbon brushes, enabling the BL motor to run cooler and more efficiently for longer life
- Large cutting capacity (68.5 mm at 90°) and bevel capacity (0° - 56°) with a positive stop at 22.5° and 45°

Blade Diameter	190 / 185 mm (7-1/2" / 7-1/4")
Max Cutting Capacity	HS003G: 90°: 68.5 / 66 mm (2-11/16" / 2-5/8") 45°: 47.5 / 45.5 mm (1-7/8" / 1-13/16") 56°: 35.5 / 34 mm (1-3/8" / 1-5/16") 45°: 44.5 / 43 mm (1-3/4" / 1-11/16") 48°: 42 / 41 mm (1-5/8" / 1-5/8")
No Load Speed (RPM)	6,000
Vibration Level	Cutting Wood / Cutting Metal: 2.5 m/s ² or less
Sound Pressure Level	93 dB(A)
Sound Power Level	104 dB(A)
Dimensions (L x W x H)	w/ BL4025: 316 x 200 x 290 mm (12-1/2 x 7-7/8 x 11-3/8")
Net weight	4.1 - 4.4 kg (9.0 - 9.7 lbs.)



TCT Saw Blade, Dust Nozzle, Hex Wrench,

HS003GM201

HS003GZ

ADT Automatic torque Drive Technology

automatically changes the cutting speed according to load conditions for an optimum operation:

- On light duty: high-speed rotation mode
- On heavy duty: high torque mode

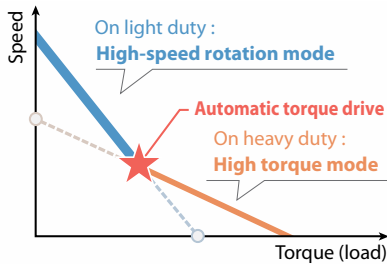

AWS Auto-start Wireless System

connects to compatible vacuum cleaner with Bluetooth. The vacuum cleaner automatically runs while the switch is on.



Switch on the tool



Vacuum cleaner is activated

Compatible with guide rail without adapter (HS004G only)



Blower function



Twin LED Job light



Max. bevel capacity



Overload alert using driving mode lamp



**Recipro Saw
JR001G**



High Durable Structure



Easy blade ejection lever



Smooth cutting with vertical crank system

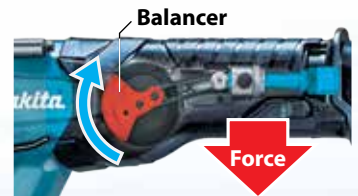

Tool-less shoe adjustment



JR001G

Cordless Recipro Saw

40Vmax XGT BL Brushless Cordless Recipro Saw



- Compact & High Power
- High power delivered by the BL motor designed to best suit XGT battery
- Increased maneuverability thanks to the lightweight achieved by employing one XGT battery drive instead of two LXT batteries
- High durability; More effective lubricating mechanism for the slider section; Gear shaft section enforced by inserting a metal piece
- Rubber joint construction for minimizing the battery terminal from chattering or the battery rails from being worn out



Recipro Saw Blades, Charger, Battery

Length of Stroke	32 mm (1-1/4")
Strokes Per Minute (SPM)	High / Low: 0 - 3,000 / 0 - 2,300
Capacity	Pipe : 130 mm (5-1/8") Wood: 255 mm (10")
Vibration Level	Cutting Boards: 18.0 m/s ² Cutting Wooden Beams: 19.5 m/s ²
Sound Pressure Level	85 dB(A)
Sound Power Level	96 dB(A)
Dimensions (L x W x H)	w/ BL4025: 457 x 88 x 233 mm (18 x 3-1/2 x 9-1/8") w/ BL4040: 472 x 88 x 239 mm (18-5/8 x 3-1/2 x 9-3/8")
Net weight	4.2 - 4.5 kg (9.3 - 9.9 lbs.)

JR001GM201

JR001GZ



High Cutting Speed

Metal Cutting speed about **10% UP**

ø25.4mm (1") Carbon steel pipe

JR001G	110
18Vx2 Predecessor Model	100
Slow	Fast

Wood Cutting speed about **35% UP**

SPF 2 x 10

JR001G	135
18Vx2 Predecessor Model	100
Slow	Fast

Work amount on a full battery charge* Battery: BL4040	
about 130 pcs ø25.4mm (1") Carbon steel pipe	about 155 pcs SPF 2 x 10



UX01G **NEW**



Li-ion (Ah)
2.0 | 2.5 | 4.0 | 5.0

Max output
1.0kW

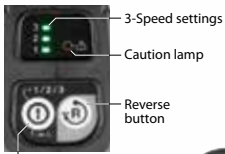

ON / OFF button

Caution lamp



Overload



Overheat



Overdischarge



WG
WET GUARD

High water-resistance allows to operate the machine even if it is wet with water.



DUX60

18V + 18V → 36V

Li-ion (Ah)
1.5 | 2.0 | 3.0 | 4.0 | 5.0 | 6.0

Max output
0.6kW



ON / OFF button

Caution lamp



Overload



Overheat



Overdischarge

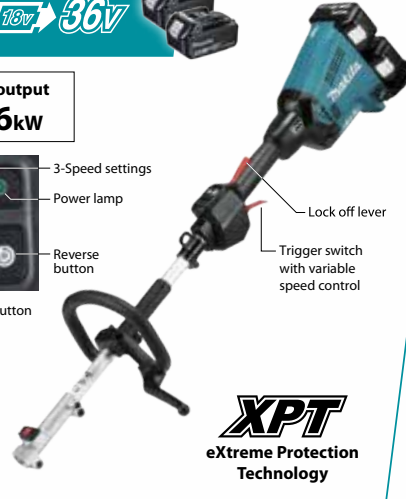

XPT
eXtreme Protection Technology

DUX18 **NEW**

18V LITHIUM-ION

Max output
0.47kW

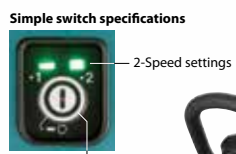

ON / OFF button

Caution lamp



Overload



Overheat



Overdischarge



Features

Reverse button for easy removal of grass clippings from the cutting tool (UX01G / DUX60 only)

Grass clippings can be removed by slow reverse rotation of the cutting tool. After 1.5 seconds, machine stops. Switch position will be returned back to "Forward" automatically after stopping.



Easy change

Lever style lock system allows for quick toolless installation and replacement of the attachments.



Excellent portability

- Split system of Power head and Attachment provides easier portability.
- Optional tool bag makes it even easier to transport Power head and Attachment and to put them into car trunk or small storage space.



Optional attachments



Brushcutter
EM401MP* / EM402MP
EM403MP* / EM404MP*
EM405MP* / EM406MP*

Grass trimmer
EM408MP
EM409MP

*UX01G / DUX60 only



Rotary Scissors
EM407MP



Edger
EE400MP



Pole saw
EY401MP
EY402MP
EY403MP



Hedge trimmer
Straight: EN410MP
Angle adjustment:
EN400MP
EN401MP



Ground trimmer
EN420MP
EN421MP

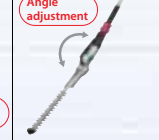

Cultivator
KR400MP
KR401MP



Coffee harvester
EJ400MP



Power brush
BR400MP

UX01G

40Vmax XGT BL AFT Cordless Multi Function Power Head

Cordless Multi Function Power Head



new

- High power BL motor enables to work under heavy load
- WetGuard and IPX4; Excellent water-resistant performance
- Active Feedback sensing Technology (AFT) turns the motor off if rotation speed suddenly slows
- High/Medium/Low 3-speed selection and variable speed control by trigger
- Multi-tool system consisting of power head and versatile optional attachments is ideal for a wide range of applications

XGT BL MOTOR **AFT** **XPT**



No Load Speed (RPM)	High: 0 - 9,700 Medium: 0 - 8,200 Low: 0 - 5,700
Dimensions (L x W x H)	1,027 x 320 x 209 mm (40-1/2 x 12-5/8 x 8-1/4")
Net weight	4.1 - 4.7 kg (9.3 - 10.6 lbs.)

Harness, Safety Goggles, Hex Wrench, Accessory Bag, Tool bag (for spec with Brushcutter attachment only), Carbide-Tipped Saw Blade (for spec with EM402MP only), Box Wrench (for spec with EM402MP / EM403MP / EM404MP only), Metal blade fixing tool (Clamp washer, Nut, Cup) (for spec with EM402MP / EM403MP / EM404MP), Nylon Cutting Head (for spec with EM403MP / EM404MP / EM405MP / EM406MP only), Battery, Charger



BL MOTOR

High Power BL Motor



High power BL motor allows for more comfortable operation in rather heavy-duty application using an attachment such as power brush, power sweep, blower, etc.



Li-ion (Ah)

1.5 | 2.0 | 3.0 | 4.0 | 5.0 | 6.0

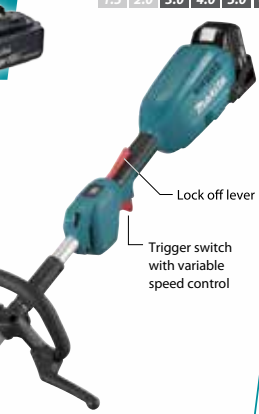

XPT
eXtreme Protection Technology

AFT Active Feedback sensing Technology

Auto-stop occurs while using below attachment, the motor works automatically:
 - Brushcutter with metal blade attachment
 - Pole saw attachment
 - Sensor detects drastically decrease of rotation, motor stops immediately.

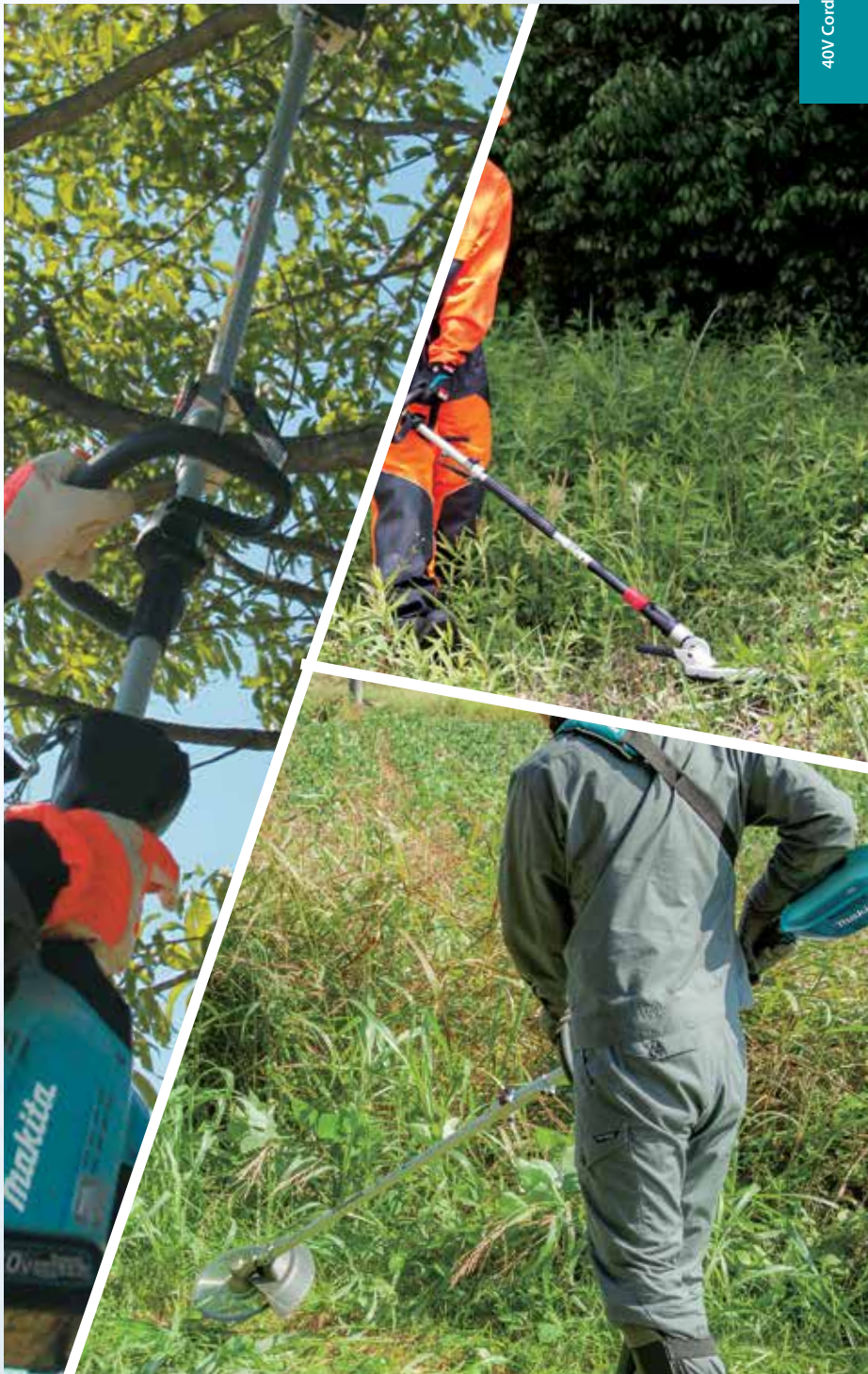
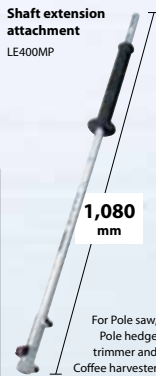
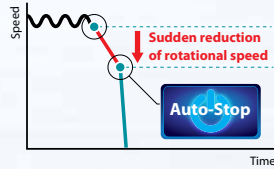

Coffee harvester EJ400MP

Ground trimmer EN420MP

Pole hedge trimmer EN401MP / EN410MP

Pole saw EY401MP EY402MP EY403MP

Cultivator KR400MP KR401MP

Edger EE400MP

Brushcutter EM401MP / EM402MP EM403MP / EM404MP EM405MP / EM406MP EM408MP / EM409MP

Rotary Scissors EM407MP

Power sweep SW400MP

Power brush BR400MP

Blower UB400MP UB401MP

Shaft extension attachment LE400MP

Length: 1,080mm (42-1/2")
 For Pole saw, Pole hedge trimmer and Coffee harvester

Tool ◀▶ Battery ◀▶ Battery Charger
Digital communication

XGT is a new system with its own tools, batteries, and chargers. A combination of innovative tool design and higher output batteries provide a genuine solution for high demand industrial users.

Optimum power supply system and Optimum charging system

The XGT range of tools and batteries come with a built-in program, providing digital communication between the battery and tool. Allowing not only for the battery to talk with tool but also the tool to talk to the battery. Battery technology and motor engineering that work together for optimum performance.

Optimum charging system

Auto maintenance system with two cooling fans for providing more optimum fast charging



Built Tough

High durability specifications specially designed for 40Vmax Li-Ion batteries

4-LED fuel gauge indicator

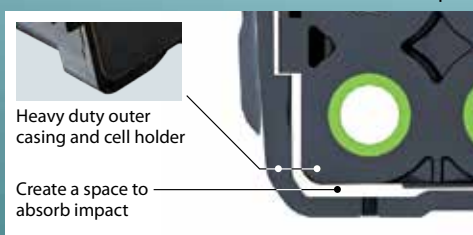

Heavy duty outer casing and cell holder
Create a space to absorb impact

Shock absorption structure

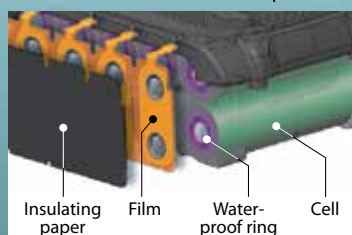

Insulating paper Film Water-proof ring Cell

Waterproof Triple-layer Structure prevents cell failure due to water and dust.



Terminal short-circuit prevention structure
The protection wall is provided between terminals against water and dust.



High Rigidity Battery Rails
Durable slide in battery rail that holds the battery and the tools firmly and securely to withstand high power products

40Vmax mechanism movie

This movie was filmed in Japan.
Models and specs may vary by country.



Rapid Optimum Charging System

It is necessary to cool down before start charging when the battery temperature is high.
Built-in fan circulates air through the battery before start charging and during the charging process to cool the battery for faster charge time.

The Makita Rapid Optimum Charger communicates with the battery's built-in chip throughout the charging process to optimize battery life by actively controlling current, voltage and temperature.

The optimum charging system
Forced air cooling



Fast charging



General charging method
Natural heat dissipation



Waiting time for charging



The optimum charging system

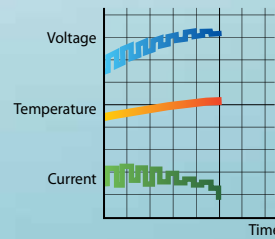

General charging method

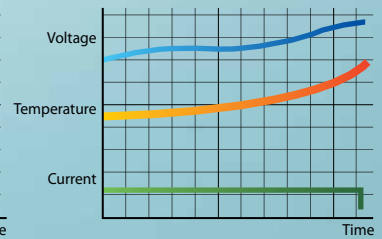

Battery Protection Function

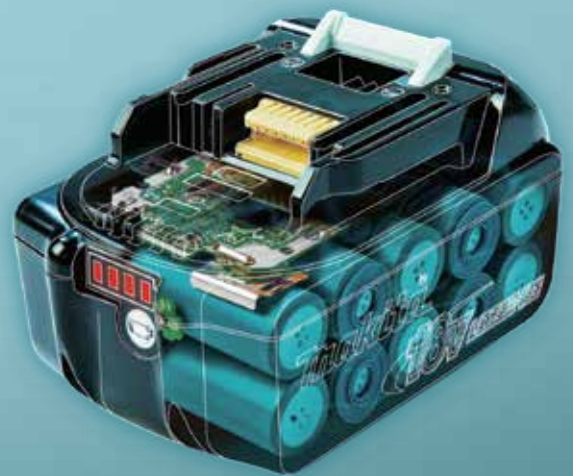
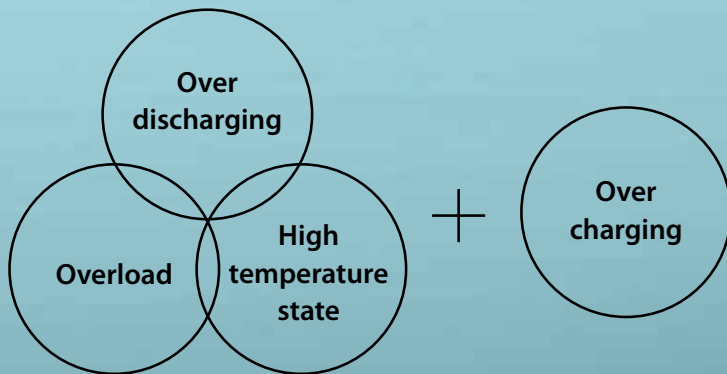

This function is communication technology that allows the tool and battery to monitor conditions and exchange data in real time to protect against Overload, Over-Discharge and Overheating.

Firm Holding

Multi-contact terminals reduce electrical resistance and increase connection stability withstanding against vibration, and ultimately ensures Stable current supply to the tool.







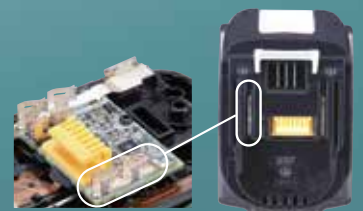





Anytime Charge
No Memory Effect
No discharging required









Shock Absorbing
Heavy Duty Pack



Li-ion Battery & Charging Time Reference, Compatibility Chart

40Vmax 		18V 		Fast Charging DC40RA  DC40RB* 	DC40RC 	Fast Charging DC40RA + ADP10  Compatible with LXT Li-Ion batteries	DC40RC + ADP10  Compatible with LXT Li-Ion batteries	Fast Charging DC18RC  DC18RD*  DC18RE** 	DC18SD  DC18SH* 
XGT 40Vmax Lithium-ion	5.0Ah BL4050F	50min.	85min.	-	-	-	-	-	
	4.0Ah BL4040	45min.	67min.	-	-	-	-	-	
	2.5Ah BL4025	28min.	38min.	-	-	-	-	-	
	2.0Ah BL4020	22min.	30min.	-	-	-	-	-	
LXT 18V Lithium-ion	6.0Ah BL1860B	-	-	40min.	85min.	55min.	130min.		
	5.0Ah BL1850B	-	-	35min.	70min.	45min.	110min.		
	4.0Ah BL1840B	-	-	29min.	58min.	36min.	90min.		
	3.0Ah BL1830B	-	-	22min.	42min.	22min.	60min.		
	2.0Ah BL1820B	-	-	24min.	33min.	24min.	45min.		
	1.5Ah BL1815N	-	-	15min.	22min.	15min.	30min.		

		Fast Charging DC10SB DC18RE** 	DC10WD 	PDC1200 	DC4001 	PDC01 	Power by up to four 18V LXT Batteries
CXT 12Vmax Lithium-ion	4.0Ah BL1041B	60min.	130min.	40Vmax Lithium-ion 18V x2 Lithium-ion 	360min.	18V x2 Lithium-ion 18V Lithium-ion	
	2.0Ah BL1021B	30min.	70min.				
	1.5Ah BL1016	22min.	50min.				

10.8V 		7.2V 		DC10WA 	18V 	14.4V 	DC18WA 
10.8V Lithium-ion	1.3Ah BL1013	50min.		18V Lithium-ion	1.5Ah BL1415G BL1815G	70min.	
7.2V Lithium-ion	1.5Ah BL0715	35min.	14.4V Lithium-ion				

*DC40RB / DC18RD / DC18SH: Two Port Multi Fast Charger
**DC18RE: CXT & LXT Dual port Fast Charger

MAKPAC Power source kit



	Model No.	MAKPAC type	Set contents				
			Battery	Ah	Qty	Charger	Converter
40V_{max} Lithium-ion	MKP1G001	TYPE1	BL4025	2.5Ah	2	DC40RA	
	MKP1G002	TYPE1	BL4040	4.0Ah	2	DC40RA	
18V Lithium-ion	MKP1RT182	TYPE1	BL1850B	5.0Ah	2	DC18RC	
	MKP1RG182	TYPE1	BL1860B	6.0Ah	2	DC18RC	
	MKP3PT184	TYPE3	BL1850B	5.0Ah	4	DC18RD	
	MKP3PG182	TYPE3	BL1860B	6.0Ah	2	DC18RD	
	MKP3PG184	TYPE3	BL1860B	6.0Ah	4	DC18RD	

MAKPAC trolley

able to stack on for easy loading

Part No.
TR00000002
TR00000001(EU)



MAKPAC adapter set

Makita AC Vacuum Cleaner to connect with MAKPAC

Part No.
198730-6
198599-8(EU)

Model No.
VC3211H/M, VC2211M,
VC2201M, VC1310L,
VC2510L, VC3210L



18V LITHIUM-ION



18V Lithium-ion

LXT

18V
LITHIUM-ION

Portable Cut-off

Rear Handle Saw

Recipro Saw

Power Cutter

Rotary Hammer

Slide Compound Miter Saw

Combination Hammer

Angle Grinder

Circular Saw

Shear Wrench

Plunge Cut Saw

Angle Drill

Brad Nailer

Inflator

Fan

Pin Nailer

Finish Nailer

Hole Puncher

Grease Gun

Concrete Vibrator

Wall Scanner

Stapler

Caulking Gun

Wheelbarrow

Vacuum Pump

Flashlight Radio

Rebar Tying Tool

Rivet Gun

Area Worklight

LED Flashlight

LED Worklight

Flashlight

Flashlight

Coffee Maker

Job Site Radio

Job Site Speaker

Fan Jacket

Heated Jacket

Heated Vest

Fan Vest

Heated Blanket

Grass Shear

Blower

Chain Saw

Multi Function Power Head

Robotic Cleaner

Trimmer

Recipro Saw

Hedge Trimmer

Garden Sprayer

Vacuum Cleaner

Portable Vacuum Cleaner

Drywall Saw

Grass Trimmer

String Trimmer

Planer

Belt Sander

Cleaner

Cyclone Cleaner

Cut-Out Tool

Plate Joiner

Jig Saw

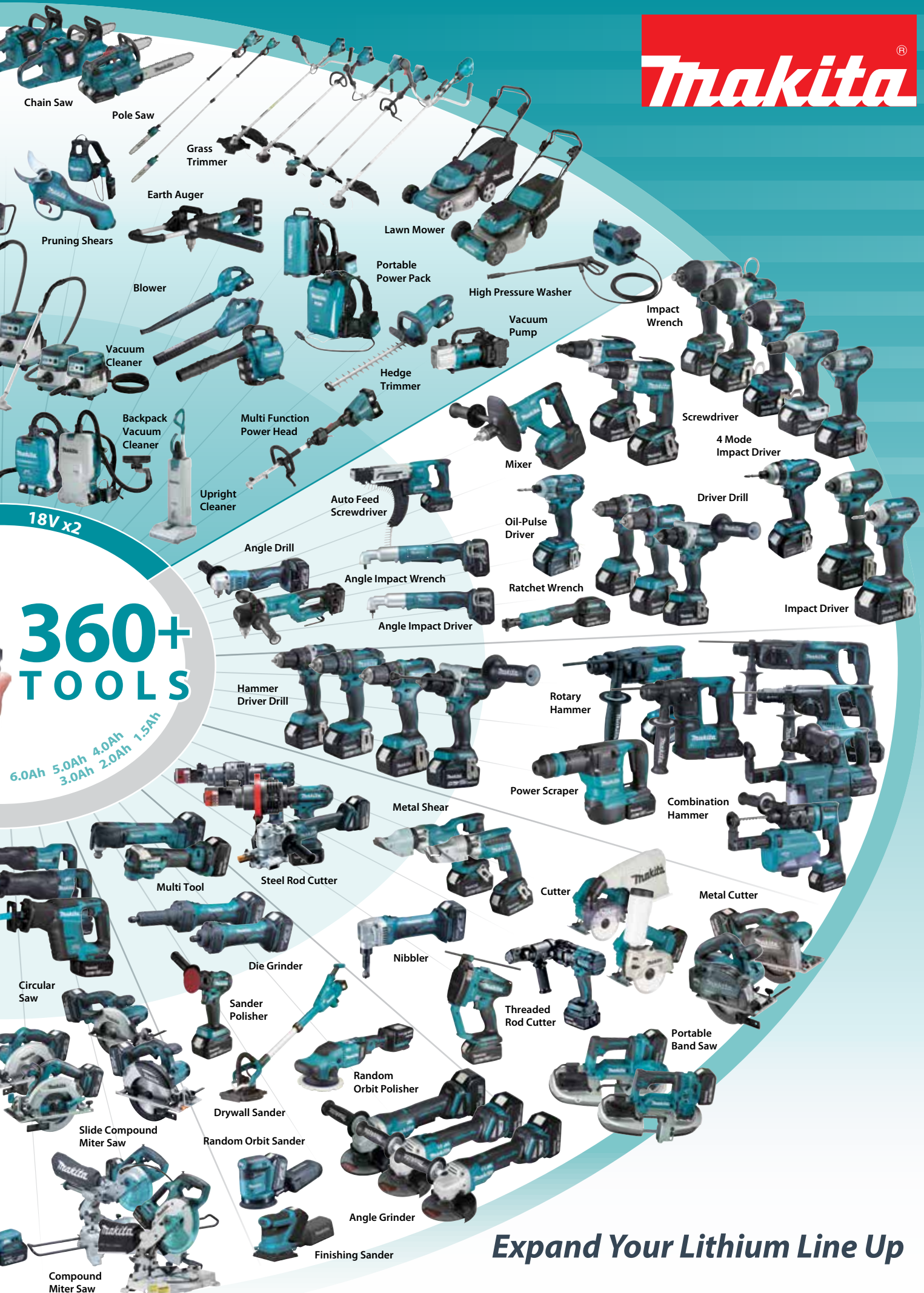

Chain Saw

Pole Saw

Grass Trimmer

Earth Auger

Lawn Mower

Pruning Shears

Portable Power Pack

High Pressure Washer

Blower

Vacuum Pump

Impact Wrench

Vacuum Cleaner

Hedge Trimmer

Screwdriver

Backpack Vacuum Cleaner

Multi Function Power Head

4 Mode Impact Driver

Upright Cleaner

Auto Feed Screwdriver

Mixer

Driver Drill

18V x2

Oil-Pulse Driver

360+ TOOLS

Angle Drill

Angle Impact Wrench

Ratchet Wrench

Impact Driver

Angle Impact Driver

Hammer Driver Drill

Rotary Hammer

6.0Ah 5.0Ah 4.0Ah 3.0Ah 2.0Ah 1.5Ah

Power Scraper

Combination Hammer

Metal Shear

Multi Tool

Steel Rod Cutter

Cutter

Metal Cutter

Circular Saw

Die Grinder

Nibbler

Threaded Rod Cutter

Sander Polisher

Random Orbit Polisher

Portable Band Saw

Drywall Sander

Random Orbit Sander

Angle Grinder

Finishing Sander

Slide Compound Miter Saw

Compound Miter Saw

Expand Your Lithium Line Up

This movie was filmed in Japan.
Models and specs may vary by country.



18V X2 Lithium-ion

Powered by two 18V Li-ion batteries in series

18v + 18v → 36v LXT

EXPAND YOUR LITHIUM-ION LINEUP



Lawn Mower
DLM382 / DLM432 / DLM460 / DLM462 /
DLM463 / DLM465 / DLM530 / DLM532 /
DLM533 / DLM534 / DLM536 / DLM537

Chain Saw
DUC405 / DUC400 / DUC355 /
DUC353 / DUC305 / DUC303 /
DUC256 / DUC306 / DUC356 /
DUC406

High Pressure Washer
DHW080

Blower
DUB361 / DUB362 /
DUB363

Grass Trimmer
DUR364L / DUR368A /
DUR368L / DUR369A /
DUR369L / DUR369N

Pole Saw
DUA250 / DUA251 /
DUA300 / DUA301

Multi Function Power Head
DUX60

Battery Powered Pruning Shears
DUP361 / DUP362

Earth Auger
DDG460

Backpack Vacuum Cleaner
DVC261 / DVC265 / DVC660 /
DVC665

Upright Cleaner
DVC560

Shear Wrench
DWT310

Angle Drill
DDA460

Combination Hammer
DHR263 / DHR264 /
DHR280, DHR282+DX08 /
DHR281, DHR283+DX09

Rotary Hammer
DHR400N

Slide Compound Miter Saw
DLS714 / DLS110 / DLS111 /
DLS112 / DLS211 / DLS212

Power Cutter
DCE090

Rear Handle Saw
DR5780

Recipro Saw
DJR360

Circular Saw
DHS710 / DHS711 / DHS781
/ DHS780 / DHS782 /
DHS783 / DHS900 / DHS901

Plunge Cut Saw
DSP600 / DSP601

Portable Cut-off
DLW140

Vacuum Cleaner
DVC865L / DVC866L / DVC867L /
DVC155L / DVC156L / DVC157L

Corded and Cordless Vacuum Cleaner
DVC860L / DVC861L / DVC150L /
DVC151L

Portable Power Pack
PDC1200

Equipped with built-in battery cells

Adapter set

Portable Power Pack
PDC01

Adapter set

Battery Adapter
BAP182

- Items of standard equipment and specifications may vary by country or area. - Net weight and dimensions may differ by the type of battery. - Battery runtime may vary as per the application.

Cordless Portable Cut-off

DLW140

World's First Cordless Portable Cut-off



Toolless replacement of abrasive cut-off wheel



Quick release vise

BL MOTOR

High Power and High Speed

Cutting work Amount

130cuts

75 x 45mm, T : 0.8mm metal stud
BL1850B x2

Large spark guard



Load status indicator



As the motor load increases, the lighting lamp increases.

Toolless adjustment of guide plate



allows for easy adjustment of the guide plate by simple handling

- 3 stage position change
- 0 to 45 degree angle adjustment

Saw head locking by pin lock



makes it easy to lock down the saw head for storage and transport.

Carry handle



for easy transport to job site

DLW140

Cordless Portable Cut-off

18V X2 (36V) LXT BL 355 mm (14") Toolless Portable Cut-Off

- World's First Cordless Portable Cut-off
- Cuts 130 metal studs with BL1850B x2
- Electric brake allows adjustments to be completed faster for maximum productivity
- Load status indicator shows the load level on the motor during cutting operation
- Suitable for light duty application, such as cutting metal studs



LXT BL MOTOR



Cut-Off Wheel, Battery, Charger

Wheel Diameter	355 mm (14")
Hole Diameter	25.4 mm (1")
No Load Speed (RPM)	3,800
Capacity at 90°	Round: 127 mm (5") Rectangular: 115x130 mm (4-1/2"x5-1/8") Rectangular: 102x194 mm (4"x7-5/8")
Capacity at 45°	Round: 127 mm (5") Rectangular: 70x233 mm (2-3/4"x9-1/8") Rectangular: 115x103 mm (4-1/2"x4-1/16")
Vibration Level	2.5 m/s ²
Sound Pressure Level	103 dB(A)
Sound Power Level	115 dB(A)
Dimensions (L x W x H)	w/ European type safety guard: 537x290x640 mm (21-1/8"x11-3/8"x25-1/4") 21-1/8"x11-3/8"x25-1/4")
Net weight	17.2 - 17.8 kg (37.9 - 39.3 lbs.)

DLW140PT2
DLW140Z

Cordless Circular Saw

DHS900 / DHS783 / DHS780

High power for fast cutting and ripping

18VX2 Cordless

Rotatable dust nozzle

model: DHS900, DHS901

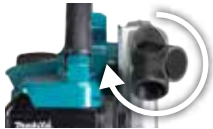

Compatible with Guide rail without adapter, providing precision cutting

Model: DHS900, DHS783, DHS780

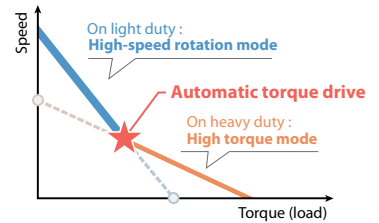

photo: DHS900

ADT Automatic torque Drive Technology

automatically changes the cutting speed according to load conditions for an optimum operation:

- On light duty: high-speed rotation mode
- On heavy duty: high torque mode



AWS Auto-start Wireless System

model: DHS900, DHS901, DHS783, DHS781

The wireless activation function enables clean and comfortable operation. By connecting a supported tool to the cleaner, you can run the cleaner automatically along with the switch operation of the tool.

DHS900

Cordless Circular Saw

18V X2 (36V) LXT BL AWS ADT Cordless 235 mm (9-1/4") Magnesium Circular Saw, Electric Brake, Soft Start, Twin LED Light



new

- Cordless mobility allows for smooth operation without worrying about cord handling even in cutting long material
- 18V X2 LXT Li-Ion batteries, BL motor and TCT saw blade optimum for DC circular saw deliver powerful and smooth cutting similar to corded tool
- Lightweight by BL motor, magnesium diecast base, blade case, etc. (DHS900 only)
- 18V solution for corded power demands
- Compatible with guide rail without adapter, providing precision cutting (DHS900 only)
- Two 18V LXT Li-Ion batteries deliver the power and performance for corded demands without leaving the 18V LXT platform



LXT BL MOTOR AWS ADT (BRAKE) XPT



Wireless Unit (country-specific), TCT Saw Blade, Sub Base(DHS900 only),

Blade Diameter	235 mm (9-1/4")
Max Cutting Capacity	90°: 85 mm (3-3/8") 45°: 61 mm (2-3/8") 60°: DHS900: 44 mm (1-3/4") / DHS901: 41 mm (1-5/8")
No Load Speed (RPM)	4,500
Vibration Level	Cutting Wood: 2.5 m/s ² or less Cutting Metal: 2.5 m/s ² or less
Sound Pressure Level	93 dB(A)
Sound Power Level	104 dB(A)
Dimensions (L x W x H)	DHS900: 413x196x316 mm (16-1/4"x7-3/4"x12-1/2")
Net weight	DHS900: 5.3 - 6.0 kg (11.7 - 13.2 lbs.)

DHS900PT2
DHS900Z

DHS783

Cordless Circular Saw

18V X2 (36V) LXT BL AWS ADT Cordless 190/185 mm (7-1/2" / 7-1/4") Magnesium Circular Saw, Electric Brake, Soft Start, Dual LED Light



- 6,000 RPM for fast cutting
- 18V solution for corded power demands
- Two 18V LXT Li-Ion batteries deliver the power and performance for corded demands without leaving the 18V LXT platform
- BL motor delivers 6,000 RPM for fast cutting
- BL motor eliminates carbon brushes, enabling the BL motor to run cooler and more efficiently for longer life
- Large cutting capacity (62.5 mm at 90°) and bevel capacity (0° - 48°) with a positive stop at 45°



LXT BL MOTOR AWS ADT (BRAKE) XPT



Wireless Unit (country-specific), TCT Saw Blade, Dust Nozzle, Hex Wrench, Guide Rule, Hook, Battery, Charger

Blade Diameter	190 / 185 mm (7-1/2" / 7-1/4")
Max Cutting Capacity	90°: 62.5 / 60 mm (2-7/16" / 2-3/8") 45°: 44.5 / 43 mm (1-3/4" / 1-11/16") 48°: 42 / 41 mm (1-5/8" / 1-5/8")
No Load Speed (RPM)	6,000
Vibration Level	Cutting Wood: 2.5 m/s ² or less Cutting Metal: 2.5 m/s ² or less
Sound Pressure Level	93 dB(A)
Sound Power Level	104 dB(A)
Dimensions (L x W x H)	348x210x290 mm (13-3/4"x8-1/4"x11-3/8")
Net weight	4.5 - 5.1 kg (9.9 - 11.3 lbs.)

DHS783T2JU
DHS783PT2J

DHS783ZU
DHS783Z

DHS780

Cordless Circular Saw

18V X2 (36V) LXT BL ADT Cordless 190/185 mm (7-1/2" / 7-1/4") Magnesium Circular Saw, Electric Brake, Soft Start, Dual LED Light



- 6,000 RPM for Fast Cutting
- 18V solution for corded power demands
- Two 18V LXT Li-Ion batteries deliver the power and performance for corded demands without leaving the 18V LXT platform
- BL motor delivers 6,000 RPM for fast cutting
- BL motor eliminates carbon brushes, enabling the BL motor to run cooler and more efficiently for longer life



LXT BL MOTOR ADT (BRAKE) XPT



TCT Saw Blade, Dust Nozzle, Hex Wrench, Battery, Charger

Blade Diameter	190 / 185 mm (7-1/2" / 7-1/4")
Max Cutting Capacity	90°: 68.5 / 66 mm (2-11/16" / 2-5/8") 45°: 47.5 / 45.5 mm (1-7/8" / 1-13/16") 56°: 35.5 / 34 mm (1-3/8" / 1-5/16")
No Load Speed (RPM)	6,000
Vibration Level	Cutting Wood: 2.5 m/s ² or less Cutting Metal: 2.5 m/s ² or less
Sound Pressure Level	93 dB(A)
Sound Power Level	104 dB(A)
Dimensions (L x W x H)	342x200x290 mm (13-1/2"x7-7/8"x11-3/8")
Net weight	4.2 - 4.8 kg (9.3 - 10.7 lbs.)

DHS780PT2J
DHS780Z

DHR282 / DHR280

Cordless Combination Hammer

18V X2 (36V) LXT BL AVT SOFT NO LOAD Cordless 28 mm (1-1/8") Combination Hammer, SDS-PLUS Bits



- BL Motor & AVT + SOFT NO LOAD Functions Deliver High Power and Low Vibration
- Auto-start Wireless System (AWS) connects to vacuum cleaner with Bluetooth (DHR282)
- Active Feedback sensing Technology (AFT) turns the motor off if bit rotation is suddenly forced to stop (DHR282)
- 18V solution for corded power demands



Side Grip, Depth Gauge, Battery, Charger, Dust Cup (country-specific), Cleaning cloth (country-specific), Bit Grease (country-specific)

Impact Energy Capacity	EPTA-Procedure 05/2009: 2.8 J Concrete / Steel / Wood / Core Bit / Diamond Core Bit (Dry Type): 28 / 13 / 32 / 54 / 65 mm (1-1/8" / 1/2" / 1-1/4" / 2-1/8" / 2-9/16")
Blows Per Minute (BPM)	0 - 5,000
No Load Speed (RPM)	0 - 980
Chuck Capacity	1.5 - 13 mm (1/16 - 1/2")
Vibration Level	Hammer Drilling into Concrete: 9.0 m/s ² Hammer Drilling into Concrete w/ DX08: 8.0 m/s ² Drilling Into Metal: 2.5 m/s ²
Sound Pressure Level	93 dB(A)
Sound Power Level	104 dB(A)
Sound Pressure Level w/ DX08	92 dB(A)
Sound Power Level w/ DX08	103 dB(A)
Dimensions (L x W x H)	373x134x232 mm (14-3/4"x5-1/4"x9-1/8")
Net weight	DHR282: 3.9 - 5.0 kg (8.6 - 11.0 lbs.), DHR280: 3.9 - 4.9 kg (8.6 - 10.8 lbs.)

DHR282PT2 - Rs. 75,000 DHR280PT2 - Rs. 68,000
DHR282Z - Rs. 40,000 DHR280Z - Rs. 32,000

DWT310

Cordless Shear Wrench

18V X2 (36V) LXT BL Brushless Cordless M16 (5/8") / M20 (3/4") / M22 (7/8") 804 N-m (593 ft.lbs.) Shear Wrench



- Up to 14% Faster Fastening than Corded Model 6922NB
- Fastens 380 M22 (7/8") torque shear bolts with two 18V 6.0 Ah batteries
- 18V solution for corded power demands
- Two 18V LXT Li-Ion batteries deliver the power and run time for corded demands without leaving the 18V LXT platform
- High power delivered by 36V (18Vx2) DC Brushless motor enables to fasten as fast as if you were using a corded shear wrench



- Screwdriver, Shoulder Belt, Battery, Charger

Capacity	High Strength Torque Shear Bolt (HTB): M16, M20, M22 (5/8", 3/4", 7/8") Super High Strength Torque Shear Bolt (SHTB): M16, M20 (5/8", 3/4")
No Load Speed (RPM)	14
Max Fastening Torque	804 N-m (593 ft.lbs.)
Vibration Level	2.5 m/s ² or less
Sound Pressure Level	83 dB(A)
Sound Power Level	94 dB(A)
Dimensions (L x W x H)	296x130x377 mm (11-5/8"x5-1/8"x14-7/8")
Net weight	6.5 - 7.1 kg (14.3 - 15.7 lbs.)

DWT310PT2
DWT310ZK

DGA901

Cordless Angle Grinder

18V X2 (36V) LXT BL Cordless 230 mm (9") Angle Grinder, Anti-Restart Function, Electric Brake, Large Trigger Switch



- Auto-Start Wireless System (AWS) Connects to Compatible Vacuum Cleaners with Bluetooth (DGA901)
- 18V Solution for Corded Power Demands
- Two 18V LXT Li-Ion batteries deliver the power and performance for corded demands without leaving the 18V LXT platform
- ADT (Automatic torque Drive Technology) adjusts speed and torque during operation for optimum performance
- AFT (Active Feedback sensing Technology) turns the motor off if rotation speed suddenly slows or wheel is forced to stop



Toolless Wheel Cover / Wheel Cover, Side Grip, Lock Nut Wrench

Wheel Diameter	230 mm (9")
Hole Diameter	22.23 mm (7/8")
No Load Speed (RPM)	6,000
Circumference of grip	160 mm (6-5/16")
Vibration Level	Surface Grinding w/ Anti-Vibration Side Grip: 7.5 m/s ² Disc Sanding w/ Anti-Vibration Side Grip: 2.5 m/s ² or less
Sound Pressure Level	88 dB(A)
Sound Power Level	99 dB(A)
Dimensions (L x W x H)	499x250x158 mm (19-5/8"x9-7/8"x6-1/4")
Net weight	5.2 - 8.0 kg (11.4 - 17.7 lbs.) 5.2 - 8 kg (11.46 - 17.64 lbs.)

DGA901PT2
DGA901Z

DGA701 / DGA700

Cordless Angle Grinder

18V X2 (36V) LXT BL Cordless 180 mm (7") Angle Grinder, Anti-Restart Function, Electric Brake, Large Trigger Switch



- Auto-Start Wireless System (AWS) Connects to Compatible Vacuum Cleaners with Bluetooth (DGA701)
- 18V Solution for Corded Power Demands
- Two 18V LXT Li-Ion batteries deliver the power and performance for corded demands without leaving the 18V LXT platform
- ADT (Automatic torque Drive Technology) adjusts speed and torque during operation for optimum performance
- AFT (Active Feedback sensing Technology) turns the motor off if rotation speed suddenly slows or wheel is forced to stop



Toolless Wheel Cover / Wheel Cover, Side Grip, Lock Nut Wrench

Wheel Diameter	180 mm (7")
Hole Diameter	22.23 mm (7/8")
No Load Speed (RPM)	7,800
Circumference of grip	DGA701: 160 mm (6-5/16")
Vibration Level	Surface Grinding w/ Anti-Vibration Side Grip: 7.5 m/s ² Disc Sanding w/ Anti-Vibration Side Grip: 2.5 m/s ² or less
Sound Pressure Level	88 dB(A)
Sound Power Level	99 dB(A)
Dimensions (L x W x H)	499x200x158 mm (19-5/8"x7-7/8"x6-1/4")
Net weight	DGA701: 5.0 - 6.0 kg (11.0 - 13.3 lbs.) DGA700: 5 - 6 kg (11.02 - 13.23 lbs.)

DGA700PT2 DGA701PT2
DGA701Z DGA701Z

DLS111

Cordless Slide Compound Miter Saw

18V X2 (36V) LXT BL AWS ADT Cordless 260 mm (10-1/4") Slide Compound Miter Saw, Laser



- Auto-Start Wireless System (AWS) Connects to Compatible Vacuum Cleaners with Bluetooth
- Rail-forward design enables to be placed against a wall for maximizing work space
- 18V solution for corded power demands
- Two 18V LXT Li-Ion batteries deliver the power and run time for corded demands without leaving the 18V LXT platform
- High power delivered by 36V (18Vx2) DC Brushless motor enables to cut as fast as if you were using a corded slide compound miter saw



TCT Saw Blade, Dust Bag, Triangular Rule, Vertical Vise, Hex Wrench

Blade Diameter	260 mm (10-1/4")
Miter Angle	60° L / 60° R
Bevel Angle	48° L / 48° R
Max Cutting Capacity	90° Miter: 91 x 279 mm (3-5/8" x 11") 90° Miter: 68 x 310 mm (2-11/16" x 12-1/4") 45° Miter, L/R: 91 x 197 mm (3-5/8" x 7-3/4") 45° Miter, L/R: 68 x 218 mm (2-11/16" x 8-5/8")
No Load Speed (RPM)	4,400
Sound Pressure Level	92 dB(A)
Sound Power Level	102 dB(A)
Vibration Level	2.5 m/s ² or less
Dimensions (L x W x H)	805x644x660 mm (31-3/4"x25-3/8"x26")
Net weight	26.6 - 27.3 kg (58.6 - 60.2 lbs.)

DLS111ZU

DLS211

18V X2 (36V) LXT BL AWS ADT Cordless 305 mm (12") Slide Compound Miter Saw, Laser

Cordless Slide Compound Miter Saw



- 18V solution for corded power demands
- Two 18V LXT Li-Ion batteries deliver the power and run time for corded demands without leaving the 18V LXT platform
- High power delivered by 36V (18Vx2) DC Brushless motor enables to cut as fast as if you were using a corded slide compound miter saw
- Automatic torque Drive Technology (ADT) adjusts speed and torque during operation for optimum performance



LXT BL AWS ADT DXT



TCT Saw Blade, Dust Bag, Holder Set, Vertical Vise, Hex Wrench, Triangular Rule

Blade Diameter	305 mm (12")
Miter Angle	60° L / 60° R
Bevel Angle	48° L / 48° R
Max Cutting Capacity	90° Miter: 107 x 363 mm (4-1/4" x 14-1/4") 90° Miter: 92 x 382 mm (3-5/8" x 15") 45° Miter, L/R: 107 x 255 mm (4-1/4" x 10") 45° Miter, L/R: 92 x 268 mm (3-5/8" x 10-1/2")
No Load Speed (RPM)	4,400
Sound Pressure Level	1,500 W
Sound Power Level	103 dB(A)
Vibration Level	2.5 m/s ² or less
Dimensions (L x W x H)	898x690x725 mm (35-1/4"x27-1/4"x28-1/2")
Net weight	30.7 - 31.3 kg (67.6 - 69.1 lbs.)

DLS211P2T

DLS211Z

DLS714

18V X2 (36V) LXT BL ADT Cordless 190 mm (7-1/2") Dual Slide Compound Miter Saw

Cordless Slide Compound Miter Saw



- 18V solution for corded power demands
- Two 18V LXT Li-Ion batteries deliver the power and performance for corded demands without leaving the 18V LXT platform
- High power delivered by 36V (18Vx2) DC Brushless motor enables to cut as fast as if you were using a corded slide compound miter saw
- Large cutting capacity; Crosscuts up to 52 x 300 mm (2-1/16" x 11-3/4") at 90°
- Miters 0-47° left and 0-57° right; bevels 0-45° left and 0-5° right



LXT BL ADT



TCT Saw Blade, Dust Bag, Holder Set, Vertical Vise, Hex Wrench, Triangular Rule

Blade Diameter	190 mm (7-1/2")
Miter Angle	47° L / 57° R
Bevel Angle	45° L / 5° R
Max Cutting Capacity	90°: 52 x 300 mm (2-1/16" x 11-3/4") at 45° left: 40x300 mm (1-9/16"x11-3/4") at 5° right: 40x300 mm (1-9/16"x11-3/4")
No Load Speed (RPM)	5,700
Sound Pressure Level	88 dB(A)
Sound Power Level	97 dB(A)
Vibration Level	2.5 m/s ² or less
Dimensions (L x W x H)	655x430x445 mm (25-3/4"x17"x17-1/2")
Net weight	12.6 kg (27.8 lbs.)

DLS714Z

DSP600

18V X2 (36V) LXT BL Cordless 165 mm (6-1/2") Plunge Cut Saw

Cordless Plunge Cut Saw



- Auto-start Wireless System (AWS) Connects to Vacuum Cleaner with Bluetooth (DSP601)
- Up to 80% faster cutting than corded model SP6000
- Automatic torque Drive Technology (ADT) adjusts cutting speed and torque during cut for optimum performance
- 18V solution for corded power demands
- Two 18V LXT Li-Ion batteries deliver the power and performance for corded demands without leaving the 18V LXT platform



LXT BL ADT (BRAKE)



TCT Saw Blade, Hex Wrench, country-specific)

Blade Diameter	165 mm (6-1/2")
Bevel Capacity	-1° - 48°
Max Cutting Capacity	90°: 56 mm (2-3/16") 45°: 40 mm (1-9/16") 48°: 38 mm (1-1/2")
No Load Speed (RPM)	2,500 - 6,300
Sound Pressure Level	92 dB(A)
Sound Power Level	103 dB(A)
Vibration Level	Cutting Wood: 2.5 m/s ² or less Cutting Metal: 2.5 m/s ² or less
Dimensions (L x W x H)	346x241x272 mm (13-5/8"x9-1/2"x10-3/4")
Net weight	4.4 - 5.1 kg (9.8 - 11.2 lbs.)

DSP600Z

DJR360

18V X2 (36V) LXT BL Brushless Cordless Recipro Saw

Cordless Recipro Saw



- Our most powerful cordless reciprocating saw yet: Amazing work amount and work efficiency
- Higher cutting speed (Max 3,000 SPM) and modified stroke length (32 mm) provide higher cutting efficiency
- Newly designed vertical crank mechanism minimizes blade deflection and reduces vibration to machine
- Higher durability thanks to More durable mechanism to hold slider and More rigid shoe
- Two 18V LXT Li-Ion batteries deliver the power and run time for corded demands without leaving the 18V LXT platform



LXT BL XPT



Recipro Saw Blades

Length of Stroke	32 mm (1-1/4")
Strokes Per Minute (SPM)	High / Low: 0 - 3,000 / 0 - 2,300
Capacity	Pipe: 130 mm (5-1/8") Wood: 255 mm (10")
Vibration Level	Cutting Boards: 16.5 m/s ² Cutting Wooden Beams: 15.5 m/s ²
Sound Pressure Level	85 dB(A)
Sound Power Level	96 dB(A)
Dimensions (L x W x H)	449x116x243 mm (17-3/4"x4-9/16"x9-9/16")
Net weight	4.0 - 4.7 kg (8.9 - 10.3 lbs.)

DJR360Z

DCE090

18V X2 (36V) LXT BL AFT Cordless 230 mm (9") Power Cutter, Electric Brake

Cordless Power Cutter

new



- Max Cutting Capacity: 88 mm
- 230 mm Diamond wheel ideal for cordless power cutter; New diamond wheel with even pattern placement of diamond grits; The grit arrangement provides sharp cutting edge constantly
- Active Feedback sensing Technology (AFT) turns the motor off if rotation speed suddenly slows or wheel is forced to stop
- LED job light enables operation in the dark sites where electricity is not supplied; can be turned on/off by pushing the button conveniently located on the top of the tool
- Battery cover protects battery from water in wet cutting



LXT BL AFT (BRAKE) XPT



Hex Wrench, Wrench, Coupling Sleeve, Battery, Charger

Wheel Diameter	230 mm (9")
Max Cutting Capacity	88 mm (3-1/2")
No Load Speed (RPM)	6,600
Vibration Level	Left / Right: 5.9 / 4.0 m/s ²
Sound Pressure Level	103 dB(A)
Sound Power Level	114 dB(A)
Dimensions (L x W x H)	554 x 241 x 283 mm (21-3/4" x 9-1/2" x 11-1/8")
Net weight	5.6 - 6.3 kg (12.3 - 13.9 lbs.)

DCE090T2X1

DCE090Z1

Cordless Earth Auger

DDG460

new

Battery Powered and Powerful



Reversing switch
enables to extract, in reverse rotation mode, an auger bit jammed in soil with high resistance like clay soil.

Torque limiter
The torque limiter will actuate when a certain torque level is reached at the low speed setting. The motor will disengage from the output shaft. When this happens, the drill bit will stop turning.

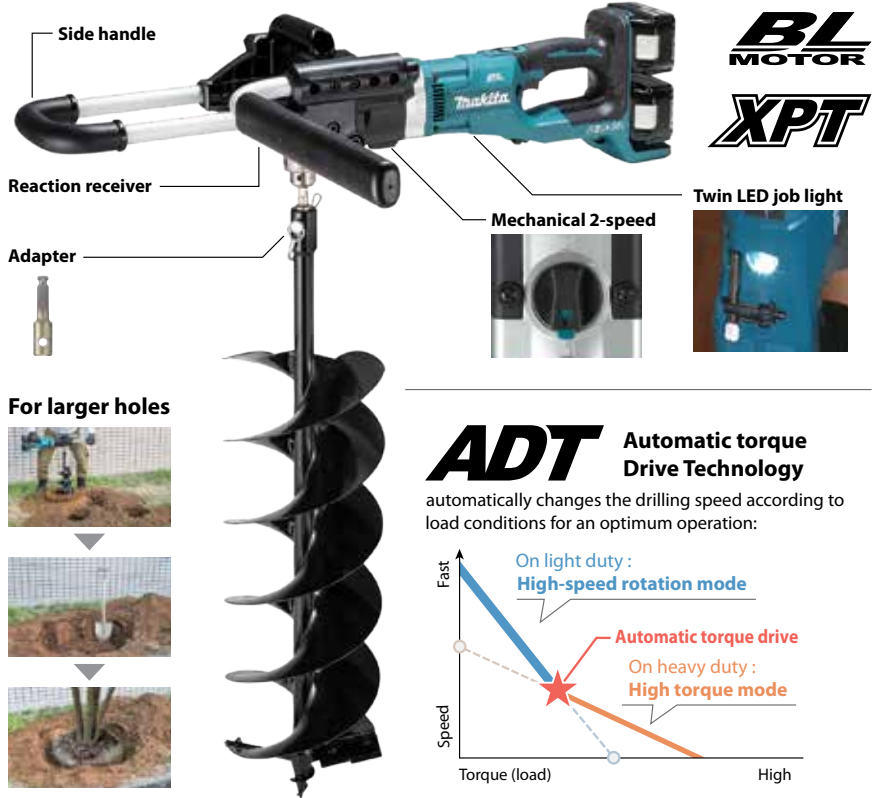

For larger holes

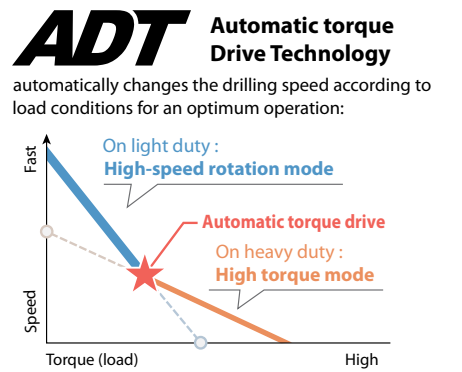

DDG460 18V X2 LXT BL Cordless Earth Auger

Cordless Earth Auger

new

- Earth auger attachment includes a bar which receives reaction force and an auxiliary handle, and helps the user drill holes in the ground easier
- Reversing switch enables to extract, in reverse rotation mode, an auger bit jammed in soil with high resistance like clay soil
- Lightweight design for reduced operator fatigue
- Auger bit adapter enables to use the auger bits for popular engine earth augers
- BL motor delivers 1,400 RPM

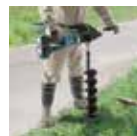

LXT BL MOTOR ADT XPT



Chuck Key, Hex Wrench, Adapter, Battery, Charger

Capacity	Sandy Soil: 200 mm Clay Soil: 150 mm
No Load Speed (RPM)	High / Low: 0 - 1,400 / 0 - 350
Max Fastening Torque	High: 48 N-m (430 in.lbs.) Low: 136 N-m (1,210 in.lbs.)
Vibration Level	2.5 m/s ² or less
Sound Pressure Level	85 dB(A)
Sound Power Level	96 dB(A)
Dimensions (L x W x H)	840 x 607 x 223 mm (33 x 23-7/8 x 8-3/4")
Net weight	7.3 - 8.2 kg (16.1 - 18.1 lbs.)

DDG460ZX8

DDA460 18V X2 LXT BL ADT Cordless 13 mm (1/2") Angle Drill with Keyed Chuck

Cordless Angle Drill

- Amazing High Power
- High-speed drilling beyond AC tool
- Powerful drilling even large diameter holes
- Exceptional high power and high speed
- 18V solution for corded power demands



LXT BL MOTOR ADT XPT



Chuck Key, Hex Wrench, Side Grip

Capacity	Steel: 13 mm (1/2") Wood (Self-feed bit) : 118 mm (4-5/8") Wood (Hole saw) : 159 mm (6-1/4")
No Load Speed (RPM)	High: 0 - 1,400 Low: 0 - 350
Max lock torque	High: 136N-m Low: 48N-m
Vibration Level	Drilling Into Metal: 2.5 m/s ² or less
Sound Pressure Level	85 dB(A)
Sound Power Level	96 dB(A)
Dimensions (L x W x H)	538x128x223mm (21-1/4"x5"x8-3/4")
Net weight	5.7-6.4 kg (12.6-14.0 lbs)

DDA460PT2
DDA460ZK

18v + 18v → 36v

Li-Ion Ah 6.0 5.0 4.0 3.0 2.0 1.5

Battery & charger time reference chart P.20

Cordless Upright Cleaner

DVC560

new

Ideal for carpet cleaning



Max air flow

1.9 m³/min

Max Sealed Suction

12 kPa

18v + 18v → 36v

High dust pick-up rate

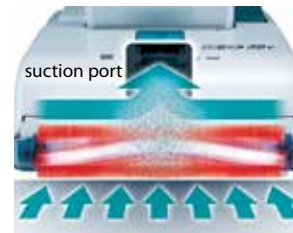

4 rows of V-shaped bristle increase dust pick-up rate.



Suction power is even across the entire cleaning width due to the suction port located at the center.

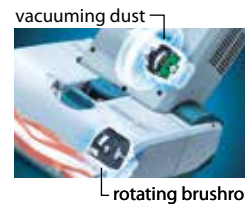

Two different BL motors

- One for vacuuming dust and the other for rotating brushroll
- Two motors are separately controlled according to the selected suction mode.

+

allows for use in noise-sensitive environments such as office, hospital and more.

Low noise mode **57 dB(A)**

Max mode: 67dB(A) / Normal mode: 64dB(A)

Long run time



Continuous use on a full battery charge*

Max about **30 min**

High about **60 min**

Low noise about **120 min**

*with BL1860B x2

4-stage brushroll height adjustment

4-stage manually adjustable to carpet pile length



Main body able to tilt up to 90 degrees

enables to clean in tight spaces under furniture, sofa, bed and more.



Accessories

Long sash nozzle set
Part No. 191D65-8



Round brush set
Part No. 191D67-4



Brush complete set
Part No. 191D69-0



Main filter h set
Part No. 191E39-5



Filter bag set
10pcs. set
Part No. 191D63-2



DVC560

18V X2 (36V) LXT BL Brushless Cordless 5 L HEPA Upright Cleaner

Cordless Upright Cleaner



new

- High dust removal performance similar to corded upright cleaners
- Low noise mode allows for use in noise-sensitive environments such as office, hospital and more
- Two different BL motors, one for vacuuming dust and the other for rotating brushroll
- One-touch 3-suction mode selection switch with mode memory function
- 4-stage brushroll height adjustment

LXT BL MOTOR



Long Sash Nozzle, Round Brush, Filter Bag, Filter H, Filter Bag Set

Capacity	Dust / Water: 5 / L
Continuous Use (min.)	w/ BL1860B x2 Max / Normal / Low Noise : 30 / 60 / 120
Max Air Flow	1.9 m ³ /min
Max Sealed Suction	12 kPa
Suction Power	Max / Normal / Low Noise: 85 / 50 / 25 W
Dust Pick-Up Rate	Max / Normal / Low Noise: 47 / 44 / 40
Cleaning Width	318 mm
Brushroll Rotation Speed	Max / Normal / Low Noise : 3,500 / 2,500 / 1,000 RPM
Dimensions	326 x 318 x 1,146 mm
(L x W x H)	(12-7/8 x 12-1/2 x 45")
Net weight	8.3 - 9.0 kg (18.3 - 19.8 lbs.)

DVC560Z



Cleaning mechanism of paper dust bag for work efficiency (DVC660 / DVC665 only)

Even when vacuuming concrete dust tending to clog filters, actuation of this mechanism allows to collect approximately up to 4.0L, 70% of the paper dust bag capacity. (approximately 3.0L [50%] when not actuated)



This mechanism can be actuated:

- Automatically by the vibration due to walking
- Manually by operating a lever by hand

Side Battery (DVC660 / DVC660 only)



HEPA filter Exhaust air is as clean as that of air cleaner.

HEPA Filter is used as the main filter to capture very fine particles effectively.

Able to capture 99.97% of particles as small as 0.3-1 μm

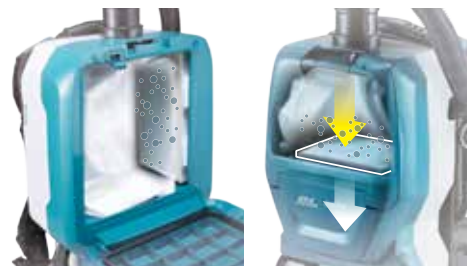

DVC660 / DVC665

DVC261 / DVC265

Controller

DVC660 / DVC261

DVC665 / DVC265 **AWS**

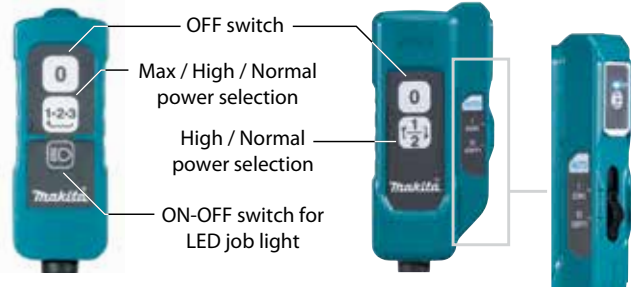

DVC660

18V X2 (36V) LXT BL Brushless HEPA Cordless Backpack Vacuum Cleaner

Cordless Backpack Vacuum Cleaner



new

- Cleaning mechanism for paper dust bag
- Increased suction power for improved dust collection
- BL motor allows 2.2 m³/min of Max air flow / 11 kPa of Max sealed suction and long run time
- Mode memory function allows to start in the same suction power when you turned it off previously
- Delivers up to 140 min of run time using BL1860B on normal setting



LXT BL MOTOR



Floor Nozzle, Hose, Hose Band, Nozzle assembly, Telescopic pipe assembly, Bent Pipe, Switching nozzle, Free Nozzle, Dust Bag, Front Cuffs (22, 24), Battery, Charger

Capacity	Paper Dust Bag: 6.0 L Cloth Dust Bag: 5.5 L
Max Air Flow	w/ Hose complete 32-1.0: 2.2 m ³ /min w/ Hose Complete 28-1.0: 2.0 m ³ /min
Max Sealed Suction	11 kPa
Suction Power	Max / High / Normal w/ Hose 32-1.0: 95 / 50 / 25 W Max / High / Normal w/ Hose 28-1.0: 90 / 45 / 25 W
Vibration Level	Operation w/o Load: 2.5 m/s ² or less
Sound Pressure Level	70 dB(A) or less
Dimensions (L x W x H)	297x174x523 mm (11-3/4"x6-7/8"x20-5/8")
Net weight	6.1 - 6.7 kg (13.4 - 14.8 lbs.)

DVC660Z

DVC665

18V X2 (36V) LXT BL AWS HEPA Cordless Backpack Vacuum Cleaner

Cordless Backpack Vacuum Cleaner



new

- Cleaning mechanism for paper dust bag
- Auto-start Wireless System (AWS) connects to power tool with Bluetooth
- Increased suction power for improved dust collection when connected with Makita power tools
- BL motor allows 1.8 m³/min of Max air flow / 11 kPa of Max sealed suction and long run time
- Mode memory function allows to start in the same suction power when you turned it off previously



LXT BL MOTOR AWS



Floor Nozzle, Hose, Hose Band, Nozzle assembly, Telescopic pipe assembly, Bent Pipe, Switching nozzle, Free Nozzle, Dust Bag, Front Cuffs (22, 24), Battery, Charger

Capacity	Paper Dust Bag: 6.0 L Cloth Dust Bag: 5.5 L
Max Air Flow	w/ Hose Complete 28-1.5: 1.8 m ³ /min
Max Sealed Suction	11 kPa
Suction Power	High / Normal w/ Hose 28-1.5: 85 / 45 W
Vibration Level	Operation w/o Load: 2.5 m/s ² or less
Sound Pressure Level	70 dB(A) or less
Dimensions (L x W x H)	297x174x523 mm (11-3/4"x6-7/8"x20-5/8")
Net weight	6.1 - 6.7 kg (13.5 - 14.9 lbs.)

DVC665Z

DVC864L

Cordless Vacuum Cleaner

**18V X2 (36V) LXT BL AWS Brushless Cordless 8 L Dust Class L Vacuum Cleaner**

- Auto-Start Wireless System (AWS) Connects to Power Tool with Bluetooth- 18V solution for corded power demands
- Two 18V LXT Li-Ion batteries & BL motor deliver the power and performance for corded demands without leaving the 18V LXT platform
- Two 18V LXT batteries & BL motor generate 2.1 m³/min of Max air flow / 9.8 kPa of Max sealed suction / 90 W of Suction power
- Features Extreme Protection Technology (XPT) which is engineered to provide increased dust and water resistance in harsh job site conditions
- Delivers up to 40 min of run time using BL1850B

LXT **BL** **AWS** **XPT**

Floor Nozzle, Corner Nozzle, Straight Pipe, Bent Pipe, Hose (38mm-2.5m), Plastic Dust Bag, Plastic Dust Bag x10, Cloth Filter, Tool Box

Capacity	Dust : 8 L
Continuous Use (min.)	w/ BL1850B x2: 40
Max Air Flow	2.1 m ³ /min
Max Sealed Suction	9.8 kPa
Suction Power	90 W
Vibration Level	2.5 m/s ² or less
Sound Pressure Level	70 dB(A) or less
Dimensions (L x W x H)	366x334x368 mm (14-3/8"x13-1/8"x14-1/2")
Net weight	7.7 - 8.4 kg (17.1 - 18.4 lbs.)

DVC864LZ
DVC864LZX
DVC862L

Cordless Vacuum Cleaner

**18V X2 (36V) LXT BL Brushless Cordless 8 L Dust Class L Vacuum Cleaner**

- Two 18V LXT Li-Ion batteries & BL motor deliver the power and performance for corded demands without leaving the 18V LXT platform
- Two 18V LXT batteries & BL motor generate 2.1 m³/min of Max air flow / 9.8 kPa of Max sealed suction / 90 W of Suction power
- Features Extreme Protection Technology (XPT) which is engineered to provide increased dust and water resistance in harsh job site conditions
- Delivers up to 40 min of run time using BL1850B
- Approved for Dust Class L in accordance with the EU standard
- For both wet and dry vacuum cleaning

LXT **BL** **XPT**

Floor Nozzle, Corner Nozzle, Straight Pipe, Bent Pipe, Hose (38mm-2.5m), Plastic Dust Bag, Plastic Dust Bag x10, Cloth Filter, Tool Box, Battery, Charger

Capacity	Dust / Water: 8 / 6 L
Continuous Use (min.)	w/ BL1850B x2: 40
Max Air Flow	2.1 m ³ /min
Max Sealed Suction	9.8 kPa
Suction Power	90 W
Vibration Level	2.5 m/s ² or less
Sound Pressure Level	70 dB(A) or less
Dimensions (L x W x H)	366x334x368 mm (14-3/8"x13-1/8"x14-1/2")
Net weight	7.0 - 7.6 kg (15.5 - 16.8 lbs.)

DVC862LRT2
DVC862LZ
DVC155L

Cordless Vacuum Cleaner

new**18V X2 (36V) LXT BL Cordless 15 L Dust Class L Vacuum Cleaner (Wet & Dry)**

- More Powerful
- Thinner and rotatable floor nozzle for increased maneuverability
- 18V solution for corded power demands
- Two 18V LXT Li-Ion batteries & BL motor deliver the power and performance for corded demands without leaving the 18V LXT platform
- Two 18V LXT batteries & BL motor generate 2.1 m³/min of Max air flow / 11 kPa of Max sealed suction / 105 W of Suction power
- Features Extreme Protection Technology (XPT) which is engineered to provide increased dust and water resistance in harsh job site conditions

LXT **BL** **XPT**

Floor Nozzle, Long Sash Nozzle, Telescopic pipe assembly, Bent Pipe, Pipe, Hose, Plastic Dust Bag x10, Filter, Tool Box, Battery, Charger

Capacity	Dust / Water: 15 / 12 L
Continuous Use (min.)	w/ BL1850B x2: 100
Max Air Flow	2.1 m ³ /min
Max Sealed Suction	11 kPa
Suction Power	105 W
Vibration Level	2.5 m/s ² or less
Vibration K Factor	1.5 m/s ²
Sound Pressure Level	70 dB(A) or less
Noise K Factor	2.5 dB(A)
Dimensions (L x W x H)	366 x 334 x 421 mm (14-3/8 x 13-1/8 x 16-1/2")
Net weight	7.2 - 7.9 kg (15.9 - 17.4 lbs.)

DVC155LZX3**DVC150L**

Corded and Cordless Vacuum Cleaner

**Corded / 18V X2 (36V) LXT Li-Ion Cordless 15 L Dust Class L Vacuum Cleaner (Wet & Dry)**

- Two 18V LXT batteries generate 2.1 m³/min of Max air flow / 9 kPa of Max sealed suction / 70W of Suction power
- Delivers up to 65 min of run time using BL1850B
- Approved for dust class L of EC regulation
- For both wet and dry vacuum cleaning
- 15L Large dust bag capacity enables continuous cleaning work
- Large capacity of removable on-board storage for convenient storage of the hose, front cuffs, pipes, nozzles and power supply cord
- Large on-off switch allows for easy on/off switching

**LXT**

Floor Nozzle, Corner Nozzle, Straight Pipe, Bent Pipe, Hose (38mm-2.5m), Plastic Dust Bag, Plastic Dust Bag x10, Cloth Filter, Tool Box, Connection cord (country-specific), Battery, Charger

Capacity	Dust / Water: 15 / 12 L
Continuous Use (min.)	w/ BL1850B x2: 65
Max Air Flow	AC / DC: 3.6 / 2.1 m ³ /min
Max Sealed Suction	AC / DC: 24 / 9 kPa
Suction Power	AC / DC: 320 / 25 - 70 W
Vibration Level	2.5 m/s ² or less
Sound Pressure Level	75 dB(A)
Dimensions (L x W x H)	366x334x421 mm (14-3/8"x13-1/8"x16-1/2")
Net weight	8.9 - 9.6 kg (19.7 - 21.1 lbs.)

DVC150LZ**DVC151L**

Corded and Cordless Vacuum Cleaner

**Corded / 18V X2 (36V) LXT Li-Ion Cordless 15 L Dust Class L HEPA Vacuum Cleaner**

- Two 18V LXT batteries generate 2.1 m³/min of Max air flow / 9 kPa of Max sealed suction / 70W of Suction power
- Delivers up to 65 min of run time using BL1850B
- Approved for dust class L of EC regulation
- 15L Large dust bag capacity enables continuous cleaning work
- Large capacity of removable on-board storage for convenient storage of the hose, front cuffs, pipes, nozzles and power supply cord
- Large on-off switch allows for easy on/off switching

**LXT**

Floor Nozzle, Corner Nozzle, Straight Pipe, Bent Pipe, Hose (38mm-2.5m), Plastic Dust Bag, Plastic Dust Bag x10, Powder Filter, Tool Box, Connection cord (country-specific), Battery, Charger

Capacity	Dust / Water: 15 / N/A L
Continuous Use (min.)	w/ BL1850B x2: 65
Max Air Flow	AC / DC: 3.6 / 2.1 m ³ /min
Max Sealed Suction	AC / DC: 24 / 9 kPa
Suction Power	AC / DC: 320 / 25 - 70 W
Vibration Level	2.5 m/s ² or less
Sound Pressure Level	75 dB(A)
Dimensions (L x W x H)	366x334x421 mm (14-3/8"x13-1/8"x16-1/2")
Net weight	9.6 - 10.3 kg (21.2 - 22.6 lbs.)

DVC151LZ



AWS Auto-start Wireless System (DVC265 / DVC665 only)

The wireless activation function enables clean and comfortable operation. By connecting a supported tool to the cleaner, you can run the cleaner automatically along with the switch operation of the tool.

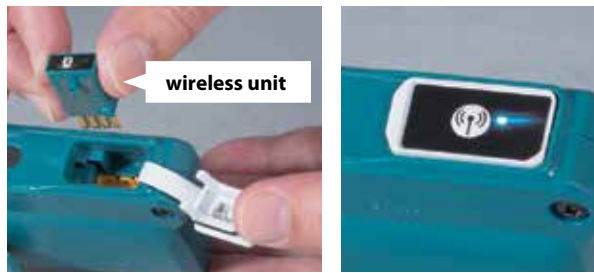

Expanding AWS Line-up



Bluetooth

AWS connects to power tool with Bluetooth

The Bluetooth® word mark and logos are registered trademarks owned by the Bluetooth SIG, Inc. and any use of such marks by Makita is under license. Other trademarks and trade names are those of their respective owners.

DVC261 18V X2 (36V) LXT HEPA BL Brushless Cordless Backpack Vacuum Cleaner

Cordless Backpack Vacuum Cleaner



- Increased suction power for improved dust collection when connected with makita power tools
- BL motor allows 2.3 m³/min of Max air flow / 11 kPa of Max sealed suction / 105 W of Suction power and long run time to go together
- Mode memory function allows to start in the same suction power when you turned it off previously
- Delivers up to 140 min of run time using BL1860B on normal setting
- Two 18V LXT Li-Ion batteries deliver the power and run time for corded demands without leaving the 18V LXT platform



Floor Nozzle, Hose, Hose Band, Nozzle assembly, Telescopic pipe assembly, Bent Pipe, Switching nozzle, Free Nozzle, Dust Bag, Front Cuffs (22, 24), Battery, Charger

Capacity	Paper Dust Bag: 2.0 L Cloth Dust Bag: 1.5 L
Max Air Flow	w/ Hose complete 32-1.0: 2.2 m ³ /min w/ Hose Complete 28-1.0: 2.0 m ³ /min w/ Hose Complete 28-1.5: 1.8 m ³ /min
Max Sealed Suction	11 kPa
Suction Power	Max / High / Normal w/ Hose 32-1.0: 95 / 50 / 25 W Max / High / Normal w/ Hose 28-1.0: 90 / 45 / 25 W Max / High / Normal w/ Hose 28-1.5: 85 / 45 / 25 W
Vibration Level	Operation w/o Load: 2.5 m/s ² or less
Sound Pressure Level	70 dB(A) or less
Dimensions (L x W x H)	297x174x523 mm (11-3/4"x6-7/8"x20-5/8")
Net weight	3.8 - 4.5 kg (8.5 - 9.9 lbs.)

DVC261Z

DVC865L 18V X2 (36V) LXT BL Cordless 8 L Dust Class L Vacuum Cleaner (Wet & Dry)

Cordless Vacuum Cleaner

new



- More Powerful
- Thinner and rotatable floor nozzle for increased maneuverability
- 18V solution for corded power demands
- Two 18V LXT Li-Ion batteries & BL motor deliver the power and performance for corded demands without leaving the 18V LXT platform
- Two 18V LXT batteries & BL motor generate 2.1 m³/min of Max air flow / 11 kPa of Max sealed suction / 105 W of Suction power
- 8L Large dust bag capacity enables continuous cleaning work



Floor Nozzle, Long Sash Nozzle, Telescopic pipe assembly, Bent Pipe, Pipe, Hose, Plastic Dust Bag x10, Filter, Tool Box, Battery, Charger

Capacity	Dust / Water: 8 / 6 L
Continuous Use (min.)	w/ BL 1860B: 100
Max Air Flow	2.1 m ³ /min
Max Sealed Suction	11 kPa
Suction Power	105 W
Vibration Level	2.5 m/s ² or less
Vibration K Factor	1.5 m/s ²
Sound Pressure Level	70 dB(A) or less
Noise K Factor	2.5 dB(A)
Dimensions (L x W x H)	366 x 334 x 368 mm (14-3/8 x 13-1/8 x 14-1/2")
Net weight	7.0 - 7.7 kg (15.4 - 17.0 lbs.)

DVC865LZX3

DHW080 Cordless High Pressure Washer

No power outlet required, No water source required.

Cars, walls, steps, etc. can be cleaned anywhere at any time.

18VX2 Cordless

Storage example



Variospray lance set



Cyclone jet nozzle set



Wash brush set



Foam nozzle set



Variable nozzle set



Pipe cleaning hose



Total amount of water flow under normal use on a full battery charge
110 L about with Variable nozzle

Run time (w/BL1850Bx2)
28 min about

Working Pressure
3.0 MPa  Low

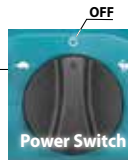

Working Pressure	Run time (w/BL1850Bx2)
5.5 MPa  High	12 min about

DHW080

Cordless High Pressure Washer

18V X2 LXT BL Cordless 8 MPa High Pressure Washer



- 5.5 MPa Regular Pressure
- Max permissible pressure 8 MPa as high as AC model has been achieved by employing high power brushless DC motor and Makita-built pump
- Stepless pressure adjustment close at hand
- Jet pressure can be steplessly adjusted close at hand by turning the nozzle of the variespray lance
- Jet pressure can be changed to low pressure mode, ideal for gently washing door and window screens, air conditioner outdoor units and car surface



Trigger Gun, High Pressure Hose 5 m, Suction Hose, Cleaner Pin, Storage Box, Variable nozzle, Connector, One touch joint, Battery, Charger

Max Permissible Pressure	8.0 MPa (N/A bars)
Regular Pressure	High / Low: 5.5 / 3.0 MPa (N/A / N/A bars)
Max Water Flow	380 L/h (6.3 L/min)
Regular Flow	High / Low: 330 / 240 L/h (5.5 / 4.0 L/min)
High Pressure Hose Length	5 m (16 ft.)
Vibration Level	2.5 m/s ² or less
Sound Pressure Level	70.9 dB(A)
Dimensions (L x W x H)	438x218x269 mm (17-1/4"x8-5/8"x10-5/8")
Net weight	7.1 - 7.7 kg (15.6 - 17.0 lbs.)

DHW080PT2
DHW080ZK



Free from cord



Supplying water from a tank/reservoir

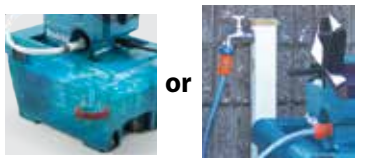

Under body spray lance set



Rotating brush set



time <small>(350Bx2)</small>	Total amount of water flow under normal use on a full battery charge
5 about min	70 about L with Variable nozzle



Multi function storage case

Suction tank function + storability

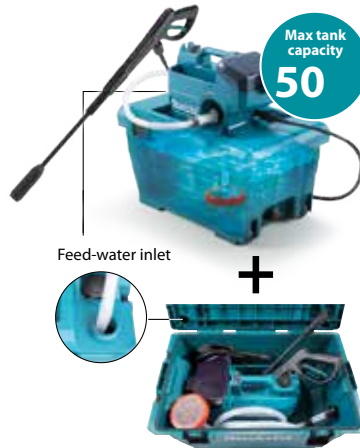

Easy to transport

Transportable with the machine body stored in the tank.



*When carrying the storage box by the handle, water may spill out if there is plenty of water inside.

*When carrying this model located on the lid of the storage box by the handle, the model may drop off from the storage box.

MAKPAC (Option)

MAKPAC case can be installed on the lid.



No need to connect to outlet or tap

Cordless Chain Saw

DUC355 350 mm (14") Captive nuts type
 DUC353 350 mm (14") Tool-less chain adjustment type

High performance

Variable speed control by trigger



High operating efficiency

Outer Rotor BL Motor provides high operating efficiency



Extreme Protection Technology

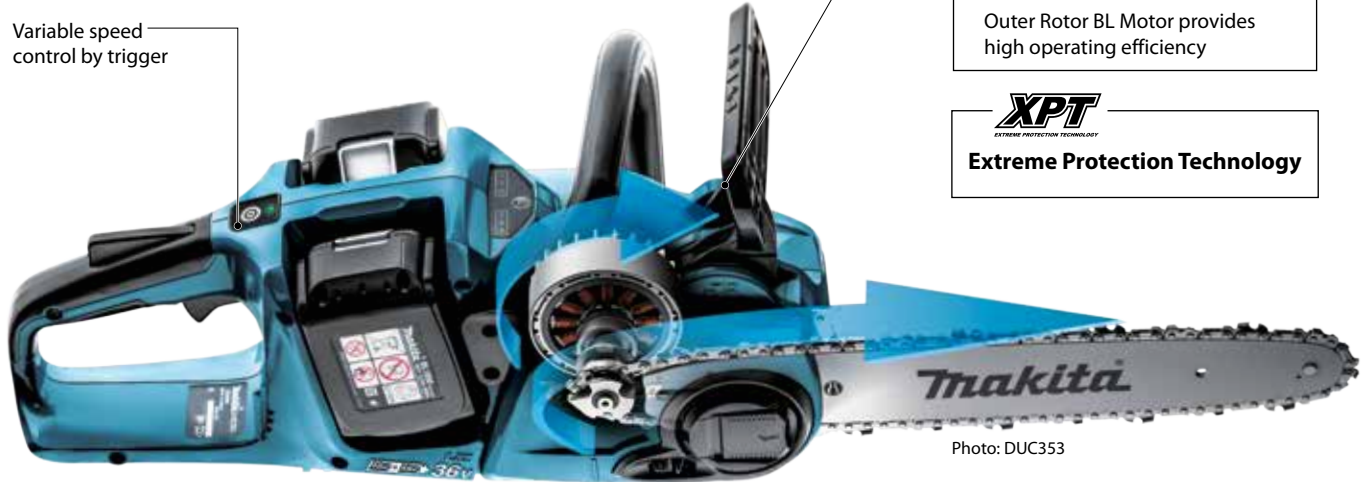

Photo: DUC353

DUC355Z

DUC353Z

DUC355 / DUC353 18V X2 (36V) LXT BL Brushless Cordless Chain Saw

	DUC353	DUC355
Guide Bar Length	350 mm (14")	350 mm (14")
Cutting Length	330 mm (13")	330 mm (13")
Chain Pitch	3/8"	3/8"
Chain Gauge	1.1 / 1.3 mm (0.043" / 0.050")	1.1 mm (0.043")
Chain Speed	0 - 20 m/s (0 - 1,200 m/min) (0 - 3,940 FPM)	0 - 20 m/s (0 - 1,200 m/min) (0 - 3,940 FPM)
Chain Oil Tank Volume	200 mL	200 mL
Sound Pressure Level	87.7 dB(A)	87.7 dB(A)
Sound Power Level	100.4 dB(A)	100.4 dB(A)
Vibration Level	Cutting Wood: 5.3 m/s ²	Cutting Wood: 5.3 m/s ²
Dimensions (L x W x H)	762x215x235 mm (30"x8-1/2"x9-1/4")	762x211x235 mm (30"x8-5/16"x9-1/4")
Net weight	4.7 - 5.3 kg (10.4 - 11.7 lbs.)	4.7 - 5.4 kg (10.4 - 11.8 lbs.)



DUC353 : Saw Chain, Guide Bar, Guide Bar Cover, Oil supply (country-specific), Battery, Charger
 DUC355 : Saw Chain, Guide Bar, Guide Bar Cover, Oil supply (country-specific), Round File (country-specific), File (country-specific), Box Wrench, Battery, Charger

DUC356 18V X2 (36V) LXT BL Brushless Cordless 35 cm (14") Chain Saw

Cordless Chain Saw



- Outer Rotor BL motor direct-drive system delivers 0-20 m/s (0-1,200 m/min) (0-3,940 FPM) chain speed for fast cutting, equivalent to 30 mL class engine chain saw
- Powered by two 18V LXT Li-Ion batteries
- Two 18V LXT Li-Ion batteries deliver power and performance without leaving the 18V LXT platform
- Low noise level and zero emissions for operator comfort
- "Tool-less" chain adjustment for convenient operation and maintenance



Saw Chain, Guide Bar, Guide Bar Cover, Spike Bumper, Battery, Charger

Guide Bar Length	350 mm (14")
Cutting Length	350 mm (14")
Chain Pitch	3/8"
Chain Gauge	1.3 mm (0.05")
Chain Speed	0 - 20 m/s (0 - 1,200 m/min) (0 - 3,940 FPM)
Chain Oil Tank Volume	200 mL (6.8 US oz)
Sound Pressure Level	89 dB(A)
Sound Power Level	103 dB(A)
Vibration Level	Cutting Wood: 3.2 m/s ²
Dimensions (L x W x H)	270-651x205x232 mm (10-5/8"-25-5/8"x8-1/8"x9-1/8")
Net weight	4.6 - 5.1 kg (10.1 - 11.1 lbs.)

DUC356PT2
 DUC356Z



Cordless Multi Function Power Head

DUX60



Multi-function system

consisting of power head and versatile optional attachments are ideal for a wide range of applications

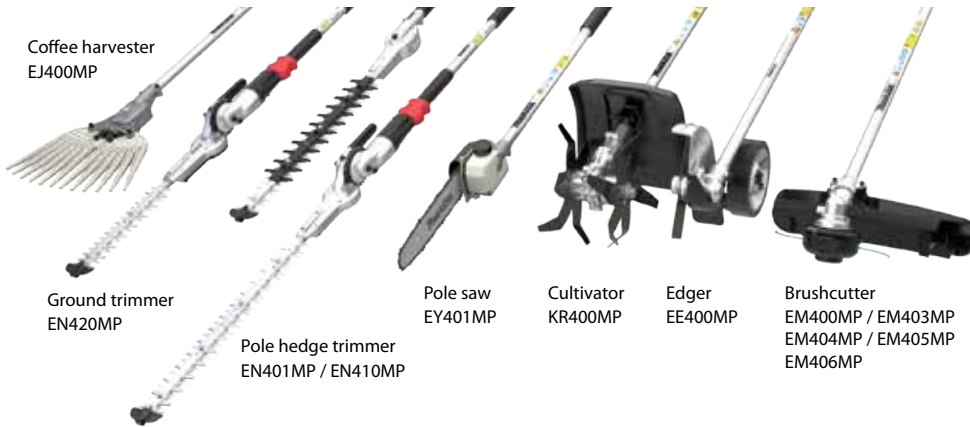

Coffee harvester
EJ400MP

Ground trimmer
EN420MP

Pole hedge trimmer
EN401MP / EN410MP

Pole saw
EY401MP

Cultivator
KR400MP

Edger
EE400MP

Brushcutter
EM400MP / EM403MP
EM404MP / EM405MP
EM406MP



Shaft extension attachment
LE400MP

Length: 1,080mm (42-1/2")

For Pole saw, Pole hedge trimmer and Coffee harvester



High operating efficiency

BL Motor provides high operating efficiency



Active Feedback sensing Technology

Shuts down the tool to protect the user, if the rotation speed suddenly slows down.



Reverse switch for easy removal of grass clippings from the cutting tool

Grass clippings can be removed by slow reverse rotation of the cutting tool (automatically stops in 3 seconds) by pressing Touch button switch and pulling Trigger switch.



DUX60 18V X2 LXT BL AFT Cordless Multi Function Power Head

Cordless Multi Function Power Head

No Load Speed (RPM)	High: 0 - 9,700 Medium: 0 - 8,200 Low: 0 - 5,700
Dimensions (L x W x H)	1,011x320x216 mm (39-3/4"x12-5/8"x8-1/2")
Net weight	4.1 - 8.7 kg (8.9 - 19.2 lbs)



18V DUX60ZM3
DUX60Z

Harness, Safety Goggles, Hex Wrench, Accessory Bag, Tool bag (for spec with Brushcutter attachment only), Carbide-Tipped Saw Blade (for spec with EM402MP only), Box Wrench (for spec with EM402MP / EM403MP / EM404MP only), Metal blade fixing tool (Clamp washer, Nut, Cup) (for spec with EM402MP/EM403MP/EM404MP), Nylon Cutting Head (for spec with EM403MP / EM404MP / EM405MP / EM406MP only), Without Battery



Extreme Protection Technology





Battery Powered Grass Trimmer

UR101C / UR201C / UR202C + PDC01

"Simple" Portable Power Supply Unit powered by multiple LXT batteries

Intermediate connector

If the cord of the tool adapter is loaded with a certain weight or over, the intermediate connector between the tool and the tool adapter is automatically disconnected.



UR201C

PDC01

Powered by up to four 18V LXT batteries



Backpack harness

Also can be used as a stationary power pack by detaching the backpack harness

Fuel gauge for each battery

indicates the battery status by two green lamps.



Main power switch

with auto-off function

UR101C / UR201C

Battery Powered Grass Trimmer

new



BL ADT AFT Battery Powered 3-Speed Grass Trimmer

- High power 1 kW
- Excellent in continuous work
- 43 cm cutting width with nylon cutting head for user convenience
- Automatic Torque Drive Technology (ADT) adjusts speed and torque during operation for optimum performance
- Active Feedback Sensing Technology (AFT) turns the motor off if blade rotation is suddenly forced to stop

BL MOTOR ADT AFT XPT



Safety Goggles, Metal Blade / Nylon Cutting Head / Plastic Blade (country-specific), Blade cover (for the product with metal blade), Accessory Bag, Hex Wrench, Box Driver, Shoulder Belt, Battery, Charger

Cutting Width	Metal Blade: 255 mm (10") (UR101C / UR201C Only) Trimmer Head: 430 mm (17") Plastic Blade: 255 mm (10")
No Load Speed (RPM)	UR101C, UR201C: High / Med / Low: 0-7,000 / 5,500 / 4,600
Spindle Size	M10 x 1.25 LH
Dimensions (L x W x H)	UR101C: 1,760x628x550 mm (69-1/4"x24-3/4"x21-5/8") UR201C: 1,760x400x269 mm (69-1/4"x15-3/4"x10-5/8") (69"x8-15/16"x11-7/8")
Net weight	UR101C: 5.4 kg (11.8 lbs.) UR201C: 4.9 kg (10.7 lbs.)

UR101CZ

UR201CZ

PDC01

Portable Power Pack

new



18V / 18V X2 (36V) LXT Li-Ion Portable Power Pack

- The user of 18V LXT batteries can get longer run time at less cost
- Compatible with two LXT platforms; 18V LXT and 18V x2 LXT
- Tool adapter with pivoting cord; designed for use with a variety of tools; increases the maneuverability of a connected tool
- Height-adjustable waist belt; the position of the waist belt can be adjusted for personal fit and comfort
- Battery cover protects batteries inside the battery box from water and dust
- Fuel gauge for each battery indicates the battery status by two green lamps
- Main power switch with auto-off function
- Intermediate connector; if the cord of the tool adapter is loaded with a certain weight or over, the intermediate connector between the tool and the tool adapter is automatically disconnected

LXT

Capacity	24 / 12 Ah
Energy Capacity	432 Wh
Dimensions (L x W x H)	400x195x132 mm (15-3/4"x7-5/8"x5-3/16")
Net weight	1.7 kg (5.6 lbs.)

Harness, Adapter

PDC01

Cordless Lawn Mower Series

DLM530, DLM532, DLM533 530 mm (21") / DLM462, DLM460 460 mm (18") / DLM432 430 mm (17") / DLM382 380 mm (15")

ZERO EMISSION

Aluminum Deck — **DLM533**

Steel Deck — **DLM532 / DLM530 / DLM462**



Self-Propelled
(DLM533 / DLM532 / DLM462 only)



BL
MOTOR

IPX4 (water resistant)



Built-in ball bearing on axles for added durability



photo: DLM533

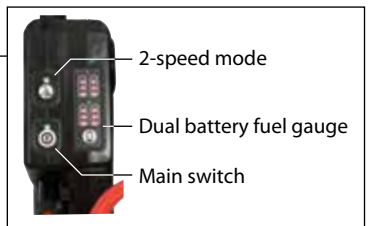

Grass level indicator
(DLM533 / DLM532 / DLM530 / DLM462)



empty

full

4 battery slots
(DLM533 / DLM532 / DLM530 / DLM462)



Steel Deck
DLM460

BL
MOTOR



Plastic Deck
DLM382
DLM432



Recommended mowing area

DLM533 / DLM532 / DLM530

DLM462

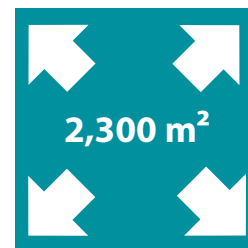

BL1860B x4

BL1860B x4

DLM460

DLM432

DLM382



BL1860B x2

BL1860B x2

BL1860B x2

	Deck	Self-Propelled	BL MOTOR	Battery slots	Cutting	Collecting	Mulching	Rear discharge	Side discharge
DLM533	Aluminum	✓	✓	4	✓	✓	✓	✓	
DLM532	Steel	✓	✓	4	✓	✓	✓		✓
DLM530	Steel		✓	4	✓	✓	✓		✓
DLM462	Steel	✓	✓	4	✓	✓	✓		
DLM460	Steel		✓	2	✓	✓	✓		
DLM432	Plastics			2	✓	✓	✓*		
DLM382	Plastics			2	✓	✓	✓*		

* Optional accessory

DLM533 18V X2 LXT BL Brushless Cordless 53 cm (21") Self-Propelled Lawn Mower

Cordless Lawn Mower

**new**

- Aluminum deck for less rusting
- Rear discharge
- Increased handle durability
- Robust protection bumper for increased durability
- Long run time by having 4 battery slots
- Soft no load automatically reduces the motor speed according to load condition for low noise and longer run time

LXI **BL** MOTOR **XPT**

Blade, Mulch plug, Socket Wrench, Rod, Battery, Charger

Cutting Width	534 mm (21")
Cutting Height	20 - 100 mm (13/16" - 3-15/16")
No Load Speed (RPM)	2,300 - 2,800
Propelling speed	2.5 - 5.0 km/h
Dimensions (L x W x H)	1,655 - 1,740 x 590 x 990 - 1,100 mm (65 - 68-1/2 x 23-1/4 x 39 - 43-1/4")
Net weight	42.8 - 46.7 kg (94.4 - 103 lbs.)

DLM533PT4
DLM533Z
DLM462 / DLM530 / DLM532 18V X2 LXT BL Brushless Cordless Self-Propelled Lawn Mower (DLM462 / DLM532 only)

Cordless Lawn Mower

**new**

- Wide and robust steel cutting deck for increased durability
- Increased handle durability
- Side discharge (DLM530 / DLM532 only)
- Long run time by having 4 battery slots
- Soft no load automatically reduces the motor speed according to load condition for low noise and longer run time
- Quiet mode provides rotation speed (2,500 RPM) by constant speed control

LXI **BL** MOTOR **XPT**

Blade, Mulch plug, Side Discharge Mouth (DLM530 / DLM532 only), Socket Wrench, Rod, Battery, Charger

Cutting Width	DLM462: 460 mm (18) DLM530 / DLM532: 534 mm (21")
Cutting Height	20 - 100 mm (13/16" - 3-15/16")
No Load Speed (RPM)	2,500 - 3,300
Propelling speed	2.5 - 5.0 km/h (DLM462 / DLM532)
Dimensions (L x W x H)	DLM462: 1,610-1,690x535x980-1,190 mm (63-1/2"-66-1/2"x21"x38-1/2"-46-3/4") DLM530 / DLM532: 1,630-1,715x590x990-1,190 mm (64"-67-1/2"x23-1/4"x39"-46-3/4")
Net weight	DLM462: 35.3 - 39.0 kg (77.8 - 86.0 lbs.) DLM530: 35.5 - 39.3 kg (78.3 - 86.6 lbs.) DLM532: 39.1 - 42.9 kg (86.2 - 94.5 lbs.)

DLM462PT4
DLM462Z
DLM530PT4
DLM530Z
DLM532PT4
DLM532Z
DLM460 18V X2 (36V) LXT BL Brushless Cordless 46 cm (18") 3-in-1 Lawn Mower

Cordless Lawn Mower



- 800 m² large mowing area
- Soft no load automatically reduces the motor speed according to load condition for low noise
- Quiet mode provides rotation speed (2,500 RPM) by constant speed control
- Wide 46 cm (18") robust steel cutting deck for increased durability
- IPX4 water resistant for use in bad weather

LXI **BL** MOTOR **XPT**

Blade, Socket Wrench, Battery, Charger

Cutting Width	460 mm (18")
Cutting Height	20 - 75 mm (13/16" - 2-5/16")
No Load Speed (RPM)	2,500 - 3,300
Sound Pressure Level	79 dB(A)
Sound Power Level	91 dB(A)
Vibration Level	2.5 m/s ² or less
Dimensions (L x W x H)	1,319-1,518x532x879-1,138 mm (52"-59-3/4"x21"x34-1/2"-44-3/4")
Net weight	25.3 - 27.6 kg (55.8 - 60.8 lbs.)

DLM460PT2
DLM460Z
DLM382 / DLM432 18V X2 (36V) LXT Li-Ion Cordless 38 cm (15") / 43 cm (17") 2-in-1 LawnMower

Cordless Lawn Mower

**new**

- Mulching (with optional accessory)
- Two 18V LXT Li-Ion batteries deliver the power and run time for corded demands without leaving the 18V LXT platform
- Grass box with grass level indicator
- XPT (eXtreme Protection Technology) dust and drip-proof performance is enhanced for use in bad weather

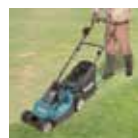
LXI **XPT**

Blade, Wrench, Battery, Charger

Cutting Width	DLM382: 380 mm (15") DLM432: 430 mm (17")
Cutting Height	20 - 75 mm (13/16" - 2-5/16")
No Load Speed (RPM)	DLM382: 3,700 / DLM432: 3,600
Dimensions (L x W x H)	DLM382: 1,380-1,410x450x985-1,005 mm (54-1/4"-55-1/2"x17-3/4"x38-3/4"-39-1/2") DLM432: 1,435-1,490x460x1,005-1,045 mm (56-1/2"-58-3/4"x18-1/8"x39-1/2"-41-1/4")
Net weight	DLM382: 16.2 - 16.9 kg (35.7 - 37.3 lbs.) DLM432: 16.8 - 17.5 kg (36.6 - 38.6 lbs.)

DLM382PT2
DLM382Z

Cordless Grass Trimmer

DUR369A / DUR368A / DUR368L

new

High power as 25mL engine tool

BL MOTOR Outer Rotor BL Motor provides high operating efficiency



Offset bike handle

The vertical center line of the handle bar always stays aligned with that of user, enabling user to work with less fatigue even in long continuous operation.

- allowing for a wider swing.



Reverse switch

Reverse switch for clearing entangled weeds and grass from cutting head



Compatible with 3-blade plastic blade

The blade is of swing back type and protects the user and machine if it hits against hard or stationary objects.

Automatic torque Drive Technology

ADT

Automatically changes the cutting speed according to grass density.



Operation mode can be selected to suit the type of blade.

Plastic blade mode

Nylon cord mode

Work amount

on a single full battery charge

about **290 m²** with BL1850B x2

Work amount depends on the condition of battery, the type of grass, season, etc.

automatically changes the cutting speed according to load conditions for an optimum operation:

- On light duty: high-speed rotation mode
- On heavy duty: high torque mode

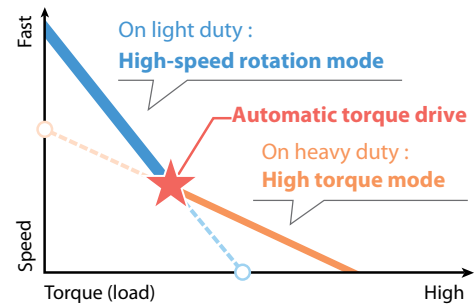

DUR369A

18V X2 (36V) LXT BL ADT AFT Cordless 3-Speed Grass Trimmer

Cordless Grass Trimmer

new

- High power 1.0 kW
- Excellent in continuous work
- 43 cm cutting width with nylon cutting head for user convenience
- Automatic Torque Drive Technology (ADT) adjusts speed and torque during operation for optimum performance
- Active Feedback Sensing Technology (AFT) turns the motor off if blade rotation is suddenly forced to stop



LXT BL MOTOR ADT AFT XPT



Safety Goggles, Metal Blade / Nylon Cutting Head / Plastic Blade (country-specific), Blade cover (for the product with metal blade), Accessory Bag, Hex Wrench, Shoulder Belt, Battery, Charger

Cutting Width	Metal Blade: 255 mm (10") Trimmer Head: 430 mm (17") Plastic Blade: 305 mm (12")
No Load Speed (RPM)	High / Med / Low: 3,300 / 7,000 / 5,500 / 4,600
Spindle Size	M10 x 1.25 LH
Dimensions (L x W x H)	1,846x628x530 mm (72-1/2"x24-3/4"x20-7/8")
Net weight	6.0 - 6.6 kg (13.2 - 14.6 lbs.)

DUR369APT2
DUR369AZ

DUR368A / DUR368L

18V X2 (36V) LXT BL ADT AFT Cordless 3-Speed Grass Trimmer

Cordless Grass Trimmer

new

- Automatic Torque Drive Technology (ADT) adjusts speed and torque during operation for optimum performance
- Active Feedback Sensing Technology (AFT) turns the motor off if blade rotation is suddenly forced to stop
- Makita-built Outer Rotor BL Brushless Motor direct-drive system provides high power and increased torque
- Constant speed control minimizes reduction in rotation speed under load



LXT BL MOTOR ADT AFT XPT



Safety Goggles, Metal Blade / Nylon Cutting Head / Plastic Blade (country-specific), Blade cover (for the product with metal blade), Accessory Bag, Hex Wrench, Box Driver, Shoulder Belt, Battery, Charger

Cutting Width	Metal Blade: 255 mm (10") Trimmer Head: 350 mm (13-3/4") Plastic Blade: 255 mm (10")
No Load Speed (RPM)	High / Med / Low: 6,500 / 5,300 / 3,500
Spindle Size	M10 x 1.25 LH
Sound Pressure Level	4-Tooth Blade: 74.7 dB(A)
Sound Power Level	4-Tooth Blade: 89.2 dB(A)
Sound Pressure Level	Nylon Cutting Head: 76.4 dB(A)
Sound Power Level	Nylon Cutting Head: 89 dB(A)
Vibration Level	Left / Right: 2.5 / 2.5 m/s ² or less
Dimensions (L x W x H)	DUR368A: 1,758x615x442 mm (69-1/4"x24-1/4"x17-3/8") DUR368L: 1,758x362x231 mm (69-1/4"x14-1/4"x9-1/8")
Net weight	DUR368A: 4.1 - 4.7 kg (9.0 - 10.5 lbs.) DUR368L: 3.9 - 4.5 kg (8.6 - 10.0 lbs.)

DUR368APT2
DUR368LPT2

DUR368AZ
DUR368LZ

18V + 18V → 36V

Li-Ion Ah 6.0 5.0 4.0 3.0 2.0 1.5

Battery & charger time reference chart P.20

DUP361

18V X2 (36V) LXT Li-Ion Battery Powered Pruning Shears

Battery Powered Pruning Shears



- 18V solution for corded power demands
- Two 18V LXT Li-Ion batteries deliver the power and performance for corded demands without leaving the 18V LXT platform
- High cutting performance
- Smooth cutting similar to that of a hand pruner
- Extra sharp, Made-in-Japan forged blade
- One touch blade opening adjustment
- Ergonomically designed handle with soft grip



LXT XPT

Oil supply (country-specific), Wrench set, Diamond File, Cord Holder, Holster, Harness, Arm Band, Tool bag, Battery, Charger, Shear Blade

Capacity	Max cutting : 33 mm
	Max blade opening: 54 mm
Sound Pressure Level	70 dB(A) or less
Vibration Level	2.5 m/s ² or less
Dimensions (L x W x H)	305x43x106 mm (12"x1-11/16"x4-3/16")
Net weight	0.8 kg (1.8 lbs.)

DUP361Z

DUP362

18V X2 (36V) LXT Li-Ion Battery Powered Pruning Shears

Battery Powered Pruning Shears



- Higher Torque for Increased Cutting Performance compared with DUP361
- 18V solution for corded power demands
- Two 18V LXT Li-Ion batteries deliver the power and performance for corded demands without leaving the 18V LXT platform
- Smooth cutting similar to that of a hand pruner
- Extra sharp, made-in-Japan forged blade
- One touch blade opening adjustment



LXT XPT

Oil supply (country-specific), Wrench set, Diamond File, Cord Holder, Holster, Harness, Arm Band, Tool Bag, Battery, Charger, Shear Blade

Capacity	Max cutting : 33 mm (1-5/16")
	Max blade opening: 54 mm
Sound Pressure Level	70 dB(A) or less
Vibration Level	2.5 m/s ² or less
Dimensions (L x W x H)	305x43x106 mm (12"x1-11/16"x4-3/16")
Net weight	0.77 - 0.82 kg (1.7 - 1.8 lbs.)

DUP362PT2
DUP362Z

Cordless Blower

DUB363

new

2 in 1 (Blower & Vacuum cleaner)

3-stage telescopic long nozzle with an adjustment range of 100mm (4")



100mm



Variable trigger switch + Cruise control lever



DUB363 is equipped with Interlock switch that can detect whether Pipe and Fan cover are attached correctly or not. The machine does not work when they are not installed properly.



DUB363

18V X2 (36V) LXT BL Brushless Cordless Variable Speed Blower

Cordless Blower

new

- Blower / vacuum cleaner
- Powerful: Amazing 65 m/s operation
- Variable trigger switch + Cruise control lever
- Mulching shredder
- Low noise



LXT BL MOTOR XPT



Vacuum kit, Flat Nozzle, Hex Wrench, Battery, Charger

Max Air Volume	13.4 m ³ /min (473 CFM)
Max Air Velocity	65 m/s
No Load Speed (RPM)	0 - 7,850
Dimensions (L x W x H)	w/ 3-Stage Telescopic Long Nozzle: 737/786/836x200x415 mm (7-7/16"/31"/33"x7-7/8"x16-3/8")
Net weight	4.3 - 6.6 kg (9.4 - 14.6 lbs.)

DUB363PT2V
DUB363ZV

DUB362

18V X2 (36V) LXT BL Brushless Cordless Variable 6-Speed Blower

Cordless Blower



- Our most powerful cordless blower yet: Amazing 54 m/s and 13.4 m³/min operation
- Delivers up to 28 minutes of run time at 15,800 RPM using two 18V LXT 5.0Ah batteries
- 6-Stage air velocity/volume selection dial with variable speed control trigger
- 3-Stage telescopic long nozzle with adjustment range of 100 mm for user convenience
- Compact and lightweight for single handed operation



LXT BL MOTOR XPT



Shoulder Belt, Nozzle

Max Air Volume	13.4 m ³ /min (473 CFM)
Max Air Velocity	54 m/s (120 MPH)
No Load Speed (RPM)	11,400 - 21,500
Sound Pressure Level	79.1 dB(A)
Sound Power Level	93.5 dB(A)
Vibration Level	2.5 m/s ² or less
Dimensions (L x W x H)	830/880/930x205x295 mm
Net weight	(32-3/4"/34-3/4"/36-5/8"x8-1/8"x11-5/8") 3.5 - 4.2 kg (7.7 - 9.3 lbs.)

DUB362PT4X
DUB362Z

DUB361

18V X2 (36V) LXT Li-Ion Cordless 2-Speed Blower

Cordless Blower



- Delivers up to 73 minutes of run time using two 4.0Ah 18V LXT batteries on low speed setting
- Makita-built motor produces a maximum air velocity of 93 m/s
- 2-Speed (10,000 & 17,000 RPM) design for optimum speed control
- Compact and lightweight for single handed operation
- Push button air volume selection (High / Low settings)



LXT XPT



Shoulder Belt, Nozzle

Max Air Volume	High: 4.4 m ³ /min (155 CFM) Low: 2.6 m ³ /min (92 CFM)
Max Air Velocity	High: 93 m/s (208 MPH) Low: 57 m/s (128 MPH)
No Load Speed (RPM)	High: 17,000 Low: 10,000
Sound Pressure Level	82.3 dB(A)
Sound Power Level	94.7 dB(A)
Vibration Level	2.5 m/s ² or less
Dimensions (L x W x H)	905x141x194 mm (35-5/8"x5-5/8"x7-5/8")
Net weight	3.1 - 3.2 kg (6.8 - 7.1 lbs.)

DUB361Z

DUH651

18V X2 (36V) LXT Li-Ion Cordless Hedge Trimmer

Cordless Hedge Trimmer



- 18V solution for corded power demands
- Two 18V LXT Li-Ion batteries deliver the power and performance for corded demands without leaving the 18V LXT platform
- Makita-built motor delivers 3,600 SPM for faster cutting
- 6 speed dial (2,000 - 3,600 SPM) allows the user to match the speed to the application



LXT XPT



Blade Cover

Blade Length	650 mm (25-1/2")
Strokes Per Minute (SPM)	2,000 - 3,600
Tooth Spacing	36 mm (1-7/16")
Sound Pressure Level	82 dB(A)
Sound Power Level	91.1 dB(A)
Vibration Level	2.5 m/s ² or less
Dimensions (L x W x H)	1,135x225x200 mm (44-3/4"x8-7/8"x7-7/8")
Net weight	4.7 - 5.5 kg (10.3 - 12.0 lbs.)

DUH651Z



DDF458

18V LXT Li-Ion Cordless 13 mm (1/2") 84 N-m (750 in.lbs.) Driver Drill

440

Cordless Driver Drill



- Delivers 91 N-m (810 in.lbs.) of Max Torque
- Mechanical 2-speed transmission (0 - 400 & 0 - 2,000 RPM) covers a wide range of drilling and fastening applications
- Compact design at only 225 mm (8-7/8") long and lightweight for reduced operator fatigue
- Extreme Protection Technology (XPT) is engineered for improved dust and water resistance for operation in harsh conditions
- All metal gears and aluminum gear housing for maximum jobsite durability



LXT XPT



(+)(-) Bit, Side Grip

Capacity	Steel: 13 mm (1/2") Wood: 76 mm (3")
No Load Speed (RPM)	High: 0-2,000 Low: 0-400
Max Fastening Torque	Hard / Soft: 91 / 58 N-m
Max lock torque	84 N-m (750 in.lbs.)
Dimensions (L x W x H)	225x79x259 mm (8-7/8"x3-1/8"x10-1/4")
Net weight	2.1 - 2.5 kg (4.7 - 5.4 lbs.)

DDF458RFE

DDF484

18V LXT BL Brushless Cordless 13 mm (1/2") 60 N-m (530 in.lbs.) Driver Drill

Cordless Driver Drill



- Delivers 25% more drilling, driving and fastening speed than previous model
- Aluminum gear housing creates an impression of rigidity and luxuriousness
- Compact and ergonomic design at only 172 mm (6-3/4") long
- Variable 2-speed (0-500 & 0-2,000 RPM) for a wide range of drilling and fastening applications
- Built-in twin LED lights with pre-glow and afterglow functions illuminate the work area



LXT BL MOTOR XPT



(+)(-) Bit, Belt Clip

Capacity	Steel / Wood: 13 / 38 mm (1/2" / 1-1/2")
Chuck capacity	1.5 - 13 mm (1/16 - 1/2")
No Load Speed (RPM)	High / Low: 0 - 2,000 / 0 - 500
Max Fastening Torque	Hard / Soft: 54 / 30 N-m (480 / 270 in.lbs.)
Max lock torque	60 N-m (530 in.lbs.)
Vibration Level	Drilling Into Metal: 2.5 m/s ² or less
Sound Pressure Level	76 dB(A)
Dimensions (L x W x H)	172x79x261 mm (6-3/4"x3-1/8"x10-1/4")
Net weight	1.5 - 1.8 kg (3.3 - 4.0 lbs.)

DDF484RFE
DDF484Z

DDF482

18V LXT Li-Ion Cordless 13 mm (1/2") 54 N-m (480 in.lbs.) Driver Drill

440

Cordless Driver Drill



- High speed model with compact and lightweight design
- Compact overall length: 185 mm for increased maneuverability
- Lightweight for reduced operator fatigue
- Higher speed of 1,900 RPM (High) and 600 RPM (Low)
- Variable 2-speed transmission (0-600 & 0-1,900 RPM) for a wide range of drilling and fastening applications



LXT XPT



Belt Clip, (+)(-) Bit

Capacity	Steel / Wood: 13 / 38 mm (1/2" / 1-1/2")
Chuck capacity	1.5 - 13 mm (1/16 - 1/2")
No Load Speed (RPM)	High / Low: 0 - 1,900 / 0 - 600
Max Fastening Torque	Hard / Soft: 62 / 36 N-m (550 / 320 in.lbs.)
Max lock torque	54 N-m (480 in.lbs.)
Vibration Level	Drilling Into Metal: 2.5 m/s ² or less
Sound Pressure Level	75 dB(A)
Dimensions (L x W x H)	185x79x249 mm (7-1/4"x3-1/8"x9-3/4")
Net weight	1.5 - 1.8 kg (3.2 - 4 lbs.)

DDF482RME
DDF482RFX1

DDF482RFE
DDF482Z

DDF485

18V LXT BL Brushless Cordless 13 mm (1/2") 50 N-m (440 in.lbs.) Driver Drill

Cordless Driver Drill



- Max 1,900 RPM & 50 N-m (440 in.lbs.) for Increased Efficiency
- Compact design for reduced operator fatigue
- Dual LED lights with preglow and afterglow functions illuminate the work area
- Ergonomically designed grip for comfortable handling
- Variable 2-speed (0-500 & 0-1,900 RPM) for a wide range of drilling and fastening applications



LXT BL MOTOR XPT



Belt Clip, (+)(-) Bit

Capacity	Steel / Wood: 13 / 38 mm (1/2" / 1-1/2")
Chuck capacity	1.5 - 13 mm (1/16 - 1/2")
No Load Speed (RPM)	High / Low: 0 - 1,900 / 0 - 500
Max Fastening Torque	Hard / Soft: 57 / 27 N-m (440 / 240 in.lbs.)
Max lock torque	50 N-m (440 in.lbs.)
Vibration Level	Drilling Into Metal: 2.5 m/s ² or less
Sound Pressure Level	74 dB(A)
Dimensions (L x W x H)	w/ BL1815N / BL1820B: 169x79x237 mm (6-5/8"x3-1/8"x9-3/8") w/ BL1830B / BL1840B / BL1850B / BL1860B: 169x79x255 mm (7-1/8"x3-1/8"x10")
Net weight	1.4 - 1.7 kg (3.1 - 3.8 lbs.)

DDF485RFE
DDF485Z

DDF453

18V LXT Li-Ion Cordless 13 mm (1/2") 38 N-m (340 in.lbs.) Driver Drill

Cordless Driver Drill



- Compact and lightweight design
- Variable 2-speed design (0-400 & 0-1,300 RPM) covers a wide range of drilling, driving and hammer applications
- All metal gear construction ensures high transmission durability
- Single sleeve keyless chuck enables easy bit installation/removal with one hand
- Ergonomically designed rubberized soft grip provides more control and comfort



LXT



(+)(-) Bit

Capacity	Steel: 13 mm (1/2") Wood: 36 mm (1-7/16")
No Load Speed (RPM)	High: 0-1,300 Low: 0-400
Max Fastening Torque	Hard / Soft: 42 / 27 N-m
Max lock torque	38 N-m (340 in.lbs.)
Dimensions (L x W x H)	222x79x244 mm (8-3/4"x3-1/8"x9-5/8")
Net weight	1.7 - 2 kg (3.7 - 4.4 lbs.)

DDF453SFE
DDF453SFE3
DDF453SFX1

DDF453SFX7
DDF453RFX1
DDF453SVE

DDF483

18V LXT BL Brushless Cordless 13 mm (1/2") 40 N-m (350 in.lbs.) Driver Drill

Cordless Driver Drill



- Ultra-compact and ergonomic design at only 162 mm long and lightweight for reduced operator fatigue
- BL motor eliminates carbon brushes, enabling the BL motor to run cooler and more efficiently for longer life
- Variable 2-speed (0-500 & 0-1,700 RPM) for a wide range of drilling and fastening applications
- BL motor is electronically controlled to optimize battery energy use for up to 50% longer run time per charge
- BL motor efficiently uses energy to match torque and RPM to the changing demands of the application



LXT BL MOTOR XPT



Belt Clip, (+)(-) Bit

Capacity	Steel / Wood: 13 / 36 mm (1/2" / 1-7/16")
Chuck capacity	1.5 - 13 mm (1/16 - 1/2")
No Load Speed (RPM)	High / Low: 0 - 1,700 / 0 - 500
Max Fastening Torque	Hard / Soft: 40 / 23 N-m (350 / 210 in.lbs.)
Max lock torque	40 N-m (350 in.lbs.)
Vibration Level	Drilling Into Metal: 2.5 m/s ² or less
Sound Pressure Level	77 dB(A)
Dimensions (L x W x H)	162x79x247 mm (6-3/8"x3-1/8"x9-3/4")
Net weight	1.2 - 1.6 kg (2.7 - 3.4 lbs.)

DDF483RTE
DDDF483RFE
DDF483Z

DDF083

18V LXT BL Brushless Cordless 6.35 mm (1/4") Hex 40 N-m (350 in.lbs.) Driver Drill

Cordless Driver Drill



- Ultra-compact and ergonomic design at only 124 mm long and lightweight for reduced operator fatigue
- BL motor eliminates carbon brushes, enabling the BL motor to run cooler and more efficiently for longer life
- Variable 2-speed (0-500 & 0-1,700 RPM) for a wide range of drilling and fastening applications
- Convenient 6.35 mm (1/4") Hex chuck for quick bit changes
- BL motor is electronically controlled to optimize battery energy use for up to 50% longer run time per charge



LXT BL MOTOR XPT



Belt Clip, Phillips Bit

Capacity	Steel / Wood: 13 / 36 mm (1/2" / 1-7/16")
Chuck capacity	6.35 mm (1/4")
No Load Speed (RPM)	High / Low: 0 - 1,700 / 0 - 500
Max Fastening Torque	Hard / Soft: 40 / 23 N-m (350 / 210 in.lbs.)
Max lock torque	40 N-m (350 in.lbs.)
Vibration Level	Drilling Into Metal: 2.5 m/s ² or less
Sound Pressure Level	77 dB(A)
Dimensions (L x W x H)	124x79x247 mm (4-7/8"x3-1/8"x9-3/4")
Net weight	1.1 - 1.4 kg (2.4 - 3.0 lbs.)

DDF083RFE
DDF083Z

Product Comparison List

Model No.	No load speed 3rd/ 2nd/ 1st or Hi/ Lo (rpm)	Mechanical 3-Speed/ 2-Speed	Torque Setting	Max. fastening torque Hard / Soft (N-m)	Overall length (mm)	Net weight	BL motor
DDF458	0-2,000/ 0-400	2	21	91 / 58	225	2.1 - 2.5 kg (4.7 - 5.4 lbs)	
DDF482	0 - 1,900/ 0 - 600	2	21	62 / 36	185	1.5 - 1.8 kg (3.2 - 4.0 lbs)	
DDF484	0-2,000/ 0-500	2	21	54 / 30	172	1.5 - 1.8 kg (3.3 - 4.0 lbs)	•
DDF485	0 - 1,900 / 0 - 500	2	21	50 / 27	169	1.4 - 1.7 kg (3.1 - 3.8 lbs.)	•
DDF453	0-1,300/ 0-400	2	16	42 / 27	222	1.7 - 2.0 kg (3.7 - 4.4 lbs)	
DDF483	0-1,700/ 0-500	2	20	40 / 23	162	1.2 - 1.6 kg (2.7 - 3.4 lbs)	•
DDF083	0-1,700/ 0-500	2	20	40 / 23	124	1.1 - 1.4 kg (2.4 - 3.0 lbs)	•

DHP458

18V LXT Li-Ion Cordless 13 mm (1/2") 84 N-m (750 in.lbs.) Hammer Driver Drill

440

Cordless Hammer Driver Drill



- Delivers 84 N-m (750 in.lbs.) of Max Torque
- Mechanical 2-speed transmission (0 - 400 & 0 - 2,000 RPM) covers a wide range of drilling, fastening and hammer drilling applications
- Compact design at only 225 mm (8-7/8") long and lightweight for reduced operator fatigue
- Extreme Protection Technology (XPT) is engineered for improved dust and water resistance for operation in harsh conditions
- All metal gears and aluminum gear housing for maximum jobsite durability



LXT XPT



(+)(-) Bit, Side Grip, Depth Rod

Capacity	Steel: 13 mm (1/2") Wood: 76 mm (3") Masonry: 16 mm (5/8")
No Load Speed (RPM)	High: 0-2,000 Low: 0-400
Impacts Per Minute (IPM)	High: 0-30,000 Low: 0-6,000
Max Fastening Torque	Hard / Soft: 91 / 58 N-m
Max lock torque	84 N-m (750 in.lbs.)
Dimensions (L x W x H)	225x79x259 mm (8-7/8"x3-1/8"x10-1/4")
Net weight	2.2 - 2.6 kg (4.9 - 5.7 lbs.)

DHP458RFE

DHP484

18V LXT BL Brushless Cordless 13 mm (1/2") 60 N-m (530 in.lbs.) Hammer Driver Drill

Cordless Hammer Driver Drill



- Delivers up to 55% higher hammer drilling speed than previous model
- Aluminum gear housing creates the impression of rigidity of the machine
- Compact and ergonomic design at only 182 mm (7-1/8") long
- Variable 2-speed (0-500 & 0-2,000 RPM) for a wide range of drilling, fastening and hammer drilling applications
- 0-30,000 IPM for fast hammer drilling in masonry materials



LXT BL MOTOR XPT



Belt Clip, (+)(-) Bit

Capacity	Steel / Wood / Masonry: 13 / 38 / 13 mm (1/2" / 1-1/2" / 1/2")
Chuck capacity	1.5 - 13 mm (1/16 - 1/2")
Impacts Per Minute (IPM)	High / Low: 0 - 30,000 / 0 - 7,500
No Load Speed (RPM)	High / Low: 0 - 2,000 / 0 - 500
Max Fastening Torque	Hard / Soft: 54 / 30 N-m (480 / 270 in.lbs.)
Max lock torque	60 N-m (530 in.lbs.)
Vibration Level	Hammer Drilling into Concrete: 8.0 m/s ² Drilling Into Metal: 2.5 m/s ² or less
Sound Pressure Level	88 dB(A)
Sound Power Level	99 dB(A)
Dimensions (L x W x H)	182x79x261 mm (7-1/8"x3-1/8"x10-1/4")
Net weight	1.6 - 1.9 kg (3.5 - 4.2 lbs.)

DHP484RFE
DHP484Z

DHP482

18V LXT Li-Ion Cordless 13 mm (1/2") 54 N-m (480 in.lbs.) Hammer Driver Drill

440

Cordless Hammer Driver Drill



- High speed model with compact and lightweight design
- Compact overall length: 198 mm for increased maneuverability
- Lightweight for reduced operator fatigue
- Higher speed of 1,900 RPM (High) and 600 RPM (Low)
- Variable 2-speed transmission (0-600 & 0-1,900 RPM) for a wide range of drilling and fastening applications



LXT XPT



Belt Clip, (+)(-) Bit

Capacity	Steel / Wood / Masonry: 13 / 38 / 13 mm (1/2" / 1-1/2" / 1/2")
Chuck capacity	1.5 - 13 mm (1/16 - 1/2")
Impacts Per Minute (IPM)	High / Low: 0 - 28,500 / 0 - 9,000
No Load Speed (RPM)	High / Low: 0 - 1,900 / 0 - 600
Max Fastening Torque	Hard / Soft: 62 / 36 N-m (550 / 320 in.lbs.)
Max lock torque	54 N-m (480 in.lbs.)
Vibration Level	Hammer Drilling into Concrete: 6.0 m/s ²
Drilling Into Metal:	2.5 m/s ² or less
Dimensions (L x W x H)	198x79x249 mm (7-3/4"x3-1/8"x9-3/4")
Net weight	1.5 - 1.8 kg (3.4 - 4.1 lbs.)

DHP482RME
DHP482RFX1

DHP482RFE
DHP482Z

DHP485

18V LXT BL Brushless Cordless 13 mm (1/2") 50 N-m (440 in.lbs.) Hammer Driver Drill

Cordless Hammer Driver Drill



- Max 1,900 RPM, 28,500 IPM & 50 N-m (440 in.lbs.) for Increased Efficiency
- Compact design for reduced operator fatigue
- Dual LED lights with preglow and afterglow functions illuminate the work area
- Ergonomically designed grip for comfortable handling
- Variable 2-speed (0-500 & 0-1,900 RPM) for a wide range of drilling, fastening and hammer drilling applications



LXT BL MOTOR XPT



Belt Clip, (+)(-) Bit

Capacity	Steel / Wood / Masonry: 13 / 38 / 13 mm (1/2" / 1-1/2" / 1/2")
Chuck capacity	1.5 - 13 mm (1/16 - 1/2")
Impacts Per Minute (IPM)	High / Low: 0 - 28,500 / 0 - 7,500
No Load Speed (RPM)	High / Low: 0 - 1,900 / 0 - 500
Max Fastening Torque	Hard / Soft: 50 / 27 N-m (440 / 240 in.lbs.)
Max lock torque	50 N-m (440 in.lbs.)
Vibration Level	Hammer Drilling into Concrete: 8.0 m/s ²
Drilling Into Metal:	2.5 m/s ² or less
Sound Pressure Level	82 dB(A)
Sound Power Level	93 dB(A)
Dimensions (L x W x H)	w/ BL1815N / BL1820B: 182x79x237 mm (7-1/8"x3-1/8"x9-3/8") w/ BL1830B / BL1840B / BL1850B / BL1860B: 182x79x255 mm (7-1/8"x3-1/8"x10")
Net weight	1.5 - 1.8 kg (3.2 - 3.9 lbs.)

DHP485RFE

DHP485Z

DHP453

18V LXT Li-Ion Cordless 13 mm (1/2") 38 N-m (340 in.lbs.) Hammer Driver Drill

Cordless Hammer Driver Drill



- Compact and lightweight design
- Variable 2-speed design (0-400 & 0-1,300 RPM) covers a wide range of drilling, driving and hammer applications
- All metal gear construction ensures high transmission durability
- Single sleeve keyless chuck enables easy bit installation/removal with one hand
- Ergonomically designed rubberized soft grip provides more control and comfort



LXT



(+)(-) Bit

Capacity	Steel: 13 mm (1/2") Wood: 36 mm (1-7/16") Masonry: 13 mm (1/2")
Impacts Per Minute (IPM)	High: 0-19,500 Low: 0-6,000
No Load Speed (RPM)	High: 0-1,300 Low: 0-400
Max Fastening Torque	Hard / Soft: 42 / 27 N-m
Max lock torque	38 N-m (340 in.lbs.)
Dimensions (L x W x H)	240x79x244 mm (9-7/16"x3-1/8"x9-5/8")
Net weight	1.7 - 2 kg (3.6 - 4.4 lbs.)

DHP453RFX4
DHP453SFX4

DHP453SFE
DHP453SYE

DHP483

18V LXT BL Brushless Cordless 13 mm (1/2") 40 N-m (350 in.lbs.) Hammer Driver Drill

Cordless Hammer Driver Drill



- Ultra-compact and ergonomic design at only 176 mm long and lightweight for reduced operator fatigue
- BL motor eliminates carbon brushes, enabling the BL motor to run cooler and more efficiently for longer life
- Variable 2-speed (0-500 & 0-1,700 RPM) for a wide range of drilling, fastening and hammer drilling applications
- 0-25,500 IPM for fast hammer drilling in masonry materials
- BL motor is electronically controlled to optimize battery energy use for up to 50% longer run time per charge



LXT BL MOTOR XPT



Belt Clip, (+)(-) Bit

Capacity	Steel / Wood / Masonry: 13 / 36 / 13 mm (1/2" / 1-7/16" / 1/2")
Chuck capacity	1.5 - 13 mm (1/16 - 1/2")
Impacts Per Minute (IPM)	High / Low: 0 - 25,500 / 0 - 7,500
No Load Speed (RPM)	High / Low: 0 - 1,700 / 0 - 500
Max Fastening Torque	Hard / Soft: 40 / 23 N-m (350 / 210 in.lbs.)
Max lock torque	40 N-m (350 in.lbs.)
Vibration Level	Hammer Drilling into Concrete: 10.0 m/s ²
Drilling into Metal:	2.5 m/s ² or less
Sound Pressure Level	83 dB(A)
Sound Power Level	94 dB(A)
Dimensions (L x W x H)	176x79x247 mm (6-15/16"x3-1/8"x9-3/4")
Net weight	1.3 - 1.6 kg (2.8 - 3.6 lbs.)

Net Weight: With BL1815N / BL1820(B), Dimensions: With BL1830(B) / BL1840(B) / BL1850(B) / BL1860(B)

DHP483RFE
DHP483Z

Product Comparison List

Model No.	No load speed 3rd/ 2nd/ 1st or Hi/ Lo (rpm)	Mechanical 3-Speed/ 2-Speed	Torque Setting	Max. fastening torque Hard / Soft (N-m)	Overall length (mm)	Net weight	BL motor
DHP458	0-2,000/ 0-400	2	21	91 / 58	225	2.2 - 2.6 kg (4.9 - 5.7 lbs)	
DHP482	0 - 1,900/ 0 - 600	2	21	62 / 36	198	1.5 - 1.8 kg (3.4 - 4.1 lbs)	
DHP484	0-2,000/ 0-500	2	21	54 / 30	182	1.6 - 1.9 kg (3.5 - 4.2 lbs)	•
DHP485	0 - 1,900 / 0 - 500	2	21	50 / 27	182	1.5 - 1.8 kg (3.2 - 3.9 lbs.)	•
DHP453	0-1,300/ 0-400	2	16	42 / 27	240	1.7 - 2.0 kg (3.6 - 4.4 lbs)	
DHP483	0-1,700/ 0-500	2	20	40 / 23	176	1.3 - 1.6 kg (2.8 - 3.6 lbs)	•

Cordless Impact Driver

DTD171

4 assist mode + 4 impact force to improve work efficiency

Enhanced Anvil holder

Material change from Needle bearing to Ball bearing provides reduction of bit wobbling.

+ 8 Tightening modes and Memory function for various applications



Wood

Tightening long screws.
(0 - 1,800 / 3,800)



The tool drives a screw with low-speed rotation at first. After starting to impact, the rotation speed increases and reaches max speed.

Bolt

Loosening bolts.
(0 - 3,600 / 3,800)

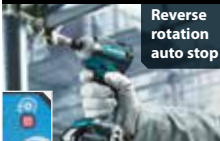

This mode helps to prevent a bolt from falling off.

T1 Teks screw thin metal

Driving self-drilling screws to a thin metal like a metal stud.
(0 - 2,900 / -)



The tool stops rotating soon after impact starts.

T2 Teks screw thick metal

Driving self-drilling screws to a thick metal plate with good finish.
(0 - 3,600 / 2,600)



This mode helps to prevent the screws from breakage and stripping.

4 Changing the impact force (panel button)



4 Assist mode (panel button)

Max

(0 - 3,600 / 3,800)



Hard

(0 - 3,200 / 3,600)



Medium

(0 - 2,100 / 2,600)



Soft

(0 - 1,100 / 1,100)



A-mode (Assist mode)

Max tightening torque

180N·m

Quick mode-switching function (body button)

Impact force change with one hand



Memory function of impact mode is equipped.



Left-right twin LED job light with preglow and afterglow functions

enhances the visibility by reducing the shade of a bit.



predecessor model



LED light ON-OFF button

BL MOTOR

High Power and High Speed

DTD171

Cordless Impact Driver

18V LXT BL Brushless Cordless Wood/Bolt/T-Mode 4-Speed 180 N·m Impact Driver



- 8-mode Operation for Wood/Bolt/T-Mode (1, 2)/Max/Hard/Medium/Soft Impact Mode for Multiple Applications
- Redesigned mode selection switch for one-handed mode selection
- ULTRA-COMPACT and perfect balance at only 116 mm long for maximum control and maneuverability
- Rigid anvil retention for reduced bit wobbling
- Dual LED lights on both sides illuminate the work area for increased visibility



LXT BL MOTOR XPT



Belt Clip

Capacity	Machine Screw: M4 - M8 (5/32" - 5/16")
	Standard Bolt: M5 - M16 (3/16" - 5/8")
	High Tensile Bolt: M5 - M14 (3/16" - 9/16")
Hex Shank	Coarse thread (in length): 22 - 125 mm (7/8" - 4-7/8")
	6.35 mm (1/4")
No Load Speed (RPM)	Max / Hard / Med / Soft / T mode: 0 - 3,600 / 3,200 / 2,100 / 1,100 / 3,600
Impacts Per Minute (IPM)	Max / Hard / Med / Soft / T mode: 0 - 3,800 / 3,600 / 2,600 / 1,100 / 2,600
Max Fastening Torque	180 N·m (1,590 in.lbs.)
Vibration Level	Impact tightening of fasteners of the maximum capacity of the tool: 13.5 m/s ²
Sound Pressure Level	97 dB(A)
Sound Power Level	108 dB(A)
Dimensions (L x W x H)	w/ BL1815N / BL1820B: 116x79x218 mm (4-9/16"x3-1/8"x8-5/8") w/ BL1830B / BL1840B / BL1850B / BL1860B: 116x79x236 mm (4-9/16"x3-1/8"x9-1/4")
Net weight	1.2 - 1.6 kg (2.7 - 3.4 lbs.)

DTD171RFJ
DTD171Z

DTD156

18V LXT Li-Ion Cordless 155 N-m (1,370 in.lbs.) Impact Driver

5

Cordless Impact Driver



new

- Aluminum hammer case for creating the impression of rigidity
- Compact design with a short overall length of 143mm (5-5/8")
- Variable speed (0-2,500 RPM & 0-3,000 IPM) provides 155 N-m (1,370 in.lbs.) of Max Torque for a wide range of fastening applications
- Compact, lightweight but powerful 4-pole motor
- Rubberized soft grip provides increased comfort on the job



LXT



Belt Clip, Battery, Charger

Capacity	Machine Screw: M4 - M8 (5/32" - 5/16") Standard Bolt: M5 - M14 (3/16" - 9/16") High Strength Bolt: M5 - M12 (3/16" - 1/2")
	Coarse thread (in length): : 22 - 125 mm (7/8" - 4-7/8")
Hex Shank	6.35 mm (1/4")
No Load Speed (RPM)	0 - 2,500
Impacts Per Minute (IPM)	0 - 3,000
Max Fastening Torque	155 N-m (1,370 in.lbs.)
Vibration Level	10.0 m/s ²
Sound Pressure Level	92 dB(A)
Sound Power Level	103 dB(A)
Dimensions (L x W x H)	w/ BL1830B / BL1840B / BL1850B / BL1860B : 143x79x241 mm (5-5/8"x3-1/8"x9-1/2")
Net weight	1.3 - 1.6 kg (2.9 - 3.6 lbs.)

DTD156SFE
DTD156Z

DTD154

18V LXT BL Brushless Cordless T-Mode 3-Speed 175 N-m (1,550 in.lbs.) Impact Driver

Cordless Impact Driver



- ULTRA-COMPACT and ergonomic design at only 117 mm long
- Aluminum hammer case creates the impression of rigidity of the machine
- Dual LED lights with preglow and afterglow functions illuminate the work area more widely
- T-mode has an automatic electronic controller that downshifts and reduces rotation and impact speed prior to driving screw into place, and is engineered to minimize screw thread stripping, screw breakage and damage to work
- BL motor delivers 3,600 Max RPM and 175 N-m (1,550 in.lbs.) of Max Torque



LXT BL MOTOR XPT



Belt Clip

Capacity	Machine Screw: M4 - M8 (5/32" - 5/16") Standard Bolt: M5 - M16 (3/16" - 5/8") High Tensile Bolt: M5 - M14 (3/16" - 9/16")
	Coarse thread (in length): : 22 - 125 mm (7/8" - 4-7/8")
Hex Shank	6.35 mm (1/4")
No Load Speed (RPM)	0 - 3,600 / 0 - 2,100 / 0 - 1,100
Impacts Per Minute (IPM)	0 - 3,800 / 0 - 2,600 / 0 - 1,100
Max Fastening Torque	175 N-m (1,550 in.lbs.)
Vibration Level	12.5 m/s ²
Sound Pressure Level	96 dB(A)
Sound Power Level	107 dB(A)
Dimensions (L x W x H)	117x79x236 mm (4-5/8"x3-1/8"x9-1/4")
Net weight	1.3 - 1.6 kg (2.7 - 3.4 lbs.)

DTD154RFE
DTD154Z

DTD153

18V LXT BL Brushless Cordless 170 N-m (1,500 in.lbs.) Impact Driver

Cordless Impact Driver



- Higher speed 3,400 RPM, More powerful 170 N-m (1,500 in.lbs.) and More compact 126 mm long
- BL motor delivers 3,400 max RPM and 170 N-m (1,500 in.lbs.) of max torque
- Compact and lightweight design
- Aluminum hammer case creates the impression of rigidity of the machine
- Dual LED lights with preglow and afterglow functions illuminate the work area more widely



LXT BL MOTOR XPT



Belt Clip

Capacity	Machine Screw: M4 - M8 (5/32" - 5/16") Standard Bolt: M5 - M16 (3/16" - 5/8") High Tensile Bolt: M5 - M14 (3/16" - 9/16")
	Coarse thread (in length): : 22 - 125 mm (7/8" - 4-7/8")
Hex Shank	6.35 mm (1/4")
No Load Speed (RPM)	0 - 3,400
Impacts Per Minute (IPM)	0 - 3,600
Max Fastening Torque	170 N-m (1,500 in.lbs.)
Vibration Level	13.0 m/s ²
Sound Pressure Level	96 dB(A)
Sound Power Level	107 dB(A)
Dimensions (L x W x H)	126x79x238 mm (5"x3-1/8"x9-3/8")
Net weight	1.3 - 1.6 kg (2.8 - 3.5 lbs.)

DTD153RFE
DTD153Z

DTD152

18V LXT Li-Ion Cordless 165 N-m (1,460 in.lbs.) Impact Driver

448

Cordless Impact Driver



- Developed for main applications such as tightening of self-drilling screws or light duty machine screws
- Delivers 2,900 max RPM and 165 N-m (1,460 in.lbs.) of max torque
- Compact and lightweight design
- Aluminum hammer case creates the impression of rigidity of the machine
- Dual LED lights with preglow and afterglow functions illuminate the work area more widely

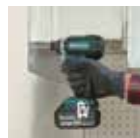

LXT XPT



Belt Clip

Capacity	Machine Screw: M4 - M8 (5/32" - 5/16") Standard Bolt: M5 - M16 (3/16" - 5/8") High Tensile Bolt: M5 - M12 (3/16" - 1/2")
	Coarse thread (in length): : 22 - 125 mm (7/8" - 4-7/8")
Hex Shank	6.35 mm (1/4")
No Load Speed (RPM)	0 - 2,900
Impacts Per Minute (IPM)	0 - 3,500
Max Fastening Torque	165 N-m (1,460 in.lbs.)
Vibration Level	10.5 m/s ²
Sound Pressure Level	93 dB(A)
Sound Power Level	104 dB(A)
Dimensions (L x W x H)	137x79x238 mm (5-3/8"x3-1/8"x9-3/8")
Net weight	1.3 - 1.6 kg (2.8 - 3.5 lbs.)

DTD152SFE3
DTD152STE

DTD152RME
DTD152RFE
DTD152Z

DTD155

18V LXT BL Brushless Cordless A-Mode (Assist Mode) 140 N-m (1,240 in.lbs.) Impact Driver

Cordless Impact Driver



- 3-Mode operation for A-mode / Hard mode / Soft mode for multiple applications
- A-mode feature helps eliminate "screw cam-out" and "cross threading" by driving at low speed until tightening begins
- Variable speed (0-1,300/0-3,000 RPM & 0-1,600/0-3,900 IPM) for a wide range of fastening applications
- BL motor is electronically controlled to optimize battery energy use for up to 50% longer run time per charge
- BL motor eliminates carbon brushes, enabling the BL motor to run cooler and more efficiently for longer life



LXT BL MOTOR XPT



Belt Clip

Capacity	Machine Screw: M4 - M8 mm (5/32" - 5/16") Standard Bolt: M5 - M14 (3/16" - 9/16") High Tensile Bolt: M5 - M12 (3/16" - 1/2")
	Coarse thread (in length): : 22 - 90 mm (7/8" - 3-1/2")
Hex Shank	6.35 mm (1/4")
No Load Speed (RPM)	Hard / Soft: 0 - 3,000 / 0 - 1,300
Impacts Per Minute (IPM)	Hard / Soft: 0 - 3,900 / 0 - 1,600
Max Fastening Torque	140 N-m (1,240 in.lbs.)
Vibration Level	Impact tightening of fasteners of the maximum capacity of the tool: 14.0 m/s ²
Sound Pressure Level	94 dB(A)
Sound Power Level	105 dB(A)
Dimensions (L x W x H)	135x79x232 mm (5-1/16"x3-1/8"x9-1/8")
Net weight	1.2 - 1.5 kg (2.6 - 3.2 lbs.)

DTD155RTE
DTD155RFE

DTD155Z

Product Comparison List

Model No.	No load speed (rpm)	Electronic-Speed	Max. fastening torque (N-m)	Overall length (mm)	Net weight	BL motor
Cordless Impact Driver						
DTD171	0 - 3,600 / 3,200 / 2,100 / 1,100 / 1,800 / 3,600 / 2,900 / 3,600	8-Speed	180	116	1.2 - 1.6 kg (2.7 - 3.4 lbs.)	●
DTD156	0 - 2,500		155	143	1.3 - 1.6 kg (2.9 - 3.6 lbs)	●
DTD154	0 - 3,600 / 0 - 2,100 / 0 - 1,100	3-Speed	175	117	1.3 - 1.6 kg (2.7 - 3.4 lbs)	●
DTD153	0 - 3,400		170	126	1.3 - 1.6 kg (2.8 - 3.5 lbs)	●
DTD152	0 - 2,900		165	137	1.3 - 1.6 kg (2.8 - 3.5 lbs)	●
DTD155	0 - 3,000 / 0 - 1,300	2-Speed	140	135	1.2 - 1.5 kg (2.6 - 3.2 lbs)	●

DTW1001 18V LXT BL Brushless Cordless 3-Speed 3/4" (19 mm) 1,050 N-m (780 ft.lbs.) Impact Wrench

Cordless Impact Wrench



- Makita's Most Powerful Impact Wrench
- Compact and lightweight design thanks to BL motor
- Extremely high power equivalent to AC model TW1000
- Overall length is extremely shortened
- Electronic 3 stage impact power selection reduces fault tightening

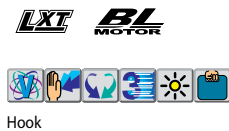

Fastening Capacities	Standard Bolt: M12 - M30 (1/2" - 1-1/4") High Tensile Bolt: M10 - M24 (3/8" - 1")
Square Drive	19 mm (3/4")
No Load Speed (RPM)	Hard / Med / Soft: 0 - 1,800 / 0 - 1,000 / 0 - 900
Impacts Per Minute (IPM)	Hard / Med / Soft: 0 - 2,200 / 0 - 2,000 / 0 - 1,800
Max Fastening Torque	1,050 N-m (780 ft.lbs.)
Vibration Level	Impact tightening of fasteners of the maximum capacity of the tool: 15.5 m/s ²
Sound Pressure Level	98 dB(A)
Sound Power Level	109 dB(A)
Dimensions (L x W x H)	229x91x289 mm (9"x3-5/8"x11-3/8")
Net weight	3.4 - 3.7 kg (7.5 - 8.2 lbs.)

DTW1001RFJ
DTW1001Z

DTW1002 18V LXT BL Brushless Cordless 3-Speed 1/2" (12.7 mm) 1,000 N-m (740 ft.lbs.) Impact Wrench

Cordless Impact Wrench



- Makita's Most POWERFUL 1,000 N-m (740 ft.lbs.) 1/2" Impact Wrench / Compact and Lightweight design thanks to BL motor
- Extremely high power equivalent to AC model TW1000
- Overall length is extremely shortened
- Electronic 3 stage impact power selection reduces fault tightening
- Hammer case securely fastened with four bolts

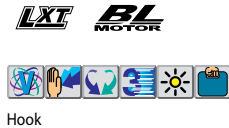

Fastening Capacities	Standard Bolt: M12 - M30 (1/2" - 1-1/4") High Tensile Bolt: M10 - M24 (3/8" - 1")
Square Drive	12.7 mm (1/2")
No Load Speed (RPM)	Hard / Med / Soft: 0 - 1,800 / 0 - 1,000 / 0 - 900
Impacts Per Minute (IPM)	Hard / Med / Soft: 0 - 2,200 / 0 - 2,000 / 0 - 1,800
Max Fastening Torque	1,000 N-m (740 ft.lbs.)
Vibration Level	Impact tightening of fasteners of the maximum capacity of the tool: 18.0 m/s ²
Sound Pressure Level	97 dB(A)
Sound Power Level	108 dB(A)
Dimensions (L x W x H)	229x91x289 mm (9"x3-5/8"x11-3/8")
Net weight	3.3 - 3.6 kg (7.3 - 8.0 lbs.)

DTW1002RFJ
DTW1002Z

DTW700 18V LXT BL Cordless 1/2" (12.7 mm) 700 N-m (520 ft.lbs.) Impact Wrench, Forward/Reverse Rotation Auto Stop Mode

Cordless Impact Wrench



new

- Increased rotation speed delivers higher torque than DTW450
- 3 modes of reaction time for automatic stop available both in forward and reverse rotation modes
- Trigger switch with full speed mode allows for less hand and finger fatigue
- Compact design with a short overall length of 170 mm (6-11/16")
- Socket can be fixed with C-ring (ring spring)
- BL motor delivers 700 N-m (520 ft.lbs.) of max torque
- BL motor is electronically controlled to optimize battery energy use for longer run time per charge

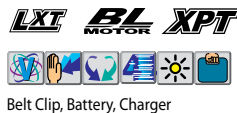

Fastening Capacities	Standard Bolt: M10 - M24 (3/8 - 1") High Strength Bolt (Grade 10.9): M10 - M16 (3/8 - 5/8")
Square Drive	12.7 mm (1/2")
No Load Speed (RPM)	Max / Hard / Mid / Soft: 0 - 2,200 / 1,900 / 1,200 / 500
Impacts Per Minute (IPM)	Max / Hard / Mid / Soft: 0 - 2,700 / 2,400 / 1,700 / 1,000
Max Fastening Torque	700 N-m (520 ft.lbs.)
Vibration Level	Impact tightening of fasteners of the maximum capacity of the tool: 19.0 m/s ²
Sound Pressure Level	94 dB(A)
Sound Power Level	105 dB(A)
Dimensions (L x W x H)	w/ BL1815N / BL1820B: 170 x 81 x 258 mm (6-11/16 x 3-3/16 x 10")
Net weight	2.3 - 2.7 kg (5.1 - 6.0 lbs.)

DTW700RTJ
DTW700Z

DTW450 18V LXT Li-Ion Cordless 1/2" (12.7 mm) 440 N-m (325 ft.lbs.) Impact Wrench

Cordless Impact Wrench



- Delivers 440 N-m (325 ft.lbs.) of torque for tough jobs
- Top no load speed 1,600 RPM creates 2,200 IPM
- Powerful DC motor with replaceable carbon brush for economic repair and maintenance
- Compact and lightweight design provides superior balance and control
- Large rocker switch for more convenience and comfort



Fastening Capacities	Standard Bolt: M12 - M22 (1/2" - 7/8") High Tensile Bolt: M12 - M16 (1/2" - 5/8")
Square Drive	12.7 mm (1/2")
No Load Speed (RPM)	1,600
Impacts Per Minute (IPM)	2,200
Max Fastening Torque	440 N-m (325 ft.lbs.)
Vibration Level	Impact tightening of fasteners of the maximum capacity of the tool: 19 m/s ²
Sound Pressure Level	94 dB(A)
Sound Power Level	105 dB(A)
Dimensions (L x W x H)	266x82x290 mm (10-1/2 "x3-1/4"x11-3/8")
Net weight	3.1 - 3.4 kg (7.6 - 6.9 lbs.)

DTW450RFE
DTW450Z

18V Cordless

DTW300

Cordless Impact Wrench



new

- High torque
- Reverse rotation auto stop mode stops after the bolt/nut loosened enough
- Single speed mode for reduced trigger-pulling force
- Socket can be fixed with ring spring (DTW300)
- Socket can be fixed with pin (DTW301)
- BL motor delivers 330 N-m (240 ft.lbs.) of max torque



LXT BL MOTOR XPT



Belt Clip, Battery, Charger

Fastening Capacities	Standard Bolt: M10 - M20 (3/8" - 3/4")
	High Strength Bolt: M10 - M16 (3/8" - 5/8")
Square Drive	12.7 mm (1/2")
No Load Speed (RPM)	0-3,200/0-1,700/0-1,300/0-1,000
Impacts Per Minute (IPM)	0-4,000/0-2,200/0-1,700/0-1,300
Max Fastening Torque	330 N-m (240 ft.lbs.)
Dimensions (L x W x H)	w/ BL1815N / BL1820B: 144x81x228 mm (5-5/8"x3-3/16"x9")
	w/ BL1830B / BL1840B / BL1850B / BL1860B: 144x81x246 mm (5-5/8"x3-3/16"x9-11/16")
Net weight	1.5 - 1.8 kg (3.3 - 4.0 lbs.)

DTW300RTJ
DTW300Z

DTW285

Cordless Impact Wrench



- Reverse Rotation Auto Stop Mode Stops Rotation and Impact in 0.2 Seconds when Fastener Is Loosened Adequately to Prevent Bolt/Nut Get Lost
- BL motor delivers 280 N-m (210 ft.lbs.) of max torque
- BL motor is electronically controlled to optimize battery energy use for up to 50% longer run time per charge
- BL motor eliminates carbon brushes, enabling the BL motor to run cooler and more efficiently for longer life
- BL motor efficiently uses energy to match torque and RPM to the changing demands of the application



LXT BL MOTOR XPT



Belt Clip

Fastening Capacities	Standard Bolt: M10 - M20 (3/8" - 3/4")
	High Tensile Bolt: M10 - M16 (3/8" - 5/8")
Square Drive	12.7 mm (1/2")
No Load Speed (RPM)	Hard / Med / Soft: 0 - 2,800 / 0 - 2,100 / 0 - 1,600
Impacts Per Minute (IPM)	Hard / Med / Soft: 0 - 3,500 / 0 - 2,600 / 0 - 1,800
Max Fastening Torque	280 N-m (210 ft.lbs.)
Vibration Level	Impact tightening of fasteners of the maximum capacity of the tool: 11.5 m/s ²
Sound Pressure Level	96 dB(A)
Sound Power Level	107 dB(A)
Dimensions (L x W x H)	147x79x249 mm (5-3/4"x3-1/8"x9-3/4")
Net weight	1.5 - 1.8 kg (3.2 - 3.9 lbs.)

DTW285SFE3
DTW285RFJX
DTW285RTEDTW285RFE
DTW285Z

DTW251

Cordless Impact Wrench



- High torque to weight ratio at 230 N-m (170 ft.lbs.)
- Makita built 4-pole motor design with dual steel ball bearings provides maximum torque
- Compact body provides more control and maneuverability
- High power, compact and lightweight 4-pole motor
- Electric brake for increased operator safety



LXT



Fastening Capacities	Standard Bolt: M10 - M16 (3/8" - 5/8")
	High Tensile Bolt: M10 - M14 (3/8" - 9/16")
Square Drive	12.7 mm (1/2")
No Load Speed (RPM)	0 - 2,100
Impacts Per Minute (IPM)	0 - 3,200
Max Fastening Torque	230 N-m (170 ft.lbs.)
Vibration Level	Impact tightening of fasteners of the maximum capacity of the tool: 11.0 m/s ²
Sound Pressure Level	94 dB(A)
Sound Power Level	105 dB(A)
Dimensions (L x W x H)	165x79x234 mm (6-1/2"x3-1/8"x9-1/4")
Net weight	1.5 - 1.8 kg (3.2 - 3.9 lbs.)

Tool does not come with socket.

DTW251RMJ
DTW251RMEDTW251RFE
DTW251Z

DTW190

Cordless Impact Wrench



- 190 N-m (140 ft.lbs.) of Max torque optimal for scaffold building
- Shoulder strap improves freedom of operator's movement during work at height
- 0-2,300 RPM & 0-3,000 IPM for a wide range of fastening applications
- Compact and ergonomic design at only 176 mm long
- Lightweight for reduced operator fatigue



LXT



Shoulder Strap (country-specific), Tool Hanger (country-specific)

Fastening Capacities	Standard Bolt: M8 - M16 (5/16" - 5/8")
	High Tensile Bolt: M8 - M12 (5/16" - 1/2")
Square Drive	12.7 mm (1/2")
No Load Speed (RPM)	0 - 2,300
Impacts Per Minute (IPM)	0 - 3,000
Max Fastening Torque	190 N-m (140 ft.lbs.)
Vibration Level	Impact tightening of fasteners of the maximum capacity of the tool: 8.5 m/s ²
Sound Pressure Level	94 dB(A)
Sound Power Level	105 dB(A)
Overall Length	176 mm (6-15/16")
Net weight	1.4 - 1.8 kg (3.2 - 3.9 lbs.)

Tool does not come with socket.

DTW190SFE3
DTW190RFE
DTW190JX1DTW190SFX1
DTW190SFX7
DTW190Z

DTW181

Cordless Impact Wrench



- Reverse rotation auto stop mode; stops in 0.2 seconds after the bolt/ nut gets loosened enough.
- Max fastening torque: 210 N-m
- Lightweight with a compact width at BL motor section



LXT BL MOTOR XPT



Belt Clip

Fastening Capacities	Standard Bolt: M8 - M16 (5/16" - 5/8")
	High Tensile Bolt: M6 - M12 (1/4" - 1/2")
Square Drive	12.7mm (1/2")
No Load Speed (RPM)	Hard / Soft: 0 - 2,400 / 0 - 1,300
Impacts Per Minute (IPM)	Hard / Soft: 0 - 3,600 / 0 - 2,000
Max Fastening Torque	210 N-m (130 ft.lbs.)
Vibration Level	Impact tightening of fasteners of the maximum capacity of the tool: 9.0 m/s ²
Sound Pressure Level	95 dB(A)
Sound Power Level	106 dB(A)
Dimensions (L x W x H)	w/ BL1815N / BL1820B: 144x79x218 mm (5-5/8"x3-1/8"x8-5/8")
	w/ BL1830B / BL1840B / BL1850B / BL1860B: 151x79x235 mm (5-5/8"x3-1/8"x9-1/4")
Net weight	1.2 - 1.5 kg (2.7 - 3.4 lbs.)

DTW181RTE
DTW181RFE

DTW181Z

Product Comparison List

Model No.	Square drive	Max tightening torque N-m (ft.lbs)	No load speed (rpm)	Overall length (mm)	Net weight	BL motor
DTW1001	3/4" (19mm)	1,050 (780)	0-1,800/ 0-1,000 / 0-900	229	3.4 - 3.7 kg (7.5 - 8.2 lbs)	●
DTW1002	1/2" (12.7mm)	1,000 (740)	0-1,800/ 0-1,000 / 0-900	229	3.3 - 3.6 kg (7.3 - 8.0 lbs)	●
DTW700						
DTW450	1/2" (12.7mm)	440 (325)	1,600	266	3.1 - 3.4 kg (7.6 - 6.9 lbs)	
DTW300	0-3,200/0-1,700/0-1,300/0-1,000	330 (240)	1/2" (12.7mm)	144	1.5 - 1.8 kg (3.3 - 4.0 lbs.)	●
DTW181	1/2" (12.7mm) Hex.	210 (155)	0 - 2,400 / 0 - 1,300	151	1.2 - 1.5 kg (2.7 - 3.4 lbs.)	●
DTW285	1/2" (12.7mm)	280 (210)	0-2,800/ 0-2,100/ 1,600	147	1.5 - 1.8 kg (3.2 - 3.9 lbs)	●
DTW251	1/2" (12.7mm)	230 (170)	0-2,100	165	1.5 - 1.8 kg (3.2 - 3.9 lbs)	
DTW190	1/2" (12.7mm)	190 (140)	0-2,300	176	1.4 - 1.8 kg (3.2 - 3.9 lbs)	

DWR180 18V LXT Li-Ion Cordless 47.5 N-m (420 in.lbs.) Ratchet Wrench

Cordless Ratchet Wrench

new



- Supplied with two socket adapters for compatibility with a variety of sockets
- Equipped with lock-pin style ratchet mechanism is employed, allowing for use as a pass-through ratchet wrench to tighten 13mm nut onto M8 threaded rod
- Easy-to-grip small diameter grip for more comfort and control
- 47.5 N-m (420 in.lbs.) of maximum torque and 0-800 RPM
- Fastens nuts on threaded rods
- Can be also used as a hand ratchet wrench
- LED light with preglow and afterglow functions illuminates the work area

Capacity	Standard Bolt: M5 - M12 (3/16 - 1/2") High Strength Bolt : M5 - M10 (3/16 - 3/8")
Square Drive	9.5 / 6.35 mm (3/8" / 1/4")
No Load Speed (RPM)	0 - 800
Max Fastening Torque	47.5 N-m (420 in.lbs.)
Dimensions (L x W x H)	w/ BL1830B / BL1840B / BL1850B / BL1860B : 369 x 79 x 87 mm (14-1/2 x 3-1/8 x 3-7/16")
Net weight	1.2 - 1.6 kg (2.6 - 3.5 lbs.)



LXT XPT



Socket Adapter, Battery, Charger, Tool Bag

DWR180RF

DWR180Z

Supplied with two socket adapters

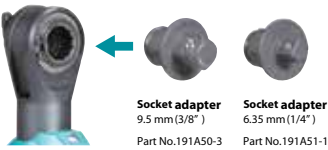

Socket adapter 9.5 mm (3/8") Part No.191A50-3
Socket adapter 6.35 mm (1/4") Part No.191A51-1

Easy-to-grip small diameter grip for more comfort and control



Can also be used as a hand ratchet wrench

XPT EXTREME PROTECTION TECHNOLOGY **18V LITHIUM-ION**

Forward / reverse rotation change

Turn the reversing lever to the A side for clockwise rotation or to the B side for counterclockwise rotation.

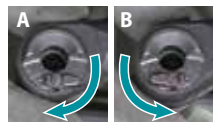

Able to tighten 13mm nut onto M8 threaded rod

13mm nut only



Single LED job light with preglow and afterglow functions



Tool bag

Part No. 832074-1



DTL063 18V LXT Li-Ion Cordless 3/8" (9.5 mm) 60 N-m Angle Impact Wrench

Cordless Angle Impact Wrench



- Compact right angle impact wrench for fastening and loosening in tight spaces
- Makita built motor and impact mechanism produces 60 N-m (531 in.lbs.) of maximum torque and 0-3,000 IPM
- Variable speed (0-2,000 RPM) for a range of applications from auto repair to product assembly
- Large conveniently located paddle switch for comfortable operation
- Over one foot of tool extension for extra reach into tight spaces

Fastening Capacities	Standard Bolt: M4 - M12 (5/32" - 1/2") High Tensile Bolt: M4 - M8 (5/32" - 5/16")
Square Drive	9.5 mm (3/8")
No Load Speed (RPM)	0 - 2,000
Impacts Per Minute (IPM)	0 - 3,000
Max Fastening Torque	60 N-m
Vibration Level	Impact tightening of fasteners of the maximum capacity of the tool: 16.5 m/s ²
Sound Pressure Level	88 dB(A)
Sound Power Level	99 dB(A)
Dimensions (L x W x H)	387x78x116 mm (15-1/4"x3-1/16"x4-9/16")
Net weight	1.4 - 2.0 kg (3.1 - 4.3 lbs.)



LXT



DTL063Z

DFS250

Cordless Screwdriver



18V LXT BL Brushless Cordless 0-2,500 RPM High Torque Push Drive Technology Screwdriver with LED Light, Silent Clutch

- High torque ideal for decking applications
- Push Drive Technology - in lock-on mode the motor starts only when the fastener is engaged for a quieter work environment and to save battery power
- Ultra-high efficiency comparable to AC screwdrivers
- BL motor eliminates carbon brushes, enabling the BL motor to run cooler and more efficiently for longer life
- BL motor is electronically controlled to optimize battery energy use for up to 50% longer run time per charge



LXT BL MOTOR



Phillips Bit, Magnetic Bit Holder, Belt Clip

Capacity	Coarse Thread: 4.5 x 90 mm (3/16" x 3-1/2") Self-Drilling Screw: 6 mm (1/4") Drywall Screw: 5 mm (3/16")
Driving Shank (Hex)	6.35 mm (1/4")
No Load Speed (RPM)	0 - 2,500
Vibration Level	Screwdriving w/o Impact: 2.5 m/s ² or less
Sound Pressure Level	72 dB(A)
Dimensions (L x W x H)	259x79x259 mm (10-1/4"x3-1/8"x10-1/4")
Net weight	1.5 - 1.9 kg (3.4 - 4.1 lbs.)

DFS250RFE
DFS250Z

DFS251

Cordless Screwdriver



18V LXT BL Brushless Cordless 0-2,500 RPM High Torque Push Drive Technology Screwdriver with LED Light

- High torque ideal for fastening self-drilling screw
- Push Drive Technology - in lock-on mode the motor starts only when the fastener is engaged for a quieter work environment and to save battery power
- Ultra-high efficiency comparable to AC screwdrivers
- BL motor eliminates carbon brushes, enabling the BL motor to run cooler and more efficiently for longer life
- BL motor is electronically controlled to optimize battery energy use for up to 50% longer run time per charge



LXT BL MOTOR



Magnetic Socket Bit

Capacity	Self-Drilling Screw: 6 mm (1/4") Drywall Screw: 5 mm (3/16") Hex Socket Screw: 6 mm (1/4")
Driving Shank (Hex)	6.35 mm (1/4")
No Load Speed (RPM)	0 - 2,500
Vibration Level	Screwdriving w/o Impact: 2.5 m/s ² or less
Sound Pressure Level	72 dB(A)
Dimensions (L x W x H)	237x79x259 mm (9-3/8"x3-1/8"x11-1/4")
Net weight	1.5 - 1.8 kg (3.2 - 3.9 lbs.)

DFS251RFE
DFS251Z

DHR241

Cordless Combination Hammer



18V LXT Li-Ion Cordless 20 mm (13/16") Combination Hammer, SDS-PLUS Bits

- 0 - 1,100 RPM and 0 - 4,000 BPM for Demanding Applications
- Makita-built variable speed motor delivers 0-1,100 RPM and 0-4,000 BPM
- Synchronized RPM and BPM prevents overlapping impacts for up to 50% more efficient drilling
- 3-Mode operation: "rotation only", "hammering with rotation" or "hammering only"
- Job site tested shock absorbent handle protects the battery housing for durability



LXT



Side Grip, Depth Gauge

Impact Energy	1.9 J
Capacity	Concrete: 20 mm (13/16") Steel: 13 mm (1/2") Wood: 26 mm (1")
Blows Per Minute (BPM)	0 - 4,000
No Load Speed (RPM)	0 - 1,100
Sound Pressure Level	86 dB(A)
Sound Power Level	97 dB(A)
Vibration Level	Hammer Drilling into Concrete: 12.5 m/s ²
Dimensions (L x W x H)	417x84x219 mm (16-3/8"x3-5/16"x8-5/8")
Net weight	3.2 - 4 kg (7.1 - 8.8 lbs.)

DHR241RTE
DHR241RFE

DHR241SYE

DHR202

Cordless Combination Hammer



18V LXT Li-Ion Cordless 20 mm (13/16") Combination Hammer, SDS-PLUS Bits

- Makita-built motor delivers 0-1,100 RPM and 0-4,000 BPM for 2X faster drilling
- Synchronized RPM and BPM prevents overlapping impacts for up to 50% more efficient drilling
- 3-Mode operation: "rotation only", "hammering with rotation" and "hammering only"
- 40 different chisel positions for increased comfort and performance
- Built-in torque limiter clutch disengages motor should bit bind



LXT



Side Grip, Depth Gauge

Capacity	Concrete: 20 mm (13/16") Steel: 13 mm (1/2") Wood: 26 mm (1")
Blows Per Minute (BPM)	0 - 4,000
No Load Speed (RPM)	0 - 1,100
Dimensions (L x W x H)	358x84x259 mm (14-1/8"x3-5/16"x10-1/4")
Net weight	3.2 - 4 kg (7.1 - 8.8 lbs.)

DHR202RFE

DHR182

Cordless Combination Hammer



18V LXT BL AWS AVT Cordless 18 mm (11/16") Combination Hammer, SDS-PLUS Bits

- BL Motor Delivers 0-1,350 RPM, 0-5,000 BPM and 1.7 Joules of Impact Energy for Faster Drilling
- Auto-start Wireless System (AWS) connects to vacuum cleaner with Bluetooth
- Low vibration achieved by Anti-Vibration Technology (AVT)
- Compact and lightweight for reduced operator fatigue
- BL motor with high power to weight and size ratio



LXT BL MOTOR AWS AVT XPT



Dust Cup (country-specific), Side Grip, Depth Gauge

Impact Energy	EPTA-Procedure 05/2009: 1.7 J
Capacity	Concrete: 18 mm (11/16") Steel: 13 mm (1/2") Wood: 24 mm (15/16")
Blows Per Minute (BPM)	0 - 5,000
No Load Speed (RPM)	0 - 1,350
Dimensions (L x W x H)	w/ BL1830B / BL1840B / BL1850B / BL1860B: 301x82x285 mm (11-7/8"x3-1/4"x11-1/4")
Net weight	2.4 - 3.2 kg (5.3 - 7.0 lbs.)

DHR182RTJU
DHR182RTJDHR182ZU
DHR182Z

DHR171

18V LXT BL Brushless Cordless 17 mm (11/16") Rotary Hammer, SDS-PLUS Bits

Cordless Rotary Hammer



- BL Motor Delivers 0-680 RPM, 0-4,800 BPM and 1.2 Joules of Impact Energy for Faster Drilling
- Compact and lightweight for reduced operator fatigue
- Vibration absorbing housing and ergonomic soft rubber grip design for vibration absorption and comfortable operation
- BL motor with high power to weight and size ratio
- BL motor generates less heat buildup and is ideal for prolonged use in high production applications



LXT BL MOTOR



Dust Cup (country-specific), Side Grip, Depth Gauge

Impact Energy	EPTA-Procedure 05/2009: 1.2 J
Capacity	Concrete: 17 mm (11/16") Steel: 10 mm (3/8") Wood: 13 mm (1/2")
Blows Per Minute (BPM)	0 - 4,800
No Load Speed (RPM)	0 - 680
Vibration Level	Hammer Drilling into Concrete: 9.0 m/s ² Drilling Into Metal: 2.5 m/s ² or less
Sound Pressure Level	86 dB(A)
Sound Power Level	97 dB(A)
Dimensions (L x W x H)	w/ BL1815N / BL1820B: 273x86x194 mm (10-3/4"x3-3/8"x7-5/8") w/ BL1830B / BL1840B / BL1850B / BL1860B: 273x86x211 mm (10-3/4"x3-3/8"x8-5/16")
Net weight	2.1 - 2.8 kg (4.6 - 6.2 lbs.)

DHR171RTJ
DHR171Z

DHR165

18V LXT Li-Ion Cordless 16 mm (5/8") Rotary Hammer, SDS-PLUS Bits

430

Cordless Rotary Hammer



- Compact and Light weight
- Ergonomic handle for perfect tool control and minimum hand fatigue and pain
- 2-mode operation for "Rotation Only" or "Hammering with Rotation"
- Side grip with elastomer soft grip
- Conveniently located push button for rotation reverse



LXT XPT



Side Grip, Depth Gauge

Impact Energy	1.3 J
Capacity	Concrete (w/ TCT Bit): 16 mm (5/8") Concrete (w/ Diamond Core Bit): 32 mm (1-1/4") Steel: 13 mm (1/2") Wood: 24 mm (15/16")
Blows Per Minute (BPM)	0 - 5,300
No Load Speed (RPM)	0-1,600
Dimensions (L x W x H)	297x79x253 mm (11-3/4"x3-1/8"x10")
Net weight	2.3 - 3 kg (5 - 6.6 lbs.)

DHR165RFE
DHR165Z

DHK180

18V LXT BL AVT Cordless Power Scraper, SDS-PLUS Bits

Cordless Power Scraper

new



- Anti-vibration housing and AVT for reduced operator fatigue
- BL motor delivers high power
- Compact and lightweight
- Excellent maneuverability
- Twin LED job light



LXT BL MOTOR AVT XPT



Bull Point, Scaling Chisel, Scaling chisel (for tile), Hook

Impact Energy	EPTA-Procedure 05/2009: 3.1 J
Blows Per Minute (BPM)	0 - 3,200
Dimensions (L x W x H)	368x99x211 mm (14-1/2"x3-7/8"x8-5/16")
Net weight	3.3 - 3.6 kg (7.3 - 7.9 lbs.)

DHK180RTJ
DHK180Z

DSL800

18V LXT BL AWS Cordless 225 mm (8-7/8") Variable Speed Drywall Sander

Cordless Drywall Sander



- Auto-Start Wireless System (AWS) Connects to Vacuum Cleaner with Bluetooth
- Constant speed control for smooth finish
- Better maneuverability regardless of user's size by telescopic pipe
- Optional extension handle for high position operation
- Our advanced cordless technology provides greatly increased maneuverability
- BL motor delivers up to 1,800 RPM for faster sanding
- BL motor is electronically controlled to optimize battery energy use for longer run time per charge



LXT BL MOTOR XPT AWS



Abrasive Disc, Hex Wrench, Tool Bag, Wireless Unit (country-specific), Wireless Unit Adapter (country-specific), Battery, Charger

Pad diameter	210 mm (8-1/4")
Abrasive Disc Size	225 mm (8-7/8")
No Load Speed (RPM)	1,000 - 1,800
Max Output	260 W
Vibration Level	Disc Sanding: 2.5 m/s ² or less
Vibration K Factor	Disc Sanding: 1.5 m/s ²
Sound Pressure Level	75 dB(A)
Noise K Factor	3 dB(A)
Dimensions (L x W x H)	1,100-1,520x259x273 mm (43-1/4"-59-3/4"x10-1/4"x10-3/4")
Net weight	4.5 - 5.7 kg (10.0 - 12.6 lbs.)

DSL800RTE
DSL800Z

DBS180

18V LXT BL 9 mm x 533 mm (3/8" x 21") Variable Speed Belt Sander

Cordless Belt Sander



- High power BL motor provides the same high performance as model 9032
- Movable LED job light; LED job light is manually angle-adjustable to match the angle of the sanding arm or the shape of the workpiece
- Adjustable sanding arm pivots up to 160° for compact storage (Model 9032: up to 90°)
- Electric brake minimizes down-time between sandings by quickly stopping the belt
- Variable speed control dial provides versatility for use on both wood and steel materials



LXT BL MOTOR



Sanding Belt, Grip, Grip Base, Battery, Charger

Belt Width	6 / 9 / 13 mm (1/4 / 3/8 / 1/2")
Belt Length	533 mm (21")
Belt Speed	600 - 1,700 /min
Dimensions (L x W x H)	w/ BL1830B / BL1840B / BL1850B / BL1860B : 500 x 96 x 116 mm (19-3/4 x 3-3/4 x 4-9/16") w/ Side Grip & BL1830B / BL1840B / BL1850B / BL1860B : 500 x 245 x 126 mm (19-3/4 x 9-5/8 x 5")
Net weight	1.8 - 2.1 kg (4.0 - 4.6 lbs.)

DBS180RTJ
DBS180Z

DSC191

18V LXT Li-Ion Cordless 20 mm (3/4") Steel Rod Cutter

440

Cordless Steel Rod Cutter



- Quick and effortless rebar cutting for maximum jobsite productivity and safety
- Ideal for cutting steel bars laid in concrete slab
- Up to 150 cuts of 20 mm rebar with a 6.0Ah LXT battery
- Cutting capacity range of 3 - 20 mm standard rebar
- 4-Way rotatable cutting blade provides up to 4,000 cuts before needing to be replaced



LXT



Wrench, Hex Wrench, Oil supply (country-specific)

Cutting Capacity	Dia.: 3 - 20 mm (1/8" - 3/4")
Cutting Speed (sec)	6.5
Vibration Level	Cutting Rebar: 2.5 m/s ² or less
Sound Pressure Level	80.5 dB(A)
Sound Power Level	90.1 dB(A)
Dimensions (L x W x H)	412x212x284 mm (16-1/5"x8-3/8"x11-1/8")
Net weight	11.1 - 11.2 kg (24.5 - 24.6 lbs.)

DSC191Z

DSC102

18V / 14.4V LXT BL Brushless Cordless Threaded Rod Cutter

Cordless Threaded Rod Cutter



- More Compact & High Productivity
- Cuts up to M10
- Compact motor section with overall length of 177 mm
- Excellent tool balance allows for operation with less wrist fatigue
- Compatible with both 18V and 14.4V LXT Li-Ion batteries



LXT

BL MOTOR



Cutter Blade, Hex socket head bolt, Blade Cover, Depth Gauge, Thumb screw, Hex Wrench

Capacity	Mild Steel: W3/8, M10, M8, M6 Stainless Steel: W3/8, M8, M6
Min. Cutting Length	20 mm (13/16")
Work Amount (pcs)	M8 (Mild Steel) w/BL1860B: 2,300 M8 (Stainless) w/BL1860B: 1,900
Vibration Level	Cutting Threaded Stainless Steel Rod (Rod Size W3/8): 2.5 m/s ² or less
Sound Pressure Level	71 dB(A)
Dimensions (L x W x H)	w/ BL1830B / BL1840B / BL1850B / BL1860B: 199x103x308 mm (7-7/8"x4-1/16"x12-1/8")
Net weight	2.8 - 3.2 kg (6.2 - 7.0 lbs.)

DSC102Z

DSC251

18V LXT Li-Ion Cordless Steel Rod Cutter

Cordless Steel Rod Cutter



- Ideal for edge cutting of threaded rods and rebars
- Fine edge cutting: Rebars can be cut at 3.5 mm from the corner of lattice for both vertically and horizontally; Threaded rods can be cut also at 3.5 mm from the ground/surface
- Less damage to the threaded rods and therefore nuts can be installed without removing burrs
- ADT (Automatic Torque Drive Technology) adjusts speed and torque during operation for optimum performance



LXT

BL MOTOR

ADT



Tipped Saw, Dust Bag, Side Grip, Hex Wrench

Blade Diameter	110 mm (4-5/16")
Cutting Capacity	Dia.: 10 - 25 mm (3/8" - 1")
No Load Speed (RPM)	2,200
Vibration Level	Cutting Rebar: 2.5 m/s ² or less
Sound Pressure Level	78 dB(A)
Dimensions (L x W x H)	471x137x139 mm (18-1/2"x5-3/8"x5-1/2")
Net weight	3.9 - 4.0 kg (8.7 - 8.8 lbs.)

DSC251RT
DSC251ZK

DPP200

18V LXT Li-Ion Cordless Hole Puncher

Cordless Hole Puncher

new



- Punches up to 20 mm holes through steel plate up to 8 mm thick
- Automatic punch return: After a punching cycle is completed, hydraulic pressure automatically pulls off the punch from workpiece and returns it to the initial position to enable efficient continuous hole punching
- Type of hole: Round hole / long hole



LXT

Not compatible with 2.0Ah, 1.5Ah batteries

Punch, Dice, Hex Wrench, Spanner, Bar for fastening nuts, Grip, Oil

Capacity	Steel: 20 mm (13/16") Stainless Steel: 20 mm (13/16")
Max Throat Depth	40 mm (1-9/16")
Dimensions (L x W x H)	w/ BL1830B / BL1840B / BL1850B / BL1860B: 417x127x315 mm (16-3/8"x5"x12-3/8")
Net weight	10.5 kg (23.2 lbs.)

DPP200ZK

DCS553

18V LXT BL ADT Cordless 150 mm (5-7/8") Metal Cutter, Electric Brake, Soft Start, Dual LED Lights

Cordless Metal Cutter



- Drastically Shortened Overall Length for Increased Maneuverability
- Built-in dust collection box for cleaner work environment
- Metal chip/dust can be thrown away by just opening the dust box cap
- Increased speed (4,200 RPM) provides more comfortable operation for light load application
- Cuts 51 mm (2") conduit in a single pass

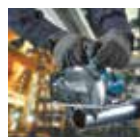

LXT

BL MOTOR

ADT

BRAKE

XPT



TCT Saw Blade, Hex Wrench, Safety Goggles, Guide Rule

Blade Diameter	150 mm (5-7/8")
Max Cutting Capacity	90°: 57.5 mm (2-1/4")
No Load Speed (RPM)	4,200
Vibration Level	Cutting Metal: 2.5 m/s ² or less
Sound Pressure Level	103 dB(A)
Sound Power Level	114 dB(A)
Dimensions (L x W x H)	267x186x250 mm (10-1/2"x7-3/8"x9-7/8")
Net weight	2.8 - 3.1 kg (6.1 - 6.8 lbs.)

DCS553RTJ
DCS553Z

DCS551

18V LXT BL Brushless Cordless 150 mm (5-7/8") Metal Cutter, Electric Brake, Soft Start, Dual LED Lights

Cordless Metal Cutter

- Drastically Shortened Overall Length for Increased Maneuverability
- Built-in dust collection box for cleaner work environment
- Metal chip/dust can be thrown away by just opening the dust box cap
- Increased speed (4,200 RPM) provides more comfortable operation for light load application
- Cuts 51 mm (2") conduit in a single pass



TCT Saw Blade, Hex Wrench, Safety

Blade Diameter	150 mm (5-7/8")
Max Cutting Capacity	90°: 57.5 mm (2-1/4")
No Load Speed (RPM)	3,900
Vibration Level	Cutting Metal: 2.5 m/s ² or less
Sound Pressure Level	78 dB(A)
Sound Power Level	N/A dB(A)
Dimensions (L x W x H)	332x158x231 mm (13-1/8"x6-1/4"x9-1/8")
Net weight	2.5 - 2.8 kg (5.5 - 6.2 lbs.)

DCS551Z

Cordless Rebar Tying Tool

DTR180

Easier and faster sequential rebar tying

Continuous actuation mode

Hold the trigger and pull the contact plate against rebars



Selectable 2-Modes



Single actuation
↑↓
Continuous actuation

Adjustable rebar tying strength

According to the condition of tying material, tying strength can be adjusted in 6 stages.



Applicable rebars :

D10 x D10 - (D13 x 2) x (D13 x 2)

Tying capacity (2 pcs of rebars)	Tying capacity (3 pcs of rebars)			Tying capacity (4 pcs of rebars)		
	D10 (#3)	D13 (#4)	D16 (#5)	D10 (#3) x D10 (#3)	D13 (#4) x D13 (#4)	D10 (#3) x D10 (#3) x D13 (#4)
D10(#3)	✓	✓	✓	✓	✓	✓
D13(#4)	✓	✓	✓	✓	✓	✓
D16(#5)	✓	✓	✓	✓	-	✓

(# means perimeter length: cm)

Compact and slim design

Enable to use in narrow areas

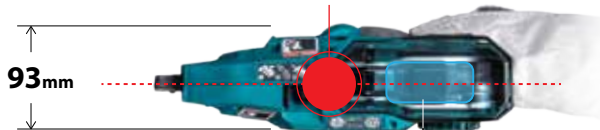

Easy to load with tie wire reel



Tie wire set



Tying times per 1 charge*
about
5,300times

1 Reel*
about
120times

* D10 x D10, 2pcs of rebars, Battery : BL1850B

Model No.	Per pkg.	Part No.
DTR180	50	199137-9

DTR180

18V LXT BL Brushless Cordless Rebar Tying Tool

Cordless Rebar Tying Tool



- Tying Rebars Automatically
- Tying rebars can be done automatically in a various range of applications such as building concrete foundations
- Operable by only one hand, allowing the other hand to be free to adjust the position of rebar
- Continuous actuation mode for efficient continuous tying
- Users can tie rebars by only pulling contact arm against rebars if they continuously hold the trigger



Hex Wrench, Hook

Tie Wire	0.8 mm
Applicable Rebars	D10 x D10 - (D13 x 2) x (D13 x 2)
Vibration Level	2.5 m/s ² or less
Sound Pressure Level	78 dB(A)
Dimensions (L x W x H)	w/ BL1815N / BL1820B: 304x93x301 mm (12"x3-2/3"x11-7/8") w/ BL1830B / BL1840B / BL1850B / BL1860B: 304x93x318 mm (12"x3-2/3"x12-1/2")
Net weight	2.3 - 2.6 kg (5.1 - 5.7 lbs.)

DTR180Z

DJS161

18V LXT Li-Ion Cordless 1.6 mm Straight Shear

430

Cordless Straight Shear



- Straight design provides more control and high maneuverability for easy cutting operation
- Compact and lightweight design for easy handling and high maneuverability
- High cutting capacity: cuts up to 1.6 mm thick mild steel sheet
- Anti-restart function with warning lamp for safety
- Warning lamp for low battery capacity



Hex Wrench, Thickness Gauge

Capacity	Steel up to 400 N/mm ² : 1.6 mm Steel up to 600 N/mm ² : 1.2 mm Aluminum up to 200 N/mm ² : 2.5 mm
Strokes Per Minute (SPM)	4,300
Dimensions (L x W x H)	362x78x118 mm (14-1/4"x3-1/16"x4-5/8")
Net weight	1.8 - 2.2 kg (4.1 - 4.8 lbs.)

DJS161Z

DPB183

18V LXT BL Cordless Portable Band Saw

Cordless Portable Band Saw

new



- BL motor delivers 3.2 m/s (630 ft./min.) blade speed for faster cutting
- BL motor eliminates carbon brushes, enabling the BL motor to run cooler and more efficiently for longer life
- BL motor is electronically controlled to optimize battery energy use for longer run time per charge
- BL motor efficiently uses energy to match torque and RPM to the changing demands of the application
- Constant speed control minimizes the reduction in blade speed to provide stable cutting



Band Saw Blade, Hex Wrench, Hook (country-specific), Grip (country-specific), Battery, Charger

Capacity	Round: 66 mm (2-5/8") Square: 66 x 66 mm (2-5/8 x 2-5/8")
Vibration Level	Cutting Metal: 2.5 m/s ² or less
Vibration K Factor	Cutting Metal: 1.5 m/s ²
Sound Pressure Level	80 dB(A)
Dimensions (L x W x H)	392 x 174 x 242 mm (15-1/2 x 6-7/8 x 9-1/2")
Net weight	3.6 - 3.9 kg (7.9 - 8.6 lbs.)

DPB183RTE
DPB183Z

DPB182

18V LXT Li-Ion Cordless Portable Band Saw

Cordless Portable Band Saw



- Stable Cutting with Highly Rigid Aluminum Structure
- Aluminum housing/frame improves rigidity and prevents blade from coming off
- Prevents blade slipping on wheel by raising tension force
- Easy blade track adjustment simply by turning the screw
- Delivers 3.2 m/s (630 ft./min.) blade speed for faster cutting
- 64 mm (2-1/2") cutting capacity is ideal for cutting conduit, Unistrut®, copper pipe, threaded rod, angle iron and channel
- Compact and lightweight design for convenient operation



Band Saw Blade, Wheel Cover (country-specific), Hook (country-specific), Hex Wrench, Battery, Charger

Capacity	Round: 64 mm (2-1/2") Rectangular: 64x64 mm (2-1/2"x2-1/2")
Vibration Level	Cutting Metal: 2.5 m/s ² or less
Vibration K Factor	Cutting Metal: 1.5 m/s ²
Sound Pressure Level	79 dB(A)
Dimensions (L x W x H)	477x197x229 mm (18-3/4"x7-3/4"x9")
Net weight	3.8 - 4.1 kg (8.3 - 9.0 lbs.)

DPB182RTE
DPB182Z

Easy installation / removal of blade

Redesigned structure of wheel cover* and frame (lowered aluminum portion than wheel) for easy installation / removal of blade when the wheel cover is open.

* This model comes with wheel cover for all specifications.



Constant speed control

minimizes the reduction in blade speed to provide stable cutting.

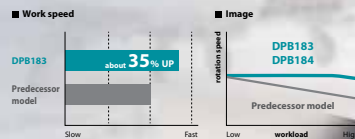

Test material: Carbon steel pipe of 48.6mm diameter with thickness of 3.7mm





Auto-start Wireless System

Switch on the tool, and Vacuum cleaner is activated

It has been impossible, but now Vacuum cleaner can be automatically activated by Cordless tools with our newly developed wireless system.



AWS connects to power tool with Bluetooth

The Bluetooth® word mark and logos are registered trademarks owned by the Bluetooth SIG, Inc. and any use of such marks by Makita is under license. Other trademarks and trade names are those of their respective owners.



Automatic torque Drive Technology automatically changes the cutting speed according to load conditions for an optimum operation

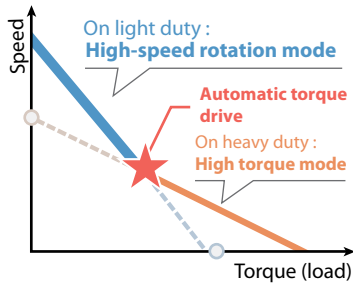

DGA419, DGA469, DGA519 only

Just one click to attach the accessories and easy removal just simply pull the lever



Active Feedback sensing Technology Shuts down the tool to protect the user, if the rotation speed suddenly slows down.

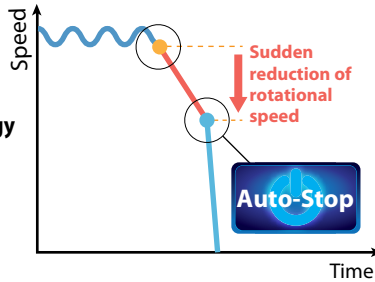

delivers optimal performance and efficiency even for heavy-duty applications



Electric brake maximizes productivity and increases safety for operator

Product Comparison List

Model No.			No load speed (rpm)	Switch	AWS	BL motor	AFT	ADT	Brake	Anti-restart function	X-Lock
100mm	115mm	125mm									
DGA414	DGA464	DGA514	3,000 - 8,500	Slide	•	•	•	•	•	•	
DGA413	DGA463	DGA513	3,000 - 8,500	Slide		•	•	•	•	•	
DGA412	DGA462	DGA512	3,000 - 8,500	Slide	•	•	•	•	•	•	
DGA411	DGA461	DGA511	3,000 - 8,500	Slide		•	•	•	•	•	
DGA406	DGA456	DGA506	8,500	Slide		•	•	•	•	•	
DGA404	DGA454	DGA504	8,500	Slide		•	•	•	•	•	
DGA402	DGA452		11,000	Slide						•	
DGA417	DGA467	DGA517	3,000 - 8,500	Paddle		•	•	•	•	•	
DGA419	DGA469	DGA519	3,000 - 8,500	Paddle		•			•	•	•
DGA418	DGA468	DGA518	3,000 - 8,500	Paddle	•	•	•	•	•	•	
DGA405	DGA455	DGA505	8,500	Paddle		•	•	•	•	•	
DGA408	DGA458	DGA508	8,500	Paddle		•	•	•	•	•	

Cordless Angle Grinder

18V LXT BL Cordless Angle Grinder, Variable Speed, Anti-Restart Function, Electric Brake, Slide Switch Lock-On



	DGA413	DGA513
Wheel Diameter	100 mm (4")	125 mm (5")
No Load Speed (RPM)	3,000 - 8,500	3,000 - 8,500
Vibration Level	Surface Grinding w/ Anti-Vibration Side Grip: 4.0 m/s ² Disc Sanding w/ Anti-Vibration Side Grip: 2.5 m/s ² or less	Surface Grinding w/ Anti-Vibration Side Grip: 6.0 m/s ² Disc Sanding w/ Anti-Vibration Side Grip: 2.5 m/s ² or less
Sound Pressure Level	80 dB(A)	79 dB(A)
Dimensions (L x W x H)	w/ BL1815N / BL1820B: 368x117x147 mm (14-1/2"x4-5/8"x3-3/4") w/ BL1830B / BL1840B / BL1850B / BL1860B: 382x117x147 mm (15"x4-5/8"x3-3/4")	w/ BL1815N / BL1820B: 368x140x151 mm (14-1/2"x5-1/2"x5-15/16") w/ BL1830B / BL1840B / BL1850B / BL1860B: 382x140x151 mm (15"x5-1/2"x5-15/16")
Net weight	2.2 - 2.8 kg (4.9 - 6.2 lbs.)	2.4 - 3.0 kg (5.2 - 6.7 lbs.)

Grinding Wheel, Wheel Cover, Side Grip, Lock Nut Wrench

DGA413RTE
DGA413ZDGA513RTE
DGA513Z

Cordless Angle Grinder

18V LXT BL Cordless Angle Grinder, Variable Speed, Anti-Restart Function, Slide Switch Lock-On



	DGA411	DGA511
Wheel Diameter	100 mm (4")	125 mm (5")
No Load Speed (RPM)	3,000 - 8,500	3,000 - 8,500
Vibration Level	Surface Grinding w/ Anti-Vibration Side Grip: 4.0 m/s ² Disc Sanding w/ Anti-Vibration Side Grip: 2.5 m/s ² or less	Surface Grinding w/ Anti-Vibration Side Grip: 6.0 m/s ² Disc Sanding w/ Anti-Vibration Side Grip: 2.5 m/s ² or less
Sound Pressure Level	80 dB(A)	79 dB(A)
Dimensions (L x W x H)	w/ BL1815N / BL1820B: 368x117x140 mm (14-1/2"x4-5/8"x5-1/2") w/ BL1830B / BL1840B / BL1850B / BL1860B: 382x117x140 mm (15"x4-5/8"x5-1/2")	w/ BL1815N / BL1820B: 368x140x145 mm (14-1/2"x5-1/2"x5-3/4") w/ BL1830B / BL1840B / BL1850B / BL1860B: 382x140x145 mm (15"x5-1/2"x5-3/4")
Net weight	2.2 - 2.8 kg (4.8 - 6.1 lbs.)	2.3 - 3.0 kg (5.1 - 6.6 lbs.)

Grinding Wheel, Wheel Cover, Side Grip, Lock Nut Wrench

DGA411RTE
DGA411ZDGA511RTE
DGA511Z

Cordless Angle Grinder

18V LXT BL Cordless Angle Grinder, Variable Speed, Anti-Restart Function, Electric Brake, Paddle Switch



	DGA417	DGA517
Wheel Diameter	100 mm (4")	125 mm (5")
No Load Speed (RPM)	3,000 - 8,500	3,000 - 8,500
Vibration Level	Surface Grinding w/ Anti-Vibration Side Grip: 4.5 m/s ² Disc Sanding w/ Anti-Vibration Side Grip: 2.5 m/s ² or less	Surface Grinding w/ Anti-Vibration Side Grip: 5.5 m/s ² Disc Sanding w/ Anti-Vibration Side Grip: 2.5 m/s ² or less
Sound Pressure Level	80 dB(A)	79 dB(A)
Dimensions (L x W x H)	w/ BL1815N / BL1820B: 368x117x146 mm (14-1/2"x4-5/8"x3-3/4") w/ BL1830B / BL1840B / BL1850B / BL1860B: 382x117x146 mm (15"x4-5/8"x3-3/4")	w/ BL1815N / BL1820B: 368x140x151 mm (14-1/2"x5-1/2"x6") w/ BL1830B / BL1840B / BL1850B / BL1860B: 382x140x151 mm (15"x5-1/2"x6")
Net weight	2.2 - 2.9 kg (4.9 - 6.3 lbs.)	2.4 - 3.1 kg (5.2 - 6.7 lbs.)

Grinding Wheel, Wheel Cover, Side Grip, Lock Nut Wrench

DGA417RTE
DGA417ZDGA517RTE
DGA517Z

Cordless Angle Grinder

18V LXT BL Cordless Angle Grinder, Variable Speed, Anti-Restart Function, Electric Brake, Paddle Switch, X-LOCK



	DGA419	DGA519
Wheel Diameter	100 mm (4")	125 mm (5")
No Load Speed (RPM)	3,000 - 8,500	3,000 - 8,500
Dimensions (L x W x H)	w/ BL1815N / BL1820B: 382x117x147 mm (15"x4-5/8"x3-3/4") w/ BL1830B / BL1840B / BL1850B / BL1860B: 396x117x147 mm (15-1/2"x4-5/8"x3-3/4")	w/ BL1815N / BL1820B: 382x117x147 mm (15"x4-5/8"x3-3/4") w/ BL1830B / BL1840B / BL1850B / BL1860B: 396x117x147 mm (15-1/2"x4-5/8"x3-3/4")
Net weight	2.5 - 3.1 kg (5.5 - 6.7 lbs.)	2.6 - 3.1 kg (5.6 - 6.9 lbs.)

Grinding Wheel, Wheel Cover, Side Grip, Lock Nut Wrench, Battery, Charger

DGA419RTJ
DGA419ZDGA519RTJ
DGA519Z

DTM51

Cordless Multi Tool

18V LXT Li-Ion Cordless Toolless Multi Tool



- Toolless clamp system for fast accessory installation
- Variable speed control dial (6,000-20,000 OPM) enables user to match the speed to the application
- 3.2" Oscillation angle engineered for faster, more aggressive cutting and sanding
- 12 Angle settings at every 30° from 0° to 360°
- Easy-to-operate slide switch increases productivity and allows for continuous use



Oscillating multi tool accessories, Dust Attachment (country-specific), Tool Box (country-specific)

Oscillations Per Minute (OPM)	6,000 - 20,000
Oscillation Angle	Left / Right / Total: 1.6° / 1.6° / 3.2°
Vibration Level	Sanding: 3.0 m/s ² Plunge Saw Blade: 7.0 m/s ² Segmental Saw Blade: 4.5 m/s ² Scraping: 5.5 m/s ²
Sound Pressure Level	Sanding: 77 dB(A) Plunge Saw Blade: 81 dB(A) Segmental Saw Blade: 76 dB(A) Scraping: 80 dB(A)
Sound Power Level	Plunge Saw Blade: 92 dB(A) Scraping: 91 dB(A)
Dimensions (L x W x H)	340x80x122 mm (13-3/8"x3-1/8"x4-13/16")
Net weight	2.0 - 2.4 kg (4.4 - 5.3 lbs.)

DTM51RTE

DTM51RFE

DHS661 / DHS660

Cordless Circular Saw

18V LXT BL ADT Cordless 165 mm (6-1/2") Circular Saw, Electric Brake, Soft Start, Dual LED Lights



- Compact and Lightweight Design for Better Maneuverability
- Indication lamp using ADT (Automatic torque Drive Technology)
- High-efficiency BL motor provides higher power and more work amount
- Smooth cutting at high rotational speed of 5,000 RPM
- Auto-start Wireless System (AWS) connects to compatible vacuum cleaners with Bluetooth (DHS661)



TCT Saw Blade, Hex Wrench, Rip Fence (Guide Rule), Dust Nozzle (country-specific)

Blade Diameter	165 mm (6-1/2")
Hole Diameter	15.88 / 20 mm (5/8" / 13/16")
Max Cutting Capacity	90°: 57 mm (2-1/4") 45°: 41 mm (1-5/8") 50°: 37 mm (1-7/16")
No Load Speed (RPM)	5,000
Vibration Level	Cutting Wood: 2.5 m/s ² or less
Sound Pressure Level	93 dB(A)
Sound Power Level	104 dB(A)
Dimensions (L x W x H)	270x186x250 mm (10-5/8"x7-3/8"x9-7/8")
Net weight	2.9 - 3.2 kg (6.4 - 7.1 lbs.)
DHS661RFJ DHS661Z	DHS660RFJ DHS660Z

DHS475

Cordless Circular Saw

18V LXT BL AWS Cordless 125 mm (4-7/8") Circular Saw, Electric Brake, Soft Start, Dual LED Lights



- High-Efficiency BL Motor Provides Higher Power and More Work Amount
- Easy cutting depth adjustment; The angular guide not integrated with the base prevents the distortion of the depth guide, which occurs in the process of parallel adjustment of the base, allowing for easy cutting depth adjustment
- Newly designed sub base; The difference in bottom surface level between the base and the sub base has been drastically reduced
- Compact and lightweight design for better maneuverability
- Smooth cutting at high rotational speed of 5,400 RPM



TCT Saw Blade, Hex Wrench, Battery, Charger

Blade Diameter	125 mm (4-7/8")
Max Cutting Capacity	90°: 47 mm (N/A) 45°: 30 mm (N/A) -15°: 20 mm (N/A)
No Load Speed (RPM)	5,400
Dimensions (L x W x H)	256x183x246 mm (10-1/8"x7-1/4"x9-11/16")
Net weight	2.4 - 2.8 kg (5.4 - 6.1 lbs.)
DHS475RTJ DHS475Z	

DLS600

Cordless Compound Miter Saw

18V LXT BL ADT Cordless 165 mm (6-1/2") Compound Miter Saw with LED Light



- Suitable for Cutting Baseboard and Ceiling Trim, etc
- High accuracy + Lightweight + Cordless
- Compact and lightweight body provides excellent portability
- Powerful BL Motor delivers 5,000 RPM for fast cutting
- Automatic torque Drive Technology (ADT) adjusts speed and torque during operation for optimum performance



TCT Saw Blade, Dust Bag, Vertical Vise, Hex Wrench, Triangular Rule

Blade Diameter	165 mm (6-1/2")
Miter Angle	52° L / 52° R
Bevel Angle	46° L / 46° R
Max Cutting Capacity	90° Miter: 46 x 92 mm (1-13/16" x 3-5/8") 45° Miter, L/R: 46 x 65 mm (1-13/16" x 2-9/16")
No Load Speed (RPM)	5,000
Sound Pressure Level	90 dB(A)
Sound Power Level	97 dB(A)
Vibration Level	2.5 m/s ² or less
Dimensions (L x W x H)	340x400x440 mm (13-3/8"x15-3/4"x17-1/4")
Net weight	6.3 - 6.6 kg (13.9 - 14.6 lbs.)
DLS600RTE DLS600Z	

DJR186

Cordless Recipro Saw

18V LXT Li-Ion Cordless Recipro Saw



- Newly designed vertical crank mechanism minimizes blade deflection and reduces vibration to machine
- Higher cutting speed (Max 2,800 SPM) and modified stroke length (32 mm) provide higher cutting efficiency
- Higher durability thanks to More durable mechanism to hold slider and More rigid shoe
- Toolless blade change; Redesign of blade clamp makes it easier to remove a blade
- Ergonomically designed handle with elastomer for more comfortable and controlled operation



Recipro Saw Blades

Length of Stroke	32 mm (1-1/4")
Strokes Per Minute (SPM)	High / Low: 0 - 3,000 / 0 - 2,300
Capacity	Pipe : 130 mm (5-1/8") Wood: 255 mm (10")
Vibration Level	Cutting Boards: 16.5 m/s ² Cutting Wooden Beams: 15.5 m/s ²
Sound Pressure Level	84 dB(A)
Sound Power Level	95 dB(A)
Dimensions (L x W x H)	439x83x231 mm (17-1/4"x3-1/4"x9-1/8")
Net weight	3.4 - 3.8 kg (7.6 - 8.3 lbs.)
DJR186RFE DJR186Z	

DJR188

Cordless Recipro Saw

18V LXT BL Brushless Cordless Recipro Saw



- Compact and Lightweight for Increased Maneuverability
- Ergonomically designed handle with elastomer for more comfortable and controlled operation
- Ergonomically designed handle fits your hand well, even during difficult cutting applications such as overhead application, cutting with the saw upside down, etc
- Soft grip provides more comfort and control
- High cutting speed (Max 3,000 SPM) and stroke length (20 mm) provide higher cutting efficiency



Recipro Saw Blades

Length of Stroke	20 mm (13/16")
Strokes Per Minute (SPM)	0 - 3,000
Capacity	Pipe : 130 mm (5-1/8") Wood: 255 mm (10")
Vibration Level	Cutting Boards: 15.5 m/s ² Cutting Wooden Beams: 15.0 m/s ²
Sound Pressure Level	83 dB(A)
Sound Power Level	94 dB(A)
Dimensions (L x W x H)	w/ BL1815N / BL1820B: 316x81x203 mm (12-1/2"x3-3/16"x8") w/ BL1830B / BL1840B / BL1850B / BL1860B: 316x81x220 mm (12-1/2"x3-3/16"x8-5/8")
Net weight	2.6 - 2.9 kg (5.7 - 6.4 lbs.)
DJR188RFJ	DJR188Z

DSD180

Cordless Drywall Saw



- Ideal for cutting holes in drywalls when setting ceiling lights, air vents etc
- More suitable for straight cuts compared with general cut-out tools
- Dust box designed to catch dust in overhead applications for comfortable work
- Excellent tool balance allows easy overhead application
- Easy straight cutting achieved by the blade shape and cutting system



LXT



Blade, Blade Cover, Base Cover, Hex Wrench

Strokes Per Minute (SPM)	0 - 6,000
Length of Stroke	6 mm (1/4")
Capacity	Drywall: 30 mm (1-3/16") Wood: 15 mm (9/16")
Vibration Level	Cutting Drywall (thickness 30mm): 2.5 m/s ² Cutting Chip Board (thickness 15mm): 5.0 m/s ²
Sound Pressure Level	79 dB(A)
Dimensions (L x W x H)	263x79x291 mm (10-3/8"x3-1/8"x11-3/8")
Net weight	1.7 - 2.0 kg (3.8 - 4.5 lbs.)

DSD180Z

DKP181

Cordless Planer



new

- BL motor delivers high power
- Auto-start Wireless System (AWS) connects to vacuum cleaner with Bluetooth
- Automatic torque Drive Technology (ADT) adjusts cutting speed and torque during cut for optimum performance
- Both-side chip ejection
- Shiplapping : 25 mm (1")

LXT BL MOTOR AWS ADT



Planer Blade, Blade Gauge, Guide Rule, Socket Wrench, Dust Nozzle

Planing Width	82 mm (3-1/4")
Planing Depth	3 mm (1/8")
No Load Speed (RPM)	12,000
Dimensions (L x W x H)	366x156x166 mm (14-3/8"x6-1/8"x6-1/2")
Net weight	3.3 - 3.6 kg (7.3 - 7.9 lbs.)

Shiplapping : 25 mm (1")

DKP181RTJ

DKP181Z

DCO181

Cordless Cut-Out Tool



new

- High power delivered by BL motor
- Twin LED job light with afterglow function for more visibility
- Soft start suppresses start-up reaction for more control and better accuracy
- Shoe plate can be used as a wrench for bit replacement
- Electric brake for maximum productivity and increased operator safety



LXT BL MOTOR AWS ADT



Drywall Guide Bit, Collet Cone, Dust Collection Cover, Wrench, Battery, Charger

Collet Capacity	3.18 or 6.35 mm (1/8 or 1/4")
No Load Speed (RPM)	32,000
Circumference of Grip Portion	210 mm (8-1/4")
Dimensions (L x W x H)	w/ BL1830B / BL1840B / BL1850B / BL1860B : 311 x 79 x 117 mm (12-1/4 x 3-1/8 x 4-5/8")
Net weight	1.4 - 1.7 kg (3.1 - 3.7 lbs.)

Shiplapping : 25 mm (1")

DCO181RTJ

DCO181Z

High power delivered by BL motor

Less vibration

0.66 m/s²

Due to the spindle integrated with the motor shaft.

BL MOTOR

Cordless Trimmer

DRT50 6 mm (1/4"), 8 mm (3/8")

Available in various combinations for added versatility



with Trimmer base



Enlarged opening section of base assembly for excellent bit visibility while maintaining durability.



with Plunge base (option)



Ergonomically contoured knob style handles



Optional Fine adjusting straight guide can be used.



with Tilt base (option)



Enlarged opening section of base assembly for excellent bit visibility.



with Offset base (option)



Able to cut close to a wall or corner-18.5mm at closest

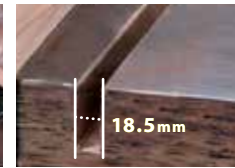

DRT50

Cordless Trimmer

18V LXT BL Brushless Cordless 6 mm (1/4"), 8 mm (3/8") Variable Speed Trimmer with Dual LED Lights



- Up to 10% Faster Trimming than Corded Model RT0700C
- BL motor delivers the power and performance for corded demands
- Cordless for easy maneuverability
- Aluminum base for higher durability and accuracy
- Plastic cover plate protects workpiece from scratches
- 4 Different base assemblies for added versatility
- BL motor delivers 30,000 RPM for fast trimming
- BL motor with high power to weight and size ratio



Collet Cone, Trimmer Base Assembly, Straight Guide Assembly, Templet Guide, Wrench x2, Trimmer Guide, Battery, Charger

No Load Speed (RPM)	10,000 - 30,000
Plunge Capacity	w/ Trimmer Base: 0 - 40 mm (0" - 1-9/16") w/ Plunge Base: 0 - 35 mm (0" - 1-3/8")
Vibration Level	Rotation w/o Load: 2.5 m/s ² or less Cutting Grooves in MDF: 4.5 m/s ²
Sound Pressure Level	78 dB(A)
Dimensions (L x W x H)	w/ BL1815N / BL1820B: 134x89x208 mm (5-1/4"x3-1/2"x8-1/8") w/ BL1830B / BL1840B / BL1850B / BL1860B: 134x89x226 mm (5-1/4"x3-1/2"x8-7/8")
Net weight	1.8 - 2.1 kg (3.9 - 4.6 lbs.)

DRT50RFJX9
DRT50RFJ

DRT50SFX8
DRT50Z



Base for DRT50 & RT0700C

Able to meet a wide range of needs with the Motor unit and the following various attachments

item.	Per pkg.	Part No.
Trimmer base assembly	1	196612-6
	12	196614-2
Trimmer base plate	1	454842-8
Grip attachment set	1	196924-7
	4	199090-9
Trimmer base assembly clear	1	199092-5
	4	199090-9
Plunge base assembly	1	195563-0
	4	195815-9

item.	Per pkg.	Part No.
Plunge base plate	1	450819-1
Tilt base assembly	1	195561-4
	12	195813-3
Tilt base plate	1	413150-6
Offset base assembly Able to trim close to wall and tight corners with a bit set in offset position. Distance 18.5mm from the edge to the center of bit	1	196922-1
	4	196921-3
Offset base plate	1	413148-3
Grip attachment Offset base plate (P/N:413148-3) and countersunk head screw M4x10 are also necessary.	1	318685-1

DVP180

Cordless Vacuum Pump



Not compatible with
2.0Ah, 1.5Ah batteries

18V LXT Li-Ion Cordless Vacuum Pump

- Cordless vacuum pump for air purge during installation of room air conditioner
- Removes all air from refrigerant tubing to create a vacuum environment before the tubing is charged with refrigerant gas
- Long run time of 50 minutes with a fully charged BL1850B
- Compression type: Oil rotary type (vane type), Single stage
- Easy to carry with a compact and lightweight body



LXT

Vacuum Pump Oil, Adapter

Flow rate	50 L/min
Ultimate vacuum	20 Pa (150 microns)
Motor speed	3,840 min ⁻¹
Oil Tank Capacity	115 mL
Inlet port	5/16"
Dimensions (L x W x H)	265x93x175 mm (10-3/8"x3-5/8"x6-7/8")
Net weight	3.5 kg

Net weight: With BL1830/ BL1840/ BL1850 and Oil

DVP180RT
DVP180Z

DCG180

Cordless Caulking Gun



18V LXT Li-Ion Cordless Caulking Gun

- Delivers an industry-leading 5,000 N (1,100 lbs) of dispensing force to work with the highest viscosity adhesives and sealants
- 5 Speed dial optimizes flow rate from 0 - 28 mm/sec. (0 - 66 IPM)
- Variable speed trigger allows user to match the speed to the application
- 360° Rotatable cartridge holder fits 800 ml, 600 ml and 300 ml cartridges
- Drip-reduction feature automatically relieves pressure on the material when trigger is released to prevent unintentional dispensing



LXT

Holder, Holder Joint, Piston, Rubber Ring, Nozzle

Max Dispensing Force	5,000 N (1,100 lbs)
No load speed	0 - 28 mm/sec. (0 - 66 in/min.)
Holder Size	300, 600, 800 mL
Sound Pressure Level	70 dB(A) or less
Vibration Level	Operation w/o Load: 2.5 m/s ² or less
Dimensions (L x W x H)	404x108x281 mm (15-7/8"x4-1/4"x11-1/8")
Net weight	2.1 - 3.0 kg (4.7 - 6.6 lbs.)

DCG180ZB

DRV250 / DRV150

Cordless Rivet Gun



18V LXT BL Brushless Cordless Rivet Gun

- Jaw case designed to enable tight space operation
- The short center height allows for tight space operation such as close-to-wall riveting
- Compatible with various sizes of blind rivets
- A wide range of nose pieces and jaw pushers allow for tightening various sizes of blind rivets
- Compatible rivet diameter: 2.4 - 6.4mm(DRV250), 2.4 - 4.8mm(DRV150)



LXT BL MOTOR XPT



Hook, Grease, Accessory Set, Battery, Charger

Pulling Force	DRV250: 20 kN (4,500 lbs.) / DRV150: 10 kN (2,200 lbs.)
Stroke	DRV250: 30 mm (1-3/16") / DRV150: 25 mm (1")
Rivet Diameter Range	DRV250: 2.4 - 6.4 mm (3/32" - 1/4") DRV150: 2.4 - 4.8 mm (3/32" - 3/16")
Vibration Level	Installing Blind Rivet: 2.5 m/s ² or less
Sound Pressure Level	DRV250: 74 dB(A) / DRV150: 75 dB(A)
Dimensions (L x W x H)	w/ BL1815N / BL1820B: DRV250: 323x80x270 mm (12-3/4"x3-1/8"x10-5/8") DRV150: 313x80x270 mm (12-3/8"x3-1/8"x10-5/8") w/ BL1830B / BL1840B / BL1850B / BL1860B: DRV250: 323x80x287 mm (12-3/4"x3-1/8"x11-1/4") DRV150: 313x80x287 mm (12-3/8"x3-1/8"x11-1/4")
Net weight	DRV250: 2.1 - 2.4 kg (4.6 - 5.3 lbs.) DRV150: 1.9 - 2.2 kg (4.2 - 4.9 lbs.)

DRV250RFE
DRV250ZDRV150RFE
DRV150Z

DPT353

Cordless Pin Nailer



18V LXT Li-Ion Cordless 23 Ga 35 mm (1-3/8") Pin Nailer

- Low Reaction Force Mechanism Enables Easier Long Pin Nailing and High-Quality Finish
- Easy-to-see slim nose tip allows quick and easy access to a desired fastening point
- Nails can be fired in the groove of baseboard
- Shoots 6,400 nails on a single full BL1860B charge
- Contact arm mechanism enables "continuous nailing" and "drag nailing"



LXT



Nose Adapter, Safety Goggles, Belt Clip, Hex Wrench

Capacity	Length: 15 - 50 mm (5/8" - 2") Gauge: 18 Ga
	110 w/ BL1840B: 1,300
	1.5 - 2
Magazine Capacity	28 mm (1-1/8")
Vibration Level	2.5 m/s ² or less
Sound Pressure Level	79 dB(A)
Dimensions (L x W x H)	294x97x318 mm (11-5/8"x3-13/16"x12-1/2")
Net weight	3.2 - 3.5 kg (7.05 - 7.72 lbs.)

DPT353RFE
DPT353Z

DPO500

Cordless Random Orbit Polisher



18V LXT BL Brushless Cordless 125 mm (5") Random Orbit Polisher

- BL Motor Delivers 0-6,800 OPM, 0-13,600 SPM and 0-780 RPM for Faster Polishing
- BL motor is electronically controlled to optimize battery energy use for longer run time per charge
- BL motor eliminates carbon brushes, enabling the BL motor to run cooler and more efficiently for longer life
- Selectable two rotation mode: normal mode for rough polishing & finishing mode for fine polishing



LXT



Side Grip (country-specific), Pad (country-specific), Hex Wrench

Pad Size	125 mm (5")
Orbits Per Minute (OPM)	Normal mode: 0 - 6,800 Finishing mode: 0 - 5,200
Vibration Level	Polishing: 9.5 m/s ²
Vibration K Factor	Polishing: 1.5 m/s ²
Sound Pressure Level	82 dB(A)
Sound Power Level	93 dB(A)
Noise K Factor	3 dB(A)
Dimensions (L x W x H)	530x123x134 mm (20-7/8"x4-7/8"x5-1/4")
Net weight	3.1 - 3.6 kg (6.9 - 7.9 lbs.)

DPO500RTE
DPO500Z

DUT130

18V LXT BL Brushless 165 mm (6-1/2") Variable 2-Speed Mixer

Cordless Mixer

- BL Motor Delivers Max 1,300 RPM
- BL motor is electronically controlled to optimize battery energy use for longer run time per charge
- BL motor eliminates carbon brushes, enabling the BL motor to run cooler and more efficiently for longer life
- Variable 2-speed transmission (0-350 & 0-1,300 RPM) for a wide range of applications



LXT



Mixing Blade, Shaft, Shaft Holder (country-specific), Grip, Front Cover, Wrenches, Battery, Charger

Blade Diameter	165 mm (6-1/2")
No Load Speed (RPM)	High / Low: 0 - 1,300 / 0 - 350
Max Output	650 W
Vibration Level	Operation w/o Load: 2.5 m/s ² or less
Vibration K Factor	Operation w/o Load: 1.5 m/s ²
Sound Pressure Level	74 dB(A)
Noise K Factor	3 dB(A)
Dimensions (L x W x H)	w/ Mixing Blade: 916x89x231 mm (36"x3-1/2"x9-1/8") w/o Mixing Blade: 320x89x231 mm (12-5/8"x3-1/2"x9-1/8")
Net weight	2.5 - 2.8 kg (5.6 - 6.3 lbs.)

DUT130RTE
DUT130Z

Cordless Portable Vacuum Cleaner

DVC750L

Compact, portable and easy-to-use



Wet and dry



2 functions in 1 machine convertible into a blower

Continuous use
35 min
mode : High
with BL1860B



Nozzle can be stored



Easy disposal

DVC750L

18V LXT BL Brushless Cordless 7.5 L HEPA Portable Vacuum Cleaner

Cordless Portable Vacuum Cleaner

- Compact, portable and easy-to-use
- BL motor allows 1.6 m³/min of Max air flow /6.7 kPa of Max sealed suction/ 50 W of Suction power and long run time to go together
- HEPA Filter is used to capture very fine particles effectively
- Wet and dry
- 7.5L Large dust bag capacity enables continuous cleaning work



LXT BL MOTOR XPT



Hose, Floor Nozzle, Sash Nozzle

Capacity	Dust / Water : 7.5 / 4.5 L
Continuous Use (min.)	w/ BL1860B (High) : 35 w/ BL1860B (Low) : 70
Max Air Flow	1.6 m ³ /min
Max Sealed Suction	6.7 kPa
Suction Power	High / Low : 50 / 25 W
Dimensions (L x W x H)	418x251x278 mm (16-1/2"x9-7/8"x11")
Net weight	4.3 - 4.6 kg (9.4 - 10.1 lbs.)

DVC750LZ

DVC750LZX1

DCL184

Cordless Cleaner

new**18V LXT Li-Ion Cordless 3-Speed Cleaner**

- Higher suction power and longer continuous run time
- Optimum housing design for car interior cleaning
- Comes with a variety of special nozzles optimum for cleaning car interior
- Also accepts the nozzles for our existing cordless cleaners
- Blower nozzle complete converts to a blower for added versatility
- Cleaning can be done without nozzle by using beveled end straight pipe as a nozzle
- Low noise achieved by noise absorbing sponge attached inside the housing, noise level is the same as CL121D while increasing suction power

**LXT**

Seat Nozzle, Mat Nozzle, Rubber Nozzle, Soft Brush, Blower Attachment, Dust Bag, Paper Dust Bag, Shoulder Belt, Battery, Charger

Capacity	Cloth Dust Bag / Paper Dust Bag: 500 / 330 mL
Continuous Use (min.)	Max / High / Normal: 20 / 30 / 80
Max Air Flow	1.4 m ³ /min
Max Sealed Suction (water column)	5.4 kPa (550 mmH ₂ O)
Suction Power	Max / High / Normal: 38 / 23 / 5 W
Max Air Flow	Blowing: 0.4 m ³ /min
Max Air Velocity	Blowing: 100 m/s
Vibration Level	0.4 m/s ²
Noise Level	Max / High / Normal: 68 / 65 / 58 dB(A)
Dimensions (L x W x H)	w/ BL1830B / BL1840B / BL1850B / BL1860B: 365 x 138 x 202 mm (14-3/8 x 5-7/16 x 8")
Net weight	1.8 - 2.2 kg (4.0 - 4.9 lbs.)

DCL184RF
DCL184Z**DCL180**

Cordless Cleaner

**18V LXT Li-Ion Cordless Cleaner**

- Strong suction power for fast cleaning with more run time
- Up to 20 min. of continuous use from a single fully charged BL1830B
- Redesigned floor nozzle for improved maneuverability and debris collection
- Bagless 2-stage cloth filtration system allows for easier cleaning and quicker debris disposal
- Increased storage capacity for longer time between waste disposal
- Compact and ergonomic design at only 999 mm long
- Lightweight for reduced operator fatigue

**LXT**

Floor Nozzle, Sash Nozzle, Sash Nozzle Holder, Pipe, Filter, Prefilter

Capacity	650 mL
Continuous Use (min.)	w/ BL1830B: 20
Max Air Flow	1.4 m ³ /min
Max Sealed Suction	4.2 kPa (428 mmH ₂ O)
Suction Power	30 W
Dimensions (L x W x H)	999x114x152 mm (39-1/4"x4-1/2"x6")
Net weight	1.2 kg (2.7 lbs.)

DCL180FRFW**DCL280F**

Cordless Cleaner

**18V LXT BL Brushless Cordless Cleaner with LED Light**

- More Advanced Features for Professional Use
- Increased suction power achieved by using highly efficient BL motor
- BL motor is electronically controlled to optimize battery energy use for longer run time per charge
- Quiet cleaning achieved by noise absorbing sponge attached inside housing
- Low vibration; using softer elastomer for the part that fixes fan cover, the vibration of housing is reduced, increasing comfort even in long continuous cleaning

**LXT BL MOTOR**

Floor Nozzle, Sash Nozzle, Sash Nozzle Holder, Pipe, Long Sash Nozzle, Holder, Filter, Prefilter, Easy Shake Off Filter, Hand Strap, Battery, Charger

Capacity	750 mL
Continuous Use (min.)	w/ BL1830B: 20
Max Air Flow	1.4 m ³ /min
Max Sealed Suction	6.4 kPa (640 mmH ₂ O)
(water column)	
Suction Power	w/ Normal Filter: 45 W
	w/ Easy Shake Off Filter: 40 W
Vibration Level	0.2 m/s ²
Noise Level	70 dB(A)
Dimensions (L x W x H)	1,016x113x155 mm (40"x4-7/16"x6-1/8")
Net weight	1.2 - 1.6 kg (2.7 - 3.5 lbs.)

DCL280FRFW**DCL281F**

Cordless Cleaner

**18V LXT BL Brushless Cordless 3-Speed Cleaner with LED Light**

- More Advanced Features for Professional Use
- Increased suction power achieved by using highly efficient BL motor
- BL motor is electronically controlled to optimize battery energy use for longer run time per charge
- Quiet cleaning achieved by noise absorbing sponge attached inside housing
- Low vibration; using softer elastomer for the part that fixes fan cover, the vibration of housing is reduced, increasing comfort even in long continuous cleaning

**LXT BL MOTOR**

Floor Nozzle, Sash Nozzle, Sash Nozzle Holder, Pipe, Long Sash Nozzle, Holder, Filter, Prefilter, Easy Shake Off Filter, Hand Strap, Battery, Charger

Capacity	750 mL
Continuous Use (min.)	w/ BL1830B Max / High / Normal: 15 / 20 / 50
Max Air Flow	1.5 m ³ /min
Max Sealed Suction	8.2 kPa (820 mmH ₂ O)
(water column)	
Suction Power	w/ Normal Filter, Max / High / Normal: 60 / 45 / 15
	w/ Easy Shake Off Filter, Max / High / Normal: 55 / 40 / 13
Vibration Level	0.2 m/s ²
Noise Level	71 / 70 / 63 dB(A)
Dimensions (L x W x H)	Max / High / Normal: 71 / 70 / 63 dB(A)
	1,016x113x154 mm (40"x4-7/16"x6-1/16")
Net weight	1.2 - 1.6 kg (2.7 - 3.5 lbs.)

DCL281FRFW**DCL282F**

Cordless Cleaner

**18V LXT BL Brushless Cordless 3-Speed Cleaner with LED Light**

- More Advanced Features for Professional Use
- Increased suction power achieved by using highly efficient BL motor
- BL motor is electronically controlled to optimize battery energy use for longer run time per charge
- Quiet cleaning achieved by noise absorbing sponge attached inside housing
- Low vibration; using softer elastomer for the part that fixes fan cover, the vibration of housing is reduced, increasing comfort even in long continuous cleaning

**LXT BL MOTOR**

Floor Nozzle, Sash Nozzle, Sash Nozzle Holder, Pipe, Long Sash Nozzle, Holder, Filter, Prefilter, Easy Shake Off Filter, Hand Strap, Battery, Charger

Capacity	Normal Dust Bag / Paper Filter: 500 / 330
Continuous Use (min.)	w/ BL1830B Max / High / Normal: 15 / 20 / 50
Max Air Flow	1.5 m ³ /min
Max Sealed Suction	8.2 kPa (820 mmH ₂ O)
(water column)	
Suction Power	w/ Normal Filter, Max / High / Normal: 60 / 45 / 15
	w/ Paper Filter, Max / High / Normal: 60 / 45 / 15
	w/ Easy Shake Off Filter, Max / High / Normal: 55 / 40 / 13
Vibration Level	0.2 m/s ²
Noise Level	Max / High / Normal: 72 / 71 / 65 dB(A)
Dimensions (L x W x H)	1,016x114x154 mm (40"x4-1/2"x6-1/16")
Net weight	1.3 - 1.6 kg (2.8 - 3.5 lbs.)

DCL282FRFW

DUR190L

18V LXT BL ADT AFT Cordless Grass Trimmer, Loop Handle

Cordless Grass Trimmer

new



- One protector for metal blade / plastic blade / trimmer head
- Toolless shaft lock for plastic blade change
- Automatic Torque Drive Technology (ADT) adjusts speed and torque during operation for optimum performance
- Active Feedback Sensing Technology (AFT) turns the motor off if blade rotation is suddenly forced to stop
- BL motor delivers up to 6,000 RPM for faster cutting

LXT BL MOTOR ADT AFT XPT



Safety Goggles, Band Assembly, Nylon Cutting Head, Accessory Bag, Hex Wrench, Battery, Charger, Cap

Cutting Width	Trimmer Head: 300 mm (11-3/4")
	Metal Blade: 230 mm (9")
	Plastic Blade: 230 mm (9")
No Load Speed (RPM)	3,500 - 6,000
Spindle Size	M8 x 1.25 LH
Dimensions (L x W x H)	1,834x348x236 mm (72-1/4"x13-3/4"x9-1/4")
Net weight	2.9 - 3.3 kg (6.5 - 7.2 lbs.)

DUR190LRT1
DUR190LZX1

DUR190U

18V LXT BL ADT AFT Cordless Grass Trimmer, Bike Handle

Cordless Grass Trimmer

new



- One protector for metal blade / plastic blade / trimmer head
- Toolless shaft lock for plastic blade change
- Automatic Torque Drive Technology (ADT) adjusts speed and torque during operation for optimum performance
- Active Feedback Sensing Technology (AFT) turns the motor off if blade rotation is suddenly forced to stop
- BL motor delivers up to 6,000 RPM for faster cutting

LXT BL MOTOR ADT AFT XPT



Safety Goggles, Band Assembly, Nylon Cutting Head, Accessory Bag, Hex Wrench, Battery, Charger, Cap

Cutting Width	Trimmer Head: 300 mm (11-3/4")
	Metal Blade: 230 mm (9")
	Plastic Blade: 230 mm (9")
No Load Speed (RPM)	3,500 - 6,000
Spindle Size	M8 x 1.25 LH
Dimensions (L x W x H)	1,834x610x473 mm (72-1/4"x24"x18-5/8")
Net weight	3.1 - 3.4 kg (6.7 - 7.4 lbs.)

DUR190URT1
DUR190UZX1

BL MOTOR

**Brushless DC motor
Max. 6,000min⁻¹**

:: Maintenance-free due to no brush
:: Energy production is more efficient than brushed DC motor because of no friction loss caused by brushes, enabling to lower amperage for reduced heat production and increased work amount on a single full battery charge.



AFT Active Feedback sensing Technology

Torque limiter turns the motor off if the tool is suddenly forced to lock

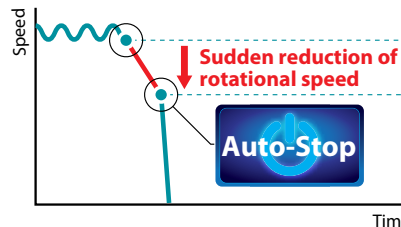

ADT Automatic torque Drive Technology

RPM is automatically shifted to 3,500 - 6,000 min⁻¹ according to density of weeds.



Also the speed can be changed between 4,000/5,000/6,000 manually by pressing the button.

All control devices are conveniently located near your hand.

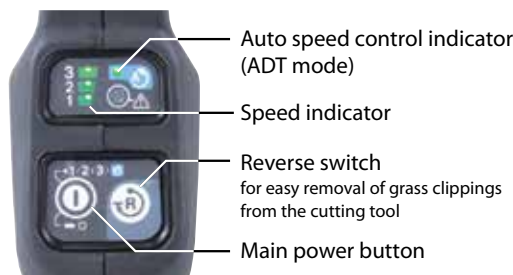

Automatic torque Drive Technology



This movie was filmed in Japan. Models and specs may vary by country.

DUX18 18V LXT BL AFT Cordless Multi Function Power Head

Cordless Multi Function Power Head

new



- Split system of Power head and Attachment provides easier portability
- The system consisting of a power head and versatile optional attachments is ideal for a wide range of garden and agricultural applications
- High power BL motor enables to work under heavy load
- Active Feedback sensing Technology (AFT) turns the motor off if rotation speed suddenly slows
- High/Low 2-speed selection and variable speed control by trigger
- Simple non-directional drive shaft allows for easy insertion of attachments into the power head

LXT BL MOTOR AFT XPT



Harness, Safety Goggles, Hex Wrench, Accessory Bag, Carbide-Tipped Saw Blade (for spec with EM402MP only), Box Wrench (for spec with EM402MP/EM408MP/EM409MP only), Nylon Cutting Head (for spec with EM408MP/EM409MP only), Battery, Charger

No Load Speed (RPM)	High / Low: 0 - 9,700 / 0 - 6,800
Dimensions (L x W x H)	w/ BL1830B / BL1840B / BL1850B / BL1860B: 977 x 318 x 175 mm (38-3/4 x 12-1/2 x 6-7/8")
Net weight	2.8 - 10.3 kg (6.2 - 22.7 lbs.)

Not compatible with 2.0Ah, 1.5Ah batteries

DUR187L 18V LXT BL ADT Cordless Grass Trimmer, Loop Handle

Cordless Grass Trimmer



- ADT (Automatic Torque Drive Technology) adjusts speed and torque during operation for optimum performance
- Lightweight and compact head for reduced operator fatigue
- Plastic triple blade for heavy duty operation
- Plastic triple blade with streamline and protrusion reduce air resistance and noise
- Easy plastic blade replacement only by removing cover

LXT BL MOTOR ADT XPT



Safety Goggles, Shoulder Harness, Nylon Cutting Head, Plastic Blade, Accessory Bag, Hex Wrench,

Cutting Width	Nylon Cutting Head: 300 mm (11-3/4") Plastic Blade: 255 mm (10")
No Load Speed (RPM)	High / Med / Low / ADT Mode: 6,000 / 5,000 / 4,000 / 4,000 - 6,000
Spindle Size	M8 x 1.25 LH
Sound Pressure Level	Nylon Cutting Head: 74 dB(A)
Sound Power Level	Nylon Cutting Head: 84 dB(A)
Vibration Level	Front / Rear: 2.5 / 2.5 m/s ² or less
Dimensions (L x W x H)	1,791x258x232 mm (70-1/2"x10-1/8"x9-1/8")
Max Run Time (min)	Nylon Cutting Head, BL1860B: 168 Plastic Blade, BL1860B: 219
Net weight	3.4 - 3.7 kg (7.5 - 8.2 lbs.)

DUR187L RFE
DUR187LZ

DUC254 18V LXT BL Brushless Cordless 25 cm (10") Chain Saw

Cordless Chain Saw



- High Cutting Performance, Ultra Lightweight Top Handle Chain Saw Equivalent to Compact Engine Chain Saw
- Outer Rotor BL Motor direct-drive system provides high cutting performance equivalent to a compact engine chain saw; 0-24.0 m/s (0-1,440 m/min) (0-4,720 FPM)
- Thick branch mode / torque boost mode enables to cut thick branches by temporarily boosting current limiter
- Ideal for pruning application

LXT BL MOTOR



Saw Chain, Guide Bar, Guide Bar Cover, Wrench, Accessory Bag

Guide Bar Length	250 mm (10")
Cutting Length	240 mm (N/A")
Chain Pitch	3/8"
Chain Gauge	1.1 mm (0.043")
Chain Speed	0 - 24 m/s (0 - 1,440 m/min) (0 - 4,720 FPM)
Sound Pressure Level	92.2 dB(A)
Vibration Level	Cutting Wood: 3.1 m/s ²
Dimensions (L x W x H)	w/o Guide Bar: 258x184x191 mm (10-1/8"x7-1/4"x7-1/2") w/ 25 cm (10") 90PX Sprocket Nose Bar: 482x184x191 mm (19"x7-1/4"x7-1/2") w/ 25 cm (10") 25AP Sprocket Nose Bar: 493x184x191 mm (19-3/8"x7-1/4"x7-1/2")
Net weight	2.8 - 3.2 kg (6.2 - 6.9 lbs.)

DUC254Z

DUM604 18V LXT Li-Ion Cordless 16 cm (6-5/16") Grass Shear

Cordless Grass Shear



- Ergonomically designed handle with sure grip provides more control and comfort
- Grass receiver for reduced grass clean-ups
- 2,500 SPM for efficient cutting
- 2 in 1: Both trimmer blade and shear blade can be attached

LXT 2in1



Grass Receiver, Blade Cover, Battery, Charger

Cutting Width	160 mm (6-5/16")
Depth Adjustment	15, 20, 25 mm (9/16", 13/16", 1")
Strokes Per Minute (SPM)	2,500
Sound Pressure Level	76 dB(A)
Vibration Level	2.5 m/s ² or less
Dimensions (L x W x H)	337x177x131 mm (13-1/4"x7"x5-1/8")
Net weight	1.4 - 1.8 kg (3.2 - 3.9 lbs.)

DUM604SY
DUM604Z

Tool-less blade change system

- Grass shear blade can be removed / installed without tool.
- Hedge trimmer blade can be removed / installed by using a coin to loosen / tighten two screws.



for Hedge
2-Tools
in One
for Grass

DCU180

18V LXT BL Brushless Battery Powered Wheelbarrow, 130 Kg (290 Lbs.) Capacity

Battery Powered Wheelbarrow



- Move Heavy Loads with No Back Pain
- Ideal for use at urban construction sites and on farms
- Handles loads up to 130 kg (290 lbs.)
- Dual LED job lights for more visibility
- Hauls all kinds of heavy loads with optional heavy duty carrier and bucket



LXT BL MOTOR XPT



Lock Key, Support Legs, Wrenches

Max Run Time (min)	w/ BL1860B x2: 120
Max Load Capacity	130 kg (290 lbs.)
Traveling Speed	Forward, High / Low: 0 - 3.5 / 0 - 1.5 km/h Reverse: 0 - 1 km/h
Max Climbing Capacity	12°
Dimensions (L x W x H)	When carrier is installed / During operation: 1,315x1,060x900 mm (51-3/4"x41-3/4"x35-1/2")
Net weight	39.3 - 44.8 kg (86.5 - 98.7 lbs.)

DCU180Z



Powered by LXT 18V battery

Battery box is able to hold two selectable batteries



DUH604

18V LXT BL Brushless Cordless Hedge Trimmer

Cordless Hedge Trimmer

new



- Excellent balance of high power and lightweight maneuverability
- 3-speed (High: 4,400, Medium: 3,600, Low: 2,000 SPM) design for optimum speed control
- Reverse rotation system frees the blade when it is jammed by thick branches
- BL motor delivers 4,400 SPM for faster cutting
- Constant speed control maintains constant speed under load
- Low noise; Noise emission is lower than engine hedge trimmers
- Chip receiver optimized for the cutting width



LXT BL MOTOR XPT



Blade Cover, Safety Goggles (country-specific), Chip Receiver (country-specific), Battery, Charger

Blade Length	600 mm (23-5/8")
Max Cutting Capacity	23.5 mm (15/16")
Sound Pressure Level	79.3 dB(A)
Sound power level	90.3 dB (A)
Vibration Level	2.5 m/s ² or less
Strokes Per Minute (SPM)	High / Med / Low: 0 - 4,400 / 0 - 3,600 / 0 - 2,000
Dimensions (L x W x H)	1,057x280x147 mm (41-1/2"x11"x5-3/4")
Net weight	4.0 kg (8.8 lbs.)

DUH604SRT
DUH604SZ

DUH754

18V LXT BL Brushless Cordless Hedge Trimmer

Cordless Hedge Trimmer

new



- Optimum blade shape for smooth cutting
- Twigs are caught easily and held firmly
- Anti-Vibration Structure
- consisting of Motor-crank section and handle section linked by 5 cushions to absorb vibration from blade and motor-crank section
- Ideal for pruning application
- Locks at 45° and 90° left and right and 0°.
- Makes vertical and angled trimming easier and faster.



LXT BL MOTOR XPT



Blade Cover, Safety Goggles (country-specific), Chip Receiver (country-specific), Battery, Charger

Blade Length	750 mm (29-1/2")
Max Cutting Capacity	23.5 mm (15/16")
Sound Pressure Level	80.6 dB(A)
Sound power level	91.6 dB (A)
Vibration Level	2.5 m/s ² or less
Strokes Per Minute (SPM)	High / Med / Low: 0 - 4,400 / 0 - 3,600 / 0 - 2,000
Dimensions (L x W x H)	1,198x280x147 mm (47-1/4"x11"x5-3/4")
Net weight	4.1 kg (9.0 lbs.)

DUH754SRT
DUH754SZ

DUH502

Cordless Hedge Trimmer

18V LXT BL Brushless Cordless Hedge Trimmer



- Optimum blade shape for smooth cutting
- Twigs are caught easily and held firmly
- Anti-Vibration Structure
- consisting of Motor-crank section and handle section linked by 5 cushions to absorb vibration from blade and motor-crank section
- Ideal for pruning application
- Locks at 45° and 90° left and right and 0°.
- Makes vertical and angled trimming easier and faster.



Blade Cover, Safety Goggles (country-specific)

Blade Length	500 mm (19-3/4")
Strokes Per Minute	High / Med / Low:
(SPM)	0 - 4,400 / 0 - 3,600 / 0 - 2,000
Max Output	-
Dimensions	1,016x192x225 mm
(L x W x H)	(40"x7-1/2"x8-7/8")
Net weight	3.8 - 4.1 kg (8.3 - 9.0 lbs.)

DUH502RT
DUH502Z

DUH602

Cordless Hedge Trimmer

18V LXT BL Brushless Cordless Hedge Trimmer



- Optimum blade shape for smooth cutting
- Twigs are caught easily and held firmly
- Anti-Vibration Structure
- consisting of Motor-crank section and handle section linked by 5 cushions to absorb vibration from blade and motor-crank section
- Ideal for pruning application
- Locks at 45° and 90° left and right and 0°.
- Makes vertical and angled trimming easier and faster.



Blade Cover, Safety Goggles (country-specific)

Blade Length	600 mm (23-5/8")
Strokes Per Minute	High / Med / Low:
(SPM)	0 - 4,400 / 0 - 3,600 / 0 - 2,000
Max Output	520 W
Dimensions	1,121x192x225 mm
(L x W x H)	(44-1/8"x7-1/2"x8-7/8")
Net weight	3.9 - 4.3 kg (8.5 - 9.4 lbs.)

DUH602RT
DUH602Z

DUH752

Cordless Hedge Trimmer

18V LXT BL Brushless Cordless Hedge Trimmer



- Optimum blade shape for smooth cutting
- Twigs are caught easily and held firmly
- Anti-Vibration Structure
- consisting of Motor-crank section and handle section linked by 5 cushions to absorb vibration from blade and motor-crank section
- Ideal for pruning application
- Locks at 45° and 90° left and right and 0°.
- Makes vertical and angled trimming easier and faster.



Blade Cover, Safety Goggles (country-specific), Battery, Charger

Blade Length	750 mm (29-1/2")
Max Cutting Capacity	21.5 mm (7/8")
Strokes Per Minute	High / Med / Low:
(SPM)	0 - 4,400 / 0 - 3,600 / 0 - 2,000
Dimensions	1,261x192x225 mm
(L x W x H)	(49-5/8"x7-1/2"x8-7/8")
Net weight	4.1 - 4.4 kg (9.0 - 9.7 lbs.)

DUH752RT
DUH752Z

DVF154

Cordless Garden Sprayer

18V LXT Li-Ion Cordless 15 L Garden Sprayer



- Environment-friendly with no emission and extremely low noise
- Hand valve lever with two selectable modes
- Reduced running cost with rechargeable Li-ion battery
- Compact and lightweight cordless sprayer provides easy handling and high maneuverability
- Two different nozzles included as standard equipment for added versatility



Upright Double-Headed Nozzle, Wide-Angle Herbicide Nozzle, Spray Pipe Holder, Shoulder Harness

Max Pressure	0.3 MPa (3 kgf/cm ²)
Chemical tank	15 L
Dimensions (L x W x H)	345x235x525 mm (13-5/8"x9-1/4"x20-3/4")
Net weight	4.1 - 4.4 kg (9.1 - 9.7 lbs.)

DVF154Z

DVF104

Cordless Garden Sprayer

18V LXT Li-Ion Cordless 10 L Garden Sprayer



- Environment-friendly with no emission and extremely low noise
- Hand valve lever with two selectable modes
- Reduced running cost with rechargeable Li-ion battery
- Compact and lightweight cordless sprayer provides easy handling and high maneuverability
- Two different nozzles included as standard equipment for added versatility



Upright Double-Headed Nozzle, Wide-Angle Herbicide Nozzle, Spray Pipe Holder, Shoulder Harness

Max Pressure	0.3 MPa (3 kgf/cm ²)
Chemical tank	10 L
Dimensions (L x W x H)	315x225x415 mm (12-3/8"x8-7/8"x16-3/8")
Net weight	3.8 - 4.1 kg (8.4 - 9.1 lbs.)

DVF104Z

DUB183

18V LXT Li-Ion Cordless Variable 3-Speed Blower

Cordless Blower

- Long blowing nozzle with curved tip for optimal blowing performance
- 3 Air volume setting (high/medium/low)
- Variable speed (0-18,000 RPM) for optimum speed control
- Ergonomically designed handle with rubberized soft grip
- Anti-static electricity for comfortable operation



LXT



Garden Nozzle

Air volume	2.6 m ³ /min
Air speed	52 m/s
No Load Speed (RPM)	0-18,000
Sound Pressure Level	85 dB(A)
Sound Power Level	95 dB(A)
Vibration Level	2.5 m/s ²
Dimensions (L x W x H)	845x155x212 mm (33-1/4"x6-1/8"x8-3/8")
Net weight	1.7 - 2.0 kg (3.8 - 4.4 lbs.)

This machine cannot be used as a vacuum because it will get clogged with leaf or branch debris.

DUB183Z

DUB184

18V LXT BL Brushless Cordless Variable Speed Blower

Cordless Blower

- Ideal for Clearing Fallen Leaves on Pavement, Grass and Hedge Clippings or Other Light Debris
- Efficient clearing thanks to a high-efficiency axial fan similar to that of 18Vx2 LXT model DUB362
- Variable speed control by trigger, with Cruise control lever for lock-on operation
- BL motor delivers up to 52.1 m/s and 13.0 m³/min
- Compact and lightweight for single handed operation
- Conveniently located hole on housing bottom for easy storage



LXT



Shoulder Belt, Nozzle, Battery, Charger, Hex Wrench

Max Air Volume	13.0 m ³ /min (459 CFM)
Max Air Velocity	52.1 m/s (116 MPH)
No Load Speed (RPM)	0 - 18,000
Blowing Force	10.9 N
Continuous Use (min.)	w/ BL1860B: 12 w/ BL1850B: 10
Sound Pressure Level	86.6 dB(A)
Noise K Factor	1.4 dB(A)
Sound Power Level	93.5 dB(A)
Vibration Level	2.5 m/s ² or less
Dimensions (L x W x H)	w/ BL1815N / BL1820B: 810x160x285 mm (32"x6-5/16"x11-1/4")
Net weight	2.5 - 3.0 kg (5.4 - 6.7 lbs.)

DUB184ST

DUB184Z

DUB186

18V LXT Cordless Variable 3-Speed Blower

Cordless Blower

new

- Drastically increased air volume for higher blowing efficiency
- Larger air volume has been obtained by increasing the air outlet diameter
- Delivers a maximum air speed of 68 m/s for faster job site clean up
- Variable 3-speed for optimum speed control
- Compact and lightweight for single handed operation
- Soft grip provides increased comfort on the job
- Supplied with a garden nozzle for blowing fallen leaves
- Compatible with various accessories



LXT



Garden Nozzle, Battery, Charger

Max Air Volume	3.2 m ³ /min
Max Air Velocity	68 m/s
No Load Speed (RPM)	0 - 18,000
Blowing Force	2.5 N
Run Time (min)	w/ BL1850(B), High / Mid / Low: 20 / 50 / 130 w/ BL1850(B), High / Mid / Low: 12 / 30 / 80
Sound Pressure Level	82.5 dB(A)
Noise K Factor	2.3 dB(A)
Sound Power Level	92.4 dB(A)
Vibration Level	Operation w/o Load: 2.5 m/s ² or less
Dimensions (L x W x H)	w/ BL1815N / BL1820B: 859 x 156 x 195 mm (33-3/4 x 6-1/8 x 7-5/8")
Net weight	1.6 - 2.1 kg (3.5 - 4.6 lbs.)

DUB186RT

DUB186Z

Max Air Volume
3.2 m³/min

Max Air Velocity
98 m/s



3-speed dial + variable speed switch for optimum speed control

Larger air volume has been obtained by increasing the air outlet diameter.

Select Makita, Connect Electricity

USB Charging



Lights

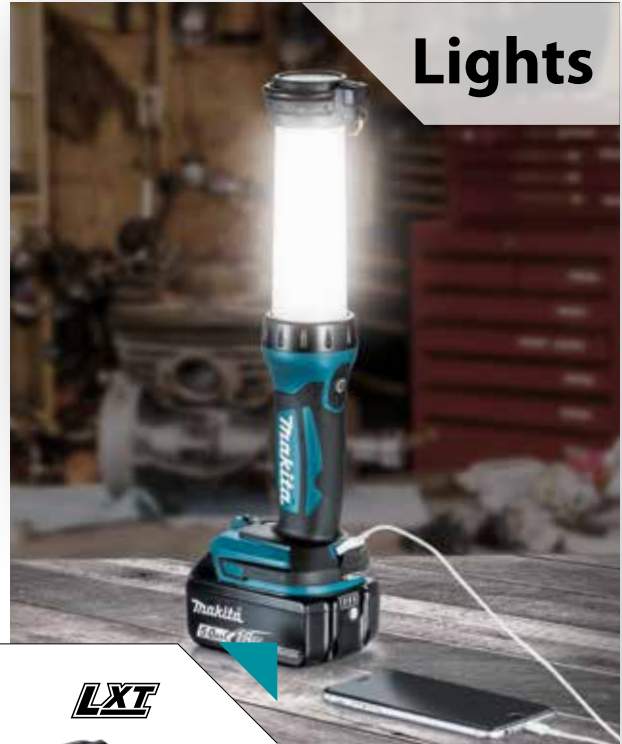

12Vmax



18V



Radios



**Fan Jackets
Heated Jackets**

Battery, USB cable, Smart phone are options.

Black out? Grab your Makita battery



DML805 Corded and Cordless LED Worklight

18V / 14.4V LXT Li-Ion Cordless/Corded 20 LED Worklight, 750 Lumens



Run Time (hrs)	Up to: 17
Illuminance	at 0.5m from the light source Hi: 1,150 lx, Lo: 750 lx
Luminous flux	at 1m from the light source Hi: 300 lx, Lo: 200 lx Hi: 750 lm, Lo: 450 lm
Net weight	2.3 - 2.7 kg (5.1 - 5.9 lbs.)

Battery and charger are sold separately. Power supply cord: 2.5m (8.2ft)

DML805



DML800 Rechargeable Flashlight

18V / 14.4V LXT Li-Ion LED Flashlight, 100 Lumens



Run Time (hrs)	Up to: 30
Dimensions (L x W x H)	151x76x88 mm (5-15/16"x3"x3-1/2")
Net weight	0.53 - 0.91 kg (1.2 - 2.0 lbs.)

DML800

Head Band

DML815 LED Flashlight

18V / 14.4V LXT Li-Ion LED Flashlight, 160 Lumens



Run Time (hrs)	Up to: 54
Luminous Flux	160 lm
Illuminance	at 1m from the light source: 3,000 lx
Dimensions (L x W x H)	w/ BL1830B / BL1840B / BL1850B / BL1860B : 272 x 79 x 116 mm (10-3/4 x 3-1/8 x 4-9/16")
Net weight	0.26 - 0.93 kg (0.57 - 2.05 lbs.)

Battery & Charger Sold Separately



Strap Hook



DCF102 Cordless Fan

18V / 14.4V LXT Li-Ion Cordless 180 mm (7-1/8") Automatic Swing Fan



Continuous Use (min.)	w/ BL1860B Low / Mid / High: 1,270 / 705 / 575 w/ BL1815N Low / Mid / High: 295 / 165 / 135 w/ BL1460B Low / Mid / High: 860 / 465 / 365 w/ BL1415N Low / Mid / High: 245 / 135 / 105
Air Flow	High / Mid / Low: 4.6 / 3.8 / 3.0 m³/min
Dimensions (L x W x H)	185 x 272 x 284 mm (7-1/4 x 10-3/10 x 11-1/8")
Net weight	1.3 - 2.0 kg (2.9 - 4.4 lbs.)



DCF102Z

DCF201 Cordless Fan

18V / 14.4V LXT Li-Ion Cordless 250 mm (9-7/8") Fan



Continuous Use (min.)	High: 100-3.0 Ah, 45-1.3 Ah [18 V] / 90-3.0 Ah, 40-1.3 Ah [14.4 V] Low: 200-3.0 Ah, 90-1.3 Ah [18 V] / 180-3.0 Ah, 80-1.3 Ah [14.4 V]
Dimensions (L x W x H)	263 x 330 x 523 mm (10-3/8 x 13 x 20-5/8")
Net weight	2.5 - 2.9 kg (5.5 - 6.3 lbs.)



DCF201Z

AC Adaptor



Cordless Inflator

DMP180



From daily maintenance to outdoor activity.

18V LXT Li-Ion Cordless Inflator

Blows up air in the tires of cars/bikes



18V Cordless



Max air pressure
830 [121PSI]
kPa

PSI / bar / kPa can be changed
Pre-set pressure stop function



LED job Light
for easy operation at dark places.



Digital pressure gauge
provides high visibility with backlight.

Comes with valve adapters (with BL1850B)



Hose can be stored



Valve adapters

Valve shape	Car / Motorcycle	Bicycle	Road bike	Ball	Beach ball / Swim ring
Adapter	American	British	French Part No. TE00000334	For Balls Part No. TE00000335	For Swim rings/ Beach balls Part No. TE00000333
Maximum air pressure: kPa	(approx.) 250	(approx.) 300	(approx.) 700	(approx.) 90	50 and under
Discharge amount: L/ min (at Target pressure)	283	13	25	25	33
a single full battery charge: count	Car tires (215/60R16) 9	Bicycle tires (Size-26inch) 166	Road bike tires (700x23c) 92	Soccer balls (Size-5) 142	Beach balls (dia.30cm) 121



The weight may differ depending on the attachment(s), including the battery cartridge. The lightest and heaviest combination, according to EPTA-Procedure 01/2014, are shown in the table. Items of standard equipment and specifications may vary by country or area.

DMP180

Cordless Inflator



18V LXT Li-Ion Cordless Inflator

- Air discharge amount and work amount are larger than model MP100D
- For inflating tires of cars and bicycles, sport balls, etc.
- The machine stops automatically when preset target pressure is reached
- The machine remembers the pressure setting last time you power off
- High stability on the ground enables to use as a "stationary machine" to reduce operator fatigue
- LED job light for easy operation in the dark



British Adapter, French Adapter, Ball Adapter, Swim Ring Adapter, Battery, Charger

Max Air Pressure	830 kPa (121 PSI) [8.3 bar]
Air Discharge Amount	200 kPa: 12 L/min / 700 kPa: 8 L/min 830 kPa: 7 L/min
Hose Length	65 cm (25-1/2")
Vibration Level	3.6 m/s ²
Vibration K Factor	1.5 m/s ²
Sound Pressure Level	70 dB(A)
Noise K Factor	3 dB(A)
Dimensions (L x W x H)	w/ BL1815N / BL1820B: 246 x 80 x 174 mm (9-11/16 x 3-1/8 x 6-7/8")
Net weight	1.4 - 1.7 kg (3.1 - 3.8 lbs.)

DMP180Z

18V Lithium-ion

G Series



1.5Ah BL1815G

DF457D Cordless Driver Drill

18V Li-Ion Cordless 13 mm (1/2") 38 N-m (340 in.lbs.) Driver Drill, G-Battery



Capacity	Steel: 13 mm (1/2") Wood: 36 mm (1-7/16")
No Load Speed (RPM)	High: 0 - 1,400 Low: 0 - 400
Max Fastening Torque	Hard / Soft: 42 / 24 N-m
Max lock torque	38 N-m (340 in.lbs.)
Dimensions (L x W x H)	221x83x240 mm (8-3/4"x3-1/4"x9-1/2")
Net weight	1.7 kg (3.7 lbs.)

DF457DWE



(+)(-) Bit

HP457D Cordless Hammer Driver Drill

18V Li-Ion Cordless 13 mm (1/2") 38 N-m (340 in.lbs.) Hammer Driver Drill, G-Battery



Capacity	Steel / Wood / Masonry: 13 / 36 / 13 mm (1/2" / 1-7/16" / 1/2")
Impacts Per Minute (IPM)	High / Low: 0 - 21,000 / 0 - 6,000
No Load Speed (RPM)	High / Low: 0 - 1,400 / 0 - 400
Max Fastening Torque	Hard / Soft: 42 / 24 N-m (370 / 210 in.lbs.)
Max lock torque	38 N-m (340 in.lbs.)
Vibration Level	Hammer Drilling into Concrete: 7.0 m/s ² Drilling Into Metal: 2.5 m/s ² or less
Sound Pressure Level	81 dB(A)
Sound Power Level	92 dB(A)
Dimensions (L x W x H)	239x83x240 mm (9-3/8"x3-1/4"x9-1/2")
Net weight	1.7 kg (3.7 lbs.)

HP457DWE



(+)(-) Bit



TD127D Cordless Impact Driver

18V Li-Ion Cordless 140 N-m (1,240 in.lbs.) Impact Driver, G-Battery



Capacity	Machine Screw: M4 - M8 (5/32" - 5/16") Standard Bolt: M5 - M14 (3/16" - 9/16") High Tensile Bolt: M5 - M12 (3/16" - 1/2") Coarse thread (in length): 22 - 125 mm (7/8" - 4-7/8")
No Load Speed (RPM)	0 - 2,300
Impacts Per Minute (IPM)	0 - 3,000
Max Fastening Torque	140 N-m (1,240 in.lbs.)
Dimensions (L x W x H)	173x82x225 mm (6-13/16"x3-1/4"x8-7/8")
Net weight	1.5 kg (3.2 lbs.)

TD127DWE



HP488D Cordless Hammer Driver Drill

18V Li-Ion Cordless 13 mm (1/2") 38 N-m (340 in.lbs.) Hammer Driver Drill, G-Battery



Capacity	Steel / Wood / Masonry : 13 / 36 / 13 mm (1/2" / 1-7/16" / 1/2")
Chuck Capacity	13 mm (1/2")
Impacts Per Minute (IPM)	High / Low: 0 - 21,000 / 0 - 6,000
No Load Speed (RPM)	High / Low: 0 - 1,400 / 0 - 400
Max Fastening Torque	Hard / Soft: 42 / 24 N-m (370 / 210 in.lbs.)
Max Lock Torque	38 N-m (340 in.lbs.)
Dimensions (L x W x H)	239 x 83 x 240 mm (9-3/8 x 3-1/4 x 9-1/2")
Net weight	1.7 kg (3.7 lbs.)

HP488DWE



new

JV183D Cordless Jig Saw

18V Li-Ion Cordless Top Handle Jig Saw, 3 Orbital Settings Plus Straight Cutting, G-Battery



Capacity	Wood: 65 mm (2-9/16") Steel: 6 mm (1/4")
Length of Stroke	18 mm (11/16")
Strokes Per Minute (SPM)	0-2,900
Dimensions (L x W x H)	248x76x196 mm (9-3/4"x3"x7-3/4")
Net weight	2 kg (4.4 lbs.)

JV183DWE



Jig Saw Blade, Hex Wrench

CL183D Cordless Cleaner

18V Li-Ion Cordless Cleaner, G-Battery



Capacity	600 mL
Continuous Use (min.)	w/ BL1815G: 30
Max Air Flow	1.3 m ³ /min
Max Sealed Suction	2.6 kPa (water column)
Suction Power	17 W
Dimensions (L x W x H)	966x102x148 mm (38"x4"x5-7/8")
Net weight	1.2 kg (2.6 lbs.)

CL183DWE



Floor T-Nozzle28, Sash Nozzle, Sash Nozzle Holder, Pipe, Filter, Prefilter



12V^{max}
LITHIUM-ION

4.0Ah 2.0Ah 1.5Ah

EXPAND YOUR LITHIUM-ION LINEUP

- Rechargeable Green Multi Line Laser**
SK209GD / SK312GD
SK40GD / SK20GD / SK10GD
- Multi Line Laser**
SK700GD / SK700D
- 4-point Cross Line Laser**
SK106GD / SK106D
- Cross Line Laser**
SK105GD / SK105D
- Job Site Radio**
DMR107 / DMR108
DMR109 / DMR110
DMR112 / DMR114
DMR115 / DMR300
DMR301 / MR052
- Driver Drill**
DF332D / DF032D
DF333D / DF033D
- Hammer Driver Drill**
HP332D / HP333D
- Impact Driver**
TD110D / TD111D
- Impact Wrench**
TW140D / TW141D
TW160D / TW161D
TW060D
- Rotary Hammer**
HR140D / HR166D
- Ratchet Wrench**
WR100D
- Angle Drill**
DA332D / DA333D
- Angle Impact Driver**
TL064D / TL065D
- Multi Cutter**
CP100D
- Threaded Rod Cutter**
SC103D
- Recipro Saw**
JR103D / JR105D
- Jig Saw**
JV101D / JV102D / JV103D
- Drywall Saw**
SD100D
- Heated Jacket**
CJ105D / CJ106D
- Heated Vest**
CV102D
- Heated Blanket**
CB100D
- Fan**
CF100D / CF101D
- LED Flashlight**
ML103 / ML104
ML105 / ML106
- Fan Jacket**
DFJ212 / DFJ213
DFJ214
- Fan Vest**
DFV210
- Cordless Cleaner**
CL106D / CL107D
CL108D / CL121D
- Blower**
UB100D / UB101D
- Hedge trimmer**
UH201D
- Pin Nailer**
PT354D
- Multi tool**
TM30D
- Inflator**
MP100D
- Hedge Trimmer**
UN460WD
- Garden Sprayer**
US053D
- Grass Shear**
UM600D
- Grass Trimmer**
UR100D
- Stapler**
ST113D
- Sander Polisher**
PV301D
- Caulking Gun**
CG100D
- Adapter for USB**
ADP08 / ADP06



Expand Your lithium-Ion line up

Fast Charging 22 minutes

DC18RE

to fully charge a 1.5Ah slide Li-ion battery



Optimum Charging System

Forced air cooling system DC10SB only

- Stand-by time until the charge starts can be greatly shortened by using charger DC10SB equipped with a built-in cooling fan.
- Effectively cools down every battery cell with the forced air cooling system and the heat sinks.



Cooling fan

Compact and lightweight design

DC10WD provides higher charging performance than DC10WB, but with a more compact and lightweight design. (It's same charging time(50min.) as DC10WB for 1.3Ah battery although the new battery is 1.5Ah.)



Charging status indicator

shows the charging status of a battery being charged in 2 stages: less than 80% and 80% or more.



Wall mountable for charging

can be mounted on the wall for charging, allowing the user to obtain maximum working space on workbench.



Li-ion Battery

Multi-Contact Slide-type Terminal

- Ensures stable contact with tool even under extreme vibration.
- Allows tools to be equipped with an ergonomic handle design.



Battery fuel gauge (BL1020B, BL1040B)

The power remaining in the battery can be indicated in 4 stages simply by pushing a button.

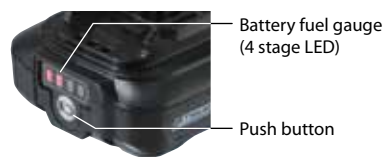

Battery fuel gauge (4 stage LED)

Push button

Charges LXT and CXT battery alternatively

Compatible batteries are:
14.4V/18V LXT batteries &
12V max CXT batteries



Li-ion Battery & Charger Time Reference, Compatibility Chart

	 BL1016 12Vmax 1.5Ah	 BL1021B 12Vmax 2.0Ah with Battery fuel gauge	 BL1041B 12Vmax 4.0Ah with Battery fuel gauge
 DC18RE 	22 min	30 min	60 min
 DC10SB for 12Vmax 	22 min	30 min	60 min
 DC10WD for 12Vmax	50 min	70 min	130 min



**High brightness green laser
for increased visibility at bright site**

Horizontal / 3-Vertical lines

SK312GD

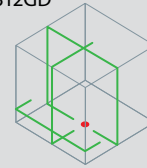

Horizontal / 2-Vertical lines

SK209GD

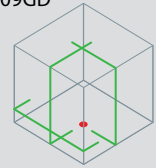

Cross line + Point

SK106GD

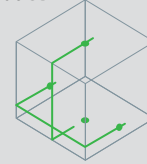

SK106D

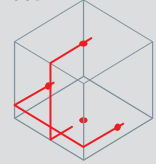

Cross line

SK105GD

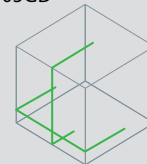

SK105D

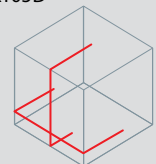

SK312GD/SK209GD

12V max CXT Li-Ion Rechargeable Green Multi Line Laser

Rechargeable Green Multi Line Laser



- High Brightness Green Laser for Increased Visibility at Bright Site
- Horizontal line > Horizontal/vertical line > 3-Vertical line/horizontal line (Loopback switch system)
- High accuracy +/- 1 mm @ 10 m
- Up to 28 hours of continuous illumination in high visibility mode with BL1041B
- Laser wavelength 515 nm / Lower dot beam wavelength 650 nm

CXT XPT

Laser Viewing Glass, Shoulder Strap, Storage Case

Leveling accuracy	±1 mm / 10 m
Self-leveling range	±2°
Laser fan angle	Horizontal: 110° Vertical: 130°
Number of laser lines	SK312D: 4, SK209D: 3
Laser type	Laser class 2: 515 nm
Operating temperature	-10 - 40 °C
Tripod thread	5/8"
Protection class	IP54
Operating Time (Approx. Hours)	SK312D : 10-28 SK209D : 15-40
Dimensions (L x W x H)	w/ BL1016/BL1021B: 122x110x225 mm w/ BL1041B: 122x130x225 mm
Net weight	1.5 - 1.6 kg (3.3 - 3.5 lbs.)
Dimensions (with carry handle in retracted position)	

**SK312GDZ
SK209GDZ**

SK106GD / SK106D

12V max CXT Li-Ion Rechargeable 4-Point Cross Line Laser

Rechargeable 4-point Cross Line Laser



SK106D

- External Power Supply Jack for LXT Battery Use
- High brightness green laser for increased visibility at bright site (SK106GD)
- Up to 20 hours of continuous illumination in high visibility mode with BL1041B
- Line visibility range up to 35 m / 80 m (with Receiver)
- Pendulum lock enables slope incline applications for increased versatility; Offers added protection of laser diode during transport and storage

CXT XPT

Soft bag, Adapter, Target Plate

Measuring range	SK106GD : Up to: 35 m / SK106D : Up to: 25 m
Measuring range w/ detector	Up to: 80 m
Leveling accuracy	±3 mm / 10 m
Self-leveling range	±4°
Laser fan angle	Horizontal: 180° Vertical: 170°
Number of laser points	4
Number of laser lines	2
Laser type	Laser class 2: SK106GD : 525 nm / SK106D : 635nm
Operating temperature	-10 - 50 °C
Operating Time (Approx. Hours)	SK106GD : 7 - 20 SK106D : 15 - 40
Dimensions (L x W x H)	w/ BL1016/BL1021B: 138x64x102 mm (5-7/16"x2-1/2"x4") w/ BL1041B: 157x64x102 mm (6-3/16"x2-1/2"x4")
Net weight	0.69 - 0.85 kg (1.5 - 1.9 lbs.)

**SK106GDZ
SK106DZ**

SK105GD / SK105D

12V max CXT Li-Ion Rechargeable Cross Line Laser

Rechargeable Cross Line Laser



SK105D

- External Power Supply Jack for LXT Battery Use
- High brightness green laser for increased visibility at bright site (SK105GD)
- Up to 20 hours of continuous illumination in high visibility mode with BL1041B
- Line visibility range up to 35 m / 80 m (with Receiver)
- Pendulum lock enables slope incline applications for increased versatility; Offers added protection of laser diode during transport and storage

CXT XPT

Soft bag, Adapter, Target Plate

Measuring range	SK105GD : Up to: 35 m / SK105D : Up to: 25 m
Measuring range w/ detector	Up to: 80 m
Leveling accuracy	±3 mm / 10 m
Self-leveling range	±4°
Laser fan angle	Horizontal: 180° Vertical: 160°
Number of laser lines	2
Laser type	Laser class 2: SK105GD : 525 nm / SK105D : 635nm
Operating temperature	-10 - 50 °C
Operating Time (Approx. Hours)	SK105GD : 7 - 20 SK105D : 15 - 40
Dimensions (L x W x H)	w/ BL1016/BL1021B: 138x64x102 mm (5-7/16"x2-1/2"x4") w/ BL1041B: 157x64x102 mm (6-3/16"x2-1/2"x4")
Net weight	0.67 - 0.84 kg (1.5 - 1.9 lbs.)

**SK105GDZ
SK105DZ**

DF331D 12V max CXT Li-Ion Cordless 10 mm (3/8") 28 N-m (250 in.lbs.) Driver Drill

Cordless Driver Drill



- Slide style battery and improved ergonomic grip
- Variable 2-speed (0-450 & 0-1,700 RPM) for a wide range of drilling and fastening applications
- Increased motor power for higher application speed and max tightening torque
- Best possible ergonomic handle for drilling applications
- Ergonomically designed handle with soft grip provides increased comfort
- L12V max slide battery design enables the tool to stand on its own for user convenience



Phillips Bit, Belt Clip

Capacity	Steel / Wood: 10 / 21 mm (3/8" / 13/16")
No Load Speed (RPM)	High / Low: 0 - 1,700 / 0 - 450
Max Fastening Torque	Hard / Soft: 30 / 14 N-m (270 / 130 in.lbs.)
Vibration Level	Drilling into Metal: 2.5 m/s ² or less
Sound Pressure Level	70 dB(A) or less
Dimensions (L x W x H)	189x66x209 mm (7-7/16"x2-5/8"x8-1/4")
Net weight	1.1 - 1.3 kg (2.4 - 2.8 lbs.)

DF331DWAE
DF331DWYE

DF331DZ

DF333D / DF033D 12V max CXT Li-Ion Cordless 28 N-m (250 in.lbs.) Driver Drill

Cordless Driver Drill



- Compact and Ergonomic Design at Only 179 mm Long (DF333D), 149 mm Long (DF033D)
- Ball bearing reduces chuck wobbling
- Slide style battery and improved ergonomic grip
- Variable 2-speed (0-450 & 0-1,700 RPM) for a wide range of drilling and fastening applications
- Increased motor power for higher application speed and max tightening torque



Phillips Bit, Belt Clip

DF333DNX11
DF333DNX10

DF333DWYE
DF333DZ

DF033DWYE
DF033DZ

Capacity	Steel / Wood: 10 / 21 mm (3/8" / 13/16")
Chuck capacity	DF333D: 0.8 - 10 mm (1/32 - 3/8") DF033D: 6.35 mm (1/4")
No Load Speed (RPM)	High / Low: 0 - 1,700 / 0 - 450
Max Fastening Torque	Hard / Soft: 30 / 14 N-m (270 / 130 in.lbs.)
Max lock torque	28 N-m (250 in.lbs.)
Dimensions (L x W x H)	w/ BL1016/BL1021B: DF333D: 179x66x212 mm (7"x2-5/8"x8-3/8") DF033D: 149x66x212 mm (5-7/8"x2-5/8"x8-3/8") w/ BL1041B: DF333D: 179x66x229 mm (7"x2-5/8"x9") DF033D: 149x66x229 mm (5-7/8"x2-5/8"x9")
Net weight	DF333D: 1.1 - 1.2 kg (2.4 - 2.7 lbs.) DF033D: 0.92 - 1.1 kg (2.0 - 2.4 lbs.)

DF332D / DF032D 12V max CXT BL Brushless Cordless 32 N-m (280 in.lbs.) Driver Drill

Cordless Driver Drill



- Ultra-compact design and more work amount thanks to the newly developed BL motor and newly developed 12V max slide Li-Ion battery
- Slide style battery and improved ergonomic grip
- BL motor delivers 35 N-m of max torque
- BL motor is electronically controlled to optimize battery energy use for longer run time per charge
- BL motor with high power to weight and size ratio



Phillips Bit, Belt Clip

DF332DWYE
DF332DZ

DF032DWYE
DF032DZ

Capacity	Steel / Wood: 10 / 28 mm (3/8" / 1-1/8")
Chuck capacity	DF332D: 0.8 - 10 mm (1/32 - 3/8") DF032D: 6.35 mm (1/4")
No Load Speed (RPM)	High / Low: 0 - 1,500 / 0 - 450
Max Fastening Torque	Hard / Soft: 35 / 21 N-m (310 / 190 in.lbs.)
Max lock torque	32 N-m (280 in.lbs.)
Vibration Level	Drilling Into Metal: 2.5 m/s ² or less
Sound Pressure Level	DF332D: 72 dB(A) DF032D: 71 dB(A)
Dimensions (L x W x H)	DF332D: 154x66x217 mm (6-1/16"x2-5/8"x8-1/2") DF032D: 124x66x217 mm (4-7/8"x2-5/8"x8-1/2")
Net weight	DF332D: 1 - 1.2 kg (2.3 - 2.6 lbs.) DF032D: 0.88 - 1 kg (1.9 - 2.3 lbs.)

HP331D 12V max CXT Li-Ion Cordless 10 mm (3/8") 28 N-m (250 in.lbs.) Hammer Driver Drill

Cordless Hammer Driver Drill



- Compact and ergonomic design at only 193mm long
- Ball bearing reduces chuck wobbling
- Slide style battery and improved ergonomic grip
- Variable 2-speed (0-450 & 0-1,700 RPM) for a wide range of drilling, fastening and hammer drilling applications
- Increased motor power for higher application speed and max tightening torque



Phillips Bit, Belt Clip

Capacity	Steel / Wood / Masonry: 10 / 21 / 8 mm (3/8" / 13/16" / 5/16")
Impacts Per Minute (IPM)	High / Low: 0 - 25,500 / 0 - 6,750
No Load Speed (RPM)	High / Low: 0 - 1,700 / 0 - 450
Max Fastening Torque	Hard / Soft: 30 / 14 N-m (270 / 130 in.lbs.)
Max lock torque	28 N-m (250 in.lbs.)
Dimensions (L x W x H)	201x66x209 mm (7-7/8"x2-5/8"x8-1/4")
Net weight	1.1 - 1.3 kg (2.4 - 2.9 lbs.)

HP331DWAX6
HP331DWAX1
HP331DWAE

HP331DWYE
HP331DZ

HP333D 12V max CXT Li-Ion Cordless 10 mm (3/8") 28 N-m (250 in.lbs.) Hammer Driver Drill

Cordless Hammer Driver Drill



- Compact and ergonomic design at only 193mm long
- Ball bearing reduces chuck wobbling
- Slide style battery and improved ergonomic grip
- Variable 2-speed (0-450 & 0-1,700 RPM) for a wide range of drilling, fastening and hammer drilling applications
- Increased motor power for higher application speed and max tightening torque



Phillips Bit, Belt Clip

Capacity	Steel / Wood / Masonry: 10 / 21 / 8 mm (3/8" / 13/16" / 5/16")
Impacts Per Minute (IPM)	High / Low: 0 - 25,500 / 0 - 6,750
No Load Speed (RPM)	High / Low: 0 - 1,700 / 0 - 450
Max Fastening Torque	Hard / Soft: 30 / 14 N-m (270 / 130 in.lbs.)
Max lock torque	28 N-m (250 in.lbs.)
Dimensions (L x W x H)	w/ BL1016/BL1021B: 193x66x212 mm (7-5/8"x2-5/8"x8-3/8") w/ BL1041B: 193x66x229 mm (7-5/8"x2-5/8"x9")
Net weight	1.1 - 1.3 kg (2.4 - 2.9 lbs.)

HP333DNX11
HP333DNX10

HP333DWYE
HP333DZ

HP332D

Cordless Hammer Driver Drill



- Ultra-compact design and more work amount thanks to the newly developed BL motor and newly developed 12V max slide Lithium-Ion battery
- BL motor delivers 35 N-m of max torque
- BL motor is electronically controlled to optimize battery energy use for longer run time per charge
- BL motor with high power to weight and size ratio
- BL motor eliminates carbon brushes, enabling the BL motor to run cooler and more efficiently for longer life



CXT BL MOTOR XPT



Phillips Bit, Belt Clip

Capacity	Steel / Wood / Masonry: 10 / 28 / 8 mm (3/8" / 1-1/8" / 5/16")
Chuck capacity	0.8 - 10 mm (1/32 - 3/8")
Impacts Per Minute (IPM)	High / Low: 0 - 22,500 / 0 - 6,750
No Load Speed (RPM)	High / Low: 0 - 1,500 / 0 - 450
Max Fastening Torque	Hard / Soft: 35 / 21 N-m (310 / 190 in.lbs.)
Max lock torque	32 N-m (280 in.lbs.)
Vibration Level	Hammer Drilling into Concrete: 12.5 m/s ² Drilling Into Metal: 2.5 m/s ² or less
Sound Pressure Level	82 dB(A)
Sound Power Level	93 dB(A)
Dimensions (L x W x H)	168x66x217 mm (6-5/8"x2-5/8"x8-1/2")
Net weight	1.1 - 1.3 kg (2.4 - 2.8 lbs.)

HP332DWYE
HP332DZ

DA333D / DA332D

Cordless Angle Drill



DA333D



DA332D

- Compact Angle Head Height & Center Height for Use in Close Quarters
- Up to 40% faster drilling and 380% longer runtime*¹
- Slide style battery and improved ergonomic grip
- Part of the expanding 12V max CXT series, combining performance with superior ergonomics in a compact size
- Multi-contact terminals ensure stable contact with battery even under extreme vibration

*1 Compared with DA330D / DA331D



CXT



Chuck Key (DA332D), Chuck Key Holder (DA332D), Bit, Belt Clip

Capacity	Steel: 10 mm (3/8"), Wood: 12 mm (1/2")
No Load Speed (RPM)	0 - 1,100
Head Height	DA333D: 84 mm (3-5/16") / DA332D: 63 mm (2-1/2")
Center Height	23.5 mm (15/16")
Vibration Level	DA333D: Drilling Into Metal: 3.0 m/s ² or less
Sound Pressure Level	70 dB(A) or less
Dimensions (L x W x H)	w/ BL1016/BL1021B: DA333D: 313x68x95 mm (12-3/8"x2-11/16"x3-3/4") DA332D: 313x68x86 mm (12-3/8"x2-11/16"x3-3/8") w/ BL1041B: DA333D: 332x68x95 mm (13-1/8"x2-11/16"x3-3/4") DA332D: 332x68x86 mm (13-1/8"x2-11/16"x3-3/8")
Net weight	DA333D: 1.2 - 1.4 kg (2.7 - 2.9 lbs.) DA332D: 1.2 - 1.3 kg (2.6 - 2.9 lbs.)

DA333DWAE
DA333DWYE
DA333DZ

DA332DWAE
DA332DWYE
DA332DZ

TD111D

Cordless Impact Driver



- Ultra compact and slim design at only 135 mm (5-5/16") long
- Ultra lightweight for reduced operator fatigue
- Power-increased motor delivers 135 N-m (1,200 in.lbs.) of Max Torque in an ultra compact size
- 3-Mode operation: A-mode / Hard mode / Soft mode for multiple applications
- A-Mode feature helps eliminate "screw cam-out" and "cross threading" by driving at low speed until tightening begins



CXT BL MOTOR XPT



Phillips Bit, Belt Clip

Capacity	Machine Screw: M4 - M8 mm (5/32" - 5/16") Standard Bolt: M5 - M14 (3/16" - 9/16") High Tensile Bolt: M5 - M12 (3/16" - 1/2") Coarse thread (in length): 22 - 90 mm (7/8" - 3-1/2")
Hex Shank	6.35 mm (1/4")
No Load Speed (RPM)	Hard / Soft: 0 - 3,000 / 0 - 1,300
Impacts Per Minute (IPM)	Hard / Soft: 0 - 3,900 / 0 - 1,600
Max Fastening Torque	135 N-m (1,200 in.lbs.)
Vibration Level	Impact tightening of fasteners of the maximum capacity of the tool: 12.5 m/s ²
Sound Pressure Level	94 dB(A)
Sound Power Level	105 dB(A)
Dimensions (L x W x H)	135x66x210 mm (5-5/16"x2-5/8"x8-1/4")
Net weight	0.97 - 1.1 kg (2.1 - 2.5 lbs.)

TD111DWAE
TD111DWYE

TD111DZ

TD110D

Cordless Impact Driver



- Slide style battery and improved ergonomic grip
- Variable speed (0-2,600 RPM & 0-3,500 IPM) for a wide range of fastening applications
- Power-increased motor delivers 110 N-m (970 in.lbs.) of Max Torque in an ultra compact size
- Best possible ergonomic handle for screwdriving applications
- Ergonomically designed handle with soft grip provides increased comfort



CXT



Belt Clip, Phillips Bit

Capacity	Machine Screw: M4 - M8 mm (5/32" - 5/16") Standard Bolt: M5 - M12 (3/16" - 1/2") High Tensile Bolt: M5 - M10 (3/16" - 3/8") Coarse thread (in length): 22 - 90 mm (7/8" - 3-1/2")
Hex Shank	6.35 mm (1/4")
No Load Speed (RPM)	0 - 2,600
Impacts Per Minute (IPM)	0 - 3,500
Max Fastening Torque	110 N-m (970 in.lbs.)
Vibration Level	8.0 m/s ²
Sound Pressure Level	94 dB(A)
Sound Power Level	105 dB(A)
Dimensions (L x W x H)	153x66x204 mm (6"x2-5/8"x8-1/8")
Net weight	1.0 - 1.2 kg (2.3 - 2.6 lbs.)

TD110DWAE
TD110DWYE

TD110DZ

TL064D

Cordless Angle Impact Driver



- Compact & lightweight right angle impact driver for fastening and loosening in tight spaces
- 60 N-m (530 in.lbs.) of maximum torque and 0-3,000 IPM
- Variable speed (0-2,000 RPM) for a range of applications from auto repair to cabinet installation
- Large conveniently located paddle switch for comfortable operation
- Over one foot of tool extension for extra reach into deep tight spaces



CXT



Phillips Bit, Belt Clip

Capacity	Machine Screw: M4 - M8 (5/32" - 5/16") Standard Bolt: M4 - M12 (5/32" - 1/2") High Tensile Bolt: M4 - M8 (5/32" - 5/16") Coarse thread (in length): 22 - 75 mm (7/8" - 2-31/32")
Hex Shank	6.35 mm (1/4")
No Load Speed (RPM)	0 - 2,000
Impacts Per Minute (IPM)	0 - 3,000
Max Fastening Torque	60 N-m (530 in.lbs.)
Vibration Level	Impact tightening of fasteners of the maximum capacity of the tool: 15.0 m/s ²
Sound Pressure Level	91 dB(A)
Sound Power Level	102 dB(A)
Dimensions (L x W x H)	361x66x86 mm (14-1/4"x2-5/8"x3-3/8")
Net weight	1.2 - 1.6 kg (2.7 - 3.6 lbs.)

TL064DWYE

TL064DZ

TL065D 12V max CXT Li-Ion Cordless 60 N-m (530 in.lbs.) Angle Impact Wrench

Cordless Angle Impact Wrench

- Compact & lightweight right angle impact wrench for fastening and loosening in tight spaces
- 60 N-m (530 in.lbs.) of maximum torque and 0-3,000 IPM
- Variable speed (0-2,000 RPM) for a range of applications from auto repair to product assembly
- Large conveniently located paddle switch for comfortable operation
- Over one foot of tool extension for extra reach into deep tight spaces



Belt Clip

Capacity	Standard Bolt: M4 - M12 (5/32" - 1/2") High Tensile Bolt: M4 - M8 (5/32" - 5/16")
Square Drive	9.5 mm (3/8")
No Load Speed (RPM)	0 - 2,000
Impacts Per Minute (IPM)	0 - 3,000
Max Fastening Torque	60 N-m (530 in.lbs.)
Vibration Level	Impact tightening of fasteners of the maximum capacity of the tool: 18.0 m/s ²
Sound Pressure Level	90 dB(A)
Sound Power Level	101 dB(A)
Dimensions (L x W x H)	361x66x86 mm (14-1/4"x2-5/8"x3-3/8")
Net weight	1.2 - 1.6 kg (2.7 - 3.6 lbs.)

TL065DWYE
TL065DZ

TW160D 12V max CXT BL Brushless Impact Wrench

Cordless Impact Wrench

- Reverse rotation auto stop mode stops in 0.2 seconds after the bolt/nut loosened enough
- BL motor delivers 2,400 max RPM, 3,600 max IPM
- BL motor is electronically controlled to optimize battery energy use for longer run time per charge
- BL motor eliminates carbon brushes, enabling the BL motor to run cooler and more efficiently for longer life



Belt Clip

Fastening Capacities	Standard Bolt: M8 - M16 (5/16" - 5/8") High Tensile Bolt: M6 - M12 (1/4" - 1/2")
Square Drive	9.5 mm (3/8")
No Load Speed (RPM)	High / Low: 0 - 2,400 / 0 - 1,300
Impacts Per Minute (IPM)	High / Low: 0 - 3,600 / 0 - 2,000
Max Fastening Torque	160 N-m (1,420 in.lbs.)
Dimensions (L x W x H)	w/ BL1016/BL1021B: 144x66x213 mm (5-5/8"x2-5/8"x3-3/8") w/ BL1041B: 144x66x260 mm (5-5/8"x2-5/8"x10-1/4")
Net weight	1.0 - 1.2 kg (2.2 - 2.6 lbs.)

TW160DSAE
TW160DZ

TW161D 12Vmax CXT BL Brushless Cordless 1/2" (12.7 mm) 165 N-m (122 ft.lbs.) Impact Wrench

Cordless Impact Wrench

- Delivers 165 N-m (122 ft.lbs.) of Max Torque in an Ultra Compact Size
- Reverse Rotation Auto-Stop Mode stops in 0.2 seconds after the bolt/nut loosened enough
- BL motor delivers 2,400 max RPM, 3,600 max IPM and 165 N-m of max torque
- BL motor is electronically controlled to optimize battery energy use for longer run time per charge
- BL motor eliminates carbon brushes, enabling the BL motor to run cooler and more efficiently for longer life



Belt Clip, Battery, Charger

Fastening Capacities	Standard Bolt: M8 - M16 (5/16" - 5/8") High Strength Bolt: M6 - M12 (1/4" - 1/2")
Square Drive	12.7 mm (1/2")
No Load Speed (RPM)	Hard / Soft: 0 - 2,400 / 0 - 1,300
Impacts Per Minute (IPM)	Hard / Soft: 0 - 3,600 / 0 - 2,000
Max Fastening Torque	165 N-m (122 ft.lbs.)
Dimensions (L x W x H)	w/ BL1016/BL1021B: 150x66x213 mm (5-7/8"x2-5/8"x3-3/8") w/ BL1041B: 150x66x232 mm (5-7/8"x2-5/8"x9-1/8")
Net weight	1.1 - 1.2 kg (2.4 - 2.7 lbs.)

TW161DSAE
TW161DZ

TW140D 12V max CXT Li-Ion Cordless Impact Wrench

Cordless Impact Wrench

- Variable speed (0-2,600 RPM & 0-3,200 IPM) for a wide range of fastening applications
- Ergonomic shape fits like a glove with even pressure and easy control
- Soft grip handle provides increased comfort on the job
- Ultra compact design at only 168 mm (6-5/8") long and lightweight for reduced operator fatigue



Belt Clip

Fastening Capacities	Standard Bolt: M8 - M16 (5/16" - 5/8") High Tensile Bolt: M6 - M12 (1/4" - 1/2")
Square Drive	9.5 mm (3/8")
No Load Speed (RPM)	0 - 2,600
Impacts Per Minute (IPM)	0 - 3,200
Max Fastening Torque	140 N-m (1,240 in.lbs.)
Dimensions (L x W x H)	w/ BL1016/BL1021B: 161x66x205 mm (6-3/8"x2-5/8"x8-1/8") w/ BL1041B: 161x66x224 mm (6-3/8"x2-5/8"x8-7/8")
Net weight	1 - 1.2 kg (2.3 - 2.7 lbs.)

TW140DWYEX
TW140DWAE

TW140DZ

TW141D 12Vmax CXT Li-Ion Cordless 1/2" (12.7 mm) 145 N-m (107 ft.lbs.) Impact Wrench

Cordless Impact Wrench

- Delivers 145 N-m (107 ft.lbs.) of Max Torque in an Ultra Compact Size
- Variable speed (0-2,600 RPM & 0-3,200 IPM) for a wide range of fastening applications
- Ergonomic shape fits like a glove with even pressure and easy control
- Soft grip handle provides increased comfort on the job
- Ultra compact design at only 168 mm (6-5/8") long and lightweight for reduced operator fatigue
- Ideal for working in tight spaces and overhead applications



Belt Clip, Battery, Charger

Fastening Capacities	Standard Bolt: M8 - M16 (5/16" - 5/8") High Strength Bolt: M6 - M12 (1/4" - 1/2")
Square Drive	12.7 mm (1/2")
No Load Speed (RPM)	0 - 2,600
Impacts Per Minute (IPM)	0 - 3,200
Max Fastening Torque	145 N-m (107 ft.lbs.)
Dimensions (L x W x H)	w/ BL1016/BL1021B: 168x66x205 mm (6-5/8"x2-5/8"x8-1/8") w/ BL1041B: 168x66x224 mm (6-5/8"x2-5/8"x8-7/8")
Net weight	1.1 - 1.2 kg (2.4 - 2.7 lbs.)

TW141DWAE
TW141DWYE

TW141DZ

TW060D

12V max CXT Li-Ion Cordless 1/4" (6.35 mm) 60 N-m (530 in.lbs.) Impact Wrench

Cordless Impact Wrench



- Delivers 60 N-m (530 in.lbs.) of Max Torque in an Ultra Compact Size
- Variable speed (0-2,600 RPM & 0-3,200 IPM) for a wide range of fastening applications
- Ergonomic shape fits like a glove with even pressure and easy control
- Soft grip handle provides increased comfort on the job
- Ultra compact design at only 161 mm (6-3/8") long and lightweight for reduced operator fatigue



Belt Clip

Fastening Capacities	Standard Bolt: M8 - M12 (5/16" - 15/32") High Tensile Bolt: M6 - M10 (1/4" - 3/8")
Square Drive	6.35 mm (1/4")
No Load Speed (RPM)	0 - 2,600
Impacts Per Minute (IPM)	0 - 3,200
Max Fastening Torque	60 N-m (530 in.lbs.)
Dimensions (L x W x H)	w/ BL1016/BL1021B: 161x66x205 mm (6-3/8"x2-5/8"x8-1/8") w/ BL1041B: 161x66x224 mm (6-3/8"x2-5/8"x8-7/8")
Net weight	1 - 1.2 kg (2.3 - 2.6 lbs.)

TW060DWA
TW060DWY

TW060DZ

HR166D

12V max CXT BL Brushless Cordless 16 mm (5/8") Rotary Hammer, SDS-PLUS Bits

Cordless Rotary Hammer



- High-efficiency drilling: Provides up to 50% more runtime, up to 40% more speed^{*1}
- 1.1 Joules (EPTA) impact energy delivers high performance
- Compact, lightweight "palm-size" design for ultimate usability: Suitable for upward and horizontal applications
- Vibration absorbing housing and ergonomic soft rubber grip design for vibration absorption and comfortable operation
- Close-to-hand gravity center for optimum balance and control



Dust Cup (country-specific), Side Grip, Depth Gauge

Impact Energy Capacity	EPTA-Procedure 05/2009: 1.1 J Concrete: 16 mm (5/8") Steel: 10 mm (3/8") Wood: 13 mm (1/2")
Blows Per Minute (BPM)	0 - 4,800
No Load Speed (RPM)	0 - 680
Vibration Level	Hammer Drilling into Concrete: 7.5 m/s ² Drilling Into Metal: 2.5 m/s ² or less
Sound Pressure Level	86 dB(A)
Sound Power Level	97 dB(A)
Dimensions (L x W x H)	w/ BL1016/BL1021B: 250x74x187 mm (9-7/8"x2-15/16"x7-3/8") w/ BL1041B: 250x74x206 mm (9-7/8"x2-15/16"x8-1/8")
Net weight	1.8 - 2.4 kg (4.1 - 5.4 lbs.)

HR166DWA
HR166DWY

HR166DZ

HR140D

12V max CXT Li-Ion Cordless 14 mm (9/16") Rotary Hammer, SDS-PLUS Bits

Cordless Rotary Hammer



- Delivers 0-850 RPM, 0-4,900 BPM and 1.0 Joules of Impact Energy for Faster Drilling
- Compact and lightweight for reduced operator fatigue
- Vibration absorbing housing and ergonomic soft rubber grip design for vibration absorption and comfortable operation
- Dust cup connectable to Makita vacuum cleaner (country-specific): Suitable for upward operation: For cleaner work environment
- Built-in LED light with afterglow function illuminates the work area



Side Grip, Depth Gauge, Dust Cup (country-specific)

Impact Energy Capacity	EPTA-Procedure 05/2009: 1.0 J Concrete: 14 mm (9/16") Steel: 10 mm (3/8") Wood: 13 mm (1/2")
Impacts Per Minute (IPM)	0 - 4,900
No Load Speed (RPM)	0 - 850
Vibration Level	Hammer Drilling into Concrete: 6.5 m/s ² Drilling into Metal: 3.0 m/s ² or less
Sound Pressure Level	84 dB(A)
Sound Power Level	95 dB(A)
Dimensions (L x W x H)	w/ BL1016/BL1021B: 246x74x179 mm (9-11/16"x2-15/16"x7") w/ BL1041B: 246x74x198 mm (9-11/16"x2-15/16"x7-3/4")
Net weight	1.9 - 2.6 kg (4.3 - 5.6 lbs.)

HR140DWA
HR140DWY

HR140DZ

CC301D

12V max CXT Li-Ion Cordless 85 mm (3-3/8") Cutter, Wet Type

Cordless Cutter



- Slide style battery and improved ergonomic grip
- Ergonomically best possible barrel grip for easy handling
- Specifically designed for cutting glass and ceramic tile
- Powerful 1,600 RPM motor delivers fast and powerful cutting
- 85 mm blade delivers a maximum cutting depth of 25.5 mm for a wide range of cutting applications



Diamond Wheel, Water Supply Tank Assembly, Hex Wrench

Blade Diameter	85 mm (3-3/8")
Max Cutting Capacity	90°: 25.5 mm (1") 45°: 16.5 mm (5/8")
No Load Speed (RPM)	1,600
Tank capacity	Water : 0.5 L
Vibration Level	Concrete Cutting: 2.5 m/s ² or less
Sound Pressure Level	84 dB(A)
Sound Power Level	95 dB(A)
Dimensions (L x W x H)	313x170x125 mm (12-3/8"x6-11/16"x4-7/8")
Net weight	1.9 kg (4.1 lbs.)

CC301DWA
CC301DZ

CP100D

12V max CXT Li-Ion Cordless Multi Cutter

Cordless Multi Cutter



- Large Work Amount on a Single Battery Charge
- High power satisfies even professional needs such as carpet contractors
- Cuts thin and thick material up to 6 mm such as cardboard, carpet, fabrics, leather, CD, DVD & Blu-ray
- Handy size for easy maneuverability in various applications for home and professional use
- Auto self-sharpening function maintains sharp performance



Blade

Max Cutting Capacity	6 mm (1/4")
No Load Speed (RPM)	300
Vibration Level	Cutting Cardboard: 2.5 m/s ² or less
Sound Pressure Level	70 dB(A) or less
Dimensions (L x W x H)	w/ BL1016/BL1021B: 272x66x120 mm (10-3/4"x2-5/8"x4-3/4") w/ BL1041B: 291x66x121 mm (11-1/2"x2-5/8"x4-3/4")
Net weight	0.72 - 0.88 kg (1.6 - 1.9 lbs.)

CP100DWA
CP100DZ

Cordless Threaded Rod Cutter

SC103D

new

Great tool balance and Lightweight

Cutting capacities

	W1/4	W5/16	W3/8	1/4-20UNC	5/16-18UNC	3/8-16UNC	M10	M8	M6
Mild steel	✓	✓	✓	✓	✓	✓	✓	✓	✓
Stainless steel	✓	✓	✓	✓	✓	✓	—	✓	✓

*Depending on the type of stainless steel threaded rods, debarring may be necessary after cutting.

High productivity per charge

Work volume on a single full battery charge with BL1041B (4.0Ah)

W3/8 Mild steel
about **700** rods

W3/8 Stainless
about **550** rods

M10 Mild steel
about **550** rods

Long life cutter blade

- High rigidity
- Double-edged blade

Both fixed blade and movable blade are double-edged and can be reversed as "new" ones.



Clean cut surface

Burr-free cuts allow for easy nut tightening.



LED job light



Guide scale

Rod guide



Automatic blade stop mechanism

When the blade reaches full open position, it does not close even if the switch trigger keeps being pulled.



Reversing switch lever

1. Cutting position
2. Lock position
3. Reversing position



Convenient metal hook



Overhead applications



Compact motor section with overall length of **177mm**



Excellent tool balance allows for operation with less wrist fatigue.



Stationary applications

Performs stable cutting even on the floor

Blade cover
Can be used as a rod support.



Rod guide There are two rod guide positions.

Size of threaded rod W3/8, M10

Size of threaded rod W3/16, M6, M6, W1/4

SC103D

12Vmax CXT BL Brushless Cordless Threaded Rod Cutter

Cordless Threaded Rod Cutter

new

- More compact & high productivity
- Cuts up to M10
- Lightweight design for increased maneuverability
- Excellent tool balance allows for operation with less wrist fatigue
- BL motor with high power to weight and size ratio



Cutter Blade, Hex socket head bolt, Blade Cover, Depth Gauge, Thumb screw, Hex Wrench, Battery, Charger

Max Cutting Capacity	Mild Steel: M10 Stainless Steel: W3/8
Min. Cutting Length	20 mm (13/16")
Work Amount (pcs)	W3/8 (Mild Steel) w/ BL1041B: 700 W3/8 (Stainless) w/BL1041B: 550 M10 (Mild Steel) w/BL1041B: 550
Dimensions (L x W x H)	w/ BL1041B: 180x107x289 mm (7-1/8"x4-1/4"x11-3/8")
Net weight	2.7 - 2.8 kg (6.0 - 6.2 lbs.)

SC103DZ

TM30D

12V max CXT Li-Ion Cordless Multi Tool

Cordless Multi Tool



- Slide style battery and improved ergonomic grip
- Ergonomically best possible barrel grip for easy handling
- Delivers up to 32 min of run time using BL1041B under load cutting with plunge saw blade
- Variable speed control dial (6,000-20,000 OPM) enables user to match the speed to the application
- 3.2° Oscillation angle engineered for faster, more aggressive cutting and sanding



Oscillations Per Minute (OPM)	6,000 - 20,000
Oscillation Angle	Left / Right / Total: 1.6° / 1.6° / 3.2°
Vibration Level	Sanding: 2.5 m/s ² or less
	Plunge Saw Blade: 10.5 m/s ²
	Segmental Saw Blade: 5.5 m/s ²
	Scraping: 9.0 m/s ²
Sound Pressure Level	Sanding: 75 dB(A)
	Plunge Saw Blade: 82 dB(A)
	Segmental Saw Blade: 81 dB(A)
	Scraping: 81 dB(A)
Sound Power Level	Plunge Saw Blade: 93 dB(A)
	Segmental Saw Blade: 92 dB(A)
	Scraping: 92 dB(A)
Dimensions (L x W x H)	277x65x98 mm (10-7/8"x2-9/16"x3-7/8")
Net weight	1.1 - 1.3 kg (2.3 - 2.9 lbs.)

TM30DAE
TM30DZ

JV103D

12V max CXT BL Brushless Cordless Top Handle Jig Saw, 3 Orbital Settings Plus Straight Cutting, LED Light

Cordless Jig Saw



- Up to 2.2X Faster Cutting and 2.2X Longer Runtime*¹
- Disabling soft no-load rotation function in operator's preference
- Soft no-load rotation reduces vibration and aligns blade with the cutting line easily
- Toolless blade clamp for easy blade change
- Independent dust nozzle can be attached for connection to Makita vacuum cleaner and doesn't require to be removed even when bevel cutting



Jig Saw Blade, Hex Wrench, Cover Plate (country-specific), Dust Nozzle (country-specific)

Max Cutting Capacity at 90°	Wood / Aluminum / Mild Steel: 90 / 20 / 10 mm (3-1/2" / 13/16" / 3/8")
Length of Stroke	23 mm (7/8")
Strokes Per Minute (SPM)	800 - 3,000
Vibration Level	Cutting Boards: 8.5 m/s ²
	Cutting Sheet Metal: 6.0 m/s ²
Sound Pressure Level	85 dB(A)
Sound Power Level	96 dB(A)
Dimensions (L x W x H)	237x76x206 mm (9-3/8"x3"x8-1/8")
Net weight	1.9 - 2.0 kg (4.1 - 4.4 lbs.)

*¹ Plywood (12x300 mm) cutting without orbital action, compared with JV101D

JV103DWYJ
JV103DZ

JR103D

12V max CXT Li-Ion Cordless Recipro Saw

Cordless Recipro Saw



- Slide style battery and improved ergonomic grip
- Variable speed motor delivers 0-3,300 SPM combined with a 13 mm length stroke to provide faster cutting
- Exclusive dual-position on/off switch design allows for either paddle or trigger switch operation
- Toolless blade change system allows for faster blade installation and removal for increased productivity



Recipro Saw Blades, Hex Wrench

Length of Stroke	13 mm (1/2")
Strokes Per Minute (SPM)	0 - 3,300
Capacity	Pipe / Wood: 50 / 50 mm (2" / 2")
Vibration Level	Cutting Boards: 8.0 m/s ²
	Cutting Wooden Beams: 8.0 m/s ²
Sound Pressure Level	78 dB(A)
Dimensions (L x W x H)	376x66x186 mm (14-3/4"x2-5/8"x7-3/8")
Net weight	1.3 - 1.5 kg (2.9 - 3.3 lbs.)

JR103DWAX6
JR103DWAE

JR103DWYE
JR103DZ

SD100D

12V max CXT Li-Ion Cordless Drywall Saw

Cordless Drywall Saw



- Compact and ergonomic design for reduced operator fatigue
- Ideal for cutting holes in drywalls when setting ceiling lights, air vents etc
- More suitable for straight cuts compared with general cut-out tools
- Dust box designed to catch dust in overhead applications for comfortable work
- Excellent tool balance allows easy overhead application



Blade, Blade Cover, Base Cover, Hex Wrench

Strokes Per Minute (SPM)	0 - 6,000
Length of Stroke	6 mm (1/4")
Capacity	Drywall: 30 mm (1-3/16")
	Wood: 15 mm (9/16")
Vibration Level	Cutting Drywall (thickness 30mm): 3.0 m/s ²
	Cutting Chip Board (thickness 15mm): 5.5 m/s ²
Sound Pressure Level	77 dB(A)
Dimensions (L x W x H)	239x79x266 mm (9-3/8"x3-1/8"x10-1/2")
Net weight	1.4 - 1.6 kg (3.2 - 3.5 lbs.)

SD100DWYJ
SD100DZ

ST113D

12V max CXT Li-Ion Cordless 10 mm (3/8") RT Stapler

Cordless Stapler



- Compact and lightweight for reduced operator fatigue
- Built-in LED job light illuminates the work area
- Operable in either way of "contact actuation" or "single sequential actuation"
- Contact actuation mode drives staples repetitively for quick operation
- Single sequential actuation mode drives one staple by one sequential operation



Safety Goggles, Belt Clip

Staple	Width: 10 mm (3/8")
	Length: 7 - 10 mm (9/32" - 3/8")
	Gauge: 0.5 x 0.7 mm
Magazine Capacity	150 (max 160)
Vibration Level	2.5 m/s ² or less
Sound Pressure Level	75 dB(A)
Dimensions (L x W x H)	211x81x159 mm (8-5/16"x3-1/16"x6-1/4")
Net weight	1.3 kg (2.9 lbs.)

ST113DWYJ
ST113DZ

PT354D 12V max CXT Li-Ion Cordless 23 Ga 35 mm (1-3/8") Pin Nailer

Cordless Pin Nailer



- Low Reaction Force Mechanism Enables Easier Long Pin Nailing and High-Quality Finish
- Easy-to-see slim nose tip allows quick and easy access to a desired fastening point
- Nails can be fired in the groove of baseboard
- Shoots 2,500 nails on a single full BL1041B charge
- Contact arm mechanism enables "continuous nailing" and "drag nailing"



Nose Adapter, Safety Goggles, Belt Clip, Hex Wrench

Capacity	Length: 15, 18, 25, 30, 35 mm (5/8", 11/16", 1", 1-3/16", 1-3/8")
	Dia.: 0.6 mm (1/32")
	Gauge: 23 Ga
Magazine Capacity	120
Vibration Level	2.5 m/s ² or less
Sound Pressure Level	76 dB(A)
Dimensions (L x W x H)	231x66x226 mm (9-1/8"x2-5/8"x8-7/8")
Net weight	1.8 - 2.0 kg (4.0 - 4.4 lbs.)

PT354DWYJ
PT354DZ

CG100D 12V max CXT Li-Ion Cordless Caulking Gun

Cordless Caulking Gun



- Delivers an industry-leading 5,000 N (1,100 lbs) of dispensing force to work with the highest viscosity adhesives and sealants
- 5 Speed dial optimizes flow rate from 0 - 28 mm/sec. (0 - 66 IPM)
- Variable speed trigger allows user to match the speed to the application
- 360° Rotatable cartridge holder fits 800 ml, 600 ml and 300 ml cartridges
- Drip-reduction feature automatically relieves pressure on the material when trigger is released to prevent unintentional dispensing



Holder, Holder Joint, Piston, Rubber Ring, Nozzle

Max Dispensing Force	5,000 N (1,100 lbs)
No load speed	0 - 28 mm/sec. (0 - 66 in/min.)
Holder Size	300, 600, 800 mL
Sound Pressure Level	70 dB(A) or less
Vibration Level	Operation w/o Load: 2.5 m/s ² or less
Dimensions (L x W x H)	404x108x259 mm (15-7/8"x4-1/4"x10-1/4")
Net weight	1.9 - 2.6 kg (4.2 - 5.8 lbs.)

CG100DWAEA
CG100DZA

UR100D 12V max CXT Li-Ion Cordless Grass Trimmer

Cordless Grass Trimmer



- Compact Size Ideal for Trimming and Precise Edging
- Well balanced design with fully adjustable features to suit any operator
- Delivers 10,000 RPM with nylon cutting head for faster cutting
- Up to 55 min. of run time on a single charge under no load using BL1041B and plastic blade
- eXtreme Protection Technology (XPT) is engineered for improved dust and water resistance for operation in harsh conditions



Safety Goggles, Shoulder Belt, Nylon Cutting Head, Nylon Cord, Plastic Blade, Accessory Bag, Hex Wrench

Cutting Width	Nylon Cutting Head: 260 mm (10") Plastic Blade: 230 mm (9")
No Load Speed (RPM)	10,000
Spindle Size	M8 x 1.25 RH
Sound Pressure Level	Nylon Cutting Head: 74 dB(A)
Vibration Level Front / Rear	Nylon Cutting Head: 2.5 / 2.5 m/s ² or less Plastic Blade: 2.5 / 2.5 m/s ² or less
Dimensions (L x W x H)	835 - 1,185x267x210 - 315 mm (32-7/8 - 46-3/4"x10-1/2"x8-1/4 - 12-3/8")
Net weight	1.9 - 2.1 kg (4.3 - 4.6 lbs.)

UR100DWAE
UR100DWAEX

UR100DZ
UR100DZX

UH201D 12V max CXT Li-Ion Cordless 20 cm (7-7/8") Hedge Trimmer

Cordless Hedge Trimmer



- Slimmer handle. More runtime. High performance
- Ergonomically designed handle with sure grip provides more control and comfort
- Up to 90 min of run time on a single battery BL1041B charge
- 2,500 SPM for efficient cutting
- 2 in 1: Both trimmer blade and shear blade can be attached



Blade Cover, Chip Receiver

Blade Length	200 mm (7-7/8")
Tooth Spacing	26 mm (1")
Strokes Per Minute (SPM)	2,500
Continuous Use (min.)	w/ BL1041B / BL1021B / BL1016: 90 / 45 / 35 min
Sound Pressure Level	74 dB(A)
Vibration Level	2.5 m/s ² or less
Dimensions (L x W x H)	504x120x131 mm (19-7/8"x4-3/4"x5-1/8")
Net weight	1.3 - 1.5 kg (2.9 - 3.3 lbs.)

UH201DWY
UH201DZ

UM600D 12V max CXT Li-Ion Cordless 16 cm (6-5/16") Grass Shear

Cordless Grass Shear



- Slimmer handle. More runtime. High performance
- Ergonomically designed handle with sure grip provides more control and comfort
- Up to 90 min of run time on a single battery BL1041B charge
- 2,500 SPM for efficient cutting
- 2 in 1: Both trimmer blade and shear blade can be attached



Grass Receiver, Blade Cover, Battery, Charger

Cutting Width	160 mm (6-5/16")
Depth Adjustment	15, 20, 25 mm (9/16", 13/16", 1")
Strokes Per Minute (SPM)	2,500
Continuous Use (min.)	w/ BL1041B / BL1021B / BL1016: 90 / 45 / 35 min
Sound Pressure Level	75 dB(A)
Vibration Level	2.5 m/s ² or less
Dimensions (L x W x H)	329x177x131 mm (13"x7"x5-1/8")
Net weight	1.3 - 1.5 kg (2.8 - 3.3 lbs.)

UM600DWYE
UM600DZ

Ideal for in-car cleaning

Mat nozzle 120



Seat nozzle 120 complete



Rubber nozzle 330



Soft brush 360 complete

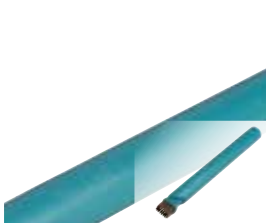

Blower nozzle complete



CL121D

Cordless Cleaner

12V max CXT Li-Ion Cordless 3-Speed Cleaner



- Ideal for in-car cleaning
- Variable attachments suitable for in-car cleaning
- 2 functions in 1 machine convertible into a blower
- Up to 67 min. of continuous use from a single fully charged BL1041B
- Battery capacity warning lamp starts blinking when the remaining battery capacity gets low



Seat vacuum nozzle, Mat nozzle, Rubber nozzle, Soft brush, Blower attachment, Dust Bag, Paper Dust Bag, Shoulder Belt

Capacity	Dust Bag : 500 mL Paper Pack : 330 mL
Continuous Use (w/ BL1041B) (min.)	Max : 27 / High : 32 / Normal : 67
Continuous Use (w/ BL1016) (min.)	Max : 10 / High : 12 / Normal : 25
Max Air Flow	1.3 m ³ /min
Max Sealed Suction (water column)	4.4 kPa (450 mmH ₂ O)
Suction Power	Max : 30 W / High : 20 W / Normal : 5 W
Dimensions (L x W x H)	w/ BL1016/BL1021B: 345x138x202 mm (13-5/8"x5-7/16"x8")
Net weight	1.8 - 2.0 kg (4.0 - 4.4 lbs.)

CL121DWA
CL121DZ

CL108FD

Cordless Cleaner

12V max CXT Li-Ion Cordless 3-Speed Cleaner with LED Light



- Compact and High Suction Power
- Up to 25 min. of continuous use from a single fully charged BL1016
- Built-in LED light illuminates the work area
- Push button switch with air volume selection (Max/High/Normal) for reduced fatigue in continuous use
- IPush button switch with air volume selection (Max/High/Normal) for reduced fatigue in continuous use
- Quick clean-ups with strong suction power debris disposal



Floor Nozzle, Sash Nozzle, Sash Nozzle Holder, Pipe, Filter, Prefilter

Capacity	600mL
Continuous Use (min.)	Max: 10 High: 12 Normal: 25
Max Air Flow	1.2 m ³ /min
Max Sealed Suction (water column)	4.4 kPa (445 mmH ₂ O)
Suction Power	Max: 30 W High: 20 W Normal: 5 W
Dimensions (L x W x H)	956x110x150 mm (37-5/8"x4-5/16"x5-7/8")
Net weight	1.0 - 1.2 kg (2.3 - 2.7 lbs.)

CL108FDWY

CL106FD

Cordless Cleaner

12V max CXT Li-Ion Cordless Cleaner with LED Light



- Stronger suction power for faster cleaning with more run time
- Up to 40 min. of continuous use from a single fully charged BL1041B
- Quick clean-ups with strong suction power
- Redesigned floor nozzle for improved maneuverability and debris collection
- Increased storage capacity for longer time between waste disposal
- Bagless 2-stage cloth filtration system allows for easier cleaning and quicker debris disposal
- Compact and lightweight for reduced operator fatigue



Floor Nozzle, Sash Nozzle, Sash Nozzle Holder, Pipe, Filter, Prefilter

Capacity	600 mL
Continuous Use (min.)	w/ BL1041B: 42
Max Air Flow	1.3 m ³ /min
Max Sealed Suction (water column)	3.1 kPa (316 mmH ₂ O)
Suction Power	19 W
Dimensions (L x W x H)	958x100x150 mm (37-3/4"x4-3/8"x5-7/8")
Net weight	1 - 1.1 kg (2.1 - 2.5 lbs.)

CL106FDWY
CL106FDZ

CL107FD

Cordless Cleaner

12V max CXT Li-Ion Cordless 3-Speed Cleaner with LED Light



- Stronger suction power for faster cleaning with more run time
- Up to 40 min. of continuous use from a single fully charged BL1041B
- Built-in LED light illuminates the work area
- Battery capacity warning lamp starts blinking when the remaining battery capacity gets low
- IPush button switch with air volume selection (Max/High/Normal) for reduced fatigue in continuous use
- Quick clean-ups with strong suction power debris disposal



Floor Nozzle, Sash Nozzle, Sash Nozzle Holder, Pipe, Dust Bag, Paper Dust Bag

Capacity	Dust Bag: 500 mL Paper Pack: 330 mL
Continuous Use (min.)	w/ BL1041B: Max: 20 High: 24 Normal: 50
Max Air Flow	1.4 m ³ /min
Max Sealed Suction (water column)	5.0 kPa (510 mmH ₂ O)
Suction Power	Max: 32 W High: 20 W Normal: 5 W
Dimensions (L x W x H)	960x112x150 mm (37-3/4"x4-3/8"x5-7/8")
Net weight	1.1 - 1.3 kg (2.5 - 2.9 lbs.)

CL107FDWY
CL107FDZ

WR100D 12V max CXT Li-Ion Cordless 47.5 N-m (420 in.lbs.) Ratchet Wrench

Cordless Ratchet Wrench

- Supplied with Two Socket Adapters for Compatibility with a Variety of Sockets
- Equipped with lock-pin style ratchet mechanism is employed, allowing for use as a pass-through ratchet wrench to tighten 13mm nut onto M8 threaded rod
- Easy-to-grip small diameter grip for more comfort and control
- 47.5 N-m (420 in.lbs.) of maximum torque and 0-800 RPM
- Fastens nuts on threaded rods
- Can be also used as a hand ratchet wrench
- LED light with preglow and afterglow functions illuminates the work area



CXT XPT



Socket Adapter, Battery, Charger, Tool Bag

Capacity	Standard Bolt: M5 - M12 (3/16" - 1/2") High Strength Bolt: M5 - M10 (3/16" - 3/8")
Square Drive	9.5 / 6.35 mm (3/8" / 1/4")
No Load Speed (RPM)	0 - 800
Max Fastening Torque	47.5 N-m (420 in.lbs.)
Vibration Level	2.5 m/s ² or less
Sound Pressure Level	74 dB(A)
Noise K Factor	3 dB(A)
Dimensions (L x W x H)	w/ BL1016/BL1021B: 341x67x63 mm (13-7/16"x2-5/8"x2-1/2") w/ BL1041B: 341x67x84 mm (13-7/16"x2-5/8"x3-5/16")
Net weight	1.0 - 1.2 kg (2.3 - 2.7 lbs.)

WR100DWM
WR100DZ

Cordless ratchet wrench powered by 12V max CXT Li-Ion battery



Can also be used as a hand ratchet wrench

Max fastening torque
47.5 N-m

XPT

12V Cordless

MP100D 12V max CXT Li-Ion Cordless Inflator

Cordless Inflator

- Blows Up Air in the Tires of Cars/Bikes
- Digital pressure indicator with back light for increased visibility
- Easy-to-use design on the ground
- Built-in LED light illuminates the work area
- Pre-set pressure stop function



CXT



Valve adapter, Ball adapter, Floating tube adapter

Air Pressure	830 kPa
Max pumping capacity	10 l/min
Dimensions (L x W x H)	w/ BL1016/BL1021B: 235x74x173 mm (9-1/4"x2-15/16"x6-13/16") w/ BL1041B: 255x74x173 mm (10"x2-15/16"x6-13/16")
Net weight	1.2 - 1.3 kg (2.6 - 3.0 lbs.)

MP100DZ

CF101D 12V max CXT Li-Ion Cordless 180 mm (7-1/8") Automatic Swing Fan

Cordless Fan

- Automatically Swings 45° L/R
- Compact size allows installation even in small spaces
- 3-stage automatic timer with 1, 2, and 4 hour power-off selection
- Up to 10.5 hours of continuous runtime on low speed with a 4.0Ah CXT battery (battery not included)
- 3 settings (High 180 m/s, Medium 150 m/s, Low 120 m/s) for optimal air velocity control



CXT



Continuous Use (min.)	w/ BL1041B Low / Med / High: 630 / 380 / 275 w/ BL1021B Low / Med / High: 315 / 190 / 135 w/ BL1016 Low / Med / High: 240 / 145 / 105
Air Flow	High / Med / Low: 4.6 / 3.8 / 3.0 L/min
Dimensions (L x W x H)	185x260x284 mm (7-1/4"x10-1/4"x11-1/8")
Net weight	1.3 - 1.7 kg (2.8 - 3.8 lbs.)

CF101DZ

Fan Jacket Fan Vest

DFJ216A / DFJ312A / DFJ416A /
DFJ212A / DFJ213A / DFJ214A / DFV210A



Heated Jacket Heated Vest

DCJ205 / CJ105D / DCJ206 / CJ106D
DCV202 / CV102D



18V

12V_{max}

Cordless Fan Jacket / Cordless Fan Vest

DFJ210 / DFJ211 / DFJ212 / DFJ213 / DFJ214 / DFV210

Two Fan units cool you down efficiently for more comfort.



Max Air Flow
2.2 m³/min
(Turbo mode)



Thin, Flat Fan units do not disturb your operation.

New Fan unit: **39.5 mm**
Predecessor model: **48.5 mm**

Polyester
Water repellent

Stand-up collar

DFJ210

With hood

DFJ211



Cotton
Water absorbency

Stand-up collar

DFJ310

With hood

DFJ311



Titanium-coated polyester
UV and IR reflection

Stand-up collar

DFJ410

With hood

DFJ411



Features



Mesh pocket for ice pack
DFJ210 / DFJ211
DFJ310 / DFJ311
DFJ410 / DFJ411



Hood with mesh ear design
DFJ210
DFJ410 / DFJ310



Stowaway hood
DFJ212



Pen pocket
DFJ210 / DFJ211
DFJ310 / DFJ311
DFJ410 / DFJ411
DFJ213



Arm pocket
DFJ212 / DFJ214



Loops for attaching safety pin
DFJ210 / DFJ211
DFJ310 / DFJ311
DFJ410 / DFJ411



Foldable sleeves
DFJ310 / DFJ311
DFJ410 / DFJ411

Comparison of body temperature rise during work

Skin temperature after a 10-minute work under temperature of 35°C and humidity of 60%

Never use the fan jacket where temperature reaches more than 50°C (122°F). Otherwise it may cause burns on your skin. Also avoid using in high humidity.

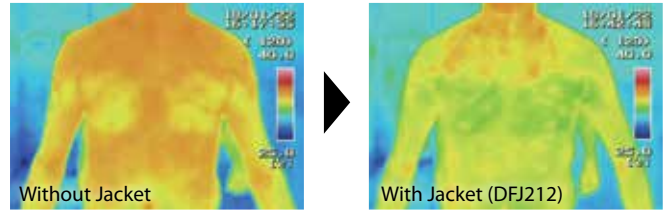
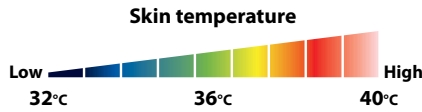

Circulate air throughout at the entire jacket

Close the zip fastener

Mainly ventilated at back of neck

Open the zip fastener

Well-balanced ventilation

■ DFJ212 ■ DFJ213 ■ DFJ214 ■ DFV210
■ DFJ210 / DFJ211 ■ DFJ310 / DFJ311 ■ DFJ410 / DFJ411

Use of high performance fabric to fit the various scenes

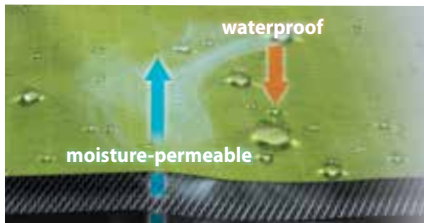

Moisture-permeable, waterproof fabric
water scarcely permeate even the water-resistant pressure of 1,000mm
■ DFJ212 ■ DFV210



Stretchable fabric
lightweight, stretchable, windproof comfortable to wear
■ DFJ213



Water-repellent, antistatic fabric
water-repellent and breathability make reduced in stuffy feeling
■ DFJ214

Polyester High-repellency fabric

Stand-up collar with stowaway hood
■ Casual type
DFJ212



Polyester Stretchable fabric

Stand-up collar Working wear type
DFJ213



Polyester Water repellency, antistatic fabric

Stand-up collar High-visibility type
DFJ214



Polyester High-repellency fabric

Stand-up collar Vest type
DFV210



Shoulder pads
■ DFJ410 / DFJ411



Insert supporting slider
■ DFJ212
■ DFV210



Velcro tabs for cuff adjustment
■ DFJ212



Drawcord on hem for adjustable fit
■ DFJ212
■ DFV210



Zip fastener with quick release function
■ DFJ213
■ DFJ214



Snap button and rubber shirring for hem adjustment
■ DFJ213
■ DFJ214



Antistatic material
■ DFJ214



Retroreflective material
■ DFJ214

Cordless Heated Jacket / Cordless Heated Vest

DCJ205 / DCJ206 / DCV202



HEATED JACKET and VEST

Heating effects

When wearing in a minus 5 degree C environment (in High mode)

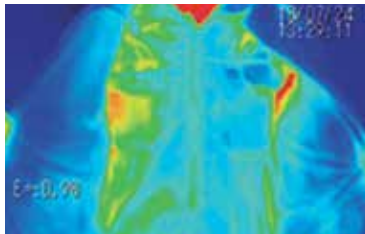

when switch is off

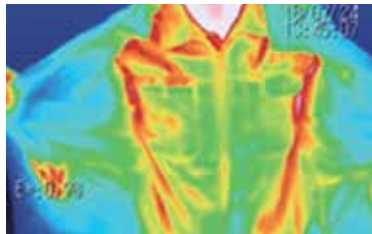

about 15 minutes after switch-on

3 Heat settings

Continuous runtime on a single full battery charge



Low		29h
Medium		11h
High		7h

with BL1850 (18V-5.0Ah Battery)

5 Heat zones ■ DCJ205 / CJ105D ■ DCJ206 / CJ106D

Left chest, right chest and back have each heating element.



4 Heat zones ■ DCV202 / CV102D

Left chest, right chest and back, neck have each heating element.



Wind and Water Resistance

prevents penetration of water such as light rain.



Fleece lining

warms a body even when switch is off



Washable and dryable

Detach the battery holder from the jacket or vest before washing.



■ Jacket type DCJ205 / CJ105D



■ High-visibility type DCJ206 / CJ106D



■ Vest type DCV202 / CV102D



Max run time

7.0h

Mode : High
Battery : BL1850B

Features



Battery pocket
■ DCJ205 / CJ105D
■ DCJ206 / CJ106D
■ DCV202 / CV102D



Two-way zip fastener
■ DCJ205 / CJ105D
■ DCJ206 / CJ106D
■ DCV202 / CV102D



Pen pocket
■ DCJ205 / CJ105D



Detachable hood
■ DCJ206 / CJ106D



Name tag holder
■ DCJ206 / CJ106D



Retroreflective material
■ DCJ206 / CJ106D

Jacket Size

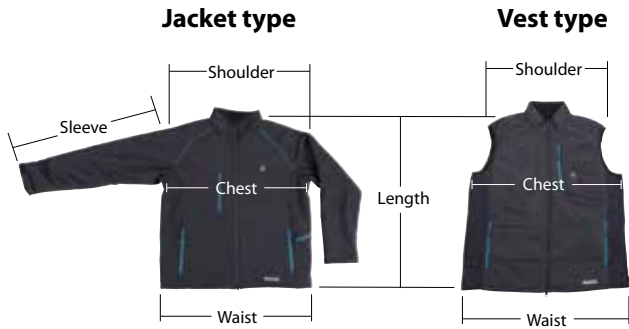

Heated Jacket Heated Vest

	size	S	M	L	XL	2XL	3XL
■ DCJ205 ■ DCJ206 DCJ205YM - Rs. 17,000 DCJ205YL / DCJ205YXL - Rs. 17,000 DCJ205Y2XL - Rs. 17,000 DCJ206YL - Rs. 20,000 DCJ206YXL - Rs. 20,000 DCJ206Y2XL - Rs. 20,000	Length	68	69	71	75	78	82
	Shoulder	50.5	52.5	54.5	55.5	56.5	57.5
	Sleeve	63	64.5	66	67	68	69
	Chest	108	118	128	138	146	156
	Waist	102	112	122	132	140	150
■ DCV202 DCV202YM - Rs. 13,000 DCV202YL - Rs. 13,000 DCV202YXL - Rs. 13,000 DCV202Y2XL - Rs. 13,000	Length	72	73	74	75	76	77
	Shoulder	47.5	49.5	51.5	53.5	55.5	57.5
	Chest	114	120	126	132	138	144
	Waist	116	122	128	134	140	146
	(in cm)						

Fan Jacket Fan Vest

	Asian Size / EU&US Size	S	M	L	XL	2XL	3XL
■ DFJ212 DFJ212ZL DFJ212ZM DFJ212ZXL	Length	62/66	64/68	66/70	68/71	70/72	72/73
	Shoulder	40/44	42/46	44/48	46/50	48/52	50/54
	Sleeve	79/87	82/90	85/93	88/95	91/97	92/99
	Chest	108/117	113/122	118/127	123/132	128/137	133/142
	Waist	102/111	107/116	112/121	117/126	122/131	127/136
■ DFJ213 DFJ213ZL DFJ213ZM DFJ213ZXL	Length	61/65	63/67	65/69	67/70	69/71	70/72
	Shoulder	43/47	45/49	47/51	49/53	51/55	53/57
	Sleeve	58/62	60/64	62/66	64/67	66/68	66/69
	Chest	109/117	114/122	119/127	124/132	129/137	134/142
	Waist	95~103/ 103~111	100~108/ 108~116	105~113/ 113~121	110~118/ 118~126	115~123/ 123~131	120~128/ 128~136
■ DFJ214 DFJ214ZL DFJ214ZM DFJ214ZXL	Length	64/68	66/70	68/72	70/73	72/74	73/75
	Shoulder	43/47	45/49	47/51	49/53	51/55	53/57
	Sleeve	58/62	60/64	62/66	64/67	66/68	66/69
	Chest	109/117	114/122	119/127	124/132	129/137	134/142
	Waist	95~103/ 103~111	100~108/ 108~116	105~113/ 113~121	110~118/ 118~126	115~123/ 123~131	120~128/ 128~136
■ DFJ210 / DFJ211 ■ DFJ310 / DFJ311 ■ DFJ410 / DFJ411	Length	62/68	64/70	66/72	68/74	70/76	72/78
	Shoulder	50/56.5	52/59	54/61.5	56/64	58/66.5	60/69
	Sleeve	52/58	54/60	56/62	58/64	60/66	62/68
■ DFV210 DFV210ZL DFV210ZM DFV210ZXL	Chest	114/126	118/131	122/136	126/141	130/146	134/151
	Waist	74~105/ 87~113	78~109/ 92~113	82~113/ 97~113	86~117/ 102~113	90~121/1 07~138	94~125/ 112~143
	Length	63/67	65/69	67/71	69/72	71/73	73/74
	Shoulder	39/43	41/45	43/47	45/49	47/51	49/53
	Chest	106/113	111/118	116/123	121/128	126/133	131/138
	Waist	100/107	105/112	110/117	115/122	120/127	125/132
(in cm)							

Longer continuous run time on a single full battery charge

Model No.	Battery holder	Li-ion Battery	Continuous run time Low / Medium / High	Net weight Jacket size L	Pockets
■ DFJ210 ■ DFJ211 ■ DFJ310 ■ DFJ311 ■ DFJ410 ■ DFJ411		18V 6.0Ah BL1860B 5.0Ah BL1850B 4.0Ah BL1840B 3.0Ah BL1830B 2.0Ah BL1820B 1.5Ah BL1815N	29 / 21 / 12 h with BL1850B	0.39kg (0.9 lbs.) 0.41kg (0.9 lbs.) 0.49kg (1.1 lbs.) 0.52kg (1.1 lbs.) 0.47kg (1.0 lbs.)	5
■ DFJ212 ■ DFJ213 ■ DFJ214 ■ DFV210		12V max 4.0Ah BL1041B 2.0Ah BL1021B 1.5Ah BL1016	13 / 9 / 5 h with BL1041B	0.49kg (1.1 lbs.) 0.43kg (0.9 lbs.) 0.54kg (1.2 lbs.) 0.54kg (1.2 lbs.) 0.38kg (0.8 lbs)	4 5 3
■ DCJ205 ■ DCJ206 ■ DCV202		18V 6.0Ah BL1860B 5.0Ah BL1850B 4.0Ah BL1840B 3.0Ah BL1830B 2.0Ah BL1820B 1.5Ah BL1815N	35 / 14 / 8.5 h with BL1860B 35 / 20 / 10 h with BL1860B	1.1kg (2.5 lbs.) 1.2kg (2.5 lbs.) 0.5kg (1.1 lbs.)	6 4
■ CJ105D ■ CJ106D ■ CV102D		12Vmax 4.0Ah BL1041B 2.0Ah BL1021B 1.5Ah BL1016	14 / 5.5 / 3.5 h with BL1041B 14 / 7.5 / 4 h with BL1041B	1.1kg (2.5 lbs.) 1.2kg (2.5 lbs.) 0.5kg (1.1 lbs.)	6 4

Net Weight : Jacket size L only

Cordless Heated Blanket

DCB200 18V / 14.4V LXT Li-Ion Heated Blanket
 CB100D 12V_{max} CXT Li-Ion Heated Blanket

Power button

To turn on the blanket, press and hold the power button for a few seconds. To turn off, press and hold the power button again.

Temperature adjustment

There are three temperature settings (high, medium, low)

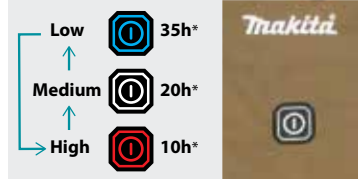

*Continuous runtime on a single full battery charge with BL1860B (18V-6.0Ah Battery)

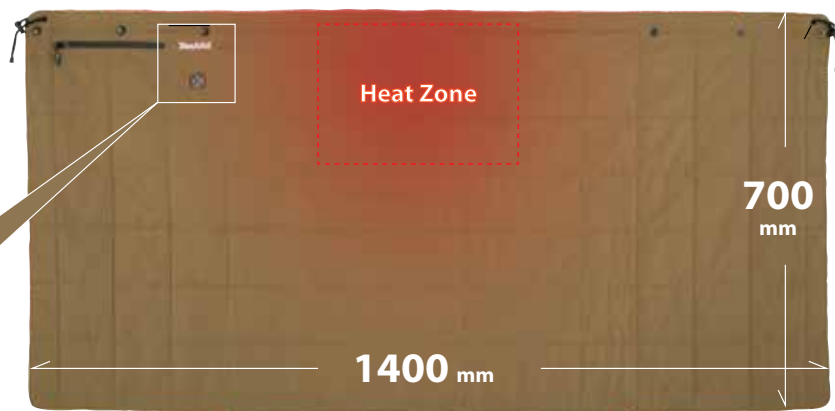

Battery pocket

The battery holder (with battery cartridge) can be stored in the battery pocket.



1.5m Extension cord



If you put the battery holder out of the battery pocket, connect the extension cord between the jack of the power cord and the plug of the battery holder.



3-in-1 versatile blanket

By fastening the snap buttons and strap on the blanket, you can use the blanket for warming up your shoulders and waist.



Machine-washable and machine-dryable

Be sure to remove the battery holder from the blanket before washing and drying.

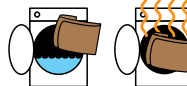

Longer continuous run time on a single full battery charge

Model No.	Battery holder	Li-ion Battery		Continuous run time Low / Medium / High
		18V	12V _{max}	
DCB200		6.0Ah BL1860B		35 / 20 / 10 h with BL1860B
		5.0Ah BL1850B		
		4.0Ah BL1840B		
		3.0Ah BL1830B		
		2.0Ah BL1820B		
		1.5Ah BL1815N		
CB100D		4.0Ah BL1041B		14 / 7.5 / 4 h with BL1041B
		2.0Ah BL1021B		
		1.5Ah BL1016		

DCB200 / CB100D

Cordless Heated Blanket



Standard Equipment:
 Battery Holder, Storage bag, 1.5m Extension cord

	DCB200	CB100D
Material	Outer: 100% Polyester / Batting: 100% Polyester / Liner: 100% Polyester	BL1041B: Low / Med / High: 14 / 7.5 / 4
Run Time (hrs)	BL1860B: Low / Med / High: 35 / 20 / 10	
Heat Zone	Upper Center: 1	Upper Center: 1
Heat Settings	High / Medium / Low	High / Medium / Low
Heat Value	High: 9.5 W Med: 4.5 W Low: 2.3 W	High: 9.5 W Med: 4.5 W Low: 2.3 W
Dimensions (L x W)	700x1,400 mm (27-1/2"x55")	700x1,400 mm (27-1/2"x55")
Net weight*	0.58 kg (1.28 lbs.)	0.58 kg (1.28 lbs.)

*Approximate weight without battery holder, battery cartridge, extension cord, and storage bag.

DCB200B
 CB100DB

18V

Cordless Cooler and Warmer Box
DCW180

new



Keep cold, Keep warm



Cooling capacity

-18°C ~ 10°C
[0°F ~ 50°F]

Five inside temperature settings

Warming capacity

55°C ~ 60°C
[130°F ~ 140°F]

Two inside temperature settings

Compatible with 3 power sources:



18V LXT battery (two in parallel or one)



AC (through AC adapter)



12V/24V DC (cigar socket)



Carrying handle



LED display



Shoulder belt

Long run time

Work amount on a single full battery charge (BL1860B x2)

-18°C [0°F]

5°C [40°F]

60°C [140°F]

about **5h**

about **17h**

about **4h**



IPX4 water resistance
when powered by battery



USB output port
Type A for DC5V/ 2.4A



Bottle opener
Conveniently located for opening glass bottles

DCW180

Cordless Cooler and Warmer Box

18V / 12V / 24V LXT Cordless Cooler & Warmer Box

new

- Powered by 3 sources: 18V LXT Li-Ion battery (two in parallel or one), 12V/24V DC (cigar socket), AC
- Compressor type cooling system provides excellent cooling capacity
- Cooling capacity: -18 to 10°C, with five inside temperature settings (-18 / -10 / 0 / 5 / 10°C)
- Warming capacity: Two inside temperature settings (55 / 60°C)
- Large 20 L capacity; Able to store up to four 2 L plastic bottles or twenty 500 mL plastic bottles



LXT

Shoulder Belt, AC Adaptor, Cigar Socket Cable

Capacity	20 L (5.3 gal)
Cooling Capacity	-18 / -10 / 0 / 5 / 10°C (0 / 15 / 30 / 40 / 50°F)
Warming Capacity	55 / 60°C (130 / 140°F)
Cord Length	AC Adapter / Cigar Socket Cable: 2 / 2.5 m (6.5 / 8.2 ft)
Dimensions (L x W x H)	623 x 341 x 371.5 mm (24-1/2 x 13-3/8 x 14-5/8")
Net weight	13.3 - 14.3 kg (29.3 - 32.0 lbs.)

10.8V
Lithium-ion



TW100D Cordless Impact Wrench
10.8V Li-Ion Cordless 3/8" (9.5 mm) 110 N-m (1,000 in.lbs.) Impact Wrench



Fastening Capacities	Standard Bolt: M8 - M12 (5/16" - 1/2") High Tensile Bolt: M6 - M10 (1/4" - 3/8")
Square Drive	9.5 mm (3/8")
No Load Speed (RPM)	0 - 2,300
Impacts Per Minute (IPM)	0 - 3,000
Max Fastening Torque	110 N-m (1,000 in.lbs.)
Vibration Level	Impact tightening of fasteners of the maximum capacity of the tool: 8.0 m/s ²
Sound Pressure Level	88 dB(A)
Sound Power Level	99 dB(A)
Dimensions (L x W x H)	163x54x178 mm (6-3/8"x2-1/8"x7")
Net weight	0.95 kg (2.1 lbs.)



TW100DWE



Battery, Charger



7.2V
Lithium-ion



10.8V / 7.8V / 3.6V
Cordless

DF012D Cordless Driver Drill

7.2V Li-Ion Cordless Two-Position 5 mm (3/16") 8 N-m (71 in.lbs.) Driver Drill



Capacity	Steel: 5 mm (3/16") Wood: 6 mm (1/4")
No Load Speed (RPM)	High: 650 Low: 200
Max Fastening Torque	Hard / Soft: 5.6 / 3.6 N-m (50 / 32 in.lbs.)
Max lock torque	8.0 N-m (71 in.lbs.)
Vibration Level	Drilling Into Metal: 2.5 m/s ² or less
Sound Pressure Level	70 dB(A) or less
Dimensions (L x W x H)	Pistol Style: 218x44x142 mm (8-5/8"x1-3/4"x5-5/8")
Dimensions (L x W)	Straight Style: 273x44 mm (10-3/4"x1-3/4")
Net weight	0.53 kg (1.2 lbs.)



DF012DSE

Phillips Bit, Battery, Charger

TD022D Cordless Impact Driver

7.2V Li-Ion Cordless Two-Position 25 N-m (220 in.lbs.) Impact Driver



Capacity	Machine Screw: M3 - M8 (1/8" - 5/16") Standard Bolt: M3 - M8 (1/8" - 5/16") High Tensile Bolt: M3 - M6 (1/8" - 1/4") Coarse thread (in length): 22 - 45 mm (7/8" - 1-3/4")
Hex Shank	6.35 mm (1/4")
No Load Speed (RPM)	0 - 2,450
Impacts Per Minute (IPM)	0 - 3,000
Max Fastening Torque	25 N-m (220 in.lbs.)
Vibration Level	Fastening Bolt: 7.0 m/s ²
Sound Pressure Level	85 dB(A)
Sound Power Level	96 dB(A)
Dimensions (L x W x H)	Straight Style: 282x42x52 mm (11-1/8"x1-5/8"x2-1/16") Pistol Style: 227x42x142 mm (8-15/16"x1-5/8"x5-5/8")
Net weight	0.55 - 0.56 kg (1.2 lbs.)



TD022DSE

Holster, Bit set, Battery, Charger

3.6V
Built-in Battery
Lithium-ion

DF001D In-Line Cordless Screwdriver
3.6V Li-Ion In-Line Cordless 6.0 N-m (53 in.lbs.) Screwdriver, Built-In Battery



Fastening Capacities	Wood Screw: ø3.8 x 32 mm (1/8" x 1-1/4")
No Load Speed (RPM)	220
Max Fastening Torque	Hard / Soft: 4.0 / 3.0 N-m (35 / 27 in.lbs.)
Max lock torque	6.0 N-m (53 in.lbs.)
Vibration Level	Screwdriving w/o Impact: 2.5 m/s ² or less
Sound Pressure Level	70 dB(A) or less
Charging Time (hours)	3 - 5
Dimensions (L x W x H)	Straight Style: 287x47x51 mm (11-1/4"x1-7/8"x2") Pistol Style: 205x47x51 mm (8-1/8"x1-7/8"x2")
Net weight	0.36 kg (0.79 lbs.)



DF001DW



Bit set (81 pcs), AC Adaptor, USB Cable

Drilling / Fastening



High Speed Drill

DP2010
6.5 mm (1/4")



Continuous rating input	370W
Capacity	Steel: 6.5 mm (1/4") Wood: 15 mm (9/16")
No Load Speed (RPM)	0-4,200
Dimensions (L x W x H)	209x64x175 mm (8-1/4"x2-1/2"x6-7/8")
Net weight	1.0 kg (2.2 lbs.)
Power supply cord	2.0 m (6.6 ft)

DP2010



2-Speed Drill

DP4010
13 mm (1/2")



Continuous rating input	720W
Capacity	Steel Hi: 8 mm (5/16") Steel Lo: 13 mm (1/2") Wood Hi: 25 mm (1") Wood Lo: (1-9/16") 40 mm
No Load Speed (RPM)	High: 0 - 2,900 Low: 0 - 1,200
Dimensions (L x W x H)	347x70x220 mm (13-5/8"x2-3/4"x8-5/8")
Net weight	2.3 kg (5.0 lbs.)
Power supply cord	2.5 m (8.2 ft)

DP4010



Diamond Core Drill

DBM230



Continuous rating input	2,500W
Capacity	Concrete (w/ Diamond Core Bit):
No Load Speed (RPM)	230 mm (9") 3rd: 1,700 2nd: 1,040 1st: 390
Net weight	37.5 kg (82.7 lbs.)

DBM230



Drilling Machine

TB131



Continuous rating input	250W
Capacity	Steel: 13 mm (1/2") Wood: 24 mm (15/16")
No Load Speed (RPM)	570, 890, 1,300, 1,900, 2,670 (50 Hz), 690, 1,070, 1,560, 2,280, 3,200(60 Hz)
Net weight	20 kg (44.1 lbs.)

TB131

Impact Driver

TD0101



Continuous rating input	230W
Capacity	Machine Screw: M4 - M8 (5/32" - 5/16") Standard Bolt: M5 - M14 (3/16" - 9/16") High Tensile Bolt: M5 - M10 (3/16" - 3/8") Coarse thread (in length): 22 - 90 mm (7/8" - 3-1/2") Driving Shank (Hex) 6.35 mm (1/4")
Impacts Per Minute (IPM)	0 - 3,200
No Load Speed (RPM)	0 - 3,600
Max Fastening Torque	100 N-m (74 ft.lbs.)
Dimensions (L x W x H)	184x67x192 mm (7-1/4"x2-5/8"x7-9/16")
Net weight	0.99 kg (2.2 lbs.)
Power supply cord	2.5 m (8.2 ft)

TD0101

Drill

6412
10 mm (3/8")



Continuous rating input	450W
Capacity	Steel: 10 mm (3/8") Wood: 25 mm (1")
No Load Speed (RPM)	0 - 3,400
Dimensions (L x W x H)	228x64x183 mm (9"x2-1/2"x7-1/4")
Net weight	1.3 kg (2.9 lbs.)
Power supply cord	2.0 m (6.6 ft)

6412

Angle Drill

DA3010F
10 mm (3/8")



Continuous rating input	450W
Capacity	Steel: 10 mm (3/8") Wood: 25 mm (1")
No Load Speed (RPM)	0-2,400
Overall Length	270 mm (10-5/8")
Net weight	1.6 kg (3.5 lbs.)
Power supply cord	2.5 m (8.2 ft)

DA3010F

Diamond Core Drill

DBM131
Wet & Dry



Continuous rating input	1,700W
Capacity	Concrete (w/ Diamond Core Bit) Hi: 70 mm (2-3/4") Concrete (w/ Diamond Core Bit) Lo: 132 mm (5-3/16")
Tool holder	(Spindle): M18
No Load Speed (RPM)	High: 0-2,300 Low: 0-1,100
Net weight	6.3 kg (13.9 lbs.)

DBM131

Screwdriver

FS2700



Dimensions: for countries providing noise suppressor

Continuous rating input	570W
Capacity	Self-Drilling Screw: 6 mm (1/4") Machine Screw: 8 mm (5/16") Wood Screw: 6.2 mm (1/4")
Driving Shank (Hex)	6.35 mm (1/4")
No Load Speed (RPM)	0 - 2,500
Vibration Level	Screwdriving w/o Impact: 2.5 m/s ² or less
Sound Pressure Level	83 dB(A)
Sound Power Level	94 dB(A)
Dimensions (L x W x H)	301x70x207 mm (11-7/8"x2-3/4"x8-1/8")
Net weight	1.8 kg (4 lbs.)
Power supply cord	2.5 m (8.2 ft)

FS2700

Impact Wrench

TW0350
1/2" (12.7 mm)



Continuous rating input	400W
Fastening Capacities	Standard Bolt: M12 - M22 (1/2" - 7/8") High Tensile Bolt: M12 - M16 (1/2" - 5/8") Square Drive 12.7 mm (1/2")
No Load Speed (RPM)	2,000
Impacts Per Minute (IPM)	2,000
Max Fastening Torque	350 N-m (260 ft.lbs.)
Vibration Level	Impact tightening of fasteners of the maximum capacity of the tool: 11.5 m/s ²
Sound Pressure Level	93 dB(A)
Sound Power Level	104 dB(A)
Dimensions (L x W x H)	283x87x233 mm (11-1/8"x3-7/16"x9-1/8")
Net weight	3 kg (6.6 lbs.)
Power supply cord	2.5 m (8.2 ft)

TW0350

Impact Wrench



Impact Wrench

411 W

TW0200
1/2" (12.7 mm)



TW0200

Continuous rating input	380W
Fastening Capacities	
Standard Bolt:	M10 - M16 (3/8" - 5/8")
High Tensile Bolt:	M10 - M12 (3/8" - 1/2")
Square Drive	12.7 mm (1/2")
No Load Speed (RPM)	0 - 2,200
Impacts Per Minute (IPM)	0 - 2,200
Max Fastening Torque	200 N-m (150 ft.lbs.)
Vibration Level	Impact tightening of fasteners of the maximum capacity of the tool:
	8.5 m/s ²
Sound Pressure Level	93 dB(A)
Sound Power Level	104 dB(A)
Dimensions (L x W x H)	251 x 72 x 220 mm (9-7/8" x 2-13/16" x 8-5/8")
Net weight	2.1 kg (4.7 lbs.)
Power supply cord	2.5 m (8.2 ft)

Impact Wrench

100 W

6906
3/4" (19 mm)



Continuous rating input	850W
Capacity	
Standard Bolt:	M16 - M22 (5/8" - 7/8")
High Tensile Bolt:	M16 - M20 (5/8" - 3/4")
Square Drive	19 mm (3/4")
No Load Speed (RPM)	1,700
Impacts Per Minute (IPM)	1,600
Max Fastening Torque	588 N-m (441 ft.lbs.)
Vibration Level	Impact tightening of fasteners of the maximum capacity of the tool: 16.5 m/s ²
Sound Pressure Level	98 dB(A)
Sound Power Level	109 dB(A)
Overall Length	327 mm (12-7/8")
Net weight	5.6 kg (12.2 lbs.)
Power supply cord	2.5 m (8.2 ft)

6906

Impact Wrench

153 W

TW1000
1" (25.4 mm)



TW1000

Continuous rating input	1,200W
Fastening Capacities	
Standard Bolt:	M24 - M30 (1 1/16" - 1-3/16")
High Tensile Bolt:	M22 - M24 (7/8" - 15/16")
Square Drive	25.4 mm (1")
No Load Speed (RPM)	1,400
Impacts Per Minute (IPM)	1,500
Max Fastening Torque	1,000 N-m (738 ft.lbs.)
Vibration Level	Impact tightening of fasteners of the maximum capacity of the tool: 17.5 m/s ²
Sound Pressure Level	103 dB(A)
Sound Power Level	114 dB(A)
Dimensions (L x W x H)	382 x 110 x 290 mm (15" x 4-5/16" x 11-3/8")
Net weight	8.8 kg (19.4 lbs.)
Power supply cord	2.5 m (8.2 ft)

Shear Wrench

303 W

6924N
M22(7/8"), M24(1"), SHTB22



Continuous rating input	1,050W
Capacity	Bolt : M22, M24, 7/8", 1"
	Super high tensile bolt: M22
No Load Speed (RPM)	19
Max Fastening Torque	1,100 N-m (810 ft.lbs.)
Dimensions (L x W x H)	330 x 104 x 257 mm (13" x 4-1/8" x 10-1/8")
Net weight	7.5 kg (16.6 lbs.)
Power supply cord	2.5 m (8.2 ft)

6924N

Magnetic Drill

HB500
50 mm (2")



Capacity	Steel: 50 mm (2")
Chuck capacity	16 mm (5/8")
No Load Speed (RPM)	350 / 650
Magnetic clamping force	Minimum 9,300N (950kg)
Dimensions (L x W x H)	290 x 150 x 450 mm (11-3/8" x 5-7/8" x 17-3/4")
Net weight	18.5 kg (40.8 lbs.)

HB500

Shear Wrench

411 W

6922NB
M16 (5/8"), M20 (3/4"), M22 (7/8")



Continuous rating input	1,330W
Capacity	Bolt : M16, M20, M22 (5/8", 3/4", 7/8")
No Load Speed (RPM)	18
Max Fastening Torque	804 N-m (593 ft.lbs.)
Dimensions (L x W x H)	249 x 84 x 252 mm (9-13/16" x 3-5/16" x 9-15/16")
Net weight	4.9 kg (10.8 lbs.)
Power supply cord	2.5 m (8.2 ft)

6922NB

Impact Drilling / Demolition



Hammer Drill

85 W

HP1630
16 mm (5/8")



Continuous rating input	710W
Capacity	Concrete: 16 mm (5/8") Steel: 13 mm (1/2") Wood: 30 mm (1-3/16")
No Load Speed (RPM)	0 - 3,200
Impacts Per Minute (IPM)	0 - 48,000
Vibration Level	Hammer Drilling into Concrete: 17.0 m/s ² Drilling Into Metal: 2.5 m/s ²
Sound Pressure Level	97 dB(A)
Sound Power Level	108 dB(A)
Dimensions (L x W x H)	296 x 75 x 204 mm (11-5/8" x 2-15/16" x 8")
Net weight	2.1 kg (4.6 lbs.)
Power supply cord	2.0 m (6.6 ft)

HP1630

2-Speed Hammer Drill

419 W

HP2070
20 mm (3/4")



Continuous rating input	1,010W
Capacity	Concrete: 20 mm (3/4") Steel Hi: 8 mm (5/16") Steel Lo: 16 mm (5/8") Wood Hi: 25 mm (1") Wood Lo: 40 mm (1-9/16")
Impacts Per Minute (IPM)	High: 0-58,000 Low: 0-24,000
No Load Speed (RPM)	High: 0-2,900 Low: 0-1,200
Overall Length	364 mm (14-3/8")
Net weight	2.6 kg (5.7 lbs.)
Power supply cord	2.5 m (8.2 ft)

HP2070

Rotary Hammer

459 W

HR1840
18 mm (11/16") Adapted for SDS-PLUS bits

2-mode



Continuous rating input	470W
Impact Energy	EPTA-Procedure 05/2009: 1.4 J
Capacity	Concrete: 18 mm (11/16") Steel: 13 mm (1/2") Wood: 24 mm (15/16")
Blows Per Minute (BPM)	0 - 4,800
No Load Speed (RPM)	0 - 2,100
Sound Pressure Level	87 dB(A)
Sound Power Level	98 dB(A)
Vibration Level	Hammer Drilling into Concrete: 10.0 m/s ² Drilling Into Metal: 3.0 m/s ²
Dimensions (L x W x H)	285 x 75 x 208 mm (11-1/4" x 3" x 8-3/16")
Net weight	2.0 - 2.4 kg (4.3 - 5.3 lbs.)
Power supply cord	2.5 m (8.2 ft)

HR1840

Rotary Hammer

325 W

HR2230
22 mm (7/8") Adapted for SDS-PLUS bits

2-mode



Continuous rating input	710W
Impact Energy	EPTA-Procedure 05/2009: 2.2 J
Capacity	Concrete (w/ Core Bit): 54 mm (2-1/8") Steel: 13 mm (1/2") Wood: 32 mm (1-1/4")
Blows Per Minute (BPM)	0 - 4,050
No Load Speed (RPM)	0 - 1,050
Sound Pressure Level	89 dB(A)
Sound Power Level	100 dB(A)
Vibration Level	Hammer Drilling into Concrete: 15 m/s ²
Dimensions (L x W x H)	357 x 84 x 214 mm (14" x 3-5/16" x 8-3/8")
Net weight	2.6 - 3.1 kg (5.8 - 6.8 lbs.)
Power supply cord	2.5 m (8.2 ft)

HR2230

Rotary Hammer

325 W

HR2020
20 mm (3/4") Adapted for SDS-PLUS bits

2-mode



Continuous rating input	710W
Impact Energy	EPTA-Procedure 05/2009: 2.2 J
Capacity	Concrete: 20 mm (3/4") Steel: 13 mm (1/2") Wood: 32 mm (1-1/4")
Blows Per Minute (BPM)	0 - 4,050
No Load Speed (RPM)	0 - 1,050
Sound Pressure Level	89 dB(A)
Sound Power Level	100 dB(A)
Vibration Level	Hammer Drilling into Concrete: 15 m/s ²
Net weight	2.3 kg (5.1 lbs.)
Power supply cord	4.0 m (13.1 ft)

HR2020

Driver Drill & Hammer Driver Drill

DF0300 / HP0300 10 mm (3/8") 320 W Driver Drill with Keyless Chuck

Compact overall length
DF0300: 220mm, HP0300: 235mm

2 sleeve keyless Drill chuck
allows for easy bit installation/
removal by one hand.

Capacity of drill chuck
1.0 - 10 mm (1/32 - 3/8")

20 Torque settings



Variable speed control by trigger

Mechanical 2-speed gearing
High / Low: 0 - 1,500 / 0 - 450



Ergonomic handle with soft grip for driver-drill applications



Driver Drill
DF0300



Accessory

Hook set
Part No.
194759-0



Bit holder
Part No.
452947-8

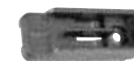

Driver Drill	DF0300 10 mm (3/8")
Hammer Driver Drill	HP0300 10 mm (3/8")

DF0300
HP0300

	DF0300	HP0300
Double Insulation		
Variable Speed		
Reversing		
Mechanical 2-Speed		
Keyless Chuck		
Torque Setting 20		
Continuous rating input	320W	320W
Capacity	Steel / Wood: 10 / 28mm (3/8" / 1-1/8")	Concrete / Steel / Wood: 8 / 10 / 28mm (5/16" / 3/8" / 1-1/8")
Chuck Capacity	1.0 - 10 mm (1/32 - 3/8")	1.0 - 10 mm (1/32 - 3/8")
No Load Speed (RPM)	High / Low: 0 - 1,500 / 0 - 450	High / Low: 0 - 1,500 / 0 - 450
Blows Per Minute (BPM)	-	High / Low: 0 - 22,500 / 0 - 6,750
Max Fastening Torque	Hard / Soft: 56.0 / 21.0 N·m (500 / 190 in.lbs.)	Hard / Soft: 56.0 / 21.0 N·m (500 / 190 in.lbs.)
Max lock torque	42.0 N·m (370 in.lbs.)	42.0 N·m (370 in.lbs.)
Vibration Level	2.5 m/s ² or less	Impact Drilling into Concrete: 12.5 m/s ² Drilling into Metal: 2.5 m/s ² or less
Sound Pressure Level	80 dB(A)	82 dB(A)
Sound Power Level	91 dB(A)	93 dB(A)
Dimensions (L x W x H)	220x67x206 mm (8-5/8"x2-5/8"x8-1/8")	235x67x206 mm (9-1/4"x2-5/8"x8-1/8")
Net weight	1.2 kg (2.7 lbs.)	1.3 kg (2.8 lbs.)
Power supply cord	2.5 m (8.2 ft)	2.5 m (8.2 ft)

Standard Equipment : Bit

AVT & SOFT NO LOAD

ANTI VIBRATION TECHNOLOGY

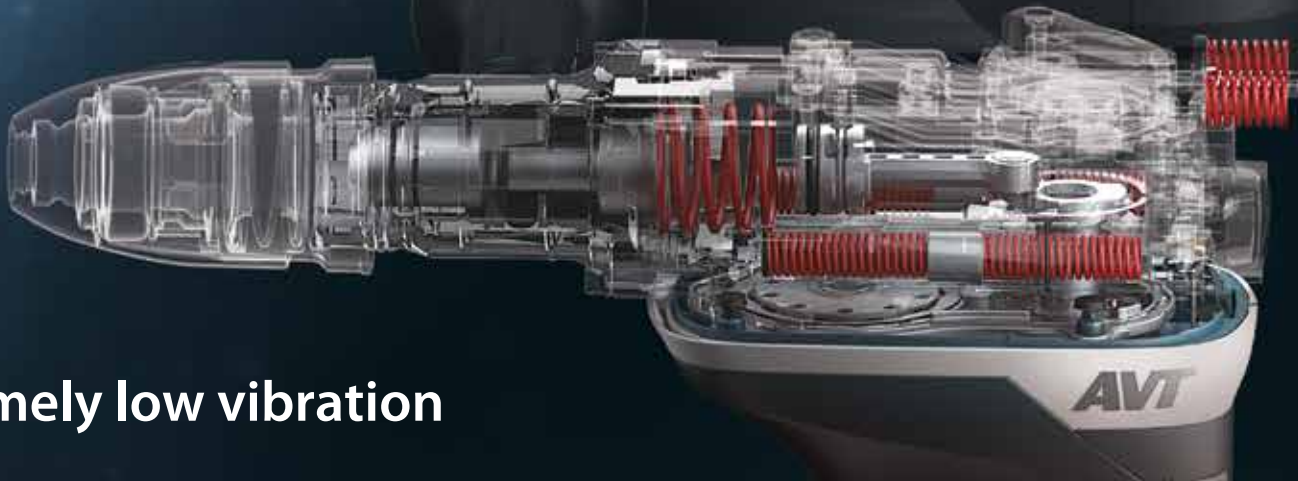

Extremely low vibration

AVT
ANTI VIBRATION TECHNOLOGY
&
SOFT NO LOAD

50mm
Rotary Hammer
HR5212C



40mm
Rotary Hammer
HR4013C



Demolition Hammer
HM0871C



Demolition Hammer
HM1111C
HM1213C



Demolition Hammer
HM1214C



Electric Breaker
HM1317C
HM1317CB
HM1812



26mm
Combination Hammer with
Self Dust Collection
HR2653



26mm
Combination Hammer with
Self Dust Collection
HR2663



26mm
Combination Hammer with
Self Dust Collection
HR2653T



18mm
Rotary Hammer
HR1841F



26mm
Combination Hammer
HR2641



26mm
Combination Hammer
HR2631FT / HR2631F



Rotary Hammer
HR2601



32mm
Combination Hammer
HR3210FCT / HR3210C



35mm
Combination Hammer
HR3541FC



40mm
Rotary Hammer
HR4013C



45mm
Rotary Hammer
HR4511C / HR4510C



52mm
Rotary Hammer
HR5212C



AVT
ANTI VIBRATION TECHNOLOGY

Rotary Hammer

350

HR4002
40 mm (1-9/16") Adapted for SDS-MAX bits
2-mode



Continuous rating input	1,050W
Impact Energy	EPTA-Procedure 05/2009: 6.1 J
Capacity	Concrete (w/ TCT Bit): 40 mm (1-9/16") Concrete (w/ Core Bit): 105 mm (4-1/8")
Blows Per Minute (BPM)	2,500
No Load Speed (RPM)	680
Sound Pressure Level	92 dB(A)
Sound Power Level	103 dB(A)
Vibration Level	Hammer Drilling into Concrete: 17.5 m/s ²
Dimensions (L x W x H)	458x114x256 mm (18"x4-1/2"x10-1/8")
Net weight	6.6 - 6.8 kg (14.6 - 15.0 lbs.)
Power supply cord	5.0 m (16.4 ft)

HR4002

Rotary Hammer

175

HR5202C
52 mm (2-1/16") Adapted for SDS-MAX bits
2-mode



Continuous rating input	1,510W
Impact Energy	EPTA-Procedure 05/2009: 19.1 J
Capacity	Concrete (w/ TCT Bit): 52 mm (2") Concrete (w/ Core Bit): 160 mm (6-5/16")
Blows Per Minute (BPM)	1,100 - 2,250
No Load Speed (RPM)	150 - 310
Sound Pressure Level	99 dB(A)
Sound Power Level	110 dB(A)
Vibration Level	Hammer Drilling into Concrete: 17.0 m/s ²
Dimensions (L x W x H)	599x134x287 mm (23-1/2"x5-1/4"x11-1/4")
Net weight	10.9 - 11.1 kg (24.1 - 24.4 lbs.)
Power supply cord	5.0 m (16.4 ft)

HR5202C

Combination Hammer

325

HR2470
24 mm (15/16"), Adapted for SDS-PLUS bits
3-mode



Continuous rating input	780W
Impact Energy	EPTA-Procedure 05/2009: 2.4 J
Capacity	Concrete: 24 mm (15/16") Steel: 13 mm (1/2") Wood: 32 mm (1-1/4")
Blows Per Minute (BPM)	0 - 4,500
No Load Speed (RPM)	0 - 1,100
Sound Pressure Level	90 dB(A)
Sound Power Level	101 dB(A)
Vibration Level	Hammer Drilling into Concrete: 15.5 m/s ² Drilling Into Metal: 4.5 m/s ²
Dimensions (L x W x H)	370x84x214 mm (14-1/2"x3-5/16"x8-3/8")
Net weight	2.9 - 3.3 kg (6.4 - 7.3 lbs.)
Power supply cord	4.0 m (13.1 ft)

HR2470

Combination Hammer with Self Dust Collection

325

HR2650 26 mm (1"), Adapted for SDS-PLUS bits
3-mode



Continuous rating input	800W
Impact Energy	EPTA-Procedure 05/2009: 2.2 J
Capacity	Concrete: 26 mm (1") Core Bit: 68 mm (2-11/16") Diamond Core Bit (Dry Type): 80 mm (3-1/8") Steel: 13 mm (1/2") Wood: 32 mm (1-1/4")
Blows Per Minute (BPM)	0 - 4,600
No Load Speed (RPM)	0 - 1,200
Sound Pressure Level	90 dB(A)
Sound Power Level	101 dB(A)
Vibration Level	Drilling into Metal: 2.5 m/s ²
Dimensions (L x W x H)	604x89x228 mm (23-3/4"x3-1/2"x9")
Net weight	3.0 - 4.1 kg (6.7 - 9.1 lbs.)
Power supply cord	2.5 m (8.2 ft)

HR2650

Rotary Hammer

350

HR4013C
40 mm (1-9/16") Adapted for SDS-MAX bits
2-mode



Continuous rating input	1,100W
Impact Energy	EPTA-Procedure 05/2009: 8 J
Capacity	Concrete (w/ TCT Bit): 40 mm (1-9/16") Concrete (w/ Core Bit): 105 mm (4-1/8")
Blows Per Minute (BPM)	1,450 - 2,900
No Load Speed (RPM)	250 - 500
Sound Pressure Level	92 dB(A)
Sound Power Level	103 dB(A)
Vibration Level	Hammer Drilling into Concrete: 5.0 m/s ²
Dimensions (L x W x H)	479x112x263 mm (18-11/16"x4-3/8"x10-3/8")
Net weight	6.8 - 6.9 kg (14.9 - 15.3 lbs.)
Power supply cord	5.0 m (16.4 ft)

HR4013C

Rotary Hammer

175

HR5212C
52 mm (2-1/16") Adapted for SDS-MAX bits
2-mode



Continuous rating input	1,510W
Impact Energy	EPTA-Procedure 05/2009: 20 J
Capacity	Concrete (w/ TCT Bit): 52 mm (2") Concrete (w/ Core Bit): 160 mm (6-5/16")
Blows Per Minute (BPM)	1,100 - 2,250
No Load Speed (RPM)	150 - 310
Sound Pressure Level	98 dB(A)
Sound Power Level	109 dB(A)
Vibration Level	Hammer Drilling into Concrete: 9.0 m/s ²
Dimensions (L x W x H)	599x140x287 mm (23-1/2"x5-1/2"x11-1/4")
Net weight	11.9 - 12.0 kg (26.2 - 26.5 lbs.)
Power supply cord	5.0 m (16.4 ft)

HR5212C



Combination Hammer

325

HR2630
26 mm (1"), Adapted for SDS-PLUS bits
3-mode



Continuous rating input	800W
Impact Energy	EPTA-Procedure 05/2009: 2.4 J
Capacity	Concrete: 26 mm (1") Steel: 13 mm (1/2") Wood: 32 mm (1-1/4")
Blows Per Minute (BPM)	0 - 4,600
No Load Speed (RPM)	0 - 1,200
Sound Pressure Level	90 dB(A)
Sound Power Level	101 dB(A)
Vibration Level	Hammer Drilling into Concrete: 15.0 m/s ²
Dimensions (L x W x H)	385x77x209 mm (15-1/8"x3"x8-1/4")
Net weight	2.8 - 3.3 kg (6.3 - 7.2 lbs.)
Power supply cord	2.5 m (8.2 ft)

HR2630

Combination Hammer

325

HR2810
28 mm (1-1/8") Adapted for SDS-PLUS bits
3-mode



Continuous rating input	800W
Impact Energy	EPTA-Procedure 05/2009: 2.8 J
Capacity	Concrete (w/ TCT Bit): 28 mm (1-1/8") Steel: 13 mm (1/2") Wood: 32 mm (1-1/4")
Blows Per Minute (BPM)	0 - 4,500
No Load Speed (RPM)	0 - 1,100
Sound Pressure Level	89 dB(A)
Sound Power Level	100 dB(A)
Vibration Level	Hammer Drilling into Concrete: 20 m/s ²
Dimensions (L x W x H)	314x89x225 mm (12-3/8"x3-1/2"x8-7/8")
Net weight	3.4 - 3.8 kg (7.5 - 8.5 lbs.)
Power supply cord	2.5 m (8.2 ft)

HR2810

Rotary Hammer

350

HR4003C
40 mm (1-9/16") Adapted for SDS-MAX bits
2-mode



Continuous rating input	1,100W
Impact Energy	EPTA-Procedure 05/2009: 8.3 J
Capacity	Concrete (w/ TCT Bit): 40 mm (1-9/16") Concrete (w/ Core Bit): 105 mm (4-1/8")
Blows Per Minute (BPM)	1,450 - 2,900
No Load Speed (RPM)	250 - 500
Sound Pressure Level	92 dB(A)
Sound Power Level	103 dB(A)
Vibration Level	Hammer Drilling into Concrete: 10.0 m/s ²
Dimensions (L x W x H)	479x106x263 mm (18-11/16"x4-3/16"x10-3/8")
Net weight	6.2 - 6.4 kg (13.7 - 14.1 lbs.)
Power supply cord	5.0 m (16.4 ft)

HR4003C

- Rs. 60,800

Impact Drilling
Demolition

Product Comparison List

Rotary Hammer & Combination Hammer

*with Dust Extraction

Model No.	Type	Capacity (mm)	Continuous rating Input (W)	Impact energy (J)		Net weight (kg)	AVT	Soft No load	Built-in Job Light	Quick change
				EPTA-Procedure 05/2009	Makita standard					
SDS-PLUS Shank										
HR1841F/ HR1840	Rotary	18	470	1.4	1.4	2.0 - 2.5 kg (4.5 - 5.4 lbs)	•/-		•/-	
HR2230	Rotary	22	710	2.2	2.3	2.6 - 3.1 kg (5.8 - 6.8 lbs)				
HR2320T	Combination	23	720	2.3	2.3	2.9 - 3.2 kg (6.4 - 7.0 lbs)				•
HR2300	Rotary	23	720	2.3	2.3	2.7 - 3.1 kg (5.9 - 6.9 lbs)				
HR2470FT	Combination	24	780	2.4	2.7	3.0 - 3.3 kg (6.7 - 7.3 lbs)			•	•
HR2470T	Combination	24	780	2.4	2.7	3.0 - 3.3 kg (6.7 - 7.3 lbs)				•
HR2470/F	Combination	24	780	2.4	2.7	2.9 - 3.3 kg (6.4 - 7.3 lbs)			-/•	
HR2460/F	Rotary	24	780	2.4	2.7	2.8 - 3.2 kg (6.1 - 7.0 lbs)			-/•	
HR2475(D handle)	Combination	24	780	2.3	2.7	3.0 - 3.4 kg (6.6 - 7.6 lbs)				
*HR2653T	Combination	26	800	2.2	2.9	3.2 - 4.5 kg (7.2 - 9.9 lbs.)	•			•
*HR2653	Combination	26	800	2.2	2.9	3.1 - 4.3 kg (6.9 - 9.6 lbs.)	•			
*HR2652	Combination	26	800	2.2	2.9	3.0 - 4.3 kg (6.7 - 9.4 lbs.)				
*HR2663(D handle)	Combination	26	800	2.2	2.9	3.3 - 4.6 kg (7.3 - 10.0 lbs.)	•			
HR2641(D handle)	Combination	26	800	2.4	2.9	3.1 - 3.5 kg (6.8 - 7.8 lbs)	•			
HR2631FT	Combination	26	800	2.4	2.9	3.1 - 3.6 kg (6.8 - 7.9 lbs)	•		•	•
HR2631F	Combination	26	800	2.4	2.9	2.9 - 3.4 kg (6.4 - 7.4 lbs)	•		•	
HR2630T	Combination	26	800	2.4	2.9	3.0 - 3.5 kg (6.6 - 7.7 lbs)				•
HR2630	Combination	26	800	2.4	2.9	2.8 - 3.3 kg (6.3 - 7.2 lbs)				
HR2601	Rotary	26	800	2.4	2.9	3.1 - 3.6 kg (6.9 - 7.8 lbs)	•			
HR2600	Rotary	26	800	2.4	2.9	3.0 - 3.4 kg (6.5 - 7.5 lbs)				
HR2811FT	Combination	28	800	2.9	2.9	3.6 - 3.9 kg (8.0 - 8.6 lbs)			•	•
HR2811F	Combination	28	800	2.8	2.9	3.5 - 3.9 kg (7.7 - 8.7 lbs)			•	
HR2810T	Combination	28	800	2.9	2.9	3.5 - 3.8 kg (7.8 - 8.4 lbs)				•
HR2810	Combination	28	800	2.8	2.9	3.4 - 3.8 kg (7.5 - 8.5 lbs)				
HR2800	Rotary	28	800	2.8	2.9	3.4 - 3.8 kg (7.4 - 8.4 lbs)				
HR3210FCT	Combination	32	850	4.9	5.5	5.4 - 5.6 kg (11.9 - 12.3 lbs)	•		•	•
HR3210C	Rotary	32	850	5	5.5	5.2 - 5.6 kg (11.4 - 12.4 lbs)	•			
17mm Hex Shank										
HR3530	Rotary	35	1,010	-	6.2	5.8 kg (12.8 lbs)				
HR4030C	Rotary	40	1,100	-	9.2	6.9 kg (15.2 lbs)				
19mm Hex Shank Spline Shank										
HR4041C	Rotary	40	1,100		9.2	6.7 kg (14.8 lbs)				
HR5000	Rotary	50	1,200	11.3	11.8	9.9 kg (21.8 lbs)				
SDS-MAX Shank										
HR3541FC	Combination	35	850	5.7	6.3	5.6 - 5.7 kg (12.3 - 12.6 lbs)	•		•	
HR3540C	Combination	35	850	5.6	6.3	5.2 - 5.3 kg (11.4 - 11.6 lbs)				
HR4013C	Rotary	40	1,100	8	11.4	6.8 - 6.9 kg (14.9 - 15.3 lbs)	•	•		
HR4003C	Rotary	40	1,100	8.3	11.4	6.2 - 6.4 kg (13.7 - 14.1 lbs)				
HR4002	Rotary	40	1,050	6.1	6.2	6.6 - 6.8 kg (14.6 - 15.0 lbs)				
HR4511C	Rotary	45	1,350	9.4	12.5	9.0 - 9.1 kg (19.8 - 20.1 lbs)	•			
HR4510C	Rotary	45	1,350	9.4	12.5	8.9 - 9.0 kg (19.5 - 19.9 lbs)	•			
HR4501C	Rotary	45	1,350	10.1	12.5	8.2 - 8.4 kg (18.1 - 18.5 lbs)				
HR5212C	Rotary	52	1,510	20	21	11.9 - 12.0 kg (26.2 - 26.5 lbs)	•	•		
HR5202C	Rotary	52	1,510	19.1	21	10.9 - 11.1 kg (24.1 - 24.4 lbs)				

Demolition Hammer

105

HM0810T
11/16" : 17 mm Hex Shank



Continuous rating input	900W
Impact Energy	EPTA-Procedure 05/2009: 7.2 J
Blows Per Minute (BPM)	2,900
Sound Pressure Level	92 dB(A)
Sound Power Level	103 dB(A)
Overall Length	428 mm (16-7/8")
Net weight	6.3 kg (13.9 lbs.)
Power supply cord	5.0 m (16.4 ft)

HM0810TA

Demolition Hammer

350

HM0870C
Adapted for SDS-MAX bits



Continuous rating input	1,100W
Impact Energy	EPTA-Procedure 05/2009: 7.6 J
Blows Per Minute (BPM)	1,100 - 2,650
Sound Pressure Level	87 dB(A)
Sound Power Level	98 dB(A)
Dimensions (L x W x H)	449x109x230 mm (17-3/4"x4-1/4"x9")
Net weight	5.1 - 5.3 kg (11.1 - 11.6 lbs.)
Power supply cord	5.0 m (16.4 ft)

HM0870C

Demolition Hammer

175

HM1213C
Adapted for SDS-MAX bits



Continuous rating input	1,510W
Impact Energy	EPTA-Procedure 05/2009: 18.6 J
Blows Per Minute (BPM)	950 - 1,900
Sound Pressure Level	75 dB(A)
Sound Power Level	95 dB(A)
Dimensions (L x W x H)	576x149x265 mm (22-3/4"x5-7/8"x10-3/8")
Net weight	10.8 kg (23.7 lbs.)
Power supply cord	5.0 m (16.4 ft)

HM1213C

Demolition Hammer

204

HM1306
1-3/16" : 30 mm Hex Shank



Continuous rating input	1,510W
Impact Energy	EPTA-Procedure 05/2009: 21.7 J
Blows Per Minute (BPM)	1,450
Dimensions (L x W x H)	652x121x231 mm (25-3/4"x4-3/4"x9-1/8")
Net weight	15.1 kg (33.3 lbs.)
Power supply cord	5.0 m (16.4 ft)

HM1306

Electric Breaker

HM1812
1-1/8" : 28.6 mm Hex shank



Continuous rating input	2,000W
Impact Energy	EPTA-Procedure 05/2009: 72.8 J
Blows Per Minute (BPM)	870
Sound Pressure Level	96 dB(A)
Sound Power Level	107 dB(A)
Dimensions (L x W x H)	843x210x608 mm (33-1/4"x8-1/4"x24")
Net weight	31.3 kg (69 lbs.)
Power supply cord	5.0 m (16.4 ft)

HM1812

Demolition Hammer

175

HM1205C
Adapted for SDS-MAX bits



Continuous rating input	1,510W
Impact Energy	EPTA-Procedure 05/2009: 19.1 J
Blows Per Minute (BPM)	950 - 1,900
Sound Pressure Level	79 dB(A)
Sound Power Level	93 dB(A)
Dimensions (L x W x H)	576x128x265 mm (22-3/4"x5"x10-3/8")
Net weight	9.7 kg (21.5 lbs.)
Power supply cord	5.0 m (16.4 ft)

HM1205C



Power Scraper

350

HK1820
Adapted for SDS-PLUS bits



Continuous rating input	550W
Impact Energy	EPTA-Procedure 05/2009: 3.1 J
Blows Per Minute (BPM)	0 - 3,200
Dimensions (L x W x H)	351x102x203 mm (13-3/4"x4"x8")
Net weight	3.4 kg (7.5 lbs.)
Power supply cord	5.0 m (16.4 ft)

HK1820

Product Comparison List

Model No.	Continuous rating Input (W)	Impact energy (J)		Net weight	AVT	Soft No load
		EPTA-Procedure 05/2009	Makita standard			

Demolition Hammer, Electric Breaker

17mm Hex Shank

HM0810	900		7.6	6.7 kg (14.7 lbs)		
HM0810T	900	7.2	7.6	6.3 kg (13.9 lbs)		
HM0830	1,010		8.3	4.9 kg (10.7 lbs)		
HM0830T	1,010	7.2	8.3	4.8 kg (10.6 lbs)		

19mm Hex Shank

HM0810B	420	5.3	7.6	6.6 kg (14.5 lbs)		
---------	-----	-----	-----	-------------------	--	--

21mm Hex Shank

HM1201	1,130		13	9.1 kg (20.1 lbs)		
--------	-------	--	----	-------------------	--	--

SDS-MAX Shank

HM0871C	1,100	8.1	11.6	5.6 - 5.8 kg (12.4 - 12.8 lbs)	●	●
HM0870C	1,100	7.6	11.4	5.1 - 5.3 kg (11.1 - 11.6 lbs)		
HM1111C	1,300	11.2	17.2	7.8 - 8.0 kg (17.3 - 17.6 lbs)	●	●
HM1101C	1,300	11.5	17.2	7.2 - 7.3 kg (15.8 - 16.1 lbs)		
HM1213C	1,510	18.6	25.5	10.8 kg (23.7 lbs)	●	●
HM1205C	1,510	19.1	25.5	9.7 kg (21.5 lbs)		
HM1203C	1,510	19.1	25.5	9.7 kg (21.5 lbs)		
HM1214C	1,510	19.9	26.0	12.3 kg (27.1 lbs)	●	●

30mm Hex Shank

HM1306	1,510	21.7	28.8	15.1 kg (33.3 lbs)		
HM1317C	1,510	25 (100-127V:21)	33.8	17.0 kg (37.5 lbs)	●	●
HM1307C	1,510	25.5	33.8	15.3 kg (33.8 lbs)		
HM1400	1,240	29.5	33.7	18.1 kg (39.9 lbs)		

28.6mm Hex Shank

HM1317CB	1,510	26.5 (100-127V:24)	33.8	19.0 kg (41.9 lbs)	●	●
HM1307CB	1,510	23.6	33.8	17.3 kg (38.2 lbs)		
HM1802	2,000	71.4	62	29.4 kg (64.8 lbs)		
HM1812	2,000	72.8	62	31.3 kg (69 lbs)	●	●



Cutting



Dustless Cutter

303 MW

4100KB
125 mm (5")



Continuous rating input	1,400W
Blade Diameter	125 mm (5")
Max Cutting Capacity	40.0 mm (1-9/16")
No Load Speed (RPM)	12,200
Vibration Level	Concrete Cutting: 6.0 m/s ²
Sound Pressure Level	96 dB(A)
Sound Power Level	107 dB(A)
Dimensions (L x W x H)	231x220x179 mm (9-1/8"x8-5/8"x7")
Net weight	3.0 kg (6.6 lbs.)
Power supply cord	2.5 m (8.2 ft.)

4100KB



Cutter

303 MW

4100NH3
110 mm (4-3/8")



Continuous rating input	1,300W
Blade Diameter	110 mm (4-3/8")
Max Cutting Capacity	90°: 32 mm (1-1/4")
No Load Speed (RPM)	13,800
Dimensions (L x W x H)	227x209x166 mm (8-15/16"x8-1/4"x6-1/2")
Net weight	2.8 kg (6.2 lbs.)
Power supply cord	2.0 m (6.6 ft.)

4100NH3Z



Angle Cutter

204 MW

4112HS
305 mm (12")



Continuous rating input	2,400W
Capacity	Max cutting : 100 mm (4")
Blade Diameter	305 mm (12")
No Load Speed (RPM)	5,000
Overall Length	648 mm (25-1/2")
Net weight	10.4 kg (22.9 lbs.)
Power supply cord	2.5 m (8.2 ft.)

4112HS



Angle Cutter

204 MW

4114S
355 mm (14")



Continuous rating input	2,400W
Capacity	Max cutting : 125 mm (5")
Wheel Diameter	355 mm (14")
Hole Diameter	25.4 mm (1")
No Load Speed (RPM)	3,500
Dimensions (L x W x H)	673x240x329 mm (26-1/2"x9-1/2"x13")
Net weight	10.8 kg (23.9 lbs.)
Power supply cord	2.5 m (8.2 ft.)

4114S



Wall Chaser

318 MW

SG1251J
125 mm (5")



Continuous rating input	1,400W
Capacity	Depth: 0-30 mm (0 - 1-3/16")
	Width: 6-30 mm (1/4 - 1-3/16")
Blade Diameter	125 mm (5")
No Load Speed (RPM)	10,000
Dimensions (L x W x H)	350x151x178 mm (13-3/4"x5-15/16"x7")
Net weight	4.3 kg (9.5 lbs.)
Power supply cord	5.0 m (16.4 ft.)

SG1251J



Metal Cutting Saw

203 MW

LC1230
305 mm (12")



Continuous rating input	1,750W
Blade Diameter	305 mm (12")
Max Cutting Capacity	90°: 115 mm (4-1/2")
	90°: 75 x 150 mm (2-15/16" x 5-7/8")
	45°: 90 mm (3-1/2")
	45°: 85 x 85 mm (3-5/16" x 3-5/16")
No Load Speed (RPM)	1,300
Dimensions (L x W x H)	516x306x603 mm (20-1/4"x12"x23-3/4")
Net weight	19.3 kg (42.5 lbs.)
Power supply cord	2.5 m (8.2 ft.)

LC1230



Metal Cutter

Continuous rating input	1,100W
Blade Diameter	185 mm (7-1/4")
Capacity	Max cutting : 63 mm (2-1/2")
No Load Speed (RPM)	3,500
Overall Length	358 mm (14-1/8")
Net weight	4.8 kg (11.3 lbs.)
Power supply cord	2.5 m (8.2 ft.)

4131

4131
185 mm (7-1/4")



Portable Cut-off

203 MW

LW1400
355 mm (14")



Continuous rating input	2,200W
Wheel Diameter	355 mm (14")
No Load Speed (RPM)	3,800
Capacity at 90°	Round: 127 mm (5")
	Rectangular: 115x130 mm (4-1/2"x5-1/8")
Capacity at 45°	Round: 127 mm (5")
	Rectangular: 115x103 mm (4-1/2"x4-1/16")
Vibration Level	2.5 m/s ² or less
Sound Pressure Level	102 dB(A)
Sound Power Level	110 dB(A)
Dimensions (L x W x H)	530x295x640 mm (20-7/8"x11-5/8"x25-1/4")
Net weight	18.7 kg (41.2 lbs.)
Power supply cord	2.5 m (8.2 ft.)

LW1400

Toolless



Portable Cut-off

203 MW

LW1401
355 mm (14")



Continuous rating input	2,200W
Wheel Diameter	355 mm (14")
No Load Speed (RPM)	3,800
Capacity at 90°	Round: 127 mm (5")
	Rectangular: 115x130 mm (4-1/2"x5-1/8")
Capacity at 45°	Round: 127 mm (5")
	Rectangular: 115x103 mm (4-1/2"x4-1/16")
Vibration Level	2.5 m/s ² or less
Sound Pressure Level	102 dB(A)
Sound Power Level	110 dB(A)
Dimensions (L x W x H)	500x295x640 mm (19-3/4"x11-5/8"x25-1/4")
Net weight	18.3 kg (40.3 lbs.)
Power supply cord	2.5 m (8.2 ft.)

LW1401

Metal Shear

459

JS1602
1.6 mm (16 Ga)



Continuous rating input	380W
Capacity	Steel up to 400 N/mm ² : 1.6 mm
	Steel up to 600 N/mm ² : 1.2 mm
	Steel up to 800 N/mm ² : 0.8 mm
	Aluminum up to 200 N/mm ² : 2.5 mm
Min. cutting radius	30 mm (1-3/16")
Strokes Per Minute (SPM)	4,000
Dimensions (L x W x H)	255x74x146 mm (10"x2-15/16"x5-3/4")
Net weight	1.6 kg (3.4 lbs.)
Power supply cord	2.5 m (8.2 ft)

JS1602

Portable Band Saw

303

2107FK



Continuous rating input	710W
Capacity	Round: 120 mm (4-3/4") Rectangular workpiece w/o stand: 120x120 mm (4-3/4"x4-3/4")
Blade speed	60 m (200 ft) - 105 m (350 ft) / min
Dimensions (L x W x H)	508x188x256 mm (20"x7-3/8"x10-1/8")
Net weight	6.3 kg (13.9 lbs.)
Power supply cord	2.5 m (8.2 ft)

2107FK



Straight Metal Shear

459

JS1601
1.6 mm (16 Ga)



Continuous rating input	380W
Capacity	Steel up to 400 N/mm ² : 1.6 mm
	Steel up to 600 N/mm ² : 1.2 mm
	Steel up to 800 N/mm ² : 0.8 mm
	Aluminum up to 200 N/mm ² : 2.5 mm
Min. cutting radius	250 mm (9-7/8")
Strokes Per Minute (SPM)	4,500
Dimensions (L x W x H)	320x70x78 mm (12-5/8"x2-3/4"x3-1/16")
Net weight	1.4 kg (3.2 lbs.)
Power supply cord	2.5 m (8.2 ft)

JS1601

Metal Shear

303

JS3201
3.2 mm (10 Ga)



Continuous rating input	710W
Capacity	Steel up to 400 N/mm ² : 3.2 mm
	Steel up to 600 N/mm ² : 2.5 mm
	Steel up to 800 N/mm ² : 1.5 mm
	Aluminum up to 200 N/mm ² : 4.0 mm
Min. cutting radius	50 mm (2")
Strokes Per Minute (SPM)	1,600
Dimensions (L x W x H)	213x90x239 mm (8-3/8"x3-1/2"x9-3/8")
Net weight	3.4 kg (7.5 lbs.)
Power supply cord	2.5 m (8.2 ft)

JS3201

Nibbler

411

JN1601
1.6 mm (16 Ga)



Continuous rating input	550W
Capacity	Steel up to 400 N/mm ² : 1.6 mm
	Steel up to 600 N/mm ² : 1.2 mm
	Steel up to 800 N/mm ² : 0.8 mm
	Aluminum up to 200 N/mm ² : 2.5 mm
Min. cutting radius	Outside edge: 50 mm (2") Inside edge: 45 mm (1-3/4")
Strokes Per Minute (SPM)	2,200
Overall Length	261 mm (10-1/4")
Net weight	1.6 kg (3.6 lbs.)
Power supply cord	2.0 m (6.6 ft)

JN1601

Nibbler

303

JN3201
3.2 mm (10 Ga)



Continuous rating input	710W
Capacity	Steel up to 400 N/mm ² : 3.2 mm
	Steel up to 600 N/mm ² : 2.5 mm
	Steel up to 800 N/mm ² : 1.0 mm
	Aluminum up to 200 N/mm ² : 3.5 mm
Min. cutting radius	Outside edge: 128 mm (5-1/16") Inside edge: 120 mm (4-3/4")
Strokes Per Minute (SPM)	1,300
Dimensions (L x W x H)	225x90x254 mm (8-7/8"x1-1/2"x10")
Net weight	3.4 kg (7.4 lbs.)
Power supply cord	2.5 m (8.2 ft)

JN3201

Aluminum Groove Cutter

303

CA5000X
118 mm (4-5/8")



Continuous rating input	1,300W
Blade	Type: Cutter blade / TCT saw blade
Max cutting capacity w/ Guide rail:	11 mm (7/16")
Cutter blade	w/ Guide rail: 36 mm (1-7/16")
Max cutting capacity w/ w/o Guide rail:	TCT Saw blade 41 mm (1-5/8")
No Load Speed (RPM)	2,200-6,400
Dimensions (L x W x H)	346x250x250 mm (13-5/8"x9-7/8"x9-7/8")
Net weight	4.7 kg (10.4 lbs.)
Power supply cord	2.5 m (8.2 ft)

CA5000X



PRODUCTS

▣ GRINDING / SANDING





SJS II

SUPER JOINT SYSTEM

To suppress vibration to operator

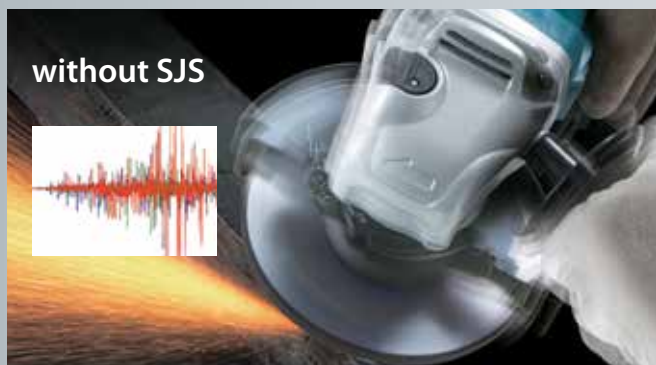

Structure of Super Joint System II

Leaf spring absorbs vibration and relieves shock during operation.



Absorption mechanism of vibration

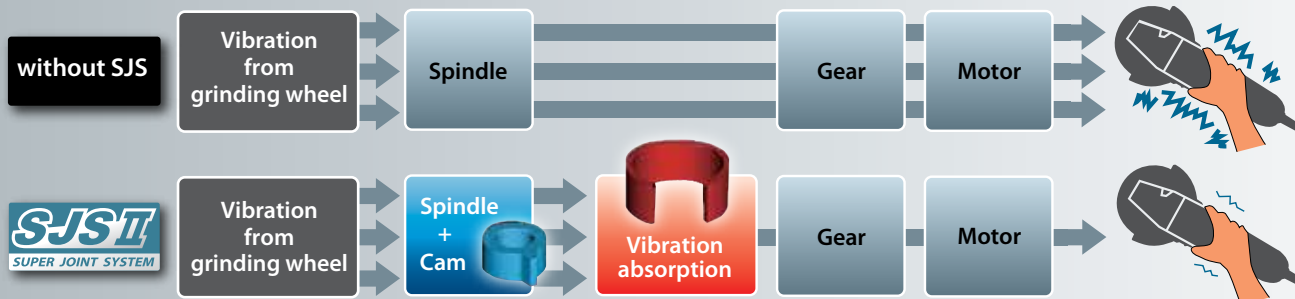

100mm
Angle Grinder
GA4041C, GA4040C,
GA4040



115mm
Angle Grinder
GA4541C, GA4543C,
GA4540C, GA4542C,
GA4541R, GA4541,
GA4540R, GA4540



125mm
Angle Grinder
GA5041C, GA5043C,
GA5040C, GA5042C,
GA5041R, GA5041,
GA5040R, GA5040



150mm
Angle Grinder
GA6040C, GA6042C,
GA6040R, GA6040



180mm
Angle Grinder
GA7063, GA7063R,
GA7061, GA7061R



230mm
Angle Grinder
GA9063, GA9063R,
GA9061, GA9061R



115mm, 125mm
Angle Sander
SA4540C, SA4542C,
SA5040C

Angle Grinder

840 W Angle Grinder, Toggle Switch



325	9553NB
Continuous rating input	710W
Wheel Diameter	100 mm (4")
No Load Speed (RPM)	11,000
Dimensions (L x W x H)	258x118x97 mm (10-1/8"x4-5/8"x3-13/16")
Net weight	1.8 kg (3.9 lbs.)
Power supply cord	2.5 m (8.2 ft.)

9553NB



Depressed Center Wheel, Lock Nut Wrench, Side Grip

Angle Grinder

710 W Angle Grinder, Toggle Switch



325	9553B
Continuous rating input	710W
Wheel Diameter	100 mm (4")
No Load Speed (RPM)	11,000
Dimensions (L x W x H)	258x118x97 mm (10-1/8"x4-5/8"x3-13/16")
Net weight	1.5 - 1.9 kg (3.3 - 4.1 lbs.)
Power supply cord	2.5 m (8.2 ft.)

9553B



Depressed Center Wheel, Wheel Cover, Lock Nut Wrench

Angle Grinder

720 W Angle Grinder, Toggle Switch



459	GA4032
Continuous rating input	720W
Wheel Diameter	100 mm (4")
No Load Speed (RPM)	9,000
Dimensions (L x W x H)	259x118x104 mm (10-1/4"x4-5/8"x4-1/8")
Net weight	1.67 - 1.96 kg (3.68 - 4.32 lbs.)
Power supply cord	2.5 m (8.2 ft.)

GA4032



Depressed Center Wheel, Wheel Cover, Lock Nut Wrench

Angle Grinder

840 W Angle Grinder, Toggle Switch



325	9556HB
Continuous rating input	840W
Wheel Diameter	100 mm (4")
No Load Speed (RPM)	11,000
Dimensions (L x W x H)	271x118x97 mm (10-5/8"x4-5/8"x3-13/16")
Net weight	1.6 - 2.0 kg (3.6 - 4.4 lbs.)
Power supply cord	2.5 m (8.2 ft.)

9556HB



Depressed Center Wheel, Side Grip, Wheel Cover, Lock Nut Wrench

Angle Grinder

1,400 W SJS II Angle Grinder, Anti-Restart Function, Soft Start, Slide Switch



318	GA4040
Continuous rating input	1,400W
Wheel Diameter	100 mm (4")
No Load Speed (RPM)	2,800-11,000
Vibration Level	Surface Grinding w/ Anti-Vibration Side Grip: 5.0 m/s ² Disc Sanding w/ Anti-Vibration Side Grip: 2.5 m/s ² or less
Sound Pressure Level	86 dB(A)
Sound Power Level	97 dB(A)
Dimensions (L x W x H)	303x117x111 mm (11-7/8"x4-5/8"x4-3/8")
Net weight	2.3 - 2.6 kg (5.1 - 5.7 lbs.)
Power supply cord	2.5 m (8.2 ft.)

GA4040

Depressed Center Wheel, Side Grip, Wheel Cover, Lock Nut Wrench

Angle Grinder

1,450 W SJS Angle Grinder, Anti-Restart Function, Soft Start, Finger Trigger Switch



253	GA5020C
Continuous rating input	1,450W
Wheel Diameter	125 mm (5")
No Load Speed (RPM)	10,000
Vibration Level	Surface Grinding: 9.5 m/s ² Disc Sanding: 2.5 m/s ² or less
Sound Pressure Level	90 dB(A)
Sound Power Level	101 dB(A)
Dimensions (L x W x H)	390x139x120 mm (15-3/8"x5-1/2"x4-3/4")
Net weight	2.9 - 4.1 kg (6.5 - 9.1 lbs.)
Power supply cord	2.5 m (8.2 ft.)

GA5020C

Depressed Center Wheel, Side Grip, Wheel Cover, Lock Nut Wrench

Angle Grinder

1,400 W SJS Angle Grinder, Anti-Restart Function, Soft Start, Slide Switch



318 mm	9565CR	
Continuous rating input	1,400W	
Wheel Diameter	125 mm (5")	
No Load Speed (RPM)	12,000	
Vibration Level	Surface Grinding w/ Anti-Vibration Side Grip: 7.5 m/s ² Disc Sanding: 2.5 m/s ² or less	
Sound Pressure Level	82 dB(A)	
Sound Power Level	93 dB(A)	
Dimensions (L x W x H)	299x139x103 mm (11-3/4"x5-1/2"x4-1/16")	
Net weight	2.4 - 3.5 kg (5.2 - 7.7 lbs.)	
Power supply cord	2.5 m (8.2 ft)	

9565CR

Depressed Center Wheel, Side Grip, Wheel Cover, Lock Nut Wrench

Angle Grinder

100 mm (4") 1,300 W Angle Grinder, Anti-Restart Function, Paddle Switch



GA452R/ GA5052R

260 mm	GA4050R	GA5050R
Continuous rating input	1,300W	1,300W
Wheel Diameter	100 mm (4")	125 mm (5")
No Load Speed (RPM)	11,000	11,000
Vibration Level	Surface Grinding w/ Anti-Vibration Side Grip: 5.5 m/s ² Disc Sanding w/ Anti-Vibration Side Grip: 2.5 m/s ² or less	Surface Grinding w/ Anti-Vibration Side Grip: 8.5 m/s ² Disc Sanding w/ Anti-Vibration Side Grip: 2.5 m/s ² or less
Sound Pressure Level	91 dB(A)	91 dB(A)
Sound Power Level	102 dB(A)	102 dB(A)
Dimensions (L x W x H)	325 x 117 x 100 mm (12-3/4 x 4-5/8 x 4-5/16")	325 x 140 x 117 mm (12-3/4 x 5-1/2 x 4-5/8")
Net weight	2.3 - 2.6 kg (5.1 - 5.7 lbs.)	2.5 - 2.8 kg (5.5 - 6.2 lbs.)
Power supply cord	2.5 m (8.2 ft)	2.5 m (8.2 ft)

Depressed Center Wheel, Side Grip, Wheel Cover, Lock Nut Wrench

GA4050R

GA5050R

Angle Grinder

1,100 W SJS II Angle Grinder, Anti-Restart Function, Soft Start, Slide Switch



325 mm	GA5040R	
Continuous rating input	1,100W	
Wheel Diameter	125 mm (5")	
No Load Speed (RPM)	11,000	
Vibration Level	Surface Grinding w/ Anti-Vibration Side Grip: 6.0 m/s ² Disc Sanding: 2.5 m/s ² or less	
Sound Pressure Level	86 dB(A)	
Sound Power Level	97 dB(A)	
Dimensions (L x W x H)	303x140x116 mm (11-7/8"x5-1/2"x4-9/16")	
Net weight	2.5 - 3.6 kg (5.4 - 8.0 lbs.)	
Power supply cord	2.5 m (8.2 ft)	

GA5040R

Depressed Center Wheel, Side Grip, Wheel Cover, Lock Nut Wrench

Angle Grinder

1,050 W SJS Angle Grinder, Finger Trigger Switch



303 mm	GA5010	
Continuous rating input	1,050W	
Wheel Diameter	125 mm (5")	
No Load Speed (RPM)	12,000	
Vibration Level	9.5 m/s ² Disc Sanding: 2.5 m/s ² or less	
Sound Pressure Level	89 dB(A)	
Sound Power Level	100 dB(A)	
Dimensions (L x W x H)	356x139x112 mm (14"x5-1/2"x4-3/8")	
Net weight	2.6 - 3.8 kg (5.8 - 8.4 lbs.)	
Power supply cord	2.5 m (8.2 ft)	

GA5010

Depressed Center Wheel, Side Grip, Wheel Cover, Lock Nut Wrench

Angle Grinder

125 mm (5") 840 W Angle Grinder, Slide Switch



325 mm	9558HN	
Continuous rating input	840W	
Wheel Diameter	125 mm (5")	
No Load Speed (RPM)	11,000	
Vibration Level	Surface Grinding: 8.5 m/s ² Disc Sanding: 2.5 m/s ² or less	
Sound Pressure Level	86 dB(A)	
Sound Power Level	97 dB(A)	
Dimensions (L x W x H)	271x139x106 mm (10-5/8"x5-1/2"x4-3/16")	
Net weight	1.7 - 3.0 kg (3.8 - 6.6 lbs.)	
Power supply cord	2.5 m (8.2 ft)	

9558HN

Depressed Center Wheel, Side Grip, Wheel Cover, Lock Nut Wrench

Angle Grinder

2,600 W Angle Grinder, Soft Start, Large Trigger Switch



204	GA9040S
Continuous rating input	2,600W
Wheel Diameter	230 mm (9")
No Load Speed (RPM)	6,600
Vibration Level	Surface Grinding: 5.5 m/s ² Disc Sanding: 2.5 m/s ² or less
Sound Pressure Level	90 dB(A)
Sound Power Level	101 dB(A)
Dimensions (L x W x H)	503x250x140 mm (19-3/4"x9-7/8"x5-1/2")
Net weight	6.65 - 8.94 kg (14.7 - 19.7 lbs.)
Power supply cord	2.5 m (8.2 ft)

GA9040S



Side Grip, Wheel Cover, Lock Nut Wrench

Angle Grinder

2,400 W Angle Grinder, Large Trigger Switch



204	GA7030	GA9030
Continuous rating input	2,400W	2,400W
Wheel Diameter	180 mm (7")	230 mm (9")
No Load Speed (RPM)	8,500	6,600
Vibration Level	Surface Grinding: 6.5 m/s ² Disc Sanding: 2.5 m/s ²	Surface Grinding: 6.5 m/s ² Disc Sanding: 2.5 m/s ² or less
Sound Pressure Level	89 dB(A)	90 dB(A)
Sound Power Level	100 dB(A)	101 dB(A)
Dimensions (L x W x H)	511x200x140 mm (20-1/8"x7-7/8"x5-1/2")	503x250x140 mm (19-3/4"x9-7/8"x5-1/2")
Net weight	6.06 - 6.56 kg (13.36 - 14.46 lbs.)	6.26 - 8.55 kg (13.8 - 18.9 lbs.)
Power supply cord	2.5 m (8.2 ft)	2.5 m (8.2 ft)

GA7030
GA9030

Side Grip, Wheel Cover, Lock Nut Wrench

Angle Grinder

2,200 W SJS II Angle Grinder, Anti-Restart Function, Soft Start, Large Trigger Switch



218	GA7061R	GA9061R
Continuous rating input	2,200W	2,200W
Wheel Diameter	180 mm (7")	230 mm (9")
No Load Speed (RPM)	8,500	6,600
Vibration Level	Surface Grinding w/ Anti-Vibration Side Grip: 6.5 m/s ² Disc Sanding w/ Anti-Vibration Side Grip: 2.5 m/s ²	Surface Grinding w/ Anti-Vibration Side Grip: 5.5 m/s ² Disc Sanding w/ Anti-Vibration Side Grip: 2.5 m/s ² or less
Sound Pressure Level	91 dB(A)	91 dB(A)
Sound Power Level	102 dB(A)	102 dB(A)
Dimensions (L x W x H)	450x200x145 mm (17-3/4"x7-7/8"x5-3/4")	450x250x145 mm (17-3/4"x9-7/8"x5-3/4")
Net weight	5.57 - 6.08 kg (12.3 - 13.4 lbs.)	5.68 - 8.04 kg (12.5 - 17.7 lbs.)
Power supply cord	2.5 m (8.2 ft)	2.5 m (8.2 ft)

GA7061R
GA9061R

Side Grip, Wheel Cover, Lock Nut Wrench

Angle Grinder

2,200 W SJS II Angle Grinder, Large Trigger Switch



218	GA7061	GA9061
Continuous rating input	2,200W	2,200W
Wheel Diameter	180 mm (7")	230 mm (9")
No Load Speed (RPM)	8,500	6,600
Vibration Level	Surface Grinding w/ Anti-Vibration Side Grip: 6.5 m/s ² Disc Sanding w/ Anti-Vibration Side Grip: 2.5 m/s ²	Surface Grinding w/ Anti-Vibration Side Grip: 5.5 m/s ² Disc Sanding w/ Anti-Vibration Side Grip: 2.5 m/s ² or less
Sound Pressure Level	91 dB(A)	91 dB(A)
Sound Power Level	102 dB(A)	102 dB(A)
Dimensions (L x W x H)	450x200x145 mm (17-3/4"x7-7/8"x5-3/4")	450x250x145 mm (17-3/4"x9-7/8"x5-3/4")
Net weight	5.53 - 6.04 kg (12.2 - 13.3 lbs.)	5.63 - 7.99 kg (12.4 - 17.6 lbs.)
Power supply cord	2.5 m (8.2 ft)	2.5 m (8.2 ft)

GA7061
GA9061

Side Grip, Wheel Cover, Lock Nut Wrench

Angle Grinder

2,200 W Angle Grinder, Anti-Restart Function, Soft Start, Large Trigger Switch



218	GA7060R	GA9060R
Continuous rating input	2,200W	2,200W
Wheel Diameter	180 mm (7")	230 mm (9")
No Load Speed (RPM)	8,500	6,600
Vibration Level	Surface Grinding w/ Anti-Vibration Side Grip: 7.5 m/s ² Disc Sanding w/ Anti-Vibration Side Grip: 2.5 m/s ²	Surface Grinding w/ Anti-Vibration Side Grip: 6.0 m/s ² Disc Sanding w/ Anti-Vibration Side Grip: 2.5 m/s ² or less
Sound Pressure Level	91 dB(A)	91 dB(A)
Sound Power Level	102 dB(A)	102 dB(A)
Dimensions (L x W x H)	450x200x144 mm (17-3/4"x7-7/8"x5-5/8")	450x250x144 mm (17-3/4"x9-7/8"x5-5/8")
Net weight	5.42 - 5.93 kg (12 - 13.1 lbs.)	5.52 - 7.88 kg (12.8 - 17.4 lbs.)
Power supply cord	2.5 m (8.2 ft)	2.5 m (8.2 ft)

GA7060R
GA9060R

Side Grip, Wheel Cover, Lock Nut Wrench

Angle Grinder

2,200 W Angle Grinder, Large Trigger Switch



218	GA7060	GA9060
Continuous rating input	2,200W	2,200W
Wheel Diameter	180 mm (7")	230 mm (9")
No Load Speed (RPM)	8,500	6,600
Vibration Level	Surface Grinding w/ Anti-Vibration Side Grip: 7.5 m/s ² Disc Sanding w/ Anti-Vibration Side Grip: 2.5 m/s ²	Surface Grinding w/ Anti-Vibration Side Grip: 6.0 m/s ² Disc Sanding w/ Anti-Vibration Side Grip: 2.5 m/s ² or less
Sound Pressure Level	91 dB(A)	91 dB(A)
Sound Power Level	102 dB(A)	102 dB(A)
Dimensions (L x W x H)	450x200x144 mm (17-3/4"x7-7/8"x5-5/8")	450x250x144 mm (17-3/4"x9-7/8"x5-5/8")
Net weight	5.38 - 5.89 kg (11.9 - 13 lbs.)	5.50 - 7.86 kg (12.1 - 17.3 lbs.)
Power supply cord	2.5 m (8.2 ft)	2.5 m (8.2 ft)

Side Grip, Wheel Cover, Lock Nut Wrench

GA7060
GA9060

Angle Grinder

2,200 W Angle Grinder, Large Trigger Switch



204	GA7020	GA9020
Continuous rating input	2,200W	2,200W
Wheel Diameter	180 mm (7")	230 mm (9")
No Load Speed (RPM)	8,500	6,000
Vibration Level	Surface Grinding w/ Anti-Vibration Side Grip: 8.0 m/s ² Disc Sanding: 2.5 m/s ²	Surface Grinding: 5.5 m/s ² Disc Sanding: 2.5 m/s ² or less
Sound Pressure Level	89 dB(A)	89 dB(A)
Sound Power Level	100 dB(A)	100 dB(A)
Dimensions (L x W x H)	473x200x140 mm (18-5/8"x7-7/8"x5-1/2")	473x249x140 mm (18-5/8"x9-3/4"x5-1/2")
Net weight	5.56 - 6.06 kg (12.26 - 13.36 lbs.)	5.76 - 8.05 kg (12.7 - 17.8 lbs.)
Power supply cord	2.5 m (8.2 ft)	2.5 m (8.2 ft)

Side Grip, Wheel Cover, Lock Nut Wrench

GA7020
GA9020

Angle Grinder

2,000 W Angle Grinder, Anti-Restart Function, Soft Start, Large Trigger Switch



204	GA7050R
Continuous rating input	2,000W
Wheel Diameter	180 mm (7")
No Load Speed (RPM)	8,500
Vibration Level	Surface Grinding: 6.5 m/s ² Disc Sanding: 4.0 m/s ²
Sound Pressure Level	94 dB(A)
Sound Power Level	105 dB(A)
Dimensions (L x W x H)	455x200x132 mm (17-7/8"x7-7/8"x5-3/16")
Net weight	4.66 - 5.18 kg (10.3 - 11.4 lbs.)
Power supply cord	2.5 m (8.2 ft)

Side Grip, Wheel Cover, Lock Nut Wrench

GA7050R01

Angle Grinder

2,000 W Angle Grinder, Large Trigger Switch



204	GA7050
Continuous rating input	2,000W
Wheel Diameter	180 mm (7")
No Load Speed (RPM)	8,500
Vibration Level	Surface Grinding: 6.5 m/s ² Disc Sanding: 4.0 m/s ²
Sound Pressure Level	94 dB(A)
Sound Power Level	105 dB(A)
Dimensions (L x W x H)	432x200x132 mm (17"x7-7/8"x5-3/16")
Net weight	3.98 - 5.00 kg (8.8 - 11.0 lbs.)
Power supply cord	2.5 m (8.2 ft)

Side Grip, Wheel Cover, Lock Nut Wrench

GA7050



Product Comparison List

Angle Grinder

Model No.				Continuous rating Input	Switch	Anti-restart function	SJS	SJS2	Variable Speed	Brake	Constant Speed	Soft Start
100mm	115mm	125mm	150mm									
		GA5021C	GA6021C	1,450W	Large trigger	•	•				•	•
		GA5020C	GA6020C	1,450W	Finger trigger	•	•				•	•
GA4041C	GA4541C	GA5041C		1,400W	Slide	•		•	•	•	•	•
GA4040C	GA4540C	GA5040C	GA6040C	1,400W	Slide	•		•	•		•	•
	GA4542C	GA5042C	GA6042C	1,400W	Slide			•	•		•	•
	GA4543C	GA5043C		1,400W	Slide			•	•	•	•	•
	9564CVR	9565CVR	9566CVR	1,400W	Slide	•	•		•		•	•
	9564CV	9565CV	9566CV	1,400W	Slide		•		•		•	•
	9564CR	9565CR	9566CR	1400W	Slide	•	•				•	•
	9564C	9565C	9566C	1,400W	Slide		•				•	•
	9564PCV	9565PCV	9566PCV	1,400W	Paddle		•		•		•	•
	9564PC	9565PC	9566PC	1,400W	Paddle		•				•	•
		9565CVL / 9565CLR		1,400W	Slide	-/•	•		•		•	•
	9561CR / 9561CVR			1,200W	Slide	•	•		-/•		•	•
	GA4541R	GA5041R		1,100W	Slide	•		•		•		
	GA4541	GA5041		1,100W	Slide			•		•		
	GA4540R	GA5040R	GA6040R	1,100W	Slide	•		•				•
	GA4540R	GA5040R	GA6040R	1,100W	Slide	•		•				•
	9564HR	9565HR		1,100W	Slide	•	•					•
9563H	9564H	9565H		1,100W	Slide		•					
	9564P	9565P		1,100W	Paddle		•					
		GA5011 / GA5021	GA6021	1,050W	Large trigger		•					
		GA5010 / GA5020	GA6010 / GA6020	1,050W	Finger trigger		-/•					
9556NB / 9556HN	9557HN	9558HN		840W	Slide							
	9557NBR / 9557HNR	9558NBR / 9558HNR		840W	Slide	•						•
9556PB / 9556HP	9557PB / 9557HP	9558PB / 9558HP		840W	Paddle							
9556HB				840W	Toggle							
GA4031 / GA4032				720W	Toggle							
GA4030R	GA4530R	GA5030R		720W	Slide	•						•
GA4030t	GA4530	GA5030t		720W	Slide							
GA4034	GA4534	GA5034		720W	Paddle							
9553HN	9554HN	9555HN		710W	Slide							
9553B / 9553HB		9555B		710W	Toggle							
9500NB / N9500N				570W	Toggle							

Model No.			Continuous rating Input	Switch	Anti-restart function	Constant Speed	SJS2	Torque Limiter	Soft Start
180mm	230mm								
GA7040R	GA9040R		2,600W	Large trigger	•			•	•
GA7040S	GA9040		2,600W	Large trigger				•	•/-
GA7030R	GA9030R		2,400W	Large trigger	•			•	•
GA7030S / GA7030	GA9030S / GA9030		2,400W	Large trigger				•	•/-
GA7031	GA9031		2,400W	AC / DC trigger				•	
GA7061R	GA9061R		2,200W	Large trigger	•		•		•
GA7061 / GA7063	GA9061 / GA9063		2,200W	Large trigger			•		
GA7061R	GA9061R		2,200W	Large trigger	•				•
GA7060 / GA7064	GA9060 / GA9062		2,200W	Large trigger					
GA7020R	GA9020R		2,200W	Large trigger	•				•
GA7020S	GA9020S		2,200W	Large trigger					•
GA7020 / GA7021	GA9020		2,200W	Large trigger					
GA7050			2,000W	Large trigger					
GA7012C	GA9012C		1,800W	Large trigger	•	•			•
GA7010C	GA9010C		1,800W	Large trigger		•			•

Grinding / Sanding



Angle Sander

204

SA7000C
180 mm (7")



Continuous rating input	1,600W
Abrasive Disc Size	180 mm (7")
Capacity	Pad: 180 mm (7")
No Load Speed (RPM)	0-4,000
Dimensions (L x W x H)	453x170x136 mm (17-7/8"x6-11/16"x5-3/8")
Net weight	3.5 - 3.6 kg (7.7 - 7.9 lbs.)
Power supply cord	2.5 m (8.2 ft)



SA7000C

Polisher

303

9237C
180 mm (7")



Continuous rating input	1,200W
Capacity	Wool Pad: 180 mm (7") Wool Bonnet: 180 mm (7")
No Load Speed (RPM)	0 - 3,200
Vibration Level	2.5 m/s ² or less
Sound Pressure Level	83 dB(A)
Sound Power Level	94 dB(A)
Dimensions (L x W x H)	431x198x187 mm (17"x7-3/4"x7-3/8")
Net weight	3.2 - 3.4 kg (7 - 7.5 lbs.)
Power supply cord	2.5 m (8.2 ft)



9237C

Random Orbit Polisher

PO6000C
150 mm (6")



Continuous rating input	900W
Pad Size	150 mm (6")
Orbits Per Minute (OPM)	0 - 6,800
Strokes Per Minute (SPM)	0 - 13,600
No Load Speed (RPM)	0 - 780
Orbit Diameter	5.5 mm (7/32")
Vibration Level	Polishing: 7.0 m/s ²
Sound Pressure Level	83 dB(A)
Sound Power Level	94 dB(A)
Dimensions (L x W x H)	451x148x126 mm (17-3/4"x5-7/8"x5")
Net weight	2.8 - 3.0 kg (6.2 - 6.5 lbs.)
Power supply cord	4.0 m (13.1 ft)



PO6000C

Random Orbit Polisher

318

PO5000C
125 mm (5")



Continuous rating input	900W
Pad Size	125 mm (5")
Orbits Per Minute (OPM)	0 - 6,800
Strokes Per Minute (SPM)	0 - 13,600
No Load Speed (RPM)	0 - 780
Orbit Diameter	5.5 mm (7/32")
Vibration Level	Polishing: 6.5 m/s ²
Sound Pressure Level	81 dB(A)
Sound Power Level	92 dB(A)
Dimensions (L x W x H)	451x123x134 mm (17-3/4"x4-7/8"x5-1/4")
Net weight	2.8 - 3.0 kg (6.2 - 6.5 lbs.)
Power supply cord	4.0 m (13.1 ft)



PO5000C

Stone Polisher

318

PW5001C
125 mm (5")



Continuous rating input	900W
Capacity	Pad: 100-125 mm (4-5")
No Load Speed (RPM)	2,000-4,000
Overall Length	359 mm (14-1/8")
Net weight	2.3 - 2.6 kg (5.1 - 5.7 lbs.)
Power supply cord	4.0 m (13.1 ft)



PW5001C

Concrete Planer

253

PC5000C
125 mm (5")



Continuous rating input	1,400W
Wheel Diameter	125 mm (5")
Hole Diameter	22.23 mm (7/8")
No Load Speed (RPM)	10,000
Dimensions (L x W x H)	437x235x195 mm (17-1/8"x9-1/4"x7-5/8")
Net weight	4 kg (8.9 lbs.)
Power supply cord	5.0 m (16.4 ft)



PC5000C

Concrete Planer

253

PC5001C
125 mm (5")

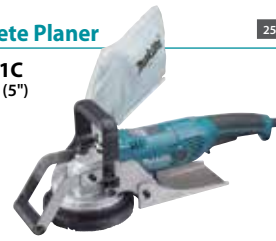

Continuous rating input	1,400W
Wheel Diameter	125 mm (5")
No Load Speed (RPM)	10,000
Dimensions (L x W x H)	479x182x195 mm (18-13/16"x7-1/8"x7-5/8")
Net weight	4 kg (8.9 lbs.)
Power supply cord	5 m (16.4 ft)



PC5001C

Concrete Planer

PC5010C
125 mm (5")



Continuous rating input	1,400W
Wheel Diameter	125 mm (5")
Hole Diameter	22.23 mm (7/8")
No Load Speed (RPM)	4,000 - 9,000
Vibration Level	Surface Grinding w / Loop Handle: 5.5 m/s ²
Sound Pressure Level	85.0 dB(A)
Sound Power Level	96.0 dB(A)
Dimensions (L x W x H)	350x231x179 mm (13-3/4"x9-1/8"x7")
Net weight	2.5 - 3.6 kg (5.5 - 7.9 lbs.)
Power supply cord	4.0 m (13.1 ft)



PC5010C

Die Grinder

64

GD0603
6 mm (1/4")



Continuous rating input	240W
Capacity	Collet: 6 mm or 1/4"
Max Wheel Diameter	19 mm (3/4")
No Load Speed (RPM)	28,000
Diameter of grip	65 mm
Circumference of grip	203 mm
Dimensions (L x W x H)	289x64x67 mm (11-3/8"x2-1/2"x2-5/8")
Net weight	0.98 kg (2.16 lbs.)
Power supply cord	2.5 m (8.2 ft)



GD0603

Die Grinder

325

GD0601
6 mm (1/4")



Continuous rating input	400W
Capacity	Collet: 3.6 mm or 1/8", 1/4"
Wheel Diameter	38 mm (1-1/2")
No Load Speed (RPM)	25,000
Dimensions (L x W x H)	359x82x82 mm (14-1/8"x3-1/4"x3-1/4")
Net weight	1.68 - 1.84 kg (3.70 - 4.06 lbs.)
Power supply cord	2.5 m (8.2 ft)



GD0601

Die Grinder

318

GD0801C
8 mm (1/4")



Continuous rating input	750W
Capacity	Collet: 8 mm (1/4")
Max Wheel Diameter	25 mm (1")
No Load Speed (RPM)	7,000-29,000
Vibration Level	Surface Grinding: 3.5 m/s ²
Sound Pressure Level	80 dB(A)
Sound Power Level	91 dB(A)
Dimensions (L x W x H)	390x75x88 mm (15-3/8"x2-15/16"x3-1/2")
Net weight	1.96 - 1.97 kg (4.32 - 4.34 lbs.)
Power supply cord	2.5 m (8.2 ft)



GD0801C

Tool does not come with wheel point.

Straight Grinder

204 

GS6000
150 mm (6")



Continuous rating input 750W
Wheel Diameter 150 mm (6")
Hole Diameter 12.7,20 mm (1/2,13/16")
No Load Speed (RPM) 5,600
Dimensions (L x W x H) 590x216x130 mm
(23-1/4"x8-1/2"x5-1/8")
Net weight 5.2-5.4 kg (11.4-12.0 lbs.)
Power supply cord 2.5 m (8.2 ft)

GS6000



Straight Grinder

204 

GS5000
125 mm (5")



Continuous rating input 750W
Wheel Diameter 125 mm (5")
Hole Diameter 12.7,20 mm (1/2,13/16")
No Load Speed (RPM) 5,600
Dimensions (L x W x H) 590x189x116 mm
(23-1/4"x7-7/16"x4-9/16")
Net weight 5.0-5.2 kg (11.0-11.5 lbs.)
Power supply cord 2.5 m (8.2 ft)

GS5000



Multi Tool

459 

TM3000CX1



Continuous rating input 320W
Strokes Per Minute (SPM) 6,000-20,000
Dimensions (L x W x H) 275x64x92 mm
(10-7/8"x2-1/2"x3-5/8")
Net weight 1.4-1.5 kg (3.2-3.3 lbs.)
Power supply cord 5.0 m (16.4 ft)

TM3000CX1



Bench Grinder

GB602
150 mm (6")



Continuous rating input 250W
Wheel Diameter 150 mm (6")
Wheel width 16 mm (5/8")
Hole Diameter 12.7 mm (1/2")
H.P. 1/3
No Load Speed (RPM) 2,850 (50 Hz) / 3,450 (60 Hz)
Sound Pressure Level 74 dB(A)
Dimensions (L x W x H) 375x205x286 mm
(14-9/16"x8"x11-17/64")
Net weight 9.31-9.08 kg
(20.02-20.52 lbs.)

GB602



Bench Grinder

GB801
205 mm (8")



Continuous rating input 550W
Wheel Diameter 205 mm (8")
Wheel width 19 mm (3/4")
Hole Diameter 15.88 mm (5/8")
H.P. 3/4
No Load Speed (RPM) 2,850 (50 Hz) / 3,450 (60 Hz)
Sound Pressure Level 77 dB(A)
Dimensions (L x W x H) 395x265x333 mm
(15-9/16"x10-7/16"x13-7/64")
Net weight 19.91-19.63 kg
(43.89-43.28 lbs.)

GB801



Belt Sander

411 

9032
9 mm x 533 mm (3/8" x 21")



Continuous rating input 500W
Belt Size 9 x 533 mm (3/8" x 21")
Belt Speed 300-1,700 m/min
(980-5,600 ft/min)
Max sanding depth 110 mm (4-5/16")
Overall Length 420 mm (16-1/2")
Net weight 1.6 kg (3.5 lbs.)
Power supply cord 2.5 m (8.2 ft)

9032



Belt Sander

411 

9031
30 mm x 533 mm (1-3/16" x 21")



Continuous rating input 550W
Belt Size 30 x 533 mm (1-1/8" x 21")
Belt Speed 200-1,000 m/min
(656-3,280 ft/min)
Overall Length 380 mm (15")
Net weight 2.1 kg (4.6 lbs.)
Power supply cord 2.5 m (8.2 ft)

9031



Wheel Sander

100 

9741



Continuous rating input 860W
Wheel Diameter 100 x 120 mm (4" x 4-3/4")
No Load Speed (RPM) 3,500
Overall Length 310 mm (12-1/4")
Net weight 4.2 kg (9.3 lbs.)
Power supply cord 5.0 m (16.4 ft)

9741



Finishing Sander

64 

BO3710



Continuous rating input 190W
Pad Size 93 x 185 mm (3-5/8" x 7-1/4")
Abrasive Paper Size 93 x 228 mm (3-5/8" x 9")
Orbits Per Minute (OPM) 11,000
Strokes Per Minute (SPM) 22,000
Orbit Diameter 2.0 mm (1/16")
Vibration Level Sanding Metal Plate: 3.5 m/s²
Sound Pressure Level 72 dB(A)
Dimensions (L x W x H) 253x92x154 mm
(10"x3-5/8"x6-1/16")
Net weight 1.6 kg (3.5 lbs.)
Power supply cord 2.0 m (6.6 ft)

BO3710



Finishing Sander

419 

BO4556



Continuous rating input 200W
Pad Size 112 x 102 mm (4-3/8" x 4")
Abrasive Paper Size 114 x 140 mm
(4-1/2" x 5-1/2")
Orbits Per Minute (OPM) 14,000
Dimensions (L x W x H) 131x112x141 mm
(5-1/8"x4-3/8"x5-9/16")
Net weight 1.1 kg (2.5 lbs.)
Power supply cord 2.0 m (6.6 ft)

BO4556



Random Orbit Sander

419 

BO5031



Continuous rating input 300W
Pad diameter 123 mm (4-7/8")
Abrasive Disc Size 125 mm (5")
Orbits Per Minute (OPM) 4,000-12,000
Dimensions (L x W x H) 153x123x153 mm
(6"x4-7/8"x6")
Net weight 1.3 kg (3 lbs.)
Power supply cord 2.0 m (6.6 ft)

BO5031



Random Orbit Sander

419 

BO6030



Continuous rating input 310W
Pad diameter 150 mm (6")
Abrasive Disc Size 150 mm (6")
Orbits Per Minute (OPM) 4,000-10,000
Overall Length 309 mm (12-1/8")
Orbit Diameter 3.0 mm (1/8")
Net weight 2.4 kg (5.2 lbs.)
Power supply cord 2.5 m (8.2 ft)

BO6030



Sawing



Slide Compound Miter Saw

LS1019L
260 mm (10-1/4")



DXT



153 WMI

Continuous rating input	1,510W
Blade Diameter	260 mm (10-1/4")
Bevel Angle	48° L / 48° R
Miter Angle	60° L / 60° R
Max Cutting Capacity (Bevel/Miter)	90°/90°: 68 x 310 mm 90°/45°LR: 68 x 218 mm
No Load Speed (RPM)	3,200
Sound Pressure Level	91 dB(A)
Sound Power Level	101 dB(A)
Vibration Level	2.5 m/s ² or less
Dimensions (L x W x H)	805x644x660 mm (31-3/4"x25-3/8"x26")
Net weight	26.3 kg (57.9 lbs.)
Power supply cord	2.5 m (8.2 ft.)

LS1019L

Slide Compound Miter Saw

LS1219L
305 mm (12")



DXT



153 WMI

Continuous rating input	1,800W
Blade Diameter	305 mm (12")
Bevel Angle	48° L / 48° R
Miter Angle	60° L / 60° R
Max Cutting Capacity (Bevel/Miter)	90°/90°: 92 x 382 mm (3-5/8" x 15") 90°/45°LR: 92 x 268 mm (3-5/8" x 10-1/2")
No Load Speed (RPM)	3,200
Sound Pressure Level	91 dB(A)
Sound Power Level	100 dB(A)
Vibration Level	2.5 m/s ² or less
Dimensions (L x W x H)	898x664x725 mm (35-1/4"x26-1/8"x28-1/2")
Net weight	29.5 kg (65.0 lbs.)
Power supply cord	2.5 m (8.2 ft.)

LS1219L

Compound Miter Saw

LS1221
305 mm (12")



153 WMI

Continuous rating input	1,650W
Blade Diameter	305 mm (12")
Miter Angle	48° L / 48° R
Bevel Angle	45° L
Max Cutting Capacity	90°: 98 x 153 mm (3-7/8" x 6") 45°: 70 x 149 mm (2-3/4" x 5-7/8")
No Load Speed (RPM)	4,000
Dimensions (L x W x H)	674x610x607 mm (26-1/2"x24"x23-7/8")
Net weight	16.8 kg (37.0 lbs.)
Power supply cord	2.5 m (8.2 ft.)

LS1221

Compound Miter Saw

LS1045
260 mm (10-1/4")



153 WMI

Continuous rating input	1,650W
Blade Diameter	260 mm (10-1/4")
Miter Angle	45° L / 52° R
Bevel Angle	45° L
Max Cutting Capacity	90°: 90.5 x 95 mm (3-9/16" x 3-3/4") 45°: 90.5 x 67 mm (3-9/16" x 2-5/8")
No Load Speed (RPM)	4,600
Dimensions (L x W x H)	530x476x532 mm (20-7/8"x18-3/4"x21")
Net weight	19.1 kg (42.0 lbs.)
Power supply cord	2.5 m (8.2 ft.)

LS1045

Table Top Miter Saw

LH1200FL
305 mm (12")



153 WMI

Continuous rating input	1,650W
Blade Diameter	305 mm (12")
Miter Angle	47° L / 52° R
Bevel Angle	45° L
Max Cutting Capacity	90°: 62 x 200 mm (2-7/16" x 7-7/8") 90°: 95 x 155 mm (3-3/4" x 6-1/8") 45° Miter, L/R: 62 x 135 mm (2-7/16" x 5-5/16") 45° Miter, L/R: 95 x 110 mm (3-3/4" x 4-5/16") 90° Table saw: 52 mm (2-1/16")
No Load Speed (RPM)	3,800
Dimensions (L x W x H)	610x535x692 mm (24"x21"x27-1/4")
Net weight	20.7 kg (45.6 lbs.)
Power supply cord	2.5 m (8.2 ft.)

LH1200FL - Rs. 75,000

Compound Miter Saw

LS1040
260 mm (10-1/4")



153 WMI

Continuous rating input	1,650W
Blade Diameter	260 mm (10-1/4")
Miter Angle	45° L / 52° R
Bevel Angle	45° L
Max Cutting Capacity	90°: 90.5 x 95 mm (3-9/16" x 3-3/4") 45°: 90.5 x 67 mm (3-9/16" x 2-5/8")
No Load Speed (RPM)	4,600
Sound Pressure Level	93 dB(A)
Sound Power Level	106 dB(A)
Dimensions (L x W x H)	530x476x532 mm (20-7/8"x18-3/4"x21")
Net weight	12.4 kg (27.3 lbs.)
Power supply cord	2.5 m (8.2 ft.)

Tool does not come with saw blade.

LS1040

Miter Saw

LS1030N
260 mm (10-1/4")



153 WMI

Continuous rating input	1,650W
Max Cutting Capacity	90°: 90.5 x 95 mm (3-9/16" x 3-3/4") 45°: 90.5 x 67 mm (3-9/16" x 2-5/8")
Blade Diameter	260 mm (10-1/4")
No Load Speed (RPM)	4,600
Dimensions (L x W x H)	530x476x532 mm (20-7/8"x18-3/4"x21")
Net weight	12.1 kg (26.7 lbs.)
Power supply cord	2.5 m (8.2 ft.)

Tool does not come with saw blade.

LS1030N

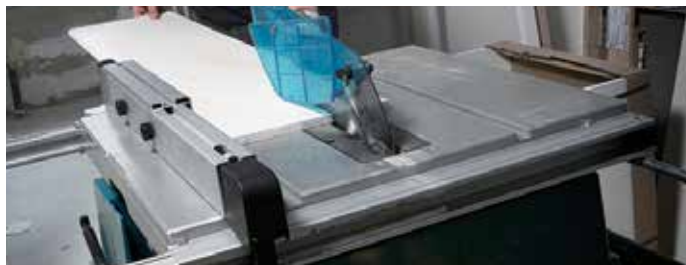

Table Saw

MLT100



JM23000123 WMI

Continuous rating input	1,500W
Max Cutting Capacity	90°: 93 mm (3-5/8") 45°: 64 mm (2-1/2")
Blade Diameter	260 mm (10-1/4")
No Load Speed (RPM)	4,300
Dimensions (L x W x H)	726x984x473 mm (28-1/2"x38-3/4"x18-5/8")
Net weight	34.9 kg (76.9 lbs.)
Power supply cord	2.5 m (8.2 ft.)

MLT100

Table Saw

2712
315 mm (12-3/8")



Max Cutting Capacity	90°: 85 mm (3-3/8") 45°: 58 mm (2-1/4")
Blade Diameter	315 mm (12-3/8")
No Load Speed (RPM)	50 Hz: 2,950 60 Hz: 3,400
Bevel Capacity	0° - 45°
Dimensions (L x W x H)	1,670x700x810 mm (65-3/4"x27-1/2"x32")
Net weight	54 kg (118.9 lbs.)
Power supply cord	3.0 m (9.8 ft.)

2712

Circular Saw

HS7010
185 mm (7-1/4") /
190 mm (7-1/2")



Continuous rating input	1,600W
Blade Diameter	185 / 190 mm (7-1/4" / 7-1/2")
Max Cutting Capacity	90°: 65 / 67 mm (2-9/16" / 2-5/8") 45°: 44 / 45 mm (1-3/4" / 1-3/4")
No Load Speed (RPM)	5,500
Dimensions (L x W x H)	300x240x261 mm (11-3/4"x9-1/2"x10-1/4")
Net weight	4.0 kg (8.9 lbs.)
Power supply cord	2.5 m (8.2 ft.)

HS7010

Circular Saw

HS7600
185 mm (7-1/4")

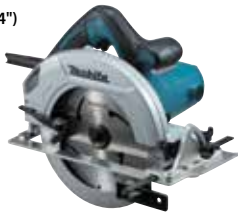

303

Continuous rating input	1,200W
Blade Diameter	185 mm (7-1/4")
Max Cutting Capacity	90°: 64 mm (2-1/2") 45°: 42 mm (1-5/8")
No Load Speed (RPM)	5,200
Vibration Level	Cutting Wood: 2.5 m/s ² or less
Sound Pressure Level	87 dB(A)
Sound Power Level	98 dB(A)
Dimensions (L x W x H)	309x234x255 mm (12-1/8"x9-1/4"x10")
Net weight	3.8 kg (8.3 lbs.)
Power supply cord	2.5 m (8.2 ft)

HS7600



Circular Saw

N5900B
235 mm (9-1/4")



153

Continuous rating input	2,000W
Max Cutting Capacity	90°: 85 mm (3-3/8") 45°: 60 mm (2-3/8") 50°: 53 mm (2-1/16")
Blade Diameter	235 mm (9-1/4")
No Load Speed (RPM)	4,100
Overall Length	380 mm (15")
Net weight	6.8 kg (14.8 lbs.)
Power supply cord	2.5 m (8.2 ft)

N5900B



Circular Saw

HS0600
260 mm (10-1/4") / 270 mm (10-5/8")



153

Continuous rating input	2,000W
Blade Diameter	260 / 270 mm
Max Cutting Capacity	(10-1/4" / 10-5/8") 90°: 97 / 101 mm (3-13/16" / 4") 45°: 68 / 71 mm (2-11/16" / 2-13/16")
No Load Speed (RPM)	4,300
Vibration Level	Cutting Wood: 2.5 m/s ² or less
Sound Pressure Level	94 dB(A)
Sound Power Level	105 dB(A)
Dimensions (L x W x H)	418x273x324 mm (16-1/2"x10-3/4"x12-3/4")
Net weight	6.9 kg (15.2 lbs.)
Power supply cord	2.5 m (8.2 ft)

HS0600



Circular Saw

5402NA
415 mm (16-5/16")



203

Continuous rating input	1,650W
Blade Diameter	415 mm (16-5/16")
Max Cutting Capacity	90°: 158 mm (6-1/4") 45°: 106 mm (4-3/16")
No Load Speed (RPM)	2,200
Overall Length	616 mm (24-1/4")
Net weight	12.5 kg (27.6 lbs.)
Power supply cord	5.0 m (16.4 ft)

5402NA



Plunge Cut Circular Saw

SP6000
165 mm (6-1/2")



303

Continuous rating input	1,300W
Blade Diameter	165 mm (6-1/2")
Max Cutting Capacity	90°: 56 mm (2-3/16") 45°: 40 mm (1-9/16") 48°: 38 mm (1-1/2")
No Load Speed (RPM)	2,200 - 6,400
Dimensions (L x W x H)	341x225x250 mm (13-3/8"x8-7/8"x9-7/8")
Net weight	4.1 kg (9 lbs.)
Power supply cord	2.5 m (8.2 ft)

SP6000



Jig Saw

4350CT



419

Continuous rating input	720W
Capacity	Wood: 135 mm (5-5/16") Steel: 10 mm (3/8")
Length of Stroke	26 mm (1")
Strokes Per Minute (SPM)	800 - 2,800
Dimensions (L x W x H)	236x73x207 mm (9-1/4"x2-7/8"x8-1/8")
Net weight	2.7 kg (5.8 lbs.)
Power supply cord	2.5 m (8.2 ft)

4350CT



Jig Saw

JV0600K



64

Continuous rating input	650W
Capacity	Wood: 90 mm (3-1/2") Steel: 10 mm (3/8")
Length of Stroke	23 mm (7/8")
Strokes Per Minute (SPM)	500 - 3,100
Dimensions (L x W x H)	236x77x199 mm (9-1/4"x3"x7-7/8")
Net weight	2.4 kg (5.3 lbs.)
Power supply cord	2.5 m (8.2 ft)

JV0600K



Jig Saw

4327



64

Continuous rating input	450W
Capacity	Wood: 65 mm (2-9/16") Steel: 6 mm (1/4")
Length of Stroke	18 mm (11/16")
Strokes Per Minute (SPM)	500 - 3,100
Dimensions (L x W x H)	224x77x197 mm (8-7/8"x3"x7-3/4")
Net weight	1.9 kg (4.2 lbs.)
Power supply cord	2.0 m (6.6 ft)

4327



Recipro Saw

JR3050T



303

Continuous rating input	1,010W
Length of Stroke	28 mm (1-1/8")
Strokes Per Minute (SPM)	0 - 2,800
Capacity	Pipe: 130 mm (3-1/2") Wood: 255 mm (10")
Vibration Level	Cutting Boards: 15.0 m/s ² Cutting Wooden Beams: 20.0 m/s ²
Sound Pressure Level	89 dB(A)
Sound Power Level	100 dB(A)
Overall Length	452 mm (17-3/4")
Net weight	3.3 kg (7.3 lbs.)
Power supply cord	2.5 m (8.2 ft)

JR3050T



Recipro Saw

JR3051T



303

Continuous rating input	1,200W
Length of Stroke	30 mm (1-3/16")
Strokes Per Minute (SPM)	0 - 3,000
Capacity	Pipe: 130 mm (3-1/2") Wood: 255 mm (10")
Dimensions (L x W x H)	447x91x176 mm (17-5/8"x3-13/16"x6-15/16")
Net weight	3.2 - 3.3 kg (7.1 - 7.3 lbs.)
Power supply cord	2.5 m (8.2 ft)

JR3051TK



Recipro Saw

JR3061T



303

Continuous rating input	1,250W
Length of Stroke	32 mm (1-1/4")
Strokes Per Minute (SPM)	0 - 3,000
Capacity	Pipe: 130 mm (5-1/8") Wood: 255 mm (10")
Vibration Level	Cutting Boards: 18.5 m/s ² Cutting Wooden Beams: 16.5 m/s ²
Sound Pressure Level	88 dB(A)
Sound Power Level	99 dB(A)
Dimensions (L x W x H)	487 x 95 x 177 mm (19-3/16"x3-3/4"x7")
Net weight	3.8 kg (8.4 lbs.)
Power supply cord	2.5 m (8.2 ft)

JR3061T



Recipro Saw

JR3070CT



303

Continuous rating input	1,510W
Length of Stroke	32 mm (1-1/4")
Strokes Per Minute (SPM)	0 - 2,800
Capacity	Pipe: 130 mm (5-1/8") Wood: 255 mm (10")
Vibration Level	Cutting Boards: 9.5 m/s ² Cutting Wooden Beams: 10.5 m/s ²
Sound Pressure Level	89 dB(A)
Sound Power Level	100 dB(A)
Overall Length	485 mm (19-1/8")
Net weight	4.6 kg (10 lbs.)
Power supply cord	2.5 m (8.2 ft)

JR3070CT



Band Saw

LB1200F



Continuous rating input	900W
Capacity	Thickness of cut: 165 mm (6-1/2") Throat: 305 mm (12")
Blade speed	High: (50 Hz)1800 (60 Hz)1,000 m ((50 Hz)2,624 (60 Hz)3,280 ft) / min Low: (50 Hz)400 (60 Hz)500 m ((50 Hz)1,312 (60 Hz)1,640 ft) / min
Dimensions (L x W x H)	615x775x1,600 mm (24-1/4"x30-1/2"x63")
Net weight	82 kg (181.2 lbs.)
Power supply cord	2.5 m (8.2 ft)

LB1200F

Scroll Saw

SJ401



Continuous rating input	50W
Capacity	Thickness of cut: 50 mm (2") Throat: 406 mm (16")
Length of Stroke	18 mm (11/16")
Strokes Per Minute (SPM)	400-1,600
Overall Length	600 mm (23-5/8")
Net weight	14 kg (30.87 lbs.)

SJ401

Planning / Routing



Power Planer

1911B
110 mm (4-3/8")



Continuous rating input	
Planing Width	
Planing Depth	
No Load Speed (RPM)	
Overall Length	
Net weight	
Power supply cord	

1911B

Plate Joiner

PJ7000

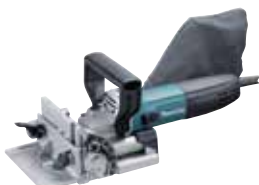

459 [mm]

Continuous rating input	701W
Blade Diameter	100 mm (4")
No Load Speed (RPM)	11,000
Dimensions (L x W x H)	302x139x145 mm (11-7/8"x5-1/2"x5-3/4")
Net weight	2.8 kg (6.2 lbs.)
Power supply cord	2.5 m (8.2 ft)

PJ7000

Planer

2012NB
304 mm (12")



153 [mm]

Continuous rating input	1,650W
Cutting Width	304 mm (12")
Cutting depth	Cutting width 0-150 mm: 3 mm (1/8") Cutting width 150-240 mm: 1.5 mm (1/16")
Feed rate/min.	8.5 m (27.9 ft)
Table Size (W x L)	304 x 771 mm (12" x 30-3/8")
No Load Speed (RPM)	8,500
Dimensions (L x W x H)	483x771x401 mm (19"x30-3/8"x15-13/16")
Net weight	27.1 - 27.6 kg (59.7 - 60.9 lbs.)
Power supply cord	2.5 m (8.2 ft)

2012NB

Trimmer

RT0700C

6 mm (1/4"), 8 mm (3/8")



411 [mm]

Continuous rating input	710W
Collet Capacity	6 mm, 8 mm or 1/4", 3/8"
No Load Speed (RPM)	10,000 - 30,000
Vibration Level	Rotation w/o Load: 2.5 m/s ² or less Cutting Grooves in MDF: 3.5 m/s ²
Sound Pressure Level	82 dB(A)
Sound Power Level	93 dB(A)
Dimensions (L x W x H)	89x89x200 mm (3-1/2"x3-1/2"x7-7/8")
Net weight	1.8 - 2.7 kg (3.9 - 6.0 lbs.)
Power supply cord	2.5 m (8.2 ft.)

RT0700C

Trimmer

3709
6 mm (1/4")



411 [mm]

Continuous rating input	530W
Collet Capacity	6 mm or 1/4"
No Load Speed (RPM)	30,000
Vibration Level	Rotation w/o Load: 2.5 m/s ² or less Cutting Grooves in MDF: 3.5 m/s ²
Sound Pressure Level	80 dB(A)
Dimensions (L x W x H)	82x90x199 mm (3-1/4"x3-1/2"x7-7/8")
Net weight	1.5 kg (3.3 lbs.)
Power supply cord	2.5 m (8.2 ft.)

3709

Router

RP2301FC
12 mm (1/2")



203 [mm]

Continuous rating input	2,100W
Collet Capacity	12 mm or 1/2"
Plunge Capacity	0 - 70 mm (0 - 2-3/4")
No Load Speed (RPM)	9,000 - 22,000
Vibration Level	Cutting Grooves in MDF: 4.5 m/s ²
Sound Pressure Level	87 dB(A)
Sound Power Level	98 dB(A)
Dimensions (L x W x H)	155x294x312 mm (6-1/8"x11-5/8"x12-1/4")
Net weight	6.1 kg (13.5 lbs.)
Power supply cord	4.0 m (13.1 ft.)

RP2301FC

Router

RP1800
12 mm (1/2")



203 [mm]

Continuous rating input	1,850W
Collet Capacity	12 mm or 1/2"
Plunge Capacity	0 - 70 mm (0 - 2-3/4")
Base dia.	170 mm (6-11/16")
No Load Speed (RPM)	22,000
Vibration Level	Cutting Grooves in MDF: 4.0 m/s ²
Sound Pressure Level	86 dB(A)
Sound Power Level	97 dB(A)
Dimensions (L x W x H)	155x294x312 mm (6-1/8"x11-5/8"x12-1/4")
Net weight	6 kg (13.2 lbs.)
Power supply cord	4.0 m (13.1 ft.)

RP1800



Chain Mortiser

7104L



153 [mm]

Continuous rating input	1,140W
Capacity	Max hole width: 130 mm (5-1/8") Max hole depth: 155 mm (6-1/8")
No Load Speed (RPM)	3,200
Dimensions (L x W x H)	512x298x513 mm (20-3/16"x11-3/4"x20-1/4")
Net weight	17.8 - 18.2 kg (39.4 - 40.1 lbs.)
Power supply cord	5.0 m (16.4 ft)

7104L



Bevel guide set

Adjustable angle of Guide Rail

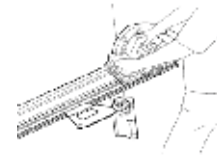

Part No.

196664-7

Stand: B



Model No.	Part No.
MLT100, 2702, 2703	JM27000300

Guide rail Joint connector 2pc set



Part No.

198884-9

198885-7(EU)

Guide rail



Overall length (m)	Part No.
1	199140-0
1.4	194368-5
1.5	199141-8
1.9	194925-9
3	194367-7



Clamp set

(Use with Guide rail)

A



B



Type	Part No.
A	194385-5
B	199826-6



Guide Rail Adaptor

Items	A	B	C	D	E	F (L)	G	H	I	J	K	L (F)	M	N	O
Models	Circular saw											Jig saw		Router Trimmer	
	DHS710 HS7100 HS7101	DHS630 HS6100 HS6101	HS7601 HS7610 HS7611	DHS680	HS6600, HS6601	HS6100 HS6101 HS7100 HS7101	HS0600	5705R	DHS660 DHS661	5903R	5103R	DJV141 DJV181 DJV142 DJV180 DJV182 4350CT 4350FCT 4350FT 4350T 4351CT 4351FCT 4351T	DJV141 DJV181 DJV142 DJV180 DJV182 4350CT 4350FCT 4350FT 4350T 4351CT 4351FCT 4351T	JV102D JV103D	*DRT50 3612BR RP0900 RP0910 RP1110C RP1800 RP1800F RP1801 RP1801F RP2300FC RP2301FC *RT0700C
Part No.	195837-9	195838-7	197005-0	196953-0	197462-2	197252-3	198566-3 198570-2(EU)	192505-5	199232-5	192506-3	192507-1	197252-3	193517-1	198704-7	194579-2
Conversion Part No.	Items B/C/D/E + 195840-0	Items A/C/D/E + 195841-8	Items A/B/D/E/F + 196994-6	Items A/B/C/E/F + 196954-8	Items A/B/C/D/F + 197463-0	Items C/D/E + 195840-0 + 195841-8						Items A,B,C,D,E + 347393-7	Item N + Bolt M5X10 922207-7	Item M Bolt M4X8 922107-1	

* Use with Plunge base assembly (P/N:195563-0 EU:196094-2)

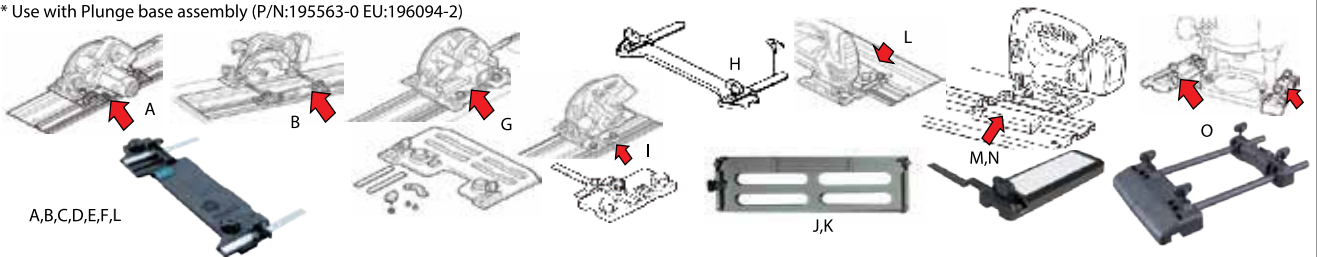

Dust Extraction

Automatic self-cleaning filter (VC2000L, VC2510L, VC3210L)

obtained by Triple filter structure composed of : Powder filter + Damper + Prefilter

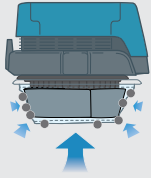

When the power is switched on, Prefilter collapses into itself to compress Damper, and fits closely over Damper and Powder filter.

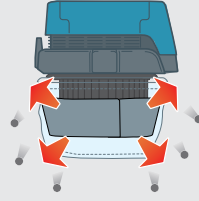

When the power is switched off, Damper expands back to its original size and shakes off dust from Prefilter automatically with its expanding power.



Dust Extraction

Allows for:

- Constantly high suction power
- Easy filter cleaning simply by tapping dust off of Prefilter
- Quiet cleaning because Damper and Prefilter make no noise

VC2510LX1

Dust Class L Vacuum Cleaner (Wet & Dry)

173

Vacuum Cleaner

new



- GYUPPA automatic self-cleaning filter of our unique design allows for constantly high suction power
- Easy filter cleaning simply by tapping dust off of prefilter
- Quiet cleaning because Damper and Prefilter make no noise
- Powerful 1,050 W motor generates 3.5 m³/min of Max air flow / 22 kPa of Max sealed suction
- Approved for Dust Class L in accordance with the EU standard



Hose, Holder 10-33, Front Cuffs (22, 24, 38), Poly bag set

Continuous rating input	1,050W
Max peak air flow	2.0 m ³ / min
Max Sealed Suction (water column)	22.0 kPa (2,240 mmH ₂ O)
Tank capacity	Dust : 25 L Water : 14 L
Dimensions (L x W x H)	432x416x451 mm (17"x16-3/8"x17-3/4")
Net weight	10.5 kg (23.2 lbs.)
Power supply cord	5.0 m (16.4 ft)

VC2510LX1

VC3210LX1

32 L Dust Class L Vacuum Cleaner (Wet & Dry)

173

Vacuum Cleaner



- GYUPPA automatic self-cleaning filter of our unique design allows for constantly high suction power
- Easy filter cleaning simply by tapping dust off of prefilter
- Quiet cleaning because Damper and Prefilter make no noise
- Powerful 1,050 W motor generates 3.5 m³/min of Max air flow / 22 kPa of Max sealed suction
- Approved for Dust Class L in accordance with the EU standard



Hose, Holder 10-33, Front Cuffs (22, 24, 38), Poly bag set

Continuous rating input	1,050W
Max peak air flow	2.0 m ³ / min
Max Sealed Suction (water column)	22.0 kPa (2,240 mmH ₂ O)
Tank capacity	Dust : 32 L Water : 27 L
Dimensions (L x W x H)	552x398x685 mm (21-3/4"x15-5/8"x27")
Net weight	14.5 kg (32 lbs.)
Power supply cord	5.0 m (16.4 ft)

VC3210LX1

VC2000L

20 L Dust Class L Vacuum Cleaner

Vacuum Cleaner



- Approved for Dust Class L in accordance with the EU standard
- Push & Clean semi-automatic filter cleaning system for extended operating time and filter life
- Convenient integrated carry handle for easier transportation
- Powerful 1,000 W motor generates 21 kPa of Max sealed suction
- 20 L Large dust bag capacity enables continuous cleaning work



Continuous rating input	1,000W
Max Sealed Suction	21.0 kPa
Tank capacity	20 L
Dimensions (L x W x H)	390x385x505 mm
Net weight	7.5 kg (N/A lbs.)
Power supply cord	5 m (16.4 ft)

VC2000L

Blower

303

UB1102













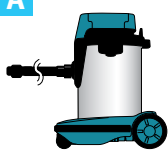

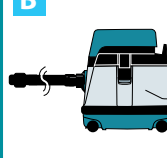

Continuous rating input	600W
Max Air Volume	4.1 m ³ /min
Max Air Velocity	91 m/s
Air Pressure	5.7 kPa
No Load Speed (RPM)	16,000
Vibration Level	Operation w/o Load: 2.5 m/s ²
Sound Pressure Level	83 dB(A)
Sound Power Level	94 dB(A)
Dimensions (L x W x H)	479x185x178 mm (18-7/8"x7-1/4"x7")
Net weight	1.9 - 2.2 kg (4.3 - 4.8 lbs.)
Power supply cord	2.5 m (8.2 ft.)









UB1102

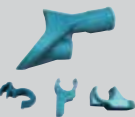











System charts

<p>A</p>  <p>W/ Ø28mm Hose</p> <p>Model VC3211H VC3211M VC2211M VC3210L</p> <p>W/ Front cuffs</p>  <p>38 24 22</p>	<p>B</p>  <p>W/ Ø28mm Hose</p> <p>Model VC2510L VC1310L DVC861L DVC863L DVC864L</p> <p>W/ Front cuffs</p>  <p>38 24 22</p>	<p>C</p>  <p>W/ Ø28mm Hose</p> <p>Model DVC350</p> <p>W/ Front cuffs</p>  <p>38 24 22</p>	<p>D</p>  <p>W/ Ø38mm Hose</p> <p>Model DVC860L DVC861L DVC862L DVC863L DVC750L</p> <p>W/ Joint 22-38</p> 	<p>E</p>  <p>W/ Ø28mm Hose</p> <p>Model DVC261 DVC265</p> <p>W/ Front cuffs</p>  <p>38 24 22</p>	<p>F</p>  <p>W/ Ø32mm Hose</p> <p>Model VC2012L VC2512L VC3011L</p> <p>W/ Tool adapter Adapter 38 (option)</p>  <p>24 P-81745 38 P-70421</p>	<p>G</p>  <p>W/ Ø32mm Hose</p> <p>Model VC3012L VC4010L VC3012M VC4010M</p> <p>W/ Tool adapter</p>  <p>24 P-70378 38 W107418688</p>
---	---	--	---	---	---	--









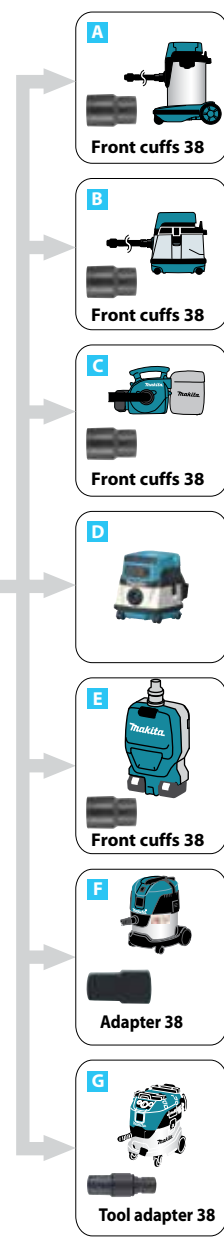



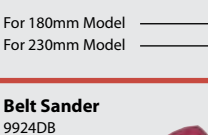
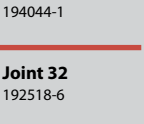

For Model	Suction Systems and Part No.
<p>Rotary Hammer, Demolition Hammer</p> <p>SDS-MAX, 17mm (11/16") Hex: Bull points with over 280mm length Cold chisels with over 280mm length</p> <p>SDS-MAX only: Scaling chisel (for tile), Bushing tool Scaling chisels length</p> <p>19mm (3/4") Hex only Scaling chisels</p> <p>17mm (11/16") Hex: HM0830, HR3530, HR4030C</p> <p>SDS-MAX: HR4001C/02/10C/11C, HR4501C/10C/11C, HR3540C/41FC, HM0870C/71C, HM1101C/11C, HM1203C/13C, HM1214C, HR4501C/10C/11C, HR4013C, HR4003C, HR3540C/41FC, DHR400, HR5202C, HR5212C, HM1205</p> <p>19mm (3/4") Hex: HR4041C</p>	<p>Dust extractor attachment set (Hammering mode only) 199144-2 (w/hose for) 199143-4 (w/o hose for)</p>  <p>ø28mm hose can be directly connected.</p>
<p>Electric Breaker HM1304/B, HM1306, HM1317C/CB, HM1307C/CB, HM1400, HM1500/B, HM1810, HM1801, HM1812, HM1802</p> 	<p>Vacuum attachment set</p>  <p>197168-2 (w/o hose for) 197148-8 (w/ hose for)</p> <p>ø28mm hose can be directly connected.</p>
	<p>A Directly</p> <p>B Directly</p> <p>C Directly</p> <p>D ø28mm hose</p> <p>E Directly</p> <p>F Tool adapter 24</p> <p>G Tool adapter 24</p>

For Model	Suction Systems and Part No.
<p>Rotary Hammer, Combination Hammer see page 150</p> <p>DHR242, HR2650, HR2651, HR2652, HR2653, HR2661, HR2663, DHR280, DHR282, HR2300, HR2600, HR2601, HR2601F, HR2630, HR2631F, HR2641, DHR243, HR2651T, HR2653T, HR2300T, HR2320T, HR2630T, HR2631FT,</p> <p>DHR164, DHR165, DHR171, DHR182, HR140D, HR166D, HR1840, HR1841F, HR2800, HR2810, HR2811F, DHR202, DHR241, DHR263, HR2230, HR2460, HR2460F, HR2470, HR2475</p> <p>DHR164, DHR165, DHR202, BHR262/T, DHR263, DHR264</p> <p>HR2470 series HR2800 series</p>	<p>Dust cup set 195173-3</p>  <p>Dust extractor attachment 193472-7</p> 
<p>Rotary Hammer HR4002, HR4011C, HR4010C, HR4001C, HR4511C, HR4510C, HR4501C</p> <p>(Max. Bit Diameter 40mm)</p> <p>DHR400, HR4013C, HR4003C, HR5212C, HR5202C</p>	<p>Vacuum attachment 195866-2</p> 
	<p>A Front cuffs 22</p> <p>B Front cuffs 22</p> <p>C Front cuffs 22</p> <p>D Joint 22-38 195548-6</p> <p>E Front cuffs 22</p> <p>F Tool adapter + Joint 25-50 192349-3</p> <p>G Tool adapter 38 + Joint 22-38 195548-6</p>

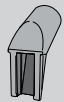
Items of standard equipment and specifications may vary by country or area.

For Model	Suction Systems and Part No.
Angle Cutter 4112H 4112HS 4114 4114S 	Elbow joint 32 192613-2 
Dustless Cutter 4105KB 	Elbow joint 32 192613-2 
Dustless Cutter 4100KB 	
Cutter With Dust Collection 4157KB 	
Wall Chaser SG1251, SG1250 	
Concrete Planer PC5000C, PC5001C PC5010C 	
Angle Grinder 	Dust collecting wheel guard For cup type diamond wheel 
For 115, 125mm Model Single notch ——— w/o mark of origin 195237-3 Triple notches ——— w/o mark of origin for IEC 195239-9 w/ mark of origin for IEC 195238-1 North America package 195236-5 North America package for UL 196575-6 For 180,230mm Model w/ mark of origin for IEC 195384-0 w/o mark of origin for IEC 195385-8 North America package for UL 197584-8 Twin notches ——— w/ mark of origin 195387-4 w/o mark of origin 195388-2 North America package 195386-6	





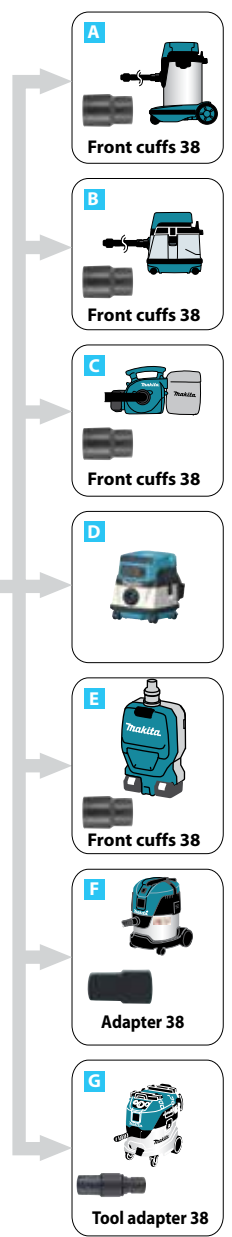













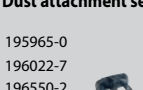

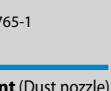

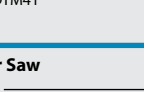
For Model	Suction Systems and Part No.
Angle Grinder 	Dust collecting wheel guard 
For 125mm Model ——— 196845-3 196846-1 	
For 230mm Model ——— 198379-2 198380-7 	
Angle Grinder 	Dust collecting wheel guard 
For 115, 125mm Model ——— 192968-5 193794-5 (Economy type) For 180mm Model ——— 194303-3 For 230mm Model ——— 194044-1	
Belt Sander 9924DB 	Joint 32 192518-6 
Belt Sander 9404, 9902, 9903, 9910, 9911, 9920, 	
Belt Sander 9403, 9921 	Joint 32 192349-3 
Wheel Sander 9741 	Joint 410899-9 









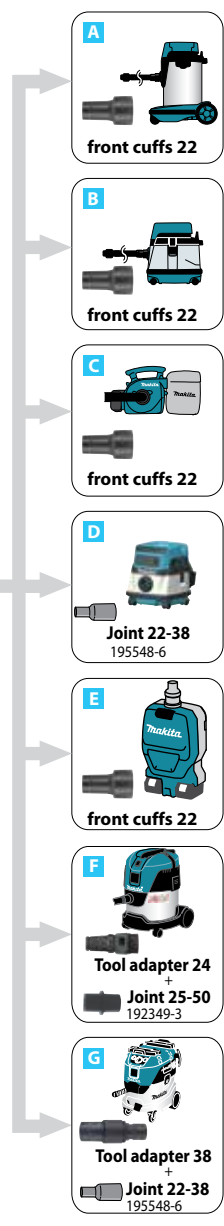







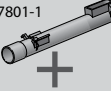

Items of standard equipment and specifications may vary by country or area.

System charts

For Model	Suction Systems and Part No.
Disc Grinder N9500N, 9500NB 	Dust collecting wheel guard 192212-0  Rubber sleeve 192202-3
Angle Grinder For 100mm Model  For 115,125mm Model	Dust collecting wheel guard Dust collecting 100C set — 198413-8 Dust collecting 100CD set — 198414-6  198415-4
Belt Sander 9032 	Dust nozzle assembly 122652-8 
Belt Sander 9031 	
Finishing Sander 9046, BO3700, BO3710, BO3711, BO4900/V, BO4901 BO4555, BO4556, BO4565, BO4566, BO4557, BO4558 	
Random Orbit Sander BO5012, BO5030, BO5031, BO5040, BO5041, BO6030, BO6040, DBO140, DBO180 	
Multi Tool DTM50, DTM40 — 195965-0 TM3000C — 196022-7 TM3010C — 196550-2  DTM51, DTM41 — 196765-1 	Dust attachment set 
Circular Saw DHS630 — 194314-8 DSS611, DSS610 — 419283-5 DSS501, DSS500 — 194415-2 HS300D, HS301D — 195334-5 	Joint (Dust nozzle) 
Jig Saw JV100D JV143D JV183D 4326, 4327, 4328, 4329 JV0600 	
Jig Saw DJV140, DJV180 4350T/CT/FCT, 4351T/CT/FCT 	Dust Nozzle 417853-4 

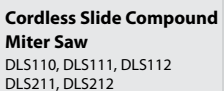









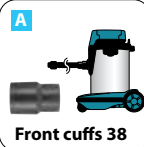



For Model	Suction Systems and Part No.
	front cuffs24 195546-0 
Circular Saw HS6100, HS6101, HS7100, HS7101 — 453289-3 DHS710, HS6600, HS6601, — 196520-1 HS7010, HS7600, HS7601, — 196843-7 HS7610, HS7611 (with short lever) HS6600, HS7000, HS7600, DHS711 — 199712-1 5007N, 5007NF (with short lever) HS0600 — 198263-1 DHS680 — 198265-7 (with short lever) 196961-1 196952-2 (with short lever) HS7000, HS7600 — 196520-1 197221-4 (with short lever)	Joint (Dust nozzle) 453289-3 196520-1 196843-7 (with short lever) 199712-1 (with short lever) 198263-1 198265-7 (with short lever) 196961-1 196952-2 (with short lever) 196520-1 197221-4 (with short lever)
	Front cuffs 24 195546-0 
Plunge Cut Circular Saw SP6000 	Front cuffs 24 195546-0 
Cordless Plunge Cut Circular Saw DSP600, DSP601 	
Aluminum Groove Cutter CA5000 	
Cordless Jig Saw DJV141, DJV142 — 126331-0 DJV181, DJV182 — 457801-1 DJV102D, JV103D 	Dust nozzle assembly 126331-0  457801-1  Front cuffs 24 195546-0
Slide Compound Saw LS1019/L, LS1219/L 	Front cuffs 24 195546-0 
Cordless Slide Compound Miter Saw DLS110, DLS111, DLS112 DLS211, DLS212 	



* not needed Front cuffs 24







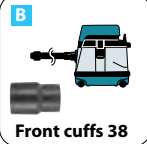

System charts

For Model	Suction Systems and Part No.
Cordless Slide Compound Miter Saw DLS713 DLS714	 <p>A Front cuffs 38</p>
Slide Compound Saw LS0714/F/FL/L LS0815F/FL LS1016L LS1017L LS1018/L LS1216/L	 <p>B Front cuffs 38</p>
Miter Saw LS1030N, LS1440	 <p>C Front cuffs 38</p>
Compound Miter Saw LS1040/F, LS1045, LS1221	 <p>D</p>
Cordless Compound Miter Saw DLS600	 <p>E</p>
Flip Over Saw LF1000	 <p>F Adapter 38</p>
Table Top Miter Saw LH1040/F LH1201FL	 <p>G Tool adapter 38</p>











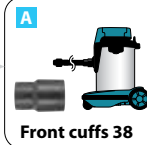
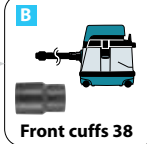





For Model	Suction Systems and Part No.
Table Saw 2704N, 2705	Joint 419093-0 
Table Saw 2703	Joint 55 192799-2 
Table Saw MLT100N	Dust point JM27000090 
Table Saw 2712	 <p>E</p>
Band Saw LB1200F	Joint 419093-0 



System charts

For Model	Suction Systems and Part No.
Circular Saw 5603R, 5704R, 5705R ——— 192420-3 5143R ——— 192490-2 5008MG ——— 450079-5 ——— 194489-3 ——— (with short lever) 5103R, 5903R ——— 192419-8 5104S, 5104 ——— 450316-7 N5900B, 5902B ——— 193823-9 ——— 193068-4 ——— (with short lever)	 Front cuffs 38  Front cuffs 38  Front cuffs 38  Adapter 38  Adapter 38  Adapter 38  Tool adapter 38
Circular Saw 5604R, 5037NB	 Adapter 38
Dustless Circular Saw 5017RKB 5057KB	 Tool adapter 38

***C: DVC350, DVC340 Cannot be used with Planer models**

For Model	Suction Systems and Part No.
Power Planer 1050D, 1051D KP0810/C	 Front cuffs 38  Front cuffs 38  Front cuffs 38  Adapter 38  Adapter 38  Adapter 38  Tool adapter 38
Power Planer DKP180, DKP140 KP0800	Nozzle 451329-1  Front cuffs 38  Adapter 38  Adapter 38  Adapter 38  Tool adapter 38
1805N ——— JPA122277	 Adapter 38
Power Planer 1911B	Nozzle for vacuum cleaner 192082-7  Adapter 38  Adapter 38  Tool adapter 38
Power Planer N1900B, N1923B, KP0800, 1804N 1805N, 1806B, KP312/S	 Tool adapter 38

***C: DVC350, DVC340 Cannot be used with Planer models**



Nozzle assembly



Joint

*Elbow









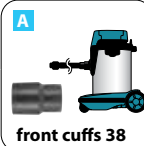
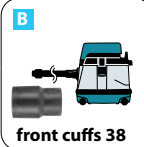

Model No.	Part No.	Model No.	Part No.
N1900B, N1923B	181572-5	N1900B, N1923B	JPA122275 (122275-2)
KP0800, DKP180, DKP140	451329-1	DKP180, DKP140, KP0810/C, KP0800	*416368-8
1804N	JPA122278 (122278-6)	1804N, 1805N, 1806B, KP312/S	181575-9
1805N	JPA122277 (122277-6)		
1806B	122397-8		
KP312/S	193733-5		

Items of standard equipment and specifications may vary by country or area.

System charts

For Model	Suction Systems and Part No.
Plate Joiner PJ7000, 3901, DPJ180, DPJ140	 <p>A front cuffs 22</p>
Cut-out Tool 3706	 <p>B front cuffs 22</p>
Dust collection cover 193449-2	 <p>C * front cuffs 22</p>
Cordless Cut-out Tool DCO180	 <p>D Joint 22-38 195548-6</p>
Cordless Drywall saw DSD180, SD100D	 <p>E front cuffs 22</p>
Router RP0910, RP1110C	 <p>F Tool adapter 24 + Joint 25-50 192349-3</p>
	 <p>G Tool adapter 38 + Joint 22-38 195548-6</p>

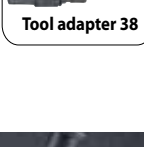
*C: DVC350 Cannot be used with Router models

For Model	Suction Systems and Part No.	
Router RP1801/ F RP1800/ F RP2301FC RP2300FC	Dust nozzle 194934-8	 <p>A front cuffs 38</p>
Router RD1100, RD1101, RF1100, RF1101, RP1100, RP1101	Dust nozzle 193379-7	 <p>B front cuffs 38</p>
Router RP0900, ***RT0700C, DRT50	Dust nozzle 194733-8	 <p>C front cuffs 38</p>
Cordless Router DRT50	*** Use with Plunge base assembly	 <p>D front cuffs 38</p>
Router RP0900, ***RT0700C, DRT50	Dust nozzle 194733-8	 <p>E front cuffs 38</p>
Cordless Router DRT50	*** Use with Plunge base assembly	 <p>F Adapter 38</p>
Router RP0910, RP1110C	Dust nozzle 195559-1	 <p>G Adapter 38</p>
Trimmer RT0700C	Dust nozzle 195559-1	 <p>G Tool adapter 38</p>
Cordless Trimmer DRT50		 <p>G Tool adapter 38</p>

Makita recommend to use 38mm hose when you use Router



Vacuum Cleaner System charts

Hose connection
28mm

Hose connection
38mm

Hose connection
32mm

For Cleaning

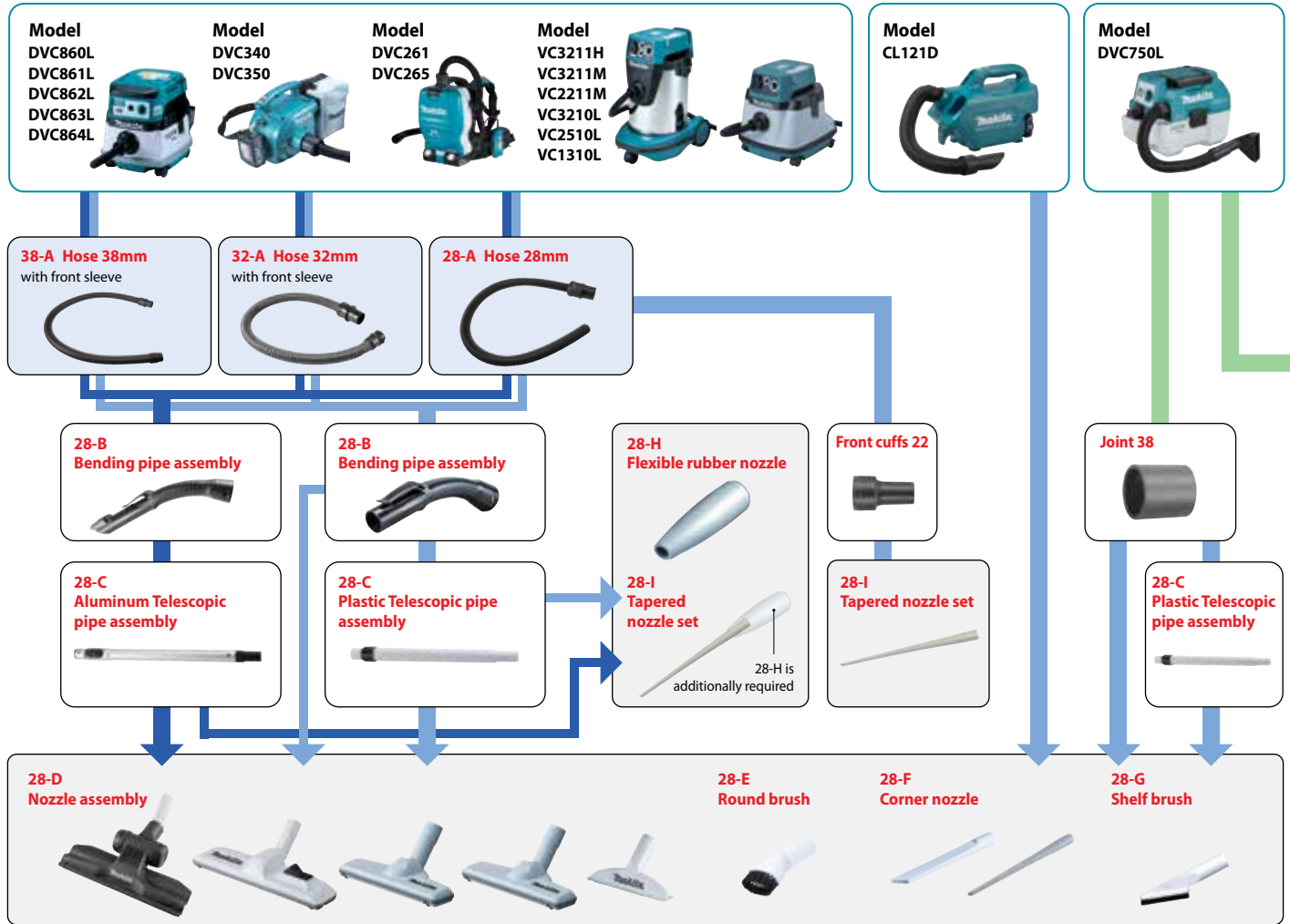

For Dust Collecting

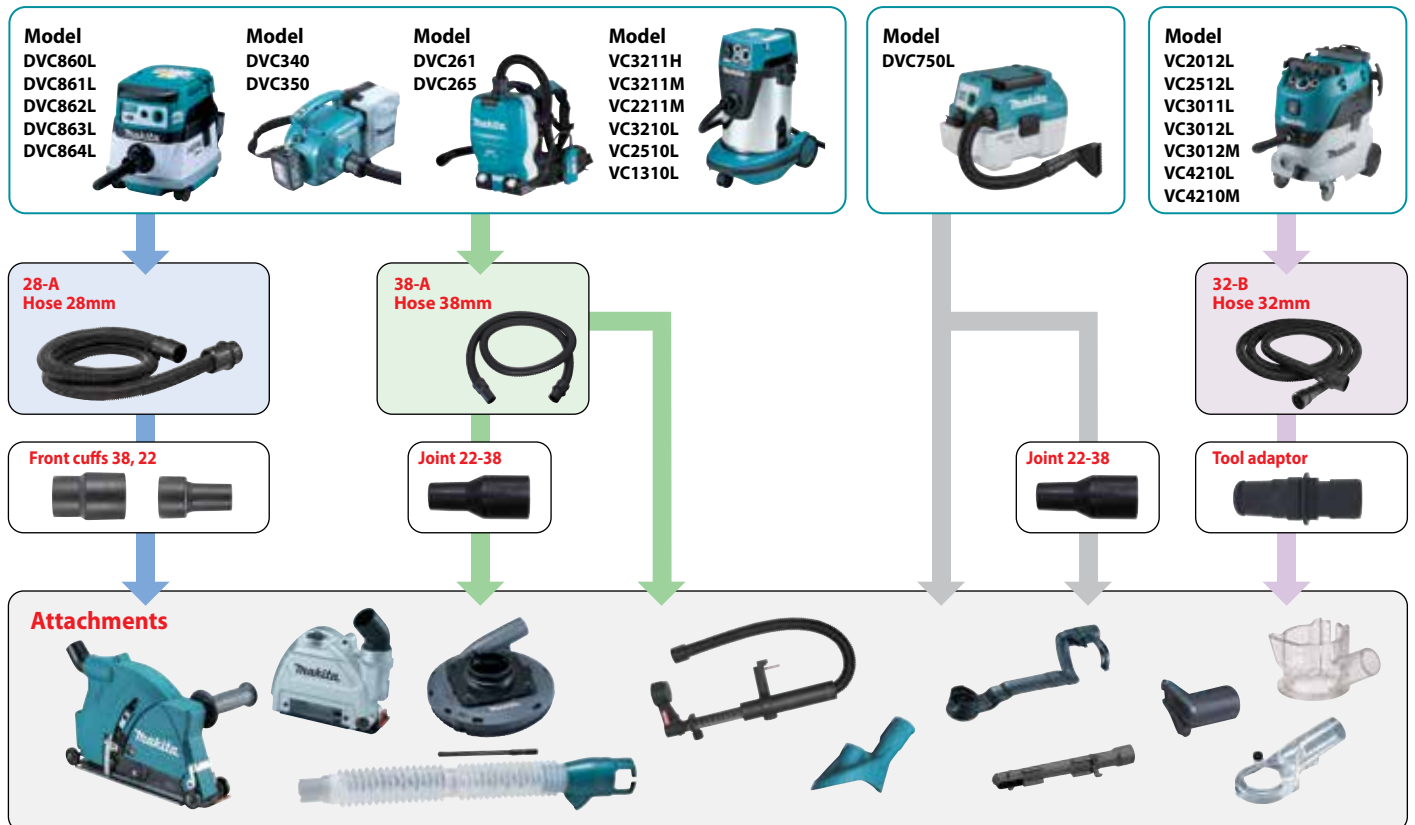

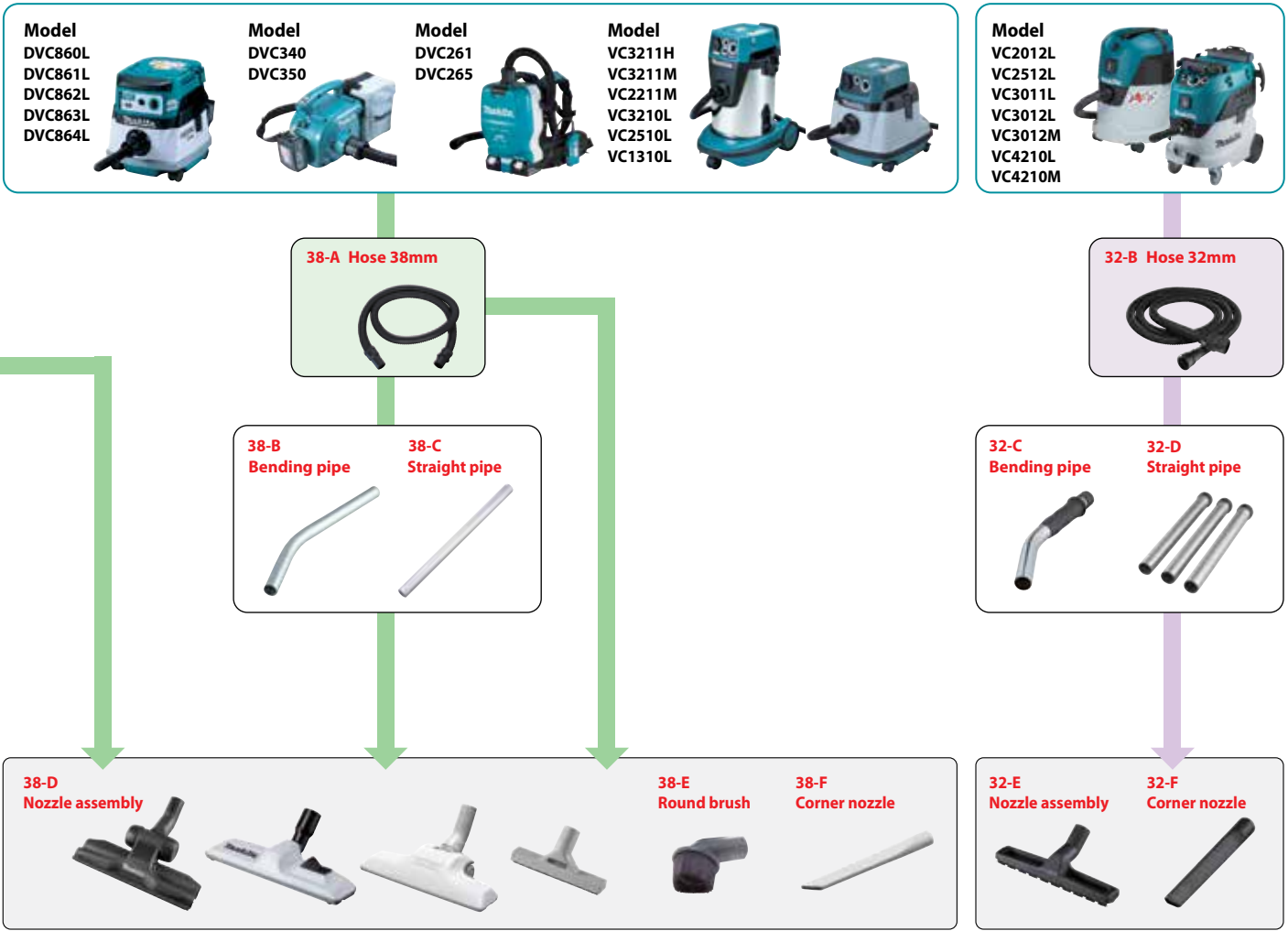

Front cuffs, Joint & Hose Connection

28-A Hose 28mm

Supplied with both Front cuffs 22 and 38

Rear cuffs (free)

Front cuffs 38: Inner dia. 38.0mm, Outer dia. 44.2mm

Front cuffs 22: Inner dia. 22.4mm, Outer dia. 25.0mm

38-A Hose 38mm

Front cuffs 38

Rear cuffs (free)

Front cuffs 38: Inner dia. 38.0mm, Outer dia. 44.2mm

Front cuffs 38, Front cuffs 22 and Front cuffs 24 connection

Hose to hose connection

28-A Hose 28 with Front cuffs 38 → 28-A Hose 28 Rear cuffs

38-A Hose 38 with Front cuffs 38 → 38-A Hose 38 Rear cuffs

Joint 22-38 connection & size

38-A Hose with with Front cuffs 38

Joint 22-38

Size: Inner dia. 22.4mm, Outer dia. 25.0mm

Pneumatic Tools



Pneumatic Brad Nailer

AF506



Capacity	Length: 15 - 50 mm (5/8" - 2")
	Gauge: 18 Ga
Operating Pressure	0.49 - 0.83 MPa (70 - 120 PSI)
Magazine Capacity	100
Dimensions (L x W x H)	250x70x256 mm (9-7/8"x3-3/4"x10-1/8")
Net weight	1.3 kg (2.9 lbs.)

AF506

Heat Gun

HG5030K



Continuous rating input	1,600W
Air Temperature (°C) /	Switch 1: 350 / 300
Flow (L/min)	Switch 2: 500 / 500
Dimensions (L x W x H)	233x80x208 mm (9-1/8"x3-1/8"x8-3/16")
Net weight	0.56 kg (1.2 lbs.)
Power supply cord	2.0 m (6.6 ft)

HG5030K

Heat Gun

HG6030K



Continuous rating input	1,800W
Air Temperature (°C) /	Switch 1: 50 / 250
Flow (L/min)	Switch 2: 300 / 250
	Switch 3: 600 / 500
Dimensions (L x W x H)	233x80x208 mm (9-1/8"x3-1/8"x8-3/16")
Net weight	0.57 kg (1.3 lbs.)
Power supply cord	2.0 m (6.6 ft)

HG6030K

Heat Gun

HG6530V



new



Continuous rating input	2,000W
Air Temperature (°C)	50 - 650
Air Flow	Stage 1: 500 L/min
	Stage 2: 280 L/min
	Stage 3: 550 L/min
Dimensions (L x W x H)	257x85x206 mm (10-1/8"x3-3/8"x8-1/8")
Net weight	0.72 kg (1.6 lbs.)
Power supply cord	2.0 m (6.6 ft)

HG6530VK

Pneumatic Stapler

AT1216AZ



Capacity	Length: 6 - 16mm (1/4" - 5/8")
Magazine capacity	Gauge: 21Ga
Operating pressure	100psi
Dimensions (L x W x H)	60 - 100PSI
	220x150x45mm
Net weight	0.9kg (1.98lbs)

AT1216AZ

Others



Laser Distance Measure

LD030P



Measuring range	0.2-30 m
Operating temperature	0 - 40 °C
Storage temperature	-25 - 70°C
Typical measuring tolerance	±2.0 mm / 10 m
Max measuring tolerance	±3.0 mm / 10 m
Diameter of laser point	6 mm / 10 m
Laser type	Laser class 2: 635 nm
Dimensions (H x D x W)	117x53x25 mm (4.5"x2.14"x1")
Net weight	0.1 kg (0.22 lbs.)

LD030P

Laser Distance Measure

LD050P



Measuring range	0.05-50 m
Power supply	Cell battery : AAA 1.5 V x 2 pcs
Net weight	0.1 kg (0.22 lbs.)

LD050P

Laser Distance Measure

LD080P



Measuring range	0.05-80 m
Power supply	Cell battery : AAA 1.5 V x 2 pcs
Net weight	0.14 kg (0.31 lbs.)

LD080P



Cross Line Laser

SK104Z



Measuring range	Up to: 15 m
Measuring range w/ detector	Up to: 60 m
Leveling accuracy	±3 mm / 10 m
Self-leveling range	±4°
Laser fan angle	Horizontal: 180° Vertical: 180°
Number of laser lines	2
Laser type	Laser class 2: 635 nm
Operating temperature	-10 - 40 °C
Net weight	0.53 kg (1.17 lbs.)

SK104Z



Cutter

MT410



Continuous rating Input	1,200W
Capacity	Max. cutting : 32mm (1-1/4")
Blade diameter	110mm (4-3/8")
No load speed (rpm)	13,000
Dimensions (L x W x H)	226x211x163mm (8-7/8"x8-5/16"x6-3/8")
Net Weight	3.0kg (6.6lbs)
Power supply cord	2.0m (6.6ft)

MT410

PRODUCTS

OUTDOOR POWER EQUIPMENT



Photo: EA5600F

A wide variety of Lithium-ion Garden Tools

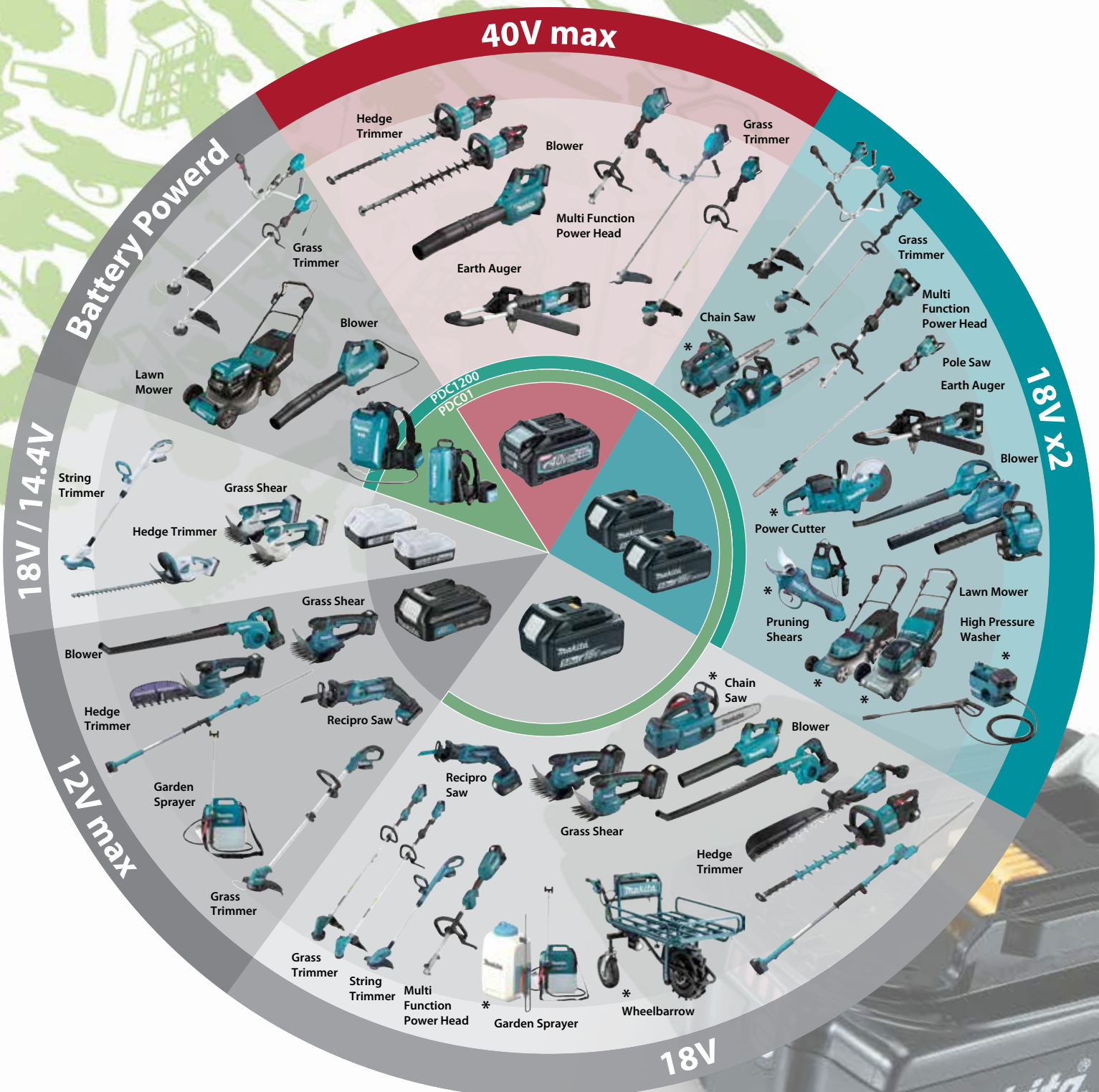

* These models are not compatible with Portable Power Pack (PDC1200, PDC01)
 Only rear handle type chainsaws are compatible



4-STROKE ENGINE

Reliable and Environment Friendly



MAKITA MINI 4-STROKE ENGINE

High Performance in Compact Design

Makita 4-Stroke Engine delivers high torque and horsepower.

Max. Torque and horsepower of Makita 4-Stroke Engine are almost the same as those of an equivalent 2-Stroke engine as shown below in the chart.

Compared with the conventional 4-Stroke Engines, Makita 4-Stroke Engine produces approximately 20 to 30 % more power thanks to its high combustion efficiency and new developments such as compact spark plug.

Additionally, by employing a unique lubrication system, it has obtained the smallest in class exterior physical dimensions among the 4-Stroke Engines available in the market today.



New compact plug



Valve system

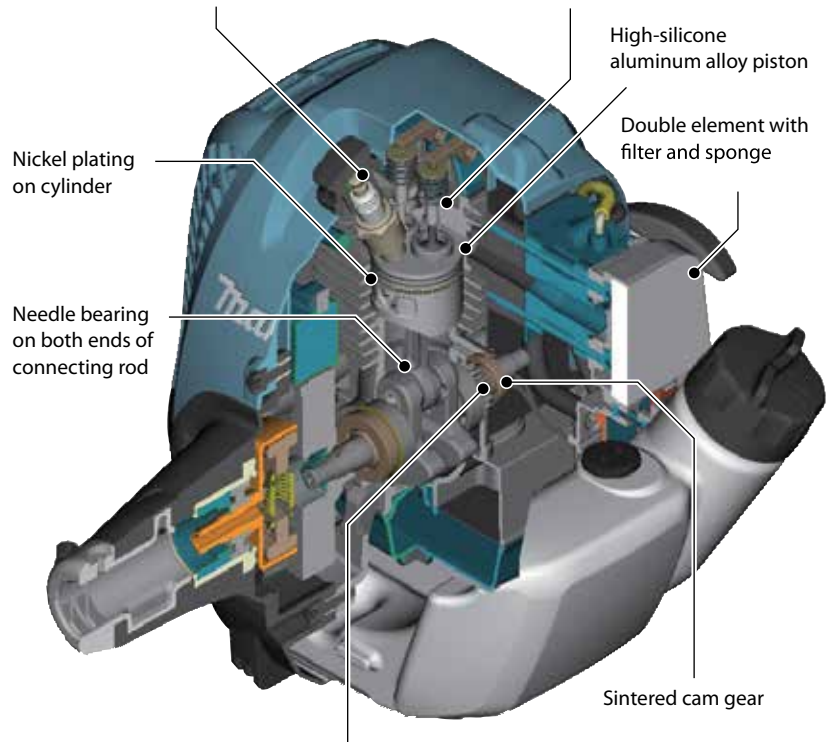

Decompression System:

The force required to pull the starter rope is drastically reduced by the Automatic decompression system that features our original centrifugal structure in the cam gear.

25mL Class			
	24.5mL 4-Stroke Engine	25.4mL 4-Stroke Engine	24.5mL 2-Stroke Engine
Max Power (PS-rpm)	0.97 / 7000	1.1 / 7000	0.98 / 7000
35mL Class			
	33.5mL 4-Stroke Engine		30.5mL 2-Stroke Engine
Max Power (PS-rpm)	1.45 / 7000		1.3 / 7000
43mL Class			
	43mL 4-Stroke Engine		42.7mL 2-Stroke Engine
Max Power (PS-rpm)	2.1 / 7000		1.8 / 7500

Patented Unique Lubrication System enables to use 4-Stroke Engine in Full Multi-position.

Employing this system enables to use 25.4mL Brushcutters on any slope such as ditch slopes, river banks or mountain woods. The natural pressure changes in the crankcase caused by the piston movement in the cylinder are harnessed to pump the oil throughout the engine.

Oil is pumped from a reservoir in the base of the engine through a network of one-way valves for reliable lubrication and long service life without the need to keep the engine level.

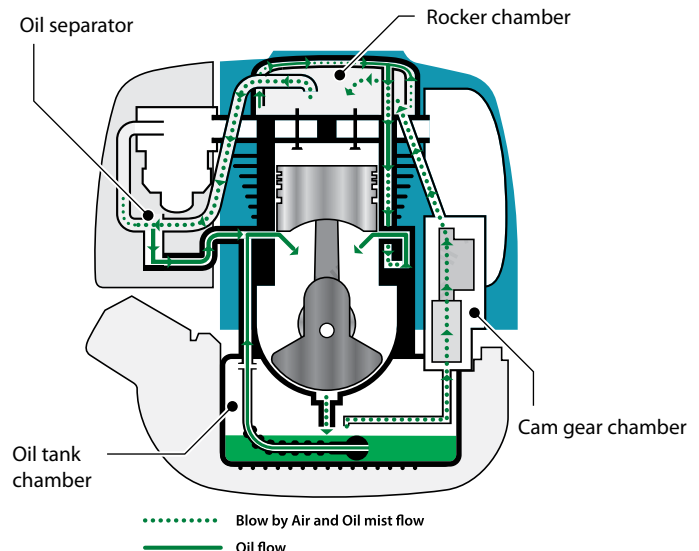

Outdoor Power Equipment

Clean Exhaust Emissions

Compared with an equivalent 2-Stroke Engine, exhaust emission is drastically reduced to comply with strict regulations in the world, including CARB Tier 3 (California, USA), EPA Phase 2 (USA) and EU Stage 2 (Europe). As shown in the table to right, the exhaust emission level of Makita 4-Stroke Engine is well below the standard level of the regulations.

	24.5mL	25.4mL	33.5mL	43.0mL	75.6mL
Certification/Standard level of Emission Gas: HC+Nox (g/kw-hr)	24.5mL < 50mL CARB/ EPA/ EU "50"	25.4mL < 50mL CARB/ EPA/ EU "50"	33.5mL < 50mL CARB/ EPA/ EU "50"	43mL < 50mL CARB/ EPA/ EU "50"	75.6mL ≥ 50mL CARB/ EPA/ EU "72"
Certificated level of Makita 4-Stroke engine: HC+Nox (g/kw-hr)	27	25	21	17	16
Certificated level of an equivalent 2-Stroke engine: HC+Nox (g/kw-hr)	240 (21mL)	205 (24.5mL)	201(30.5mL)	205(40.2mL)	204(48.6mL)

Low Running Cost

From our comparison test between Makita 4-Stroke Petrol Brushcutter and an equivalent 2-Stroke Petrol Brushcutter, the superiority of Makita 4-Stroke Engine over 2-Stroke Engine in its class has been proved both in fuel consumption and total cost as shown in the charts below.

Fuel Consumption up to 40% better

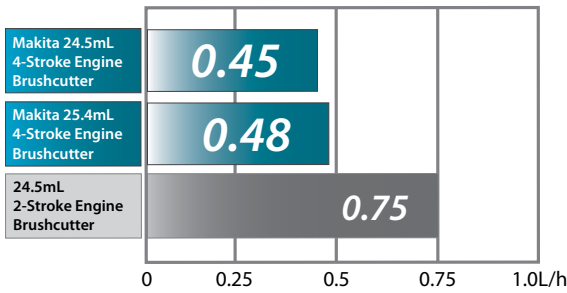

Total Cost up to 60% better (200H of Operation)

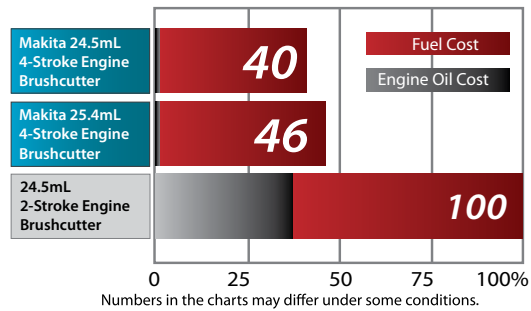

Easy Maintenance

Makita 4-Stroke Engine uses straight unleaded gasoline. Operator can, therefore, skip the following preparation and maintenance required when using 2-Stroke or 4-mix engine that runs on gas/oil mixture:

- /// Mixing gasoline and oil before operation
- /// Removing fuel from tank after operation, then sweeping dust from oil filling port*

*Removing fuel is recommended for 4-Stroke engine at the end of season.

Low Noise

Low noise level allows to operate without disturbing others even in quiet places such as parks or residential areas.



Brushcutter

Petrol Brushcutter

EM3400U
34.0 mL



Displacement	34.0 mL
Engine power	1.15 kW / 1.6 PS
Fuel Tank Capacity	0.75 L
Spindle Size	M10 x 1.25 LH
Sound Pressure Level	95 dB(A)
Sound Power Level	109.1 dB(A)
Vibration Level Left	4.4 m/s ²
Handle(Bike Handle)	
Dimensions (L x W x H)	1,815x650x435 mm (71-1/2"x25-1/2"x17-1/8")
Net weight	6.4 kg (14.1 lbs.)

EM3400U

Net weight : without guard and cutting tool

Petrol Brushcutter

EM2500U
24.5 mL



Displacement	24.5 mL
Engine power	0.73 kW / 1.0 PS
Fuel Tank Capacity	0.4 L
Spindle Size	M8 x 1.25 LH
Dimensions (L x W x H)	1,770x620x410 mm (69-3/4"x24-3/8"x16-1/8")
Net weight	4.5 kg (9.9 lbs.)

EM2500U

Net weight : without guard, cutting tool, shoulder harness and fuel

Petrol Brushcutter

RBC411U
40.2 mL



Displacement	40.2 mL
Engine power	1.40 kW / 2.0 PS
Fuel Tank Capacity	1.1 L
Spindle Size	M10 x 1.25 LH
Dimensions (L x W x H)	1,710x670x430 mm (67-1/2"x26-3/8"x17")
Net weight	7.3 kg (16.1 lbs.)

RBC411U

Net weight : without blade, harness and fuel

Electric Grass Trimmer

UR3501
350 mm (13-3/4")



Continuous rating input	1,000W
Cutting Width	350 mm (13-3/4")
No Load Speed (RPM)	7,500
Dimensions (L x W x H)	1,550x410x500 mm (61"x16-1/8"x19-3/4")
Net weight	4.3 kg (9.6 lbs.)
Power supply cord	0.35 m (1.2 ft)

UR3501

Cordless Multi Function Power Head

UX01G



No Load Speed (RPM)	High: 0 - 9,700 Medium: 0 - 8,200 Low: 0 - 5,700
Dimensions (L x W x H)	1,027 x 320 x 209 mm (40-1/2 x 12-5/8 x 8-1/4")
Net weight	4.1 - 4.7 kg (9.3 - 10.6 lbs.)

Harness, Safety Goggles, Hex Wrench, Accessory Bag, Tool bag (for spec with Brushcutter attachment only), Carbide-Tipped Saw Blade (for spec with EM402MP only), Box Wrench (for spec with EM402MP / EM403MP / EM404MP only), Metal blade fixing tool (Clamp washer, Nut, Cup) (for spec with EM402MP / EM403MP / EM404MP), Nylon Cutting Head (for spec with EM403MP / EM404MP / EM405MP / EM406MP only), Battery, Charger

Cordless Multi Function Power Head

DUX60



No Load Speed (RPM)	High: 0 - 9,700 Medium: 0 - 8,200 Low: 0 - 5,700
Dimensions (L x W x H)	1,011 x 320 x 216 mm (39-3/4 x 12-5/8 x 8-1/2")
Net weight	4.1 - 8.7 kg (8.9 - 19.2 lbs.)

DUX60ZM3
DUX60Z

Cordless Grass Trimmer

DUR190L



Cutting Width	Trimmer Head: 300 mm (11-3/4") Metal Blade: 230 mm (9") Plastic Blade: 230 mm (9")
No Load Speed (RPM)	3,500 - 6,000
Spindle Size	M8 x 1.25 LH
Dimensions (L x W x H)	1,834x348x236 mm (72-1/4"x13-3/4"x9-1/4")
Net weight	2.9 - 3.3 kg (6.5 - 7.2 lbs.)

DUR190LRT1
DUR190LZX1

Cordless Grass Trimmer

DUR190U



Cutting Width	Trimmer Head: 300 mm (11-3/4") Metal Blade: 230 mm (9") Plastic Blade: 230 mm (9")
No Load Speed (RPM)	3,500 - 6,000
Spindle Size	M8 x 1.25 LH
Dimensions (L x W x H)	1,834x610x473 mm (72-1/4"x24"x18-5/8")
Net weight	3.1 - 3.4 kg (6.7 - 7.4 lbs.)

DUR190URT1
DUR190UZX1

Cordless Grass Trimmer

DUR187L



Cutting Width	Nylon Cutting Head: 300 mm Plastic Blade: 255 mm (10")
No Load Speed (RPM)	High / Med / Low / ADT Mode: 6,000 / 5,000 / 4,000 / 4,000 - 6,000
Spindle Size	M8 x 1.25 LH
Sound Pressure Level	Nylon Cutting Head: 74 dB(A)
Sound Power Level	Nylon Cutting Head: 84 dB(A)
Vibration Level	Front / Rear: 2.5 / 2.5 m/s ² or less
Dimensions (L x W x H)	1,791x258x232 mm
Max Run Time (min)	Nylon Cutting Head, BL1860B: 168 Plastic Blade, BL1860B: 219
Net weight	3.4 - 3.7 kg (7.5 - 8.2 lbs.)

DUR187LRFE
DUR187LZ

Battery Powered Grass Trimmer

UR101C



Cutting Width	Metal Blade: 255 mm (10") Nylon Cutting Head: 430 mm (17") Plastic Blade: 305 mm (12")
No Load Speed (RPM)	High / Med / Low: 0-7,000 / 5,500 / 4,600
Spindle Size	M10 x 1.25 LH
Dimensions (L x W x H)	1,760 x 628 x 550 mm (69-1/4 x 24-3/4 x 21-5/8")
Net weight	5.2 kg (11.5 lbs.)

UR101CZ

Battery Powered Grass Trimmer

UR201C



Cutting Width	Metal Blade: 255 mm (10") Nylon Cutting Head: 430 mm (17") Plastic Blade: 305 mm (12")
No Load Speed (RPM)	High / Med / Low: 0-7,000 / 5,500 / 4,600
Spindle Size	M10 x 1.25 LH
Dimensions (L x W x H)	1,795 x 400 x 269 mm (70-1/2 x 15-3/4 x 10-5/8")
Net weight	4.7 kg (10.4 lbs.)

UR201CZ

Portable Power Pack

PDC01



new

Capacity	24 / 12 Ah
Energy Capacity	432 Wh
Dimensions (L x W x H)	400x195x132 mm (15-3/4"x7-5/8"x5-3/16")
Net weight	1.7 kg (5.6 lbs.)

Harness, Adapter

PDC01



Cordless Grass Trimmer

DUR369A

**LXT
BL
MOTOR
ADT
AFT
XPT**



new



Cutting Width	Metal Blade: 255 mm (10")
	Nylon Cutting Head: 430 mm (17")
	Plastic Blade: 305 mm (12")
No Load Speed (RPM)	L: High / Med / Low: 3,300-7,000 / 5,500 / 4,600
Spindle Size	M10 x 1.25 LH
Dimensions (L x W x H)	1,846 x 628 x 530 mm (72-1/2" x 24-3/4" x 20-7/8")
Net weight	5.9 - 6.5 kg (13.0 - 14.3 lbs.)

DUR369APT2
DUR369AZ

Cordless Grass Trimmer

UR100D

**XPT
CXT**



UR100DWAE
UR100DZ

Cutting Width	Nylon Cutting Head: 260 mm
	Plastic Blade: 230 mm
No Load Speed (RPM)	10,000
Spindle Size	M8 x 1.25 RH
Sound Pressure Level	Nylon Cutting Head: 74 dB(A)
Vibration Level Front / Rear	Nylon Cutting Head: 2.5 / 2.5 m/s ² or less
	Plastic Blade: 2.5 / 2.5 m/s ² or less
Dimensions (L x W x H)	835 - 1,185 x 267 x 210 - 315 mm (32-7/8" - 46-3/4" x 10-1/2" x 8-1/4" - 12-3/8")
Net weight	1.9 - 2.1 kg (4.3 - 4.6 lbs.)

UR100DWAE
UR100DZ

Cordless Grass Trimmer

DUR368L

**AFT
ADT
BL
MOTOR
LXT**



new



Cutting Width	Metal Blade: 255 mm (10")
	Trimmer Head: 350 mm (13-3/4")
	Plastic Blade: 255 mm (10")
No Load Speed (RPM)	High / Med / Low: 6,500 / 5,300 / 3,500
Sound Pressure Level	4-Tooth Blade: 74.7 dB(A)
Vibration Level	Left / Right: 2.5 / 2.5 m/s ² or less
	Vibration K Factor
Dimensions (L x W x H)	1,758 x 362 x 231 mm (69-1/4" x 14-1/4" x 9-1/8")
Net weight	3.9 - 4.5 kg (8.6 - 10.0 lbs.)

DUR368LPT2
DUR368LZ

Cordless Grass Trimmer

DUR368A

**AFT
ADT
BL
MOTOR
LXT**



new



Cutting Width	Metal Blade: 255 mm (10")
	Trimmer Head: 350 mm (13-3/4")
No Load Speed (RPM)	High / Med / Low: 6,500 / 5,300 / 3,500
	Plastic Blade: 255 mm (10")
Sound Pressure Level	4-Tooth Blade: 74.7 dB(A)
Vibration Level	Left / Right: 2.5 / 2.5 m/s ² or less
	Vibration K Factor
Dimensions (L x W x H)	1,758 x 362 x 231 mm (69-1/4" x 14-1/4" x 9-1/8")
Net weight	4.1 - 4.7 kg (9.0 - 10.5 lbs.)

DUR368APT2
DUR368AZ



Chain Saw

Petrol Chain Saw

EA6100P45E
380-600 mm
(15"-24")



Saw chain	Pitch : 0.325" or 3/8" Gauge: 1.5 mm (0.058")
Displacement	60.7 mL
Engine power	3.4 kW / 4.6 PS
Fuel Tank Capacity	0.8 L
Chain Oil Tank Volume	0.48 L
Sound Pressure Level	105 dB(A)
Sound Power Level	117 dB(A)
Vibration Level Front Grip	5.0 m/s ²
Vibration Level Rear Grip	4.0 m/s ²
Dimensions (L x W x H)	435x243x312 mm (17-1/8"x9-9/16"x12-1/4")
Power head weight	6.0 kg (13.2 lbs.)

EA6100P45E

Petrol Chain Saw

EA3502S40B
400 mm
(16")



Saw chain	Pitch : 3/8" Gauge: 1.1 mm (0.043") / 1.3 mm (0.050")
Displacement	35 mL
Engine power	1.7 kW / 2.4 PS
Fuel Tank Capacity	0.4 L
Chain Oil Tank Volume	0.29 L
Sound Pressure Level	100 dB(A)
Sound Power Level	110 dB(A)
Vibration Level Front Grip	4.9 m/s ²
Vibration Level Rear Grip	5.0 m/s ²
Dimensions (L x W x H)	415x269x273 mm (16-3/8"x10-5/8"x10-3/4")
Net weight	4.5 kg (9.9 lbs.)

EA3502S40B

Petrol Chain Saw

EA4301F
330, 380, 400, 450 mm
(13", 15", 16", 18")



Saw chain	Pitch : 0.325" or 3/8" Gauge: 1.3 mm (0.050")
Displacement	42.4 mL
Engine power	2.2 kW / 3.0 PS
Fuel Tank Capacity	0.48 L
Chain Oil Tank Volume	0.28 L
Sound Pressure Level	100.8 dB(A)
Sound Power Level	110 dB(A)
Vibration Level Front Grip	3.6 m/s ²
Vibration Level Rear Grip	3.2 m/s ²
Dimensions (L x W x H)	416x248x279 mm (16-3/8"x9-3/4"x11")
Power head weight	4.8 kg (10.5 lbs.)

EA4301F45B

EA4301FX1

Net weight : without Guide bar, Saw chain

Petrol Chain Saw

EA7900P
380, 450, 500, 600 mm
(15, 18, 20, 24")



Saw chain	Pitch : 3/8" Gauge: 1.5 mm (0.058")
Displacement	79 mL
Engine power	4.3 kW / 5.8 PS
Fuel Tank Capacity	0.75 L
Chain Oil Tank Volume	0.42 L
Sound Pressure Level	105.1 dB(A)
Sound Power Level	115.3 dB(A)
Vibration Level Front Grip	6.6 m/s ²
Vibration Level Rear Grip	4.5 m/s ²
Power head weight	6.3 kg (13.8 lbs.)

EA7900P60E
EA7900P45E

Petrol Chain Saw

EA7300P45E
450, 500, 600, 700 mm
(18, 20, 24, 28")



Saw chain	Pitch : 3/8" Gauge: 1.5 mm (0.058")
Displacement	73 mL
Engine power	4.0 kW / 5.4 PS
Fuel Tank Capacity	0.75 L
Chain Oil Tank Volume	0.42 L
Sound Pressure Level	105.1 dB(A)
Sound Power Level	115.3 dB(A)
Vibration Level Front Grip	6.2 m/s ²
Vibration Level Rear Grip	4.1 m/s ²
Power head weight	6.3 kg (13.8 lbs.)

EA7300P45E

Petrol Chain Saw

DCS9010
500, 600, 740 mm
(20, 24, 29")



Saw chain	Pitch : 3/8" Gauge: 1.5 mm (0.058")
Displacement	90 mL
Engine power	4.2 kW / 5.7 PS
Fuel Tank Capacity	1 L
Chain Oil Tank Volume	0.4 L
Sound Pressure Level	103 dB(A)
Sound Power Level	114 dB(A)
Vibration Level Front Grip	6.6 m/s ²
Vibration Level Rear Grip	4.5 m/s ²
Power head weight	8.2 kg (18.1 lbs.)

DCS9010

Electric Chain Saw

UC4041A
400 mm (16")



Continuous rating input	1,800W
Chain speed per minute	870 m (2,900 ft)
Guide Bar Length	400 mm (16")
Saw chain	Pitch : 3/8" Gauge: 1.1 mm (0.043") / 1.3 mm (0.050")
Sound Pressure Level	90.3 dB(A)
Sound Power Level	101.3 dB(A)
Vibration Level	4.7 m/s ²
Dimensions (L x W x H)	455x245x200 mm (17-7/8"x9-5/8"x7-7/8")
Net weight	4.8 - 4.9 kg (10.5 - 10.7 lbs.)
Power supply cord	0.3 m (0.98 ft)

UC4041A

Dimensions : excluding blade and guide bar

Electric Chain Saw

UC4550A
450 mm (18")

new



Continuous rating input	2,000W
Chain speed per minute	870 m (2,900 ft)
Guide Bar Length	450 mm (18")
Saw chain	Pitch : 3/8" Gauge: 1.3 mm (0.050")
Sound Pressure Level	90.3 dB(A)
Sound Power Level	101.8 dB(A)
Vibration Level	5.2 m/s ²
Dimensions (L x W x H)	505x196x220 mm (19-7/8"x7-3/4"x8-5/8")
Net weight	5.7 kg (12.5 lbs.)
Power supply cord	0.3 m (0.98 ft)

UC4550A

Dimensions : excluding blade and guide bar

Cordless Chain Saw

DUC353
350 mm (14")



Guide Bar Length	350 mm (14")
Cutting Length	330 mm (13")
Chain Pitch	3/8"
Chain Gauge	1.1 / 1.3 mm (0.043" / 0.050")
Chain Speed	0-20 m/s (0-1,200 m/min) (0-3,940 FPM)
Chain Oil Tank Volume	200 mL
Sound Pressure Level	87.7 dB(A)
Sound Power Level	100.4 dB(A)
Vibration Level	Cutting Wood: 5.3 m/s ²
Dimensions (L x W x H)	762x215x235 mm (30"x8-1/2"x9-1/4")
Net weight	4.7 - 5.3 kg (10.4 - 11.7 lbs.)

DUC353Z

Cordless Chain Saw

DUC355
350 mm (14")



Guide Bar Length	350 mm (14")
Cutting Length	330 mm (13")
Chain Pitch	3/8"
Chain Gauge	1.1 mm (0.043")
Chain Speed	0-20 m/s (0-1,200 m/min)
Chain Oil Tank Volume	0-3,940 FPM)
Sound Pressure Level	200 mL
Sound Power Level	87.7 dB(A)
Vibration Level	100.4 dB(A)
Dimensions (L x W x H)	Cutting Wood: 5.3 m/s ² 762x211x235 mm
Net weight	(30"x8-5/16"x9-1/4") 4.7 - 5.4 kg (10.4 - 11.8 lbs.)

DUC355Z

Cordless Chain Saw

DUC356
350 mm
(14")

new



Guide Bar Length	350 mm (14")
Cutting Length	350 mm (14")
Chain Pitch	3/8"
Chain Gauge	1.3 mm (0.05")
Chain Speed	0-20 m/s (0-1,200 m/min)
Chain Oil Tank Volume	200 mL (6.8 US oz)
Sound Pressure Level	89 dB(A)
Sound Power Level	103 dB(A)
Vibration Level	Cutting Wood: 3.2 m/s ²
Dimensions (L x W x H)	270-651x205x232 mm (10-5/8"-25-5/8"x8-1/8"x9-1/8")
Net weight	4.6-5.1 kg (10.1 - 11.1 lbs.)

DUC356PT2

DUC356Z

Cordless Chain Saw

DUC254
250 mm (10")



Guide Bar Length	250 mm (10")
Chain Pitch / Chain	3/8" / 1.1 mm (0.043")
Gauge	3/8" / 1.3 mm (0.050")
Chain Speed	0 - 24 m/s (0 - 1,440 m/min) (0 - 4,720 FPM)
Chain Oil Tank Volume	140 mL
Sound Pressure Level	92.2 dB(A)
Sound Power Level	103.2 dB(A)
Vibration Level	2.5 m/s ²
Dimensions (L x W x H)	305x43x106 mm (12"x1-11/16"x4-3/16")
Net weight	0.77 - 0.82 kg (1.7 - 1.8 lbs.)

DUC254Z

Battery Powered Pruning Shears

DUP361



Capacity	Max cutting : 33 mm
	Max blade opening: 54 mm
Sound Pressure Level	70 dB(A) or less
Vibration Level	2.5 m/s ² or less
Dimensions (L x W x H)	305x43x106 mm (12"x1-11/16"x4-3/16")
Net weight	0.8 kg (1.8 lbs.)

DUP361Z

Battery Powered Pruning Shears

DUP362



Capacity	Max cutting : 33 mm (1-5/16")
	Max blade opening: 54 mm
Sound Pressure Level	70 dB(A) or less
Vibration Level	2.5 m/s ² or less
Dimensions (L x W x H)	305x43x106 mm (12"x1-11/16"x4-3/16")
Net weight	0.77 - 0.82 kg (1.7 - 1.8 lbs.)

DUP362PT2
DUP362Z

Telescopic Petrol Pole Saw

EY2650H25H
25.4 mL 4-stroke
(Multi-position)



Displacement	25.4 mL
Engine power	0.77 kW / 1.1 PS
Fuel Tank Capacity	0.6 L
Guide Bar Length	255 mm (10")
Saw chain	Gauge: 1.3 mm (0.050") Pitch: 3/8"
Sound Pressure Level	89.5 dB(A)
Sound Power Level	107.3 dB(A)
Vibration Level Left	7.2 m/s ²
Handle	
Vibration Level Right	5.3 m/s ²
Handle	
Dimensions (L x W x H)	2,720x223x240 mm (107"x8-3/4"x9-1/2")
Net weight	7.2 kg (16.0 lbs.)

Net weight : without harness and fuel

EY2650H25H

Hedge Trimmer

Petrol Hedge Trimmer

EH6000W
600 mm (23-5/8")



Blade Length	600 mm (23-5/8")
Displacement	22.2 mL
Engine power	0.68 kW / 1.0 PS
Fuel Tank Capacity	0.4 L
Strokes Per Minute (SPM)	4390
Tooth Spacing	35 mm (1-3/8")
Sound Pressure Level	92.8 dB(A)
Sound Power Level	103.2 dB(A)
Vibration Level Front Grip	2.8 m/s ²
Vibration Level Rear Grip	2.7 m/s ²
Dimensions (L x W x H)	1,119x262x216 mm (44"x10-3/8"x8-1/2")
Net weight	5 kg (11 lbs.)

EH6000W

Net weight : without fuel

Petrol Hedge Trimmer

EH5000W
500 mm (19-3/4")



Blade Length	500 mm (19-3/4")
Displacement	22.2 mL
Engine power	0.68 kW / 1.0 PS
Fuel Tank Capacity	0.4 L
Strokes Per Minute (SPM)	4390
Tooth Spacing	35 mm (1-3/8")
Sound Pressure Level	93.0 dB(A)
Sound Power Level	103.0 dB(A)
Vibration Level Front Grip	2.5 m/s ²
Vibration Level Rear Grip	2.5 m/s ²
Dimensions (L x W x H)	1,014x262x216 mm (40"x10-3/8"x8-1/2")
Net weight	4.8 kg (10.5 lbs.)

EH5000W

Net weight : without fuel

Petrol Hedge Trimmer

EH7500W
750 mm (29-1/2")



Blade Length	750 mm (29-1/2")
Displacement	22.2 mL
Engine power	0.68 kW / 1.0 PS
Fuel Tank Capacity	0.4 L
Strokes Per Minute (SPM)	4390
Tooth Spacing	35 mm (1-3/8")
Sound Pressure Level	93.9 dB(A)
Sound Power Level	103.8 dB(A)
Vibration Level Front Grip	2.3 m/s ²
Vibration Level Rear Grip	2.3 m/s ²
Dimensions (L x W x H)	1,259x262x216 mm (49-1/2"x10-3/8"x8-1/2")
Net weight	5.2 kg (11.4 lbs.)

EH7500W

Net weight : without fuel

Petrol Hedge Trimmer

EH7500SX
600 mm (23-5/8")



Blade Length	600 mm (23-5/8")
Displacement	22.2 mL
Engine power	0.68 kW / 1.0 PS
Fuel Tank Capacity	0.4 L
Strokes Per Minute (SPM)	4390
Tooth Spacing	35 mm (1-3/8")
Sound Pressure Level	94.3 dB(A)
Sound Power Level	101.8 dB(A)
Vibration Level Front Grip	3.5 m/s ²
Vibration Level Rear Grip	3.2 m/s ²
Dimensions (L x W x H)	1,010x323x212 mm (39-3/4"x12-3/4"x8-3/8")
Net weight	4.7 kg (10.4 lbs.)

EH7500SX

Net weight : without blade, band, and fuel

Hedge Trimmer

UH4261
420 mm (16-1/2")



Continuous rating input	400W
Blade Length	420 mm (16-1/2")
Strokes Per Minute (SPM)	3,200
Tooth Spacing	15 mm (9/16")
Sound Pressure Level	82 dB(A)
Sound Power Level	93 dB(A)
Vibration Level	6.7 m/s ²
Dimensions (L x W x H)	821x194x194 mm (32-1/4"x7-5/8"x7-5/8")
Net weight	2.9 kg (6.5 lbs.)
Power supply cord	0.3 m (0.98 ft)

UH4261

Hedge Trimmer

UH5261
520 mm (20-1/2")



Continuous rating input	400W
Blade Length	520 mm (20-1/2")
Strokes Per Minute (SPM)	3,200
Tooth Spacing	15 mm (9/16")
Sound Pressure Level	82 dB(A)
Sound Power Level	93 dB(A)
Vibration Level	6.7 m/s ²
Dimensions (L x W x H)	921x194x194 mm (36-1/4"x7-5/8"x7-5/8")
Net weight	3 kg (6.7 lbs.)
Power supply cord	0.3 m (0.98 ft)

UH5261

Hedge Trimmer

UH6570
650 mm (25-1/2")



Continuous rating input	550W
Blade Length	650 mm (25-1/2")
Strokes Per Minute (SPM)	3,200
Tooth Spacing	18 mm (11/16")
Sound Pressure Level	89.9 dB(A)
Sound Power Level	97.9 dB(A)
Vibration Level	6.7 m/s ²
Dimensions (L x W x H)	1,042x223x206 mm (41"x8-3/4"x8-1/8")
Net weight	3.8 - 3.9 kg (8.4 - 8.5 lbs.)
Power supply cord	0.3 m (0.98 ft)

UH6570

18V

Cordless Hedge Trimmer

DUH604S 600 mm (23-5/8") / DUH754S 750 mm (29-1/2")

new



18V LXT BL Brushless Cordless Hedge Trimmer

DUH604S

Blade Length: 600 mm (23-5/8")

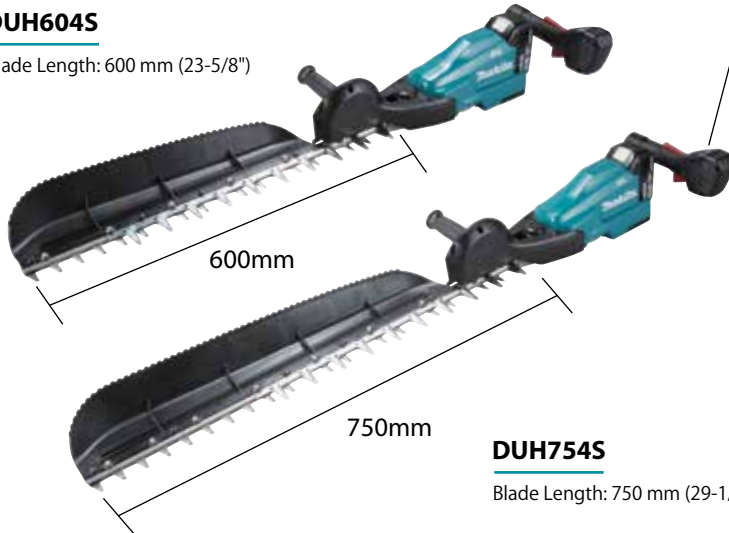

Variable 3-speed



- High : 0-4,400 SPM
- Medium : 0-3,600 SPM
- Low : 0-2,000 SPM



Reverse rotation system

for freeing the blade when it is jammed by thick branches.



DUH754S

Blade Length: 750 mm (29-1/2")

Light weight

4.0kg

with BL1850B (5.0Ah)
battery

High speed

strokes per minute

4,400min⁻¹

High speed mode
(No load speed)

DUH604

18V LXT BL Brushless Cordless Hedge Trimmer

Cordless Hedge Trimmer

new



- Excellent balance of high power and lightweight maneuverability
- 3-speed (High: 4,400, Medium: 3,600, Low: 2,000 SPM) design for optimum speed control
- Reverse rotation system frees the blade when it is jammed by thick branches
- BL motor delivers 4,400 SPM for faster cutting
- Constant speed control maintains constant speed under load
- Low noise; Noise emission is lower than engine hedge trimmers
- Chip receiver optimized for the cutting width



Blade Cover, Safety Goggles (country-specific), Chip Receiver (country-specific), Battery, Charger

Blade Length	600 mm (23-5/8")
Max Cutting Capacity	23.5 mm (15/16")
Sound Pressure Level	79.3 dB(A)
Sound power level	90.3 dB (A)
Vibration Level	2.5 m/s ² or less
Strokes Per Minute (SPM)	High / Med / Low: 0 - 4,400 / 0 - 3,600 / 0 - 2,000
Dimensions (L x W x H)	1,057x280x147 mm (41-1/2"x11"x5-3/4")
Net weight	4.0 kg (8.8 lbs.)

DUH604SRT
DUH604SZ

DUH754

18V LXT BL Brushless Cordless Hedge Trimmer

Cordless Hedge Trimmer

new



- Optimum blade shape for smooth cutting
- Twigs are caught easily and held firmly
- Anti-Vibration Structure
- consisting of Motor-crank section and handle section linked by 5 cushions to absorb vibration from blade and motor-crank section
- Ideal for pruning application
- Locks at 45° and 90° left and right and 0°.
- Makes vertical and angled trimming easier and faster.



Blade Cover, Safety Goggles (country-specific), Chip Receiver (country-specific), Battery, Charger

Blade Length	750 mm (29-1/2")
Max Cutting Capacity	23.5 mm (15/16")
Sound Pressure Level	80.6 dB(A)
Sound power level	91.6 dB (A)
Vibration Level	2.5 m/s ² or less
Strokes Per Minute (SPM)	High / Med / Low: 0 - 4,400 / 0 - 3,600 / 0 - 2,000
Dimensions (L x W x H)	1,198x280x147 mm (47-1/4"x11"x5-3/4")
Net weight	4.1 kg (9.0 lbs.)

DUH754SRT
DUH754SZ

Cordless Hedge Trimmer

DUH502 500 mm (19-3/4") / DUH602 600 mm (23-5/8") / DUH752 750 mm (29-1/2")

18V LXT BL Brushless Cordless Hedge Trimmer

Light weight

3.8kg

with BL1850B (5.0Ah) battery

High speed

strokes per minute

4,400min⁻¹

High speed mode (No load speed)

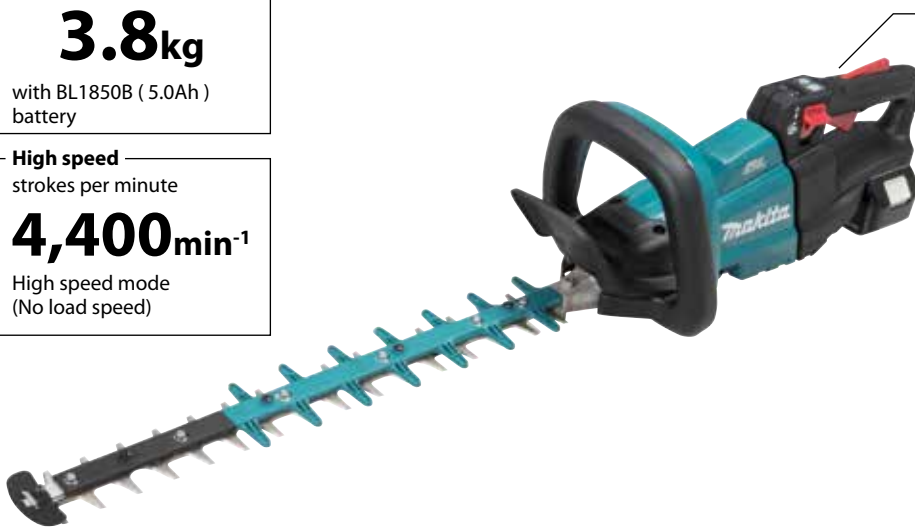

Variable 3-speed



- High : 0-4,400 SPM
- Medium : 0-3,600 SPM
- Low : 0-2,000 SPM

BL MOTOR

High Power and High Speed



DUH501 / DUH601 / DUH751

Optimum blade shape for smooth cutting



Sharp edge blades :
Upper blade...curving downward
Lower blade...curving upward

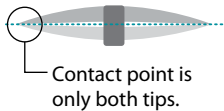

Twigs are caught easily and held firmly

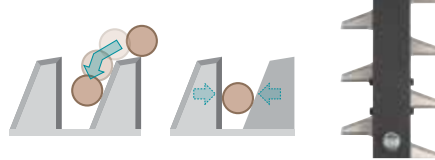

DUH502 / DUH602 / DUH752

Standard blade



Anti-vibration structure

consisting of Motor-crank section and handle section linked by 5 cushions to absorb vibration from blade and motor-crank section

Anti-vibration structure

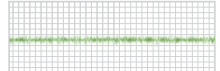

Predecessor model

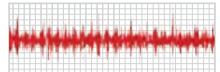

Reverse rotation system

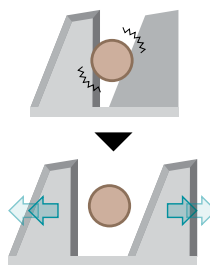

5 position rotating rear handle

- Locks at 45° and 90° left and right and 0°.
- Makes vertical and angled trimming easier and faster.



18V LXT BL Brushless Cordless Hedge Trimmer

	DUH502	DUH602	DUH752
Blade Length	500 mm (19-3/4")	600 mm (23-5/8")	750 mm (29-1/2")
Max Cutting Capacity			21.5 mm (7/8")
Strokes Per Minute (SPM)	High / Med / Low: 0 - 4,400 / 0 - 3,600 / 0 - 2,000	High / Med / Low: 0 - 4,400 / 0 - 3,600 / 0 - 2,000	High / Med / Low: 0 - 4,400 / 0 - 3,600 / 0 - 2,000
Max Output		520 W	
Dimensions (L x W x H)	1,016x192x225 mm (40"x7-1/2"x8-7/8")	1,121x192x225 mm (44-1/8"x7-1/2"x8-7/8")	1,261x192x225 mm (49-5/8"x7-1/2"x8-7/8")
Net weight	3.8 - 4.1 kg (8.3 - 9.0 lbs.)	3.9 - 4.3 kg (8.5 - 9.4 lbs.)	4.1 - 4.4 kg (9.0 - 9.7 lbs.)

	DUH502RT DUH502Z	DUH602RT DUH602Z	DUH752RT DUH752Z
--	---------------------	---------------------	---------------------



Blade Cover, Safety Goggles (country-specific)

Cordless Hedge Trimmer

DUH651
650 mm (25-1/2")



442

Blade Length	650 mm (25-1/2")
Strokes Per Minute (SPM)	2,000 - 3,600
Tooth Spacing	36 mm (1-7/16")
Sound Pressure Level	82 dB(A)
Sound Power Level	91.1 dB(A)
Vibration Level	2.5 m/s ² or less
Dimensions (L x W x H)	1,135x225x200 mm (44-3/4"x8-7/8"x7-7/8")
Net weight	4.7 - 5.5 kg (10.3 - 12.0 lbs.)

DUH651Z

Cordless Hedge Trimmer

UH201D
200 mm (7-7/8")



Blade Length	200 mm (7-7/8")
Tooth Spacing	26 mm (1")
Strokes Per Minute (SPM)	2,500
Continuous Use (min.)	w/ BL1041B / BL1021B / BL1016: 90 / 45 / 35 min
Sound Pressure Level	74 dB(A)
Vibration Level	2.5 m/s ² or less
Dimensions (L x W x H)	504x120x131 mm (19-7/8"x4-3/4"x5-1/8")
Net weight	1.3 - 1.5 kg (2.9 - 3.3 lbs.)

UH201DWY
UH201DZ



Cordless Grass Shear

DUM604
160 mm (6-5/16")



Cutting Width	160 mm (6-5/16")
Depth Adjustment	15, 20, 25 mm (9/16", 13/16", 1")
Strokes Per Minute (SPM)	2,500
Continuous Use (min.)	w/ BL1860B / BL1850B / BL1840B / BL1830B / BL1820B / BL1815N: 250 / 200 / 160 / 125 / 80 / 60
Sound Pressure Level	76 dB(A)
Vibration Level	2.5 m/s ² or less
Dimensions (L x W x H)	353x176x130 mm (13-7/8"x6-15/16"x5-1/8")
Net weight	1.4-1.8 kg (3.0 lbs.)

DUM604SY
DUM604Z

Petrol Pole Hedge Trimmer

Petrol Pole Hedge Trimmer

EN5950SH
25.4 mL 4-stroke (Multi-position)



Displacement	25.4 mL
Engine power	0.77 kW / 1.1 PS
Fuel Tank Capacity	0.6 L
Strokes Per Minute (SPM)	4,200
Sound Pressure Level	87.1 dB(A)
Sound Power Level	88.0 dB(A)
Vibration Level Front Grip	6.8 m/s ²
Vibration Level Rear Grip	9.6 m/s ²
Dimensions (L x W x H)	1,780x242x241 mm (70"x9-1/2"x9-1/2")
Blade Length	590 mm (23-1/4")
Net weight	6.0 kg (13.2 lbs.)

EN5950SH

Net weight : without harness and fuel

Petrol Pole Hedge Trimmer

EN7350SH
25.4 mL 4-stroke (Multi-position)



Displacement	25.4 mL
Engine power	0.77 kW / 1.1 PS
Fuel Tank Capacity	0.6 L
Strokes Per Minute (SPM)	4,200
Sound Pressure Level	99.6 dB(A)
Sound Power Level	100.3 dB(A)
Vibration Level Front Grip	5.9 m/s ²
Vibration Level Rear Grip	8.8 m/s ²
Dimensions (L x W x H)	1,910x259x241 mm (75-1/4"x10-1/4"x9-1/2")
Blade Length	730 mm (28-3/4")
Net weight	6.5 kg (14.3 lbs.)

EN7350SH

Net weight : without harness and fuel



Lawn Mower

Petrol Lawn Mower

PLM4620N2
460 mm (18-1/8")



Engine	B&S625E R/S, 150 mL
Engine power	2.2 kW / PS
Cutting Width	460 mm (18-1/8")
Cutting Height	25 - 70 mm (1" - 2-3/4")
No Load Speed (RPM)	2,800
Recommended mowing area up to	1,200 m ²
Fuel Tank Capacity	0.8 L
Oil Tank Capacity	0.47 L
Guaranteed Sound Pressure Level	82.0 dB(A)
Measured Sound Power Level	92.1 dB(A)
Guaranteed Sound Power Level	96 dB(A)
Vibration Level	1.89 m/s ²
Dimensions (L x W x H)	800x540x400 mm (31-1/2"x21-1/4"x15-3/4")
Net weight	27.6 kg (60.9 lbs.)

PLM4620N2

Petrol Lawn Mower

PLM4625NP
460 mm (18-1/8")



Engine	B&S625E R/S, 150 mL
Engine power	2.2 kW / PS
Cutting Width	460 mm (18-1/8")
Cutting Height	20 - 75 mm (13/16" - 2-15/16")
No Load Speed (RPM)	3,000
Recommended mowing area up to	1,200 m ²
Fuel Tank Capacity	0.8 L
Oil Tank Capacity	0.47 L
Guaranteed Sound Pressure Level	82.0 dB(A)
Measured Sound Power Level	92.1 dB(A)
Guaranteed Sound Power Level	96 dB(A)
Vibration Level	1.89 m/s ²
Dimensions (L x W x H)	795x540x560 mm (31-1/4"x21-1/4"x22")
Net weight	29 kg (64 lbs.)

PLM4625NP

Cordless Lawn Mower

DLM533
530 mm (21") Self-Propelled



Cutting Width	534 mm (21")
Cutting Height	20 - 100 mm (13/16" - 3-15/16")
No Load Speed (RPM)	2,300 - 2,800
Propelling speed	2.5 - 5.0 km/h
Dimensions (L x W x H)	1,655-1,740x590x990-1,190 mm (65"-68-1/2"x23-1/4"x39"-46-3/4")
Net weight	42.8 - 46.7 kg (94.4 - 103 lbs.)

DLM533PT4
DLM533Z

Cordless Lawn Mower

DLM532
534 mm (21") Self-Propelled



new

Cutting Width	534 mm (21")
Cutting Height	20-100 mm (13/16-3-15/16")
No Load Speed (RPM)	2,300-2,800
Propelling speed	2.5-5.0 km/h
Dimensions (L x W x H)	1,630-1,715 x 590 x 990-1,095 mm (64"-67-1/2 x 23-1/4 x 39"-43")
Net weight	39.0-42.8 kg (86.0-94.4 lbs.)

DLM532PT4
DLM532Z

Cordless Lawn Mower

DLM530
534 mm (21")



new

Cutting Width	534 mm (21")
Cutting Height	20-100 mm (13/16-3-15/16")
No Load Speed (RPM)	2,300-2,800
Dimensions (L x W x H)	1,630-1,715 x 590 x 990-1,095 mm (64"-67-1/2 x 23-1/4 x 39"-43")
Net weight	35.5-39.3 kg (78.3-86.6 lbs.)

DLM530PT4
DLM530Z

Cordless Lawn Mower

DLM462
460 mm (18") Self-Propelled



new

Cutting Width	460 mm (18")
Cutting Height	20-100 mm (13/16-3-15/16")
No Load Speed (RPM)	2,500-3,300
Propelling speed	2.5-5.0 km/h
Dimensions (L x W x H)	1,610-1,690 x 535 x 980-1,095 mm (63-1/2"-66-1/2 x 21 x 38-1/2"-43")
Net weight	35.3-39.0 kg (77.8-86.0 lbs.)

DLM462PT4
DLM462Z

Cordless Lawn Mower

DLM460
460 mm (18")



DLM460PT2
DLM460Z

Blade Type	2 Tooth
Hole Diameter	10.0 mm (3/8")
Cutting Width	460 mm (18")
Cutting Height	20-75 mm (13/16"-2-5/16")
No Load Speed (RPM)	2,500-3,300
Recommended mowing area	w/ BL1860B x2: 800-1,600 m ² w/ BL1850B x2: 680-1,360 m ² w/ BL1830B x2: 380-760 m ² w/ BL1860B/BL1850B/BL1840B/BL1830B/BL1820B/BL1815N: 21/18/14/10/8/6
Continuous Use (min.)	BL1815N: 21/18/14/10/8/6
Sound Pressure Level	79 dB(A)
Sound Power Level	91 dB(A)
Vibration Level	2.5 m/s ² or less
Dimensions (L x W x H) During operation:	1,319-1,518x532x879-1,138 mm
Net weight	25.3-27.6 kg (55.8-60.8 lbs.)

Cordless Lawn Mower

DLM432
430 mm (17")



new

Cutting Width	430 mm (17")
Cutting Height	20-75 mm (13/16-2-15/16")
No Load Speed (RPM)	3,600
Dimensions (L x W x H)	1,490x460x1,005-1,045 mm (56-1/2-58-3/4 x 18-1/8 x 39-1/2-41-1/4")
Net weight	16.8-17.5 kg (37.0-38.6 lbs.)

Cordless Lawn Mower

DLM382
380 mm (15")



new

Cutting Width	380 mm (15")
Cutting Height	20-75 mm (13/16-2-15/16")
No Load Speed (RPM)	3,700
Dimensions (L x W x H)	1,410 x 450 x 985-1,005 mm (54-1/4-55-1/2 x 17-3/4 x 38-3/4-39-1/2")
Net weight	16.2-16.9 kg (35.7-37.3 lbs.)

DLM382PT2
DLM382Z

Electric Lawn Mower

ELM3720
370 mm (14-1/2")



new

Continuous rating input	1,400W
Hole Diameter	8 mm (5/16")
Cutting Width	370 mm (14-1/2")
Cutting Height	20-55 mm (13/16"-2-3/16")
Vibration Level	2.5 m/s ² or less
Sound Pressure Level	83 dB(A)
Sound Power Level	94 dB(A)
Dimensions (L x W x H) During operation:	1,330x415x890-1,120 mm (52-3/8"x16-3/8"x35"-44")
Net weight	11.6 kg (25.6 lbs.)

ELM3720

Electric Lawn Mower

ELM4121
410 mm (16-1/8")



Continuous rating input	1,600W
Hole Diameter	8 mm (5/16")
Cutting Width	410 mm (16-1/8")
Cutting Height	20-75 mm (13/16"-2-15/16")
Vibration Level	2.5 m/s ² or less
Sound Pressure Level	84 dB(A)
Sound Power Level	95 dB(A)
Dimensions (L x W x H) During operation:	1,465x530x905-1,135 mm (57-3/4"x20-7/8"x35-5/8"-44-3/4")
Net weight	17.5-19.1 kg (38.6-42.1 lbs.)

ELM4121

Electric Lawn Mower

ELM4621
460 mm (18-1/8") Self-Propelled (Single Speed)



Continuous rating input	1,800W
Hole Diameter	12.1 mm (1/2")
Cutting Width	460 mm (18-1/8")
Cutting Height	20-75 mm (13/16"-2-15/16")
Vibration Level	2.5 m/s ² or less
Sound Pressure Level	83 dB(A)
Sound Power Level	95 dB(A)
Dimensions (L x W x H) During operation:	1,790x570x950-1,165 mm (70-1/2"x22-1/2"x37-3/8"-45-7/8")
Net weight	30.5-32.2 kg (67.2-71.0 lbs.)

ELM4621

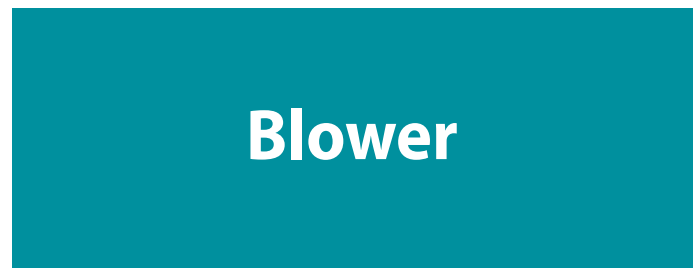

Petrol Blower

BHX2500
24.5 mL 4-stroke



Displacement	24.5 mL
Power Rating	0.81 kW
Max Air Volume	10.1 m ³ /min (356 CFM)
Max Air Velocity	65 m/s (145 MPH)
Fuel Tank Capacity	0.52 L (17.6 oz.)
Sound Pressure Level	88.7 dB(A)
Sound Power Level	102 dB(A)
Vibration Level	5.2 m/s ²
No Load Speed (RPM)	3,500-7,800
Dimensions (L x W x H)	350x231x368 mm (13.8"x9.1"x14.5")
Net weight	4.5 kg (9.8 lbs.)

Net weight: W/O Fuel, With Blower pipe, Overall length: W/O Blower pipe

Petrol Blower

EB5300TH
52.5 mL
4-stroke Tube-mounted throttle



Displacement	52.5 mL
Power Rating	1.8 kW (2.5 PS)
Max Air Volume	15 m ³ /min (516 CFM)
Max Air Velocity	98 m/s (220 MPH)
Fuel Tank Capacity	1.8 L (61 oz.)
No Load Speed (RPM)	2,800-6,400
Max Torque	3.0 N·m
Sound Pressure Level	96.0 dB(A)
Sound Power Level	102.5 dB(A)
Vibration Level Right	Long Pipe, Volume Nozzle: 2.2 m/s ²
Handle	Short Pipe, Circular Nozzle: 2.2 m/s ²
Dimensions (L x W x H)	320x450x475 mm (12-5/8"x17-3/4"x18-3/4")
Net weight	9.8-10.1 kg (21.7-22.3 lbs.)

Net weight: W/O Fuel & Blower pipe, Overall length: W/O Blower pipe

Petrol Blower

EB7660TH
75.6 mL 4-stroke Tube-mounted throttle



MM4
CDI
EB7660TH

Displacement	75.6 mL
Power Rating	3.0 kW (4.1 PS)
Max Air Volume	20 m ³ /min (706 CFM)
Max Air Velocity	92 m/s (205 MPH)
Fuel Tank Capacity	1.9 L (64 oz)
No Load Speed (RPM)	2,800 - 7,200
Max Torque	4.7 N·m
Sound Pressure Level	102.8 dB(A)
Sound Power Level	110.7 dB(A)
Vibration Level Right	Long Pipe, Circular Nozzle: 2.3 m/s ²
Handle	Long Pipe w/ Flat Nozzle: 3.4 m/s ² Short Pipe, Circular Nozzle: 2.3 m/s ² Short Pipe w/ Flat Nozzle: 3.5 m/s ²
Dimensions (L x W x H)	332x460x480 mm (13-1/8"x18-1/8"x18-7/8")
Net weight	11.9 - 12.1 kg (26.2 - 26.7 lbs.)

Net weight: W/O Fuel & Blower pipe. Overall length: W/O Blower pipe

Cordless Blower

DUB362
6-Speed Blower



36V
BL MOTOR
XPT

Max Air Volume	13.4 m ³ /min (473 CFM)
Max Air Velocity	54 m/s (120 MPH)
No Load Speed (RPM)	11,400 - 21,500
Sound Pressure Level	79.1 dB(A)
Sound Power Level	93.5 dB(A)
Vibration Level	2.5 m/s ² or less
Dimensions (L x W x H)	830/880/930x205x295 mm (32-3/4"/34-3/4"/36-5/8"x 8-1/8"x11-5/8")
Net weight	3.5 - 4.2 kg (7.7 - 9.3 lbs.)

DUB362PT4X
DUB362Z

Cordless Blower

DUB363

new
LXT
BL MOTOR
XPT



Max Air Volume	13.4 m ³ /min (473 CFM)
Max Air Velocity	65 m/s
No Load Speed (RPM)	0 - 7,850
Dimensions (L x W x H)	w/ 3-Stage Telescopic Long Nozzle: 737/786/836x200x415 mm (7-7/16"/31"/33"x7-7/8"x16-3/8")
Net weight	4.3 - 6.6 kg (9.4 - 14.6 lbs.)

DUB363PT2V
DUB363ZV

Cordless Blower

DUB184



BL MOTOR
XPT
18V

Max Air Volume	13.0 m ³ /min (459 CFM)
Max Air Velocity	52.1 m/s (116 MPH)
No Load Speed (RPM)	0 - 18,000
Sound Pressure Level	86.6 dB(A)
Sound Power Level	93.5 dB(A)
Vibration Level	2.5 m/s ² or less
Dimensions (L x W x H)	w/ BL1815N / BL1820B: 810x160x285 mm (32"x6-5/16"x11-1/4")
Net weight	2.5 - 3.0 kg (5.4 - 6.7 lbs.)

DUB184ST
DUB184Z

Cordless Blower

DUB361

36V
BL MOTOR
XPT



Max Air Volume	High: 4.4 m ³ /min (155 CFM) Low: 2.6 m ³ /min (92 CFM)
Max Air Velocity	High: 93 m/s (208 MPH) Low: 57 m/s (128 MPH)
No Load Speed (RPM)	High: 17,000 Low: 10,000
Sound Pressure Level	82.3 dB(A)
Sound Power Level	94.7 dB(A)
Vibration Level	2.5 m/s ² or less
Dimensions (L x W x H)	905x141x194 mm (35-5/8"x5-5/8"x7-5/8")
Net weight	3.1 - 3.2 kg (6.8 - 7.1 lbs.)

DUB361Z

Cordless Blower

DUB186

new
BL MOTOR
XPT
18V



Max Air Volume	3.2 m ³ /min
Max Air Velocity	68 m/s
No Load Speed (RPM)	0 - 18,000
Blowing Force	2.5 N
Run Time (min)	w/ BL1850(B), High / Mid / Low: 20 / 50 / 130
Sound Pressure Level	82.5 dB(A)
Noise K Factor	2.3 dB(A)
Sound Power Level	92.4 dB(A)
Vibration Level	Operation w/o Load: 2.5 m/s ² or less
Dimensions (L x W x H)	w/ BL1815N / BL1820B: 859 x 156 x 195 mm (33-3/4"x6-1/8"x7-5/8")
Net weight	1.6 - 2.1 kg (3.5 - 4.6 lbs.)

DUB186RT
DUB186Z

Cordless Blower

DUB183



18V

Air volume	2.6 m ³ /min
Air speed	52 m/s
No Load Speed (RPM)	0-18,000
Sound Pressure Level	85 dB(A)
Sound Power Level	95 dB(A)
Vibration Level	2.5 m/s ²
Dimensions (L x W x H)	845x155x212 mm (33-1/4"x6-1/8"x8-3/8")
Net weight	1.7 - 2.0 kg (3.8 - 4.4 lbs.)

DUB183Z

Mist Blower

PM7650H
75.6 mL 4-stroke



MM4
CDI
PM7650H - Rs. 77,700

Displacement	75.6 mL
Fuel Tank Capacity	1.8 L
Max Air Volume	14.1 m ³ /min (497 CFM)
The velocity of the wind (w/o blower pipes)	85 m/s
Sound Pressure Level	98.3 dB(A)
Sound Power Level	110.7 dB(A)
Vibration Level	3.5 m/s ²
Dimensions (L x W x H)	420x440x595 mm (16-1/2"x17-1/4"x23-1/2")
Net weight	13.9 kg (30.6 lbs.)

Net weight: without fuel with blower pipe, Overall length: Without blower pipes

Power Cutter

Petrol Power Cutter

EK8100
405 mm (16")



CDI

EK8100

Wheel Diameter	405 mm (16")
Engine	81 mL
Max cutting depth	147 mm (5-3/4")
Circumferential speed	80 m/s
Engine power	4.2 kW / 5.6 PS
Fuel Tank Capacity	1.1 L
Sound Pressure Level	100.3 dB(A)
Sound Power Level	109.6 dB(A)
Vibration Level Front Grip	7.8 m/s ²
Vibration Level Rear Grip	6.1 m/s ²
Overall Length	830 mm (32-3/4")
Net weight	10.6 kg (23.4 lbs.)

Net weight : without blade and fuel. Trolley and foot with wheels are available as option.

Petrol Power Cutter

DPC6430
300 mm (12")



CDI

DPC6430

Wheel Diameter	300 mm (12")
Engine	64 mL
Max cutting depth	97 mm (3-13/16")
Circumferential speed	80 m/s
Engine power	3.3 kW / 4.5 PS
Fuel Tank Capacity	1.1 L
No Load Speed (RPM)	4,300
Overall Length	770 mm (30-1/4")
Net weight	9.4 kg (20.7 lbs.)

Net weight : without blade and fuel. Trolley and foot with wheels are available as option.

Petrol Power Cutter

EK7651H
355 mm (14")



CDI

EK7651H

Wheel Diameter	355 mm (14")
Engine	75.6 mL
Max cutting depth	122 mm (4-13/16")
No Load Speed (RPM)	4,300
Circumferential speed	80 m/s
Engine power	3.0 kW / 4.1 PS
Fuel Tank Capacity	1.1 L
Sound Pressure Level	92.7 dB(A)
Sound Power Level	104.6 dB(A)
Vibration Level Front Grip	2.7 m/s ²
Vibration Level Rear Grip	1.8 m/s ²
Dimensions (L x W x H)	780x310x455 mm (30-3/4"x12-1/4"x17-7/8")
Net weight	14.2 kg (31.3 lbs.)

Net weight : without blade and fuel. Trolley and foot with wheels are available as option.

Power Cutter

EK6101
355 mm (14")



Wheel Diameter	355 mm (14")
Engine	61 mL
Max cutting depth	130 mm (5-1/8")
No Load Speed (RPM)	4,400
Circumferential speed	80 m/s
Engine power	3.2 kW / 4.4 PS
Fuel Tank Capacity	0.7 L
Sound Pressure Level	100 dB(A)
Sound Power Level	109 dB(A)
Vibration Level Front Grip	2.7 m/s ²
Vibration Level Rear Grip	3.5 m/s ²
Overall Length	730 mm (28-3/4")
Net weight	8.8 kg (19.4 lbs.)



Net weight : without blade and fuel. Trolley and foot with wheels are available as option.

Petrol Power Cutter

EK7301
355 mm (14")



Wheel Diameter	355 mm (14")
Engine	73 mL
Max cutting depth	122 mm (4-13/16")
Engine power	3.8 kW / 5.1 PS
Fuel Tank Capacity	1.1 L
Sound Pressure Level	99.6 dB(A)
Sound Power Level	109 dB(A)
Vibration Level Front Grip	7.0 m/s ²
Vibration Level Rear Grip	4.9 m/s ²
Dimensions (L x W x H)	770x290x370 mm (30-1/4"x11-3/8"x14-1/2")
Net weight	10.1 kg (22.3 lbs.)



Net weight : without blade and fuel. Trolley and foot with wheels are available as option.

High Pressure Washer

High Pressure Washer

HW102



Continuous rating input	1,300W
Max Pressure	10 MPa (100 bar, 1,450 PSI)
Max Flow Rate	360 L/h
Motor type	Universal
Max Feed Temperature	50 °C (122 °F)
High Pressure Hose Length	5 m (16.4 ft.)
Sound Pressure Level	85.74 dB(A)
Sound Power Level	94 dB(A)
Vibration Level	3.72 m/s ²
Net weight	5.8 kg (12.8 lbs.)

HW102

High Pressure Washer

HW111



Continuous rating input	1,700W
Max Pressure	11 MPa (110 bar, 1,595 PSI)
Max Flow Rate	370 L/h
Motor type	Universal
Max Feed Temperature	50 °C (122 °F)
High Pressure Hose Length	5.5 m (18 ft.)
Sound Pressure Level	79.15 dB(A)
Sound Power Level	87 dB(A)
Vibration Level	3.72 m/s ²
Net weight	7.4 kg (16.3 lbs.)

HW111

High Pressure Washer

HW1200



Continuous rating input	1,800W
Max Pressure	12 MPa (120 bar, 1,740 PSI)
Max Flow Rate	420 L/h
Max Feed Temperature	40 °C (104 °F)
High Pressure Hose Length	10 m (33 ft.)
Sound Pressure Level	72 dB(A)
Vibration Level	4.11 m/s ²
Dimensions (L x W x H)	292x358x830 mm (11-1/2"x14-1/8"x32-3/4")
Net weight	11 kg (24.3 lbs.)
Power supply cord	5.0 m (16.4 ft.)

HW1200

High Pressure Washer

HW1300



Continuous rating input	1,800W
Max Pressure	13 MPa (130 bar, 1,885 PSI)
Max Flow Rate	450 L/h
Max Feed Temperature	40 °C (104 °F)
High Pressure Hose Length	10 m (33 ft.)
Sound Pressure Level	76 dB(A)
Vibration Level	4.86 m/s ²
Dimensions (L x W x H)	292x358x830 mm (11-1/2"x14-1/8"x32-3/4")
Net weight	12.7 kg (28 lbs.)
Power supply cord	5.0 m (16.4 ft.)

HW1300

High Pressure Washer

HW112



Continuous rating input	1,600W
Max Pressure	12 MPa (120 bar, 1,740 PSI)
Max Flow Rate	370 L/h
Motor type	Induction
Max Feed Temperature	50 °C (122 °F)
High Pressure Hose Length	5.5 m (18 ft.)
Sound Pressure Level	78.4 dB(A)
Sound Power Level	86 dB(A)
Vibration Level	3.41 m/s ²
Net weight	16.2 kg (35.7 lbs.)

HW112

Hot Water Power Washer

HW120



Continuous rating input	2,200W
Max Pressure	12 MPa (120 bar, 1,740 PSI)
Max Flow Rate	510 L/hr
Fuel Tank Capacity	8 L
Diesel burner	30-90 °C
High Pressure Hose Length	8 m (26.3 ft.)
Length	
Net weight	78.7 kg (173.5 lbs.)

HW120

High Pressure Washer

HW121



Continuous rating input	2,100W
Max Pressure	13 MPa (130 bar, 1,885 PSI)
Max Flow Rate	390 L/h
Motor type	Induction
Max Feed Temperature	50 °C (122 °F)
High Pressure Hose Length	8 m (26.3 ft.)
Sound Pressure Level	77.33 dB(A)
Sound Power Level	85 dB(A)
Vibration Level	3.72 m/s ²
Net weight	17.8 kg (39.2 lbs.)

HW121

High Pressure Washer

HW132



Continuous rating input	2,100W
Max Pressure	14 MPa (140 bar, 2,030 PSI)
Max Flow Rate	390 L/h
Motor type	Induction
Max Feed Temperature	50 °C (122 °F)
High Pressure Hose Length	8 m (26.3 ft.)
Sound Pressure Level	77.33 dB(A)
Sound Power Level	85 dB(A)
Vibration Level	3.72 m/s ²
Net weight	18.8 kg (41.4 lbs.)

HW132

High Pressure Washer

HW131



Continuous rating input	2,300W
Max Pressure	3 MPa (130 bar, 1,885 PSI)
Max Flow Rate	500 L/h
Motor type	Induction
Max Feed Temperature	50 °C (122 °F)
High Pressure Hose Length	8 m (26.3 ft.)
Sound Pressure Level	77.33 dB(A)
Sound Power Level	85 dB(A)
Vibration Level	3.72 m/s ²
Net weight	33 kg (72.8 lbs.)

HW131

High Pressure Washer

DHW080



Max Permissible Pressure	8.0 MPa (N/A bars)
Regular Pressure	High / Low: 5.5 / 3.0 MPa (N/A / N/A bars)
Max Water Flow	380 L/h (6.3 L/min)
Regular Flow	High/Low: 330 / 240 L/h (5.5 / 4.0 L/min)
High Pressure Hose Length	5 m (16 ft.)
Vibration Level	2.5 m/s ² or less
Sound Pressure Level	70.9 dB(A)
Dimensions (L x W x H)	438x218x269 mm (17-1/4"x8-5/8"x10-5/8")
Net weight	7.1 - 7.7 kg (15.6 - 17.0 lbs.)

**DHW080PT2
DHW080ZK**

High Pressure Washer

HW140



Continuous rating input	2,300W
Max Pressure	14 MPa (140 bar, 2,030 PSI)
Max Flow Rate	500 L/h
Motor type	Induction
Max Feed Temperature	50 °C (122 °F)
High Pressure Hose Length	10 m (33 ft.)
Sound Pressure Level	82.68 dB(A)
Sound Power Level	91 dB(A)
Vibration Level	4.83 m/s ²
Net weight	29.0 kg (63.9 lbs.)

HW140

High Pressure Washer

HW151



Continuous rating input	2,500W
Max Pressure	15 MPa (150 bar, 2,175 PSI)
Max Flow Rate	500 L/h
Motor type	Induction
Max Feed Temperature	50 °C (122 °F)
High Pressure Hose Length	10 m (33 ft.)
Sound Pressure Level	80.1 dB(A)
Sound Power Level	88 dB(A)
Vibration Level	2.74 m/s ²
Net weight	26.9 kg (59.3 lbs.)

HW151

Sprayer

Sprayer

EVH2000

24.5 mL 4-stroke

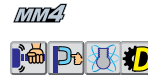

Displacement	24.5 mL
Fuel Tank Capacity	0.5 L
Max Pressure	2.5 MPa (25 kgf/cm ²)
Chemical tank	20 L
Dimensions (L x W x H)	380x420x635 mm (15"x16-1/2"x25")
Net weight	9.1 kg (20.1 lbs.)

EVH2000

Net weight: without fuel

Cordless Garden Sprayer

DVF104
10 L



Max Pressure	0.3 MPa (3 kgf/cm ²)
Chemical tank	10 L
Dimensions (L x W x H)	315x225x415 mm (12-3/8"x8-7/8"x16-3/8")
Net weight	3.8 - 4.1 kg (8.4 - 9.1 lbs.)

DVF104Z

18V

Cordless Garden Sprayer

DVF154
15L



Max Pressure	0.3 MPa (3 kgf/cm ²)
Chemical tank	15 L
Dimensions (L x W x H)	345x235x525 mm (13-5/8"x9-1/4"x20-3/4")
Net weight	4.1 - 4.4 kg (9.1 - 9.7 lbs.)

DVF154Z

18V



Others

Petrol Earth Auger

BBA520



Displacement	51.7 cm ³
Power rating	2.7 PS
	1.98 kW
Fuel tank capacity	0.9 l
Sound pressure level	93 dB(A)
Vibration acceleration	1.10 m/s ²
Drilling depth w/ extension	120 cm
Drilling depth w/o extension	80 cm
Net weight	10.5 kg

BBA520

Makita®

ent



2021

Drilling / Fastening

High Speed Drill

M6501B
6.5mm (1/4")



85 mm

Continuous rating input	230W
Capacity	Steel: 6.5 mm (1/4") Wood: 9 mm (11/32")
No Load Speed (RPM)	0 - 4,500
Vibration Level	Drilling Into Metal: 3.0 m/s ²
Sound Pressure Level	70 dB(A)
Dimensions (L x W x H)	203x63x171 mm (8"x2-1/2"x6-3/4")
Net weight	0.95 kg (2.1 lbs)
Power supply cord	2.0 m (6.6 ft.)

M6501B

Drill

M6200B
13mm (1/2")



303 mm

Continuous rating input	800W
Capacity	Steel: 13 mm (1/2") Wood: 36 mm (1-7/16")
No Load Speed (RPM)	0 - 700
Vibration Level	Drilling Into Metal: 2.5 m/s ² or less
Sound Pressure Level	84 dB(A)
Sound Power Level	95 dB(A)
Dimensions (L x W x H)	267x86x388 mm (10-1/2"x3-3/8"x15-1/4")
Net weight	2.7 kg (6.0 lbs)
Power supply cord	2.0 m (6.6 ft.)

M6200B

Drill

M0600B



64 mm

Continuous rating input	350W
Capacity	Steel: 10 mm (3/8") Wood: 20 mm (13/16")
No Load Speed (RPM)	0 - 3,000
Vibration Level	Drilling Into Metal: 3.0 m/s ²
Sound Pressure Level	77 dB(A)
Dimensions (L x W x H)	230x66x176 mm (9"x2-5/8"x6-15/16")
Net weight	1.2 kg (2.6 lbs)
Power supply cord	2.0 m (6.6 ft.)

M0600B

Drill

M6202XB
13mm (1/2")



64 mm

Continuous rating input	580W
Capacity	Steel: 13 mm (1/2") Wood: 25 mm (1")
No Load Speed (RPM)	2,000
Dimensions (L x W x H)	239x69x178 mm (9-3/8"x2-3/4"x7")
Net weight	1.7 kg (3.7 lbs.)
Power supply cord	2.0 m (6.6 ft.)

M6202XB

Mixer

M6600B



303 mm

Continuous rating input	800W
Blade Diameter	165 mm (6-1/2")
No Load Speed (RPM)	0 - 700
Vibration Level	2.5 m/s ² or less
Sound Pressure Level	85 dB(A)
Sound Power Level	96 dB(A)
Dimensions (L x W x H)	280x86x388 mm (11"x3-3/8"x15-1/4")
Net weight	2.6 - 2.7 kg (5.7 - 5.9 lbs)
Power supply cord	2.0 m (6.6 ft.)

M6600B

Impact Drilling

Rotary Hammer

M8700B



459 mm

Continuous rating input	710W
Impact Energy	EPTA-Procedure 05/2009: 1.9 J
Capacity	Concrete: 22 mm (7/8") Core Bit: 54 mm (2-1/8") Diamond Core Bit (Dry Type): 65 mm Steel: 13 mm Wood: 32 mm
Blows Per Minute (BPM)	0 - 4,350
No Load Speed (RPM)	0 - 1,100
Vibration Level	Hammer Drilling Into Concrete: 15.5 m/s ²
Sound Pressure Level	90 dB(A)
Sound Power Level	101 dB(A)
Dimensions (L x W x H)	362x71x194 mm
Net weight	2.5 - 2.9 kg (5.6 - 6.4 lbs)
Power supply cord	4.0 m (13.1 ft.)

M8700B

Hammer Drill

M0801B
16mm(5/8")



85 mm

Continuous rating input	500W
Capacity	Concrete: 16 mm (5/8") Steel: 13 mm (1/2") Wood: 20 mm (13/16")
Blows Per Minute (BPM)	0 - 48,000
No Load Speed (RPM)	0 - 3,200
Vibration Level	Hammer Drilling Into Concrete: 14.5 m/s ²
Sound Pressure Level	Drilling Into Metal: 4.0 m/s ²
Sound Power Level	94 dB(A)
Dimensions (L x W x H)	261x69x195 mm (10-1/4"x2-3/4"x7-5/8")
Net weight	1.7 kg (3.7 lbs)
Power supply cord	2.0 m (6.6 ft.)

M0801B

Combination Hammer

M8701B
26 mm (1")



325 mm

Continuous rating input	800W
Impact Energy	EPTA-Procedure 05/2009: 2.3 J
Capacity	Concrete: 26 mm (1") Core Bit: 68 mm (2-11/16") Diamond Core Bit (Dry Type): 80 mm (3-1/8") Steel: 13 mm (1/2") Wood: 32 mm (1-1/4")
No Load Speed (RPM)	0 - 1,200
Blows Per Minute (BPM)	0 - 4,500
Sound Pressure Level	90 dB(A)
Sound Power Level	101 dB(A)
Dimensions (L x W x H)	362x71x194 mm
Net weight	2.7 kg (6.0 lbs)
Power supply cord	4.0 m (13.1 ft.)

M8701B

Demolition Hammer

M8600B



105 mm

Continuous rating input	900W
Impact Energy	7.2 J
Blows Per Minute (BPM)	2,900
Vibration Level	Chiselling Funtion w/ Side Grip: 16.5 m/s ²
Sound Pressure Level	95 dB(A)
Sound Power Level	106 dB(A)
Dimensions (L x W x H)	406x99x232 mm (16"x3-7/8"x9-1/8")
Net weight	5.4 kg (12 lbs)
Power supply cord	2.5 m (8.2 ft.)

M8600B



Cutting

Portable Cut-Off

M2402
355 mm (14")



203

Continuous rating input	2,200W
Wheel Diameter	355 mm (14")
No Load Speed (RPM)	3,900
Vibration Level	4.5 m/s ²
Sound Pressure Level	98 dB(A)
Sound Power Level	108 dB(A)
Dimensions (L x W x H)	500 x 280 x 630 mm (19-3/4 x 11 x 24-3/4")
Net weight	14.0 - 15.5 kg (30.9 - 34.2 lbs.)
Power supply cord	2.5 m (8.2 ft.)

M2402B

Portable Cut-Off

M2401B
355 mm (14")



203

Continuous rating input	2,000W
Wheel Diameter	355 mm (14")
No Load Speed (RPM)	3,800
Vibration Level	3.0 m/s ²
Sound Pressure Level	100 dB(A)
Sound Power Level	111 dB(A)
Dimensions (L x W x H)	500x280x620 mm (19-3/4"x11"x24-3/8")
Net weight	13.7 kg (30.2 lbs.)
Power supply cord	2.5 m (8.2 ft.)

M2401B

Portable Cut-Off

M2403
355 mm (14")



203

Continuous rating input	2,200W
Wheel Diameter	355 mm (14")
No Load Speed (RPM)	3,900
Vibration Level	3.5 m/s ²
Sound Pressure Level	99 dB(A)
Sound Power Level	109 dB(A)
Dimensions (L x W x H)	515 x 280 x 640 mm (20-1/4 x 11 x 25-1/4")
Net weight	13.8 - 15.3 kg (30.4 - 33.7 lbs.)
Power supply cord	2.5 m (8.2 ft.)

M2403B

Cutter

M4100B
110 mm (4-3/8")



303

Continuous rating input	1,200W
Blade Diameter	110 mm (4-3/8")
Max Cutting Capacity	90°: 32 mm (1-1/4")
No Load Speed (RPM)	13,000
Vibration Level	Concrete Cutting: 5.5 m/s ²
Sound Pressure Level	100 dB(A)
Sound Power Level	111 dB(A)
Dimensions (L x W x H)	227x209x166 mm (8-15/16x8-1/4x6-1/2")
Net weight	2.9 kg (6.4 lbs.)
Power supply cord	2.0 m (6.6 ft.)

M4100B

Cutter

M0401B
110 mm (4-3/8")



203

Continuous rating input	1,200W
Blade Diameter	110 mm (4-3/8")
Max Cutting Capacity	90°: 32.0 mm (1-1/4")
No Load Speed (RPM)	13,800
Vibration Level	Concrete Cutting: N/A m/s ²
Dimensions (L x W x H)	231x195x164 mm (9-1/8"x7-5/8"x6-1/2")
Net weight	2.6 kg (5.7 lbs.)
Power supply cord	2.0 m (6.6 ft.)

M0401B

Cutter

M4101B
125 mm (5")



303

Continuous rating input	1,250W
Blade Diameter	125 mm (5")
Max Cutting Capacity	90°: 40 mm (1-9/16")
No Load Speed (RPM)	12,000
Vibration Level	Concrete Cutting: 5.0 m/s ²
Sound Pressure Level	98 dB(A)
Sound Power Level	109 dB(A)
Dimensions (L x W x H)	233x216x166 mm (9-1/8"x8-1/2"x6-1/2")
Net weight	3.0 kg (6.7 lbs.)
Power supply cord	2.0 m (6.6 ft.)

M4101B

Grinding

Angle Grinder

M0900B
100 mm (4")



459

Continuous rating input	540W
Wheel Diameter	100 mm (4")
No Load Speed (RPM)	12,000
Dimensions (L x W x H)	251x118x97 mm (9-7/8"x4-5/8"x3-13/16")
Net weight	1.6 kg (3.5 lbs.)
Power supply cord	2.0 m (6.6 ft.)

M0900B

Tool does not come with depressed center wheel.

Angle Grinder

M9506B
100 mm (4")



459

Continuous rating input	720W
Wheel Diameter	100 mm (4")
No Load Speed (RPM)	11,000
Vibration Level	Surface Grinding: 6.5 m/s ²
Sound Pressure Level	86 dB(A)
Sound Power Level	97 dB(A)
Dimensions (L x W x H)	261x118x101 mm (10-1/4"x4-5/8"x4")
Net weight	1.6 kg (3.6 lbs.)
Power supply cord	2.0 m (6.6 ft.)

M9506B

Angle Grinder

M0910B
100 mm (4")



459

Continuous rating input	540W
Wheel Diameter	100 mm (4")
No Load Speed (RPM)	12,000
Dimensions (L x W x H)	251x118x93 mm (9-7/8"x4-5/8"x3-5/8")
Net weight	1.6 kg (3.4 lbs.)
Power supply cord	2.0 m (6.6 ft.)

M0910B

Tool does not come with depressed center wheel.

Angle Grinder

M9509B
100 mm (4")



325

Continuous rating input	850W
Wheel Diameter	100 mm (4")
No Load Speed (RPM)	11,000
Vibration Level	Surface Grinding: 6.5 m/s ²
Sound Pressure Level	87 dB(A)
Sound Power Level	98 dB(A)
Dimensions (L x W x H)	276x118x101 mm (10-7/8"x4-5/8"x4")
Net weight	1.8 kg (3.9 lbs.)
Power supply cord	2.0 m (6.6 ft.)

M9509B

Tool does not come with depressed center wheel.

Angle Grinder

M9512B
100mm (4")

459

Continuous rating input	720W
Wheel Diameter	100 mm (4")
No Load Speed (RPM)	11,000
Dimensions	258x118x101 mm (L x W x H) (10-1/8"x4-5/8"x4")
Net weight	1.6 kg (3.5 lbs.)
Power supply cord	2.0 m (6.6 ft.)



M9512B

Angle Grinder

M9513B
100mm (4")

325

Continuous rating input	850W
Wheel Diameter	100 mm (4")
No Load Speed (RPM)	11,000
Dimensions	273x118x101 mm (L x W x H) (10-3/4"x4-5/8"x4")
Net weight	1.8 kg (4.0 lbs.)
Power supply cord	2.0 m (6.6 ft.)



M9513B

Angle Grinder

M9002B
125mm (5")

153

Continuous rating input	1,050W
Wheel Diameter	125 mm (5")
No Load Speed (RPM)	11,000
Vibration Level	Surface Grinding: 9.0 m/s ²
Sound Pressure Level	91 dB(A)
Sound Power Level	102 dB(A)
Dimensions	361x140x124 mm (L x W x H) (14-1/4"x5-1/2"x4-7/8")
Net weight	2.8 kg (6.1 lbs.)
Power supply cord	2.0 m (6.6 ft.)



M9002B

Angle Grinder

M9508B
125mm (5")

459

Continuous rating input	720W
Wheel Diameter	125 mm (5")
No Load Speed (RPM)	11,000
Vibration Level	Surface Grinding: 7.0 m/s ²
Sound Pressure Level	88 dB(A)
Sound Power Level	99 dB(A)
Dimensions	261x140x111 mm (L x W x H) (10-1/4"x5-1/2"x4-3/8")
Net weight	1.9 kg (4.1 lbs.)
Power supply cord	2.0 m (6.6 ft.)



M9508B

Angle Grinder

M9511B
125 mm (5")

325

Continuous rating input	850W
Wheel Diameter	125 mm (5")
No Load Speed (RPM)	11,000
Vibration Level	Surface Grinding: 9.0 m/s ²
Sound Pressure Level	89 dB(A)
Sound Power Level	100 dB(A)
Dimensions	276x140x111 mm (L x W x H) (10-7/8"x5-1/2"x4-3/8")
Net weight	2.0 kg (4.5 lbs.)
Power supply cord	2.0 m (6.6 ft.)



M9511B

Angle Grinder

M0921B / M0920B
230mm (9") / 180mm (7")

203

Continuous rating input	2,200W
Wheel Diameter	M0921B: 230 mm (9") M0920B: 180 mm (7")
No Load Speed (RPM)	M0921B: 6,600 M0920B: 8,500
Sound Power Level	102 dB(A)
Dimensions (L x W x H)	M0921B: 439x250x141 mm (17-1/4"x9-7/8"x5-9/16") M0920B: 439x200x141 mm (17-1/4"x7-7/8"x5-9/16")
Net weight	M0921B: 5.3 kg (11.6 lbs.) M0920B: 5.0 kg (11.0 lbs.)
Power supply cord	2.0 m (6.6 ft.)



M0921B
M0920B

Multi Tool

M9800B

459

Continuous rating input	200W
Strokes Per Minute (SPM)	6,000-20,000
Vibration Level	Cutting w/ Plunge Cut Saw Blade: 8.0 m/s ²
Sound Pressure Level	Sanding: 78 dB(A)
Dimensions (L x W x H)	283x68x98 mm (11-1/8"x2-11/16"x3-7/8")
Net weight	1.2 - 1.3 kg (2.7 - 3.0 lbs.)
Power supply cord	2.0 m (6.6 ft.)



new



M9800BKX2

Die Grinder

M9100B
6mm (1/4")

411

Continuous rating input	480W
Capacity	Collet: 6 mm or 1/4"
Max Wheel Diameter	20 mm (13/16")
No Load Speed (RPM)	33,000
Vibration Level	Surface Grinding: 2.5 m/s ²
Dimensions (L x W x H)	350x75x75 mm (13-3/4"x2-15/16"x2-15/16")
Net weight	1.4 kg (3.1 lbs.)
Power supply cord	2.0 m (6.6 ft.)



M9100B

Finishing Sander

M9200B

419

Continuous rating input	180W
Pad Size	112 x 102 mm (4-3/8" x 4")
Abrasive Paper Size	114 x 140 mm (4-1/2" x 5-1/2")
Orbits Per Minute (OPM)	14,000
Vibration Level	Sanding Metal Plate: 4.5 m/s ²
Sound Pressure Level	79 dB(A)
Dimensions (L x W x H)	110x112x133 mm (4-5/16"x4-3/8"x5-1/4")
Net weight	0.9 kg (2 lbs.)
Power supply cord	2.0 m (6.6 ft.)



M9200B

Finishing Sander

M9201B

64

Continuous rating input	180W
Pad Size	93 x 185 mm (3-5/8" x 7-1/4")
Abrasive Paper Size	93 x 228 mm (3-5/8" x 9")
Orbits Per Minute (OPM)	12,000
Vibration Level	Sanding Metal Plate: 6 m/s ²
Sound Pressure Level	74 dB(A)
Dimensions (L x W x H)	214x92x147 mm (8-3/8"x3-5/8"x5-3/4")
Net weight	1.4 kg (3.1 lbs.)
Power supply cord	2.0 m (6.6 ft.)



M9201B

Random Orbit Sander

M9202B
125mm (5")

Continuous rating input	240W
Pad Size	123 mm (4-7/8")
Abrasive Disc Size	125 mm (5")
Orbits Per Minute (OPM)	12,000
Strokes Per Minute (SPM)	24,000
Orbit Diameter	2.8 mm (1/8")
Dimensions (L x W x H)	127x123x142 mm (5"x4-7/8"x5-5/8")
Net weight	1.1 kg (2.4 lbs.)
Power supply cord	2.0 m (6.6 ft.)



M9202B

Belt Sander

M9400B
100mm (4")

153

Continuous rating input	940W
Belt Size	100 x 610 mm (4" x 24")
Belt Speed	380 m/min (1,250 ft/min)
Vibration Level	Sanding Metal Plate: 2.5 m/s ² or less
Sound Pressure Level	87 dB(A)
Sound Power Level	98 dB(A)
Dimensions (L x W x H)	354x175x169 mm (14"x6-7/8"x6-5/8")
Net weight	6.2 kg (13.7 lbs.)
Power supply cord	2.0 m (6.6 ft.)



M9400B

Sawing

Jig Saw

M4302B



411

Continuous rating input	450W
Max Cutting Capacity at Wood: 55 mm (2-3/16")	
90°	Steel: 6 mm (1/4")
	26 mm (1")
Length of Stroke	0 - 3,100
Strokes Per Minute (SPM) Cutting Boards: 6.5 m/s ²	
Vibration Level	Cutting Sheet Metal: 7.5 m/s ²
Sound Pressure Level	88 dB(A)
Sound Power Level	99 dB(A)
Dimensions	219x85x191 mm
(L x W x H)	(8-5/8"x3-3/8"x7-1/2")
Net weight	2.5 kg (5.5 lbs.)
Power supply cord	2.0 m (6.6 ft.)

M4302B



Recipro Saw

M4500KB
125 mm (5")



303

Continuous rating input	1,010W
Length of Stroke	28 mm (1-1/8")
Strokes Per Minute (SPM) 0 - 2,800	
Capacity	Pipe : 130 mm (5-1/8")
	Wood: 255 mm (10")
Vibration Level	Cutting Boards: 19.5 m/s ²
	Cutting Wooden Beams: 22.0 m/s ²
Sound Pressure Level	88 dB(A)
Sound Power Level	99 dB(A)
Dimensions (L x W x H)	457x98x174 mm
	(18"x3-7/8"x6-7/8")
Net weight	3.1 kg (6.9 lbs.)
Power supply cord	2.0 m (6.6 ft.)

M4500KB



Power Planer

M1902B
82mm (3-1/4")



411

Continuous rating input	500W
Planing Width	82 mm (3-1/4")
Planing Depth	1 mm (1/32")
Max ShipLapping	9 mm (11/32")
No Load Speed (RPM)	16,000
Vibration Level	Planing Softwood: 3.0 m/s ²
Sound Pressure Level	84 dB(A)
Sound Power Level	95 dB(A)
Dimensions	285x157x160 mm
(L x W x H)	(11-1/4"x6-3/16"x6-5/16")
Net weight	2.7 kg (5.8 lbs.)
Power supply cord	2.0 m (6.6 ft.)

M1902B

Shiplapping: 9mm (11/32")



Router (Plunge Type)

M3601B
8mm (3/8")



64

Continuous rating input	900W
Collet Capacity	6 mm, 8 mm or 1/4", 3/8"
Plunge Capacity	0 - 35 mm (0 - 1-3/8")
No Load Speed (RPM)	27,000
Vibration Level	Cutting Grooves in MDF: 7.5 m/s ²
Sound Pressure Level	91 dB(A)
Sound Power Level	102 dB(A)
Dimensions	256x110x218 mm
(L x W x H)	(10-1/8"x4-5/16"x8-5/8")
Net weight	2.7 kg (6.0 lbs.)
Power supply cord	2.0 m (6.6 ft.)

M3601B



Circular Saw

M5801B



303

Continuous rating input	1,050W
Blade Diameter	185 mm (7-1/4")
Max Cutting Capacity	90°: 66 mm (2-5/8")
	45°: 44 mm (1-3/4")
No Load Speed (RPM)	4,900
Vibration Level	Cutting Wood: 2.5 m/s ²
Dimensions	284x231x243 mm
(L x W x H)	(11-1/8"x9-1/8"x9-9/16")
Net weight	3.5 kg (7.7 lbs.)
Power supply cord	2.0 m (6.6 ft.)

M5801B



Jig Saw

M4301B



64

Continuous rating input	450W
Max Cutting Capacity at Wood: 65 mm (2-9/16")	
90°	Steel: 6 mm (1/4")
	18 mm (11/16")
Length of Stroke	0 - 3,100
Strokes Per Minute (SPM) Cutting Wood: 8.0 m/s ²	
Vibration Level	Cutting Sheet Metal: 5.0 m/s ²
Sound Pressure Level	82 dB(A)
Sound Power Level	93 dB(A)
Dimensions	214x75x202 mm
(L x W x H)	(8-3/8"x2-15/16"x8")
Net weight	1.9 kg (4.1 lbs.)
Power supply cord	2.0 m (6.6 ft.)

M4301B



Planing / Routering

Trimmer

M3700B
6mm (1/4")



411

Continuous rating input	530W
Collet Capacity	6 mm or 1/4"
No Load Speed (RPM)	35,000
Plunge Capacity	0 - 42 mm (0 - 1-5/8")
Vibration Level	Rotation w/o Load: 2.5 m/s ² or less
Sound Pressure Level	83 dB(A)
Sound Power Level	94 dB(A)
Dimensions	82x90x199 mm
(L x W x H)	(3-1/4"x3-1/2"x7-7/8")
Net weight	1.4 kg (3.1 lbs.)
Power supply cord	2.0 m (6.6 ft.)

M3700B



Router

M3600B
12mm (1/2")



211

Continuous rating input	1,650W
Collet Capacity	12 mm or 1/2"
Plunge Capacity	0 - 60 mm (0 - 2-3/8")
No Load Speed (RPM)	22,000
Vibration Level	Cutting Grooves in MDF: 2.5 m/s ²
Sound Pressure Level	86 dB(A)
Sound Power Level	97 dB(A)
Dimensions	284x148x300 mm
(L x W x H)	(11-1/8"x5-7/8"x11-3/4")
Net weight	5.5 kg (12.2 lbs.)
Power supply cord	2.0 m (6.6 ft.)

M3600B



Straight Guide, Guide Holder Assembly, Collet Sleeve (6 mm or 1/4"), Collet Sleeve (8 mm or 3/8"), Straight Bit, Wrench, Templet Guide 16, Trimmer Guide Assembly, Dust Nozzle

Blower

M4000B
100mm (4")



85

Continuous rating input	530W
Air volume	1.2-2.9 m ³ /min
No Load Speed (RPM)	8,500 - 16,000
Vibration Level	Operation w/o Load: 2.5 m/s ² or less
Sound Pressure Level	90 dB(A)
Sound Power Level	101 dB(A)
Dimensions	427x161x212 mm
(L x W x H)	(16-3/4"x6-3/8"x8-3/8")
Net weight	1.5 kg (3.4 lbs.)
Power supply cord	2.0 m (6.6 ft.)

M4000B



Dust Extraction

Carbon brush

*These brushes make commutator smooth to reduce sparks, letting the brake system work well. Let the motor run for 10 minutes at half of the rated voltage.

** Cut-off type carbon brush



Marking No. on carbon brush	Carbon brush for Repair 110-127V Models		Carbon brush for Repair 220 240V Models		Models
	Part No.	Marking	Part No.	Marking	
CB-411	191940-4	411	B-80391	CB-411A	3709, 9031, KP0800, RT0700C, TD1011, TW0200, TW0350, 6922NB, M1901B, M1902, M3700, M4302, M9100, MT190, MT372, MT430, MT910,
CB-459**	194722-3	**459	-	-	GA4030, GA4030R, GA4031, GA4032, GA4033, GA4034, GA4530, GA4530R, GA4534, GA5030, GA5030R, GA5034, HR1840, HR1841F, JS1000, JS1601, JS1602, PJ7000, TM3000C, TM3010C, M9506B, M9508B, M9512B
-	EE7332022S	-	-	-	DBM130, DBM131, DBM230, UT1600
-	EE7132A22S	-	-	-	DBM080, UT1400, UT1401
-	EE7701822S	-	-	-	UT1200
-	UD0EIB106C	-	-	-	HB500
-	JM23000123	-	-	-	LH1200FL, LH1201FL, LS1017L, LS1018L, MLS100
-	D652023960	-	-	-	UV3200
-	D652024748	-	-	-	UV3600
-	YA00000504	-	-	-	UR3500, UR3501,
CB-154	181047-4	-	-	-	UC4550A

Grease vessel Set



Size	Part No.
500G	042040-2A
2.5 KG	042017-7A
30G	042040-2A

4-stroke engine oil



Size	Part No.
600ml	980.508.620

High-performance two-stroke engine oil 50:1

Makita High-performance two-stroke engine oil is semi-synthetic oil with excellent lubricating qualities, low smoke and low carbon residue. Contains

*with measuring cup



Size	Part No.
100ml	980.008.606
1L	980.008.607
5L	980.008.618