

THE SPIRITS BUSINESS

THE ONLY INTERNATIONAL TRADE
MEDIA SOLELY DEDICATED TO SPIRITS



MEDIA PACK 2025



A NOTE FROM THE **EDITOR**

As the world's only international trade publication dedicated to spirits, *The Spirits Business* takes pride in bringing you nothing but the highest-quality journalism



January can be called a 'quiet' month in the spirits industry – but I beg to differ. Last year, post-Christmas and new year celebrations, the industry went full pelt into new launches, marketing campaigns and events. And it didn't stop. Not for a moment. Just take a look at the prolific news coverage delivered by *The Spirits Business* over the past 12 months for proof.

From investments, mergers and acquisitions to exclusive interviews, in-depth category analysis, data and industry trends, *The Spirits Business* remains unrivalled in keeping the trade informed with need-to-know news.

We're proud to be the world's only global trade publication dedicated to spirits, and we're confident in our ability to continuously be at the forefront of the latest breaking news. Our team of award-winning journalists will always go straight to the source, ensuring the most reliable spirits updates from around the world.

There are several ways to keep up to date with industry trends and developments: our monthly print magazine, www.thespiritsbusiness.com, our daily global newsletter, our US-focused newsletter, and our app. In 2025, our readers can expect further deep dives into individual spirits categories and regions, in addition to insightful features and stories about the on-trade, which are covered in the Back Bar section of the magazine.

Furthermore, we offer a number of in-depth reports throughout the year to give additional insights to the trade. These include the *Global Travel Retail Report*, *World Spirits Report*, and *Global Bar Report*. Most notably, our *Brand Champions* supplement, compiled in-house by *The Spirits Business* editorial team, offers extensive analysis about the world's million-case-selling spirits brands. Plus, we offer compelling interviews on *The Spirits Business Podcast*.

In addition, our experienced events team strives to reward the best spirits on the market through The Global Spirits Masters Competitions, a blind-tasting series judged by independent tasters – unique in the industry.

I'm proud to chair The Global Spirits Masters Competitions – and to lead our brilliant editorial team at *The Spirits Business*. We are unwavering in our passion for the industry, and dedicated to providing the most interesting and useful articles for the global trade. We are ready and excited to work alongside our media partners to help you reach your goals in 2025.

MELITA KIELY

Editor-in-Chief

The Spirits Business



PRINT READERSHIP & CIRCULATION

The Spirits Business is the only international trade magazine and website in the world that is dedicated to spirits. The circulation of both print and digital copies is up to 13,000 copies per month across 120 countries, reaching more than 50,000 spirits professionals worldwide.

Readership

Our global audience comprises the biggest retailers, distributors, wholesalers and duty free buyers in the business. Furthermore, *The Spirits Business* reaches thousands of world-class bartenders and bar owners around the globe.

Bonus distribution

In addition to our regular subscribers, we are also distributed at all the major trade shows and events:

- ProWein, Düsseldorf
- WSWA Access Live
- IAADFS Duty Free & Travel Retail Summit of the Americas
- TFWA Asia Pacific Exhibition & Conference
- Wine Paris
- Tales of the Cocktail
- BCB Brooklyn, BCB Berlin, BCB London
- TFWA World Exhibition & Conference, Cannes
- London Cocktail Week

Readership

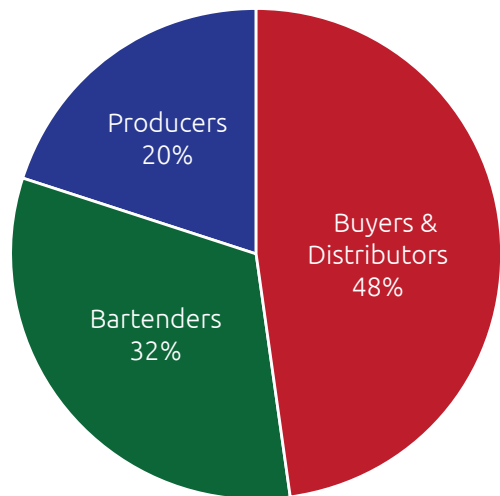

Top 15 countries

UK	Spain	Hong Kong
Germany	Ireland	Belgium
France	Canada	Finland
US	Portugal	Russia
Italy	Bulgaria	Mexico

Union Press, Fourth Floor, Wigglesworth House, 69 Southwark Bridge Road, London SE1 9HH
 Tel: +44 (0)20 7803 2420
 web: www.thespiritsbusiness.com

THE SPIRITS BUSINESS



WEB & SOCIAL.

Updated daily with relevant and timely news, interviews and features from the global drinks industry, *thespiritsbusiness.com* is viewed by around 452,000 unique users each month.

With numerous display and sponsorship opportunities across both our websites and newsletters, brands can access a cost-effective platform with *The Spirits Business* to target our expanding global online readership.

In addition, we reach and influence thousands of followers every day via social media. Whether it is X (formerly Twitter), Instagram, Threads, Facebook or LinkedIn, we are constantly engaged with key industry figures and consumers.

Monthly stats:

Unique users: 452,000
Visits from more than 217 countries

Social media channels:

Twitter: 30.1k Followers
Facebook: 22k followers; 19.6k page likes
Instagram: 17.3k followers; 150+ likes per post
LinkedIn: 118k followers

Close to 23,000 people subscribe to our daily newsletter, which gives you the chance to advertise to a global digital audience. Plus, we have a US-focused edition covering the latest developments in the States.

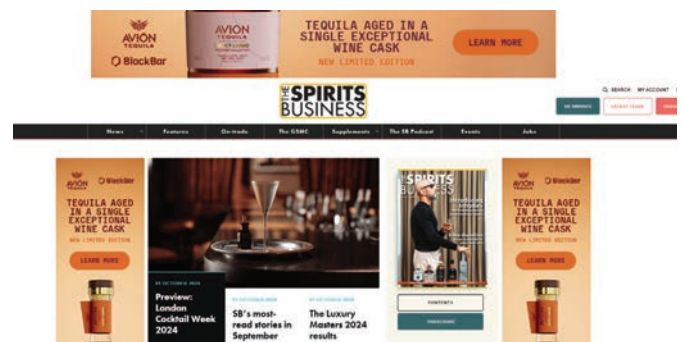
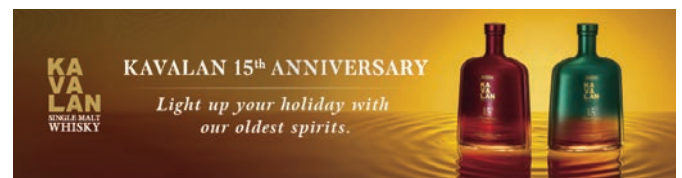

Top 20 countries

- | | |
|--------------|-------------|
| US | Singapore |
| UK | Mexico |
| India | Sweden |
| Canada | Spain |
| Australia | Italy |
| Ireland | Malaysia |
| South Africa | UAE |
| France | Japan |
| Germany | Philippines |
| Netherlands | New Zealand |



FEATURES LIST

As the must-read publication for the international spirits trade, our 2025 features list is more varied than ever before. Spanning established categories such as Scotch, gin and vodka to up-and-coming disruptive sectors, plus numerous global reports, our schedule will help you plan your most effective marketing strategy yet.

Month	Features	Awards results	Additional distribution
January	Most Innovative Spirits list Spirits trends to watch Category reports: Japanese whisky; RTDs	The Low & No Masters; Taste Masters 2024	WSWA Access Live
February	The Tequila issue Category reports: Tequila; Mezcal; Low/no-alcohol Regional report: UK Gin in travel retail Show preview: Wine Paris		Wine Paris; BCB Singapore
March	The Rum issue Category reports: Rum; Third-party spirits; Distributors/Importers Regional report: South Africa Show previews: IAADFS Summit of the Americas; ProWein	The Rum & Cachaça Masters	IAADFS Summit of the Americas; ProWein, Düsseldorf
April	The Vodka issue Category reports: Vodka; Tonics and mixers; Vermouth Regional report: Eastern Europe Tequila in travel retail Show preview: TFWA Asia	The Tequila & Mezcal Masters; The DB & SB Spring Blind Tasting	TFWA Asia
May	The Asia issue Category reports: Asian spirits; Cognac; Brandy Regional reports: China; US Irish whiskey in travel retail Show preview: BCB Brooklyn	The Cognac Masters; The Brandy Masters; The Asian Spirits Masters	BCB Brooklyn; London Wine Fair
June	The Brand Champions 2025* Category reports: Hard seltzers; SaaS/Software; Rum Regional report: Western Europe Vodka in travel retail Show preview: BCB London	The Pre-Mixed, RTD & Hard Seltzer Masters	BCB London
July	The Gin issue Category reports: Gin; Sustainability; Apéritifs Regional report: Middle East & Africa Show preview: Tales of the Cocktail	The Tonic & Mixer Masters; The Gin Masters – First Tasting	Tales of the Cocktail
August	The Whisky issue Category reports: Scotch whisky; World whisky; Spirits packaging Regional report: India	The Scotch Whisky Masters; The American Whiskey Masters; The Irish Whiskey Masters; The World Whisky Masters	
September	The Travel Retail issue Global travel retail report Category reports: Irish whiskey; Vodka; Rum Regional report: Australasia Show preview: TFWA World Exhibition & Conference	The Vodka Masters; The Travel Retail Masters	TFWA World Exhibition & Conference
October	The Luxury Spirits issue Category reports: Luxury spirits; American whiskey; Retailers; Low/no-alcohol Regional report: Scandinavia Show previews: BCB Berlin; London Cocktail Week	The Luxury Masters; The DB & SB Autumn Blind Tasting	BCB Berlin
November	The On-Trade issue Global Bar Report Category reports: Liqueurs; Tonics and mixers; French whisky Regional report: South America	The Liqueur Masters; The Speciality Spirits Masters	
December	World Spirits Report Category reports: SaaS/Software; Sustainability; Gin; Spirits packaging Regional report: North America Rum in travel retail	The Design & Packaging Masters; The SB Awards; The Gin Masters – Second Tasting	

* The definitive guide to spirits brands selling more than one million nine-litre cases per annum. The Brand Champions supplement will contain exclusive and comprehensive data on spirits brands' sales volumes, equipping industry professionals with unparalleled information relevant to this dynamic industry.



THE SPIRITS BUSINESS PODCAST

Available to listen to on all major streaming platforms, including Spotify and Apple Podcasts. Contact our commercial team to learn more about advertising and sponsorship opportunities.



THE GLOBAL SPIRITS MASTERS COMPETITIONS 2025

Launched in 2008, The Global Spirits Masters Competitions rates and rewards excellence in spirits production, giving brands key differentiation in a crowded market.

Judging is divided into 22 separate competitions to ensure each spirit category is given the utmost attention by specialist judges.

The Global Spirits Masters Competitions is unique in its exclusive use of completely independent expert judges, including journalists, retail buyers, bartenders and educators. As such, entrants can rest assured that their product has been assessed constructively and without bias by our panels of professionals. Judges can award Silver, Gold and Master medals, as well as additional Taste Master awards for outstanding excellence.

The Global Spirits Masters Competitions 2025

Masters	Entry deadline	Sample deadline	Judging	Results published
Low & No-Alcohol	22 November	29 November	December	January
Rum & Cachaça	17 January	28 January	February	March
Tequila & Mezcal	14 February	25 February	March	April
Cognac	14 March	25 March	April	May
Brandy	14 March	25 March	April	May
Asian Spirits	21 March	1 April	April	May
Pre-Mixed, RTD & Hard Seltzer	18 April	29 April	May	June
Tonic & Mixer	2 May	13 May	June	July
Gin (First Tasting)	16 May	27 May	June	July
Scotch Whisky	13 June	24 June	July	August
Irish Whiskey	13 June	24 June	July	August
American Whiskey	20 June	1 July	July	August
World Whisky	20 June	1 July	July	August
Vodka	18 July	29 July	August	September
Travel Retail	23 July	1 August	August	September
Luxury	15 August	26 August	September	October
Liqueur	19 September	30 September	October	November
Speciality	19 September	30 September	October	November
Gin (Second Tasting)	17 October	28 October	November	December
Design & Packaging	24 October	4 November	November	December
Low & No	14 November	25 November	December	January 2026

The Drinks Business & Spirits Business Blind Tastings 2025

DB & SB Spring Tasting	21 February	4 March	March	April
DB & SB Autumn Tasting	15 August	26 August	September	October

Further competitions & awards by *The Spirits Business*

The Spirits Business Awards 2025	12 August	August	November
The Alan Lodge Young International Drinks Writer of the Year	12 August	August	November

THE SPIRITS BUSINESS AWARDS



THE SPIRITS BUSINESS AWARDS 2025

The Spirits Business Awards aims to reward those driving excellence across the industry from retailers and distributors to marketers, brands, distillers and blenders. Judged by members of *The Spirits Business* editorial team and a panel of independent spirits experts, the awards are separated into five areas: Retail and Marketing, Sustainability and Innovation, Tourism, Products, and People.

Through these awards we want to recognise the people and brands who continue to push the boundaries of innovation – including those working hard behind the scenes.

Categories

Retail & Marketing

- Spirits Retailer of the Year
 - E-Commerce
 - Specialist
 - Supermarket
- Spirits Distributor of the Year
- Spirits Bottler of the Year
- Best Spirits PR Company
- Best Marketing Campaign
- Best Event

Sustainability & Innovation

- Spirits Sustainability Award
- Ethical Award
- Innovation in Production
- Innovation in Packaging

Culture & Tourism

- Distillery Consumer Experience Award
- Cultural Contribution to the Spirits Industry
- Bar of the Year

Products & Brands

- Best New Product
- Brand of The Year
 - Whisky/Whiskey
 - Gin
 - Vodka
 - Speciality (Low & No/ Liqueurs / Pre-Mixed/ Other)
 - Tequila/ Mezcal
 - Brandy/ Cognac
 - Rum/ Cachaça

People

- Blender of the Year
- Distiller of the Year
- Young Achiever of the Year
- Bartender of the Year
- Lifetime Achievement Award



KAVALAN

MASTER OF MALT Trade

GINA JUICE

PER SE

Tiptle



AIX



GCA SPIRITS

DESI DARU



Union Press, Fourth Floor, Wigglesworth House, 69 Southwark Bridge Road, London SE1 9HH
Tel: +44 (0)20 7803 2420
web: www.thespiritsbusiness.com

THE SPIRITS BUSINESS



THE SB TRAVEL RETAIL BEACH PARTY

The Spirits Business has a thriving events portfolio, and part of that includes our annual SB Travel Retail Beach Party, which takes place during the TFWA World Exhibition & Conference in Cannes, France.

Last year, we welcomed a record number of guests – more than 400 – to enjoy a broad selection of spirits, cocktails and wine as the sun set on the French Riviera.

In 2025, we will be returning for another unmissable evening of networking and celebration.

We have a number of sponsorship and partner opportunities available and would be delighted to discuss with interested parties how we can work together.



Technical specifications for THE SPIRITS BUSINESS

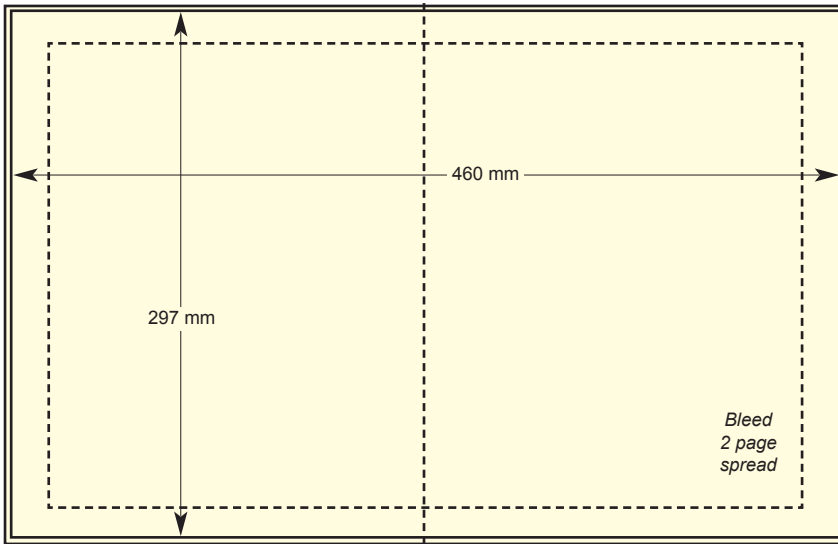

Double Page Spread

Bleed: 303 mm x 466 mm
Trim: 297 mm x 460 mm

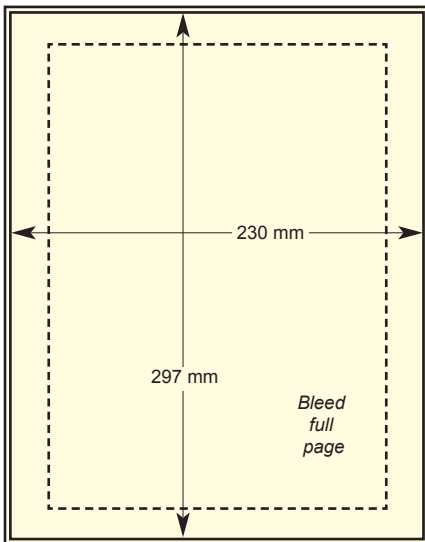

PERFECT BINDING:

Please be aware that all of our magazines are perfect bound. It is the designer's responsibility to include double gutter image allowance if it is required. Also, we recommend that no type, logo or any important matter should appear within 8mm either side of the gutter on any spread to avoid being obscured.

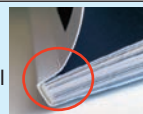

Full Page

Bleed: 303 mm x 236 mm
Trim: 297 mm x 230 mm

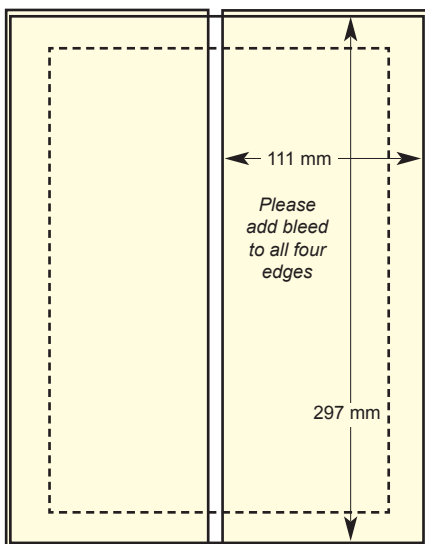

Half Page Vertical

Bleed: 303 mm x 118 mm
Trim: 297 mm x 112 mm

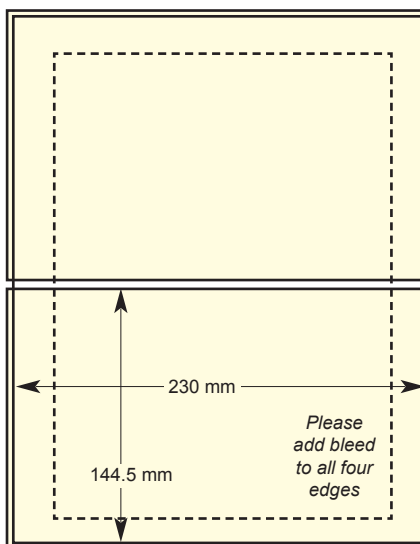

Half Page Horizontal

Bleed: 151 mm x 236 mm
Trim: 145 mm x 230 mm

COPY REQUIREMENTS

We require that all copy be supplied only in digital format, and as specified below.

ACCEPTABLE FORMATS:

- **Print Optimised (high resolution) PDF to PDF/X-1a:2001 standard, otherwise,**
- **High-resolution CMYK flat bitmap file (eg TIFF, PSD or JPG format)**
- Please always include crop marks and 3mm of bleed on ALL FOUR EDGES
- Max ink coverage = less than 290%
- If you use ICC profiles, please set your output to FOGRA39 (ISO 12647-2:2004)
- Please do **NOT** send us live files such as InDesign, Illustrator or Quark documents

IMPORTANT: All artwork must be converted to CMYK before sending. In all instances where colour fidelity is critical, a certified colour match is required two weeks prior to printing.

DELIVERY to the Production Dept:

For files up to 25Mb (approx) in size

- Send your PDF file/s by email to: production@unionpress.co.uk

For files over 25Mb in size:

- We would recommend use of one of the free-of-charge online services such as **wetransfer, hightail, sendspace, dropbox** or any other such similar site.

We will check and preflight supplied files against our standard print profiles and return a summary acknowledgement of receipt and suitability for use. If problems are found in any files we will contact the sending party to make amendments.

PRODUCTION CONTACT: Mile Budimir | direct: +44 (0)20 7803 2456 | mobile: +44 (0)7388 876515 | email: production@unionpress.co.uk

Technical specifications for THE SPIRITS BUSINESS

PLEASE REMEMBER TO SEND A LINK WITH YOUR ARTWORK – AT LEAST HALF OF ALL BANNERS ARE SUBMITTED WITHOUT ONE AND IT IS, BY FAR, OUR MOST COMMON REASON FOR DELAY...

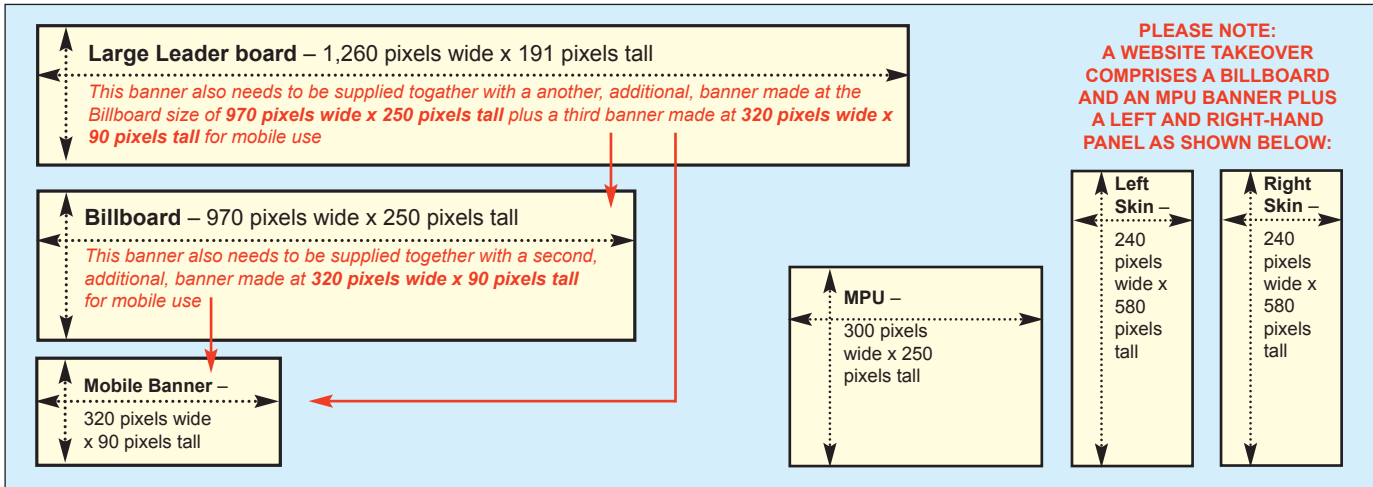

ONLINE ADVERTISING SPECIFICATIONS:

WEBSITE BANNERS AND BUTTONS:

Banner Description	Dimensions (width x height)	Maximum file size	Acceptable file types & technical notes (Please note Flash-based adverts are no longer supported anywhere)
Large Leaderboard *	1,260 pixels x 191 pixels	200Kb	JPG, PNG, GIF, HTML5**, Third-party tag (see sizing note below)
Billboard *	970 pixels x 250 pixels	200Kb	JPG, PNG, GIF, HTML5**, Third-party tag (see sizing note below)
MPU (Mid Page Unit)	300 pixels x 250 pixels	200Kb	JPG, PNG, GIF, HTML5**, Third-party tag
Button	150 x 150 pixels	200Kb	JPG, PNG, GIF
Mobile	320 pixels x 90 pixels	200Kb	JPG, PNG, GIF, HTML5**, Third-party tag

Site Takeover A site takeover is a combination position that includes a **Billboard**, **MPU** and **TWO side panels** that will follow the viewers progress up and down the page. As a result, we need to get hold of the following sizes of artwork:
 1 x **Billboard**: 970 pixel wide x 250 pixel tall + an additional 320 pixel wide x 90 pixel tall mobile version
 1 x **MPU**: 300 pixel wide x 250 pixel tall
 2 x **Side panels**: 240 pixel wide x 580 pixel tall (left-hand side) + 240 pixel wide x 580 pixel tall (right-hand side)

PLEASE NOTE:

* **Large Leaderboard & Billboard banner positions** need to be supplied together with additional banners in order to work. When supplying artwork for the **Large Leaderboard** we need **THREE banners** – made at **1,260 x 191 pixels**, **970 x 250 pixels** and **320 x 90 pixels**. When supplying artwork for the **Billboard** we need **TWO banners** banners – made at **970 x 250 pixels** and **320 x 90 pixels**.

** **HTML5** can be supplied as third-party tag, DoubleClick Studio creative, DCM tag or as self-contained HTML5 in a single-code snippet. Where artwork is run as HTML, we would request that you respect our audience experience and refrain from using pop ups, pop unders, ad pushdown or any above page, floating or between layer windows. Audio and video can be used in banner as a third-party tag streaming from your video provider with stop, pause, play and audio control buttons required. HTML banners should not exceed 15 file requests during initial file load and host-initiated subload and all files for the banner (.html, .js, .css, images, etc.) must be included as part of the maximum file weight calculation for all file load limits.

NEWSLETTER BANNERS AND BUTTONS:

Banner Description	Dimensions (width x height)	Maximum file size	Acceptable file types
Main Body Banner	632 pixels x 90 pixels	200Kb	JPG, PNG, GIF
Button	150 x 150 pixels	200Kb	JPG, PNG, GIF

PLEASE NOTE:

It is not possible to run or embed assets that require server-side technologies within an email newsletter; we only support static files in JPG and PNG format and animations in GIF format. Furthermore, please be aware that certain email clients deliberately stop GIF animations for security reasons (eg, some versions of Microsoft Outlook) and only show a static image (for more explanation: <https://support.microsoft.com/en-us/office/the-animated-graphic-in-my-e-mail-message-doesn-t-work-a5e8a2a3-9d86-4203-8920-c88cb8739e34>) as a result we would recommend keeping all of the most important information in the first frame of your animation.

ARTWORK DELIVERY:

Please submit your completed artwork to: **production@unionpress.co.uk** for initial checking and pre-approval. On completion we will return a summary acknowledgement of receipt and suitability for use. However, if problems are found in the supplied files we will contact the sending party to make them aware of the issue and may suggest amendments. We will always do our best to ensure that artwork will work across all browsers and platforms, but cannot make any guarantees in material supplied to us.

PRODUCTION CONTACT: Mile Budimir | direct: +44 (0)20 7803 2456 | mobile: +44 (0)7388 876515 | email: production@unionpress.co.uk

CONTACT SALES & EVENTS

Richard Cochrane

Managing Director
Tel: +44 (0) 207 803 2449
Mob: +44 (0) 7887 606866
Email: richard.cochrane@thespiritsbusiness.com

Ryan Graves

Deputy Managing Director
Tel: +44 (0) 207 803 2424
Mob: +44 (0) 7527 362 471
Email: ryan.graves@thespiritsbusiness.com

Rhiannon Morris

Sales & Marketing Manager
Tel: +44 (0) 207 803 2430
Email: rhiannon.morris@thespiritsbusiness.com

Christelle Monges

Senior Sales & Marketing Executive
Tel: +44 (0) 207 803 2420
Email: christelle.monges@thespiritsbusiness.com

Sophie Allan

Events Director
Tel: +44 (0) 207 803 2442
Email: sophie.allan@thespiritsbusiness.com

Aasiya Sackey

Events Executive
Tel: +44 (0) 207 803 2420
Email: aasiya.sackey@thespiritsbusiness.com

CONTACT EDITORIAL

Melita Kiely

Editor-in-Chief
Tel: +44 (0) 207 803 2436
Email: melita.kiely@thespiritsbusiness.com

Nicola Carruthers

Deputy Editor
Tel: +44 (0) 207 803 2444
Email: nicola.carruthers@thespiritsbusiness.com

Georgie Collins

Digital Editor
Tel: +44 (0) 207 803 2433
Email: georgie.collins@thespiritsbusiness.com

Lauren Bowes

Bars Editor
Tel: +44 (0) 207 803 2420
Email: lauren.bowes@thespiritsbusiness.com

Rupert Hohwieler

Senior Staff Writer
Tel: +44 (0) 207 803 2425
Email: rupert.hohwieler@thespiritsbusiness.com

Miona Madsen

Content Writer
Tel: +44 (0) 207 803 2420
Email: miona.madsen@thespiritsbusiness.com

Ted Simmons

US Correspondent
Tel: +44 (0) 207 803 2420
Email: ted.simmons@thespiritsbusiness.com