

Automation  
Simplified...



Solenoid Valve

Angle Seat Valve

Rotary Coupling

Pneumatic Directional Control Valve

Actuator

Cylinder

One Touch Fitting

Ball Valve

Butterfly Valve

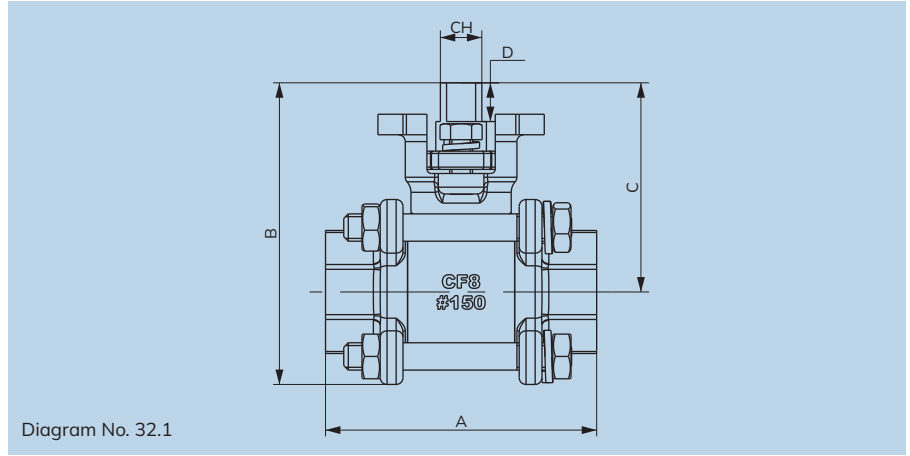

**Specifications**

Size :	DN15 - DN100
End Connection :	Screwed end (BSP / NPT), Socket Weld
Face to Face :	MFG. Standard
Design Standard :	ASME B16.11, ASME B16.34, API 598, BS EN ISO 17292, ISO 5211
Pressure Class :	150#, 300#
Body Material :	CF8 / CF8M / WCB / CF3M
Pipe End Material :	CF8 / CF8M / WCB / CF3M
Ball Material :	CF8 / CF8M
Body Seal Material :	PTFE / RPTFE / CFT / GFT / PEEK
Seat Ring Material :	PTFE / RPTFE / CFT / GFT / PEEK
Fastener Material :	SS304 / SS316
Stem Seal Material :	PTFE / RPTFE / CFT / GFT / PEEK
Stem Material :	SS304 / SS316 / SS410
Gland Bush Material :	SS304 / SS316 / SS410
Gland Material :	SS304 / SS316 / SS410

**Features**

- 3PC design twinned ball valve.
- Full port ball valve.
- Blow out proof stem.
- Floating ball design.
- Hand Lever / Gear / Actuator Operated.
- Face to Face:- MFG standard.
- End Connection:- Screwed / Socket weld (ASME B16.11).
- Balls are precision machined and mirror finished for bubble-tight shut off with less operating torque.
- ISO 5211 top mounting pad available for easy Uflow make actuator mounting.

**Section View**

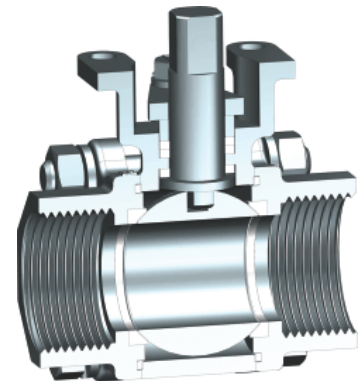

All dimensions are approx.

**Dimension** (All dimensions in mm)

Model No.	Diagram No.	Pipe (Inch)	A	B	CH	D	C	ISO 5211
JC-2R	32.1	½"	59.50	66	9.1	8.5	46	F03
JC-3R	32.1	¾"	57	71	9.1	9	50	F03
JC-4R	32.1	1"	75.70	90	11	13.5	61.5	F05
JC-5R	32.1	1¼"	85	102.7	11	13	70	F05
JC-6R	32.1	1½"	93.60	110	11	13	73.5	F05
JC-8R	32.1	2"	109	139.6	14	15.5	94	F05
JC-9R	32.1	2½"	139	173	14	15	108.5	F07
JC-AR	32.1	3"	166	195	17	16.5	119.5	F07
JC-BR	32.1	4"	193	236	22	23	144	F07

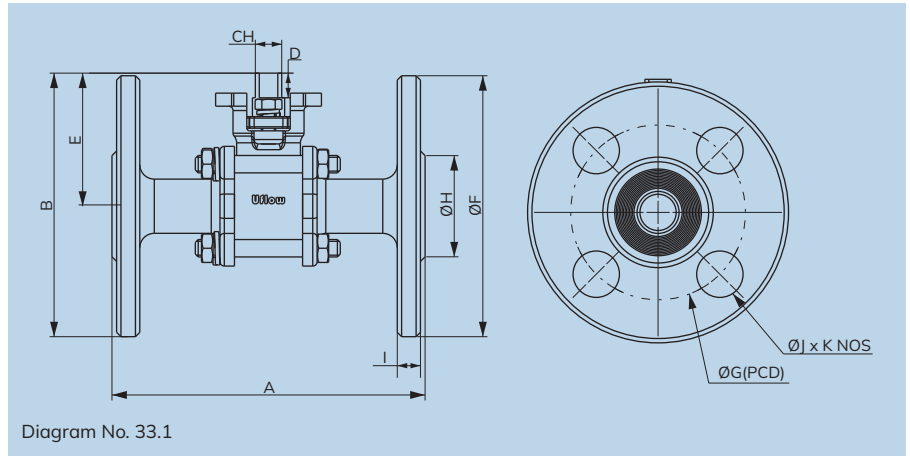

### Specifications

Size :	DN15 - DN100
End Connection :	Flange end
Face to Face :	ASME B 16.10 (Flange end)
Pressure Class :	150#, 300#
Design Standard :	ASME B16.10, ASME B16.25, ASME B16.34, ASME B16.5, API 598, BS EN ISO 17292, ISO 5211
Body Material :	CF8 / CF8M / WCB / CF3M
Tail Piece Material :	CF8 / CF8M / WCB / CF3M
Ball Material :	CF8 / CF8M
Body Seal Material :	PTFE / RPTFE / CFT / GFT / PEEK
Seat Ring Material :	PTFE / RPTFE / CFT / GFT / PEEK
Fastener Material :	SS304 / SS316
Stem Seal Material :	PTFE / RPTFE / CFT / GFT / PEEK
Stem Material :	SS304 / SS316 / SS410
Gland Bush Material :	SS304 / SS316 / SS410
Gland Material :	SS304 / SS316 / SS410

### Features

- 3PC design twinseal ball valve.
- Full port ball valve.
- Blow out proof stem.
- Floating ball design.
- Hand Lever / Gear / Actuator Operated.
- Face to Face:- ASME B16.10.
- End Connection:- Flanged (ASME B16.5), Butt-weld (ASME B16.25)
- Balls are precision machined and mirror finished for bubble-tight shut off with less operating torque.
- ISO 5211 top mounting pad available for easy Uflow make actuator mounting.

### Section View

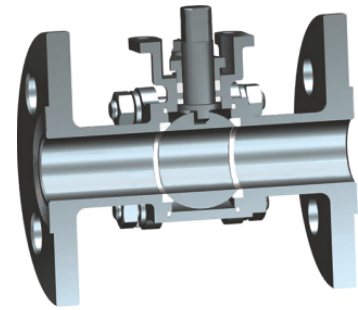

### Dimension (All dimensions in mm)

All dimensions are approx.

Model No.	Diagram No.	Pipe (Inch)	A	B	CH	D	E	F	G	H	I	J	K	ISO 5211
JC-2DR	33.1	½"	108	91	9.1	8.5	46	90	60.5	35	8	16	4	F03
JC-3DR	33.1	¾"	117	100	9.1	9	50	100	70	44.5	9	16	4	F03
JC-4DR	33.1	1"	127	117	11	13.5	61.5	110	79.5	48	9.6	16	4	F05
JC-5DR	33.1	1¼"	140	127	11	13	70	115	89	63.5	11.2	16	4	F05
JC-6DR	33.1	1½"	165	136	11	13	73.5	125	98.5	73	12.5	16	4	F05
JC-8DR	33.1	2"	178	169	14	15.5	94	150	121	92	14.5	19	4	F05
JC-9DR	33.1	2½"	190	198.5	14	15	108.5	180	139.5	105	16	19.5	4	F07
JC-ADR	33.1	3"	203	214.5	17	16.5	119.5	190	152.5	127	17.5	19.5	4	F07
JC-BDR	33.1	4"	229	259	22	23	144	230	190.5	157	22.5	19	8	F07

# JC -SERIES 3 PC BALL VALVE FULL BORE MODEL CHART

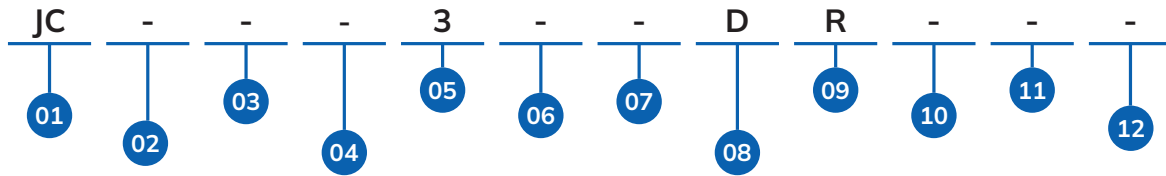

01	SERIES
JC	

02	PRODUCT TYPE
-	3PC Ball Valve Full Bore

03	BODY MATERIAL
-	CF8
M	CF8M
V	CF3M
F	CF3
W	WCB
J	WCB-MR0103
H	WCB-MR0175

04	SEAL MATERIAL
-	PTFE
R	RPTFE
T	CFT
L	GFT
K	PEEK
P	PCTFE

05	PORT SIZE
2	1/2"
3	3/4"
4	1"
5	1-1/4"
6	1-1/2"
7	3/8"
8	2"
9	2-1/2"
A	3"
B	4"

06	STEM/BALL MATERIAL
-	CF8/SS 304
M	CF8M/SS 316
V	CF3M/SS 316L
F	CF3/SS 304L

07	PRESSURE CLASS
-	150#
B	300#
1	PN40

08	PORT CONNECTION
-	BSP
N	NPT
P	BSPT
D	Flange End
T	Tri Clamp
S	Socket
W	Buttweld
A	Flat Face Flange End

09	OPERATION
-	Actuator Operated
R	Bare Stem
E	Electric Actuator Operated
G	Gear
U	Manual Operated
L	Manual With Limit Switch
4	Manual Operated Ss304

10	APPROVALS
-	NO APPROVALS

11	CONFIG
-	REGULAR
C1	CONFIG 1
C2	CONFIG 2
C3	CONFIG 3
⋮	⋮
C9	CONFIG 9
CA	CONFIG 10
CB	CONFIG 11

12	VERSION
-	VERSION 0
V1	VERSION 1
V2	VERSION 2
V3	VERSION 3
⋮	⋮
V9	VERSION 9
VA	VERSION 10
VB	VERSION 11

**JC-3DR**  
3/4" 3PC BALL VALVE FULL BORE CF8-PTFE-CF8/SS304-150#-  
FLANGE END-BARE STEM

Note : The above chart is for identification purposes only, and it may not be possible to make all combinations for the above chart.

# Global Presence...



Made In India



## CONTACT US:

For Domestic Inquiry

✉ [sales@uflowvalve.com](mailto:sales@uflowvalve.com) 📞 +91 85110 98822 🌐 [www.uflowvalve.com](http://www.uflowvalve.com)

For Export Inquiry

✉ [export@uflowvalve.com](mailto:export@uflowvalve.com) 📞 +91 99744 77370 📞 +91 78018 09550

📍 Uflow Automation, Ankur Industrial Complex, Survey No: 275/276, Plot No: 31, Nr. Intol Cast Pvt. Ltd. Shapar(Veraval) Dist.: Gujarat (India) - 360 024.