



# SPIRAL MIXERS WITH GUARDS

**#348SM20** • 20 Qt.

**#348SM30** • 30 Qt.

# INDEX

Safety Information ..... 2  
 Operation ..... 3  
 Specifications & Capacities ..... 5  
 Cleaning..... 6  
 Circuit Diagram .....7  
 Troubleshooting..... 8



Intertek  
5017744



Intertek  
5017744

---

CONFORMS TO UL-763  
 CONFORMS TO NSF-8  
 CONFORMS TO CAN/CSA C22.2 no. 195

# SAFETY INFORMATION

**When using electrical appliances, basic safety precautions should always be followed, including the following:**

1. Keep the working area around the machine clean and organized.
2. Consider environmental conditions surrounding the machine. Do not use the machine in humid, wet, or poorly lit environments. Do not use the machine close to flammable liquids or gas.
3. Keep machine away from children and non-authorized personnel. Do not permit them to go near the machine or its working area.
4. Do not touch the switch or cable with wet hands.
5. Ensure unit's plug is compatible with your electrical outlet's voltage.
6. Do not wear loose clothing or items that may get caught in the machine. Wear non-slip shoes while working with the machine. For hygiene and safety, keep hair tied back and wear protective gloves.
7. Do not tug on the cable to remove the plug from the outlet. Do not leave the cable near sharp objects, water, or solvents.
8. Remove the plug when the machine is not in use, during cleaning, or when you need to move the machine.
9. Check that the machine is not damaged prior to each use. Carefully check that all safety devices are working, the removable parts are not blocked, there are no parts damaged, all the parts have been set up correctly, and all conditions that could influence the regular function of the machine are in working order.
10. If the machine is damaged or there are issues during its use, turn off the machine immediately and contact the manufacturer for assistance or repair. Repairs should only be made by qualified technicians, using the correct manufacturer parts. Non-compliance with these rules may void the warranty.

**Note:** Save these instructions for future reference.

## PRIOR TO OPERATION

1. Install 4 rubber feet.
2. Check the machine for defects or damages caused during transportation.
3. Place the machine on a stable and level surface.
4. Connect the cord to the power supply.

## OPERATION

**Note:** The timer must be set to a value greater than 0 or the mixer will not run.

1. Before use, confirm the power supplied to the unit is correct. Run the machine empty for a few seconds to confirm that no moving parts are colliding and there is no abnormal noise. Failure to do so may cause damage to your machine and void the warranty.
2. In a clean bowl, add water first, then add flour. Return the protective cover to the closed and locked position.
3. Startup steps:

- a. Once the bowl guard is in place, set the time.

**Note:** The timer readout is stationary and will not move during countdown.

- b. The emergency stop button will pop up. Do not operate the machine if the emergency stop button does not function.
- c. Press the green button to start slow speed mixing.
- d. After the water and flour are mixed, press the red stop button followed by the yellow button to start high speed mixing. The machine will automatically stop when the timer runs out.

**Note:** As a safety feature, the bowl guard must be down in position in order for the dough mixer to operate. If the guard is lifted up, the mixer will not run.

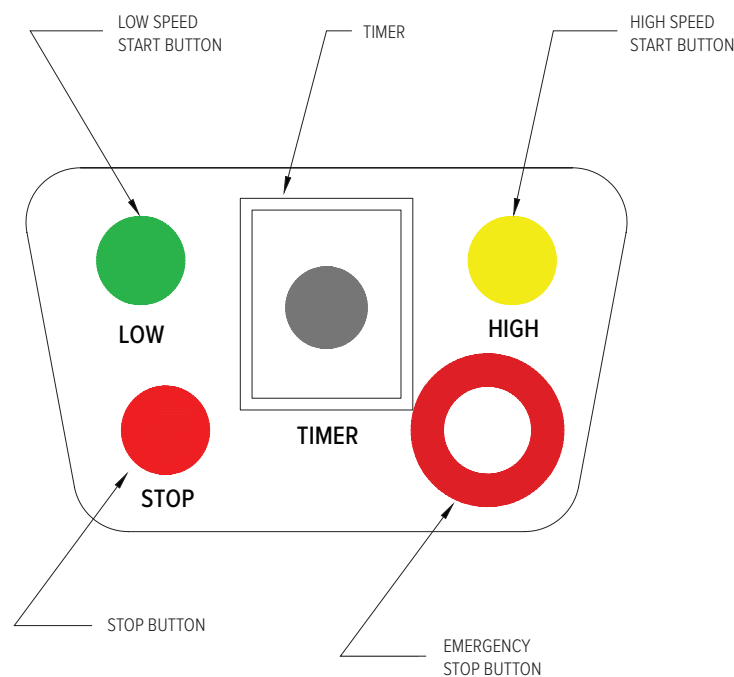

## STOPPING THE MACHINE

In addition to the timer cycle completing, the machine will also stop while in use if:

1. The safety guard is lifted while in use.
2. The emergency stop button is pressed.

## RESETTING THE MACHINE

If the machine was stopped using the emergency stop button, rotate the button to the right and pop it back up in order to operate again.

If your machine stopped due to overload, proceed to the overload reset instructions to reset the machine.

## OVERLOAD RESET INSTRUCTIONS

1. In order to reset the overload switch, users must first wait for the machine to cool down (approximately 15-30 minutes).
2. Unplug the machine.
3. Identify the overload protection switch on your machine:
  - a. Check for an overload reset button on the backside of the machine. If you can locate the reset button, press it down. The machine will be reset.
  - b. If your reset button does not appear on the back of the machine, proceed to the below steps:
4. Remove the top cover of the machine by unscrewing all fastening hardware.
5. Press the overload protection switch.
6. Install the lid again, plug the unit back into the power source, and turn on the machine.

## HOW TO INSTALL THE CASTERS

**(OPTIONAL ACCESSORY - ITEM # 348PSMCASTER)**

1. There are 2 hex nuts per caster. Remove the top hex nut from the caster in preparation for the install.
2. Move the hex nut at the bottom of the caster to the desired height (to allow the rod enough clearance for insertion).
3. Align the caster rod with the hole at the foot's base, and then guide the caster rod through the base.
4. Secure the rod on the inner side of the base with the remaining hex nut.
5. Tighten both the inner hex nut and outer hex nut to form a tight clamp on either side of the base, securing the caster in place.

# USAGE GUIDELINES

To extend the life of your mixer’s motor, it is recommended that after each batch of dough is completed, you allow the mixer to rest for 5-10 minutes, allowing the motor to cool.

\*Maximum mixing time of a single batch is 10 minutes.

\*Mixer can be used intermittently 8 hours per day, following the usage and rest periods above.

# CAPACITY CHART

\*For best performance, it is recommended to use the mixers at least at 30% capacity.

\*When mixing dough (pizza, bread, or bagels), check your "AR" absorption ratio - water weight divided by flour weight. The below capacities are based on 12% flour moisture at 70°F water temperature.

If high gluten flour is used, reduce below dough batch size by 10%.

**Example: If recipe calls for 6 lb. of water and 10 lb. of flour, then 6 divided by 10 = 0.6 (60% AR).**

PRODUCT	348SM20		348SM30	
	FLOUR/LB.	BATCH/LB.	FLOUR/LB.	BATCH/LB.
<b>Bread 60% AR</b>	17.6	28.2	26.4	42.2
<b>Whole Wheat</b>	17.6	/	26.4	/
<b>Thin Pizza 40% AR</b>	8.8	12.3	13.2	18.5
<b>Med. Pizza 50% AR</b>	17.6	26.4	26.4	39.6
<b>Thick Pizza 60% AR</b>	17.6	28.2	26.4	42.2
<b>Pie Dough</b>	17.6	/	26.4	/
<b>Bagel 50% AR</b>	17.6	26.4	26.4	39.6
<b>Minimum Capacity</b>	2.2	3.3	3.3	5

# SPECIFICATIONS & CAPACITIES

	<b>348SM20</b>	<b>348SM30</b>
<b>Bowl Capacity</b>	20 QT.	30 QT.
<b>Flour Capacity</b>	17.6 LB.	26.4 LB.
<b>Minimum Flour Capacity</b>	2.2 LB.	3.3 LB.
<b>Dough Capacity (60% AR)*</b>	28 LB.	42 LB.
<b>Voltage</b>	120V	120V
<b>Wattage</b>	1500W	1500W
<b>Horsepower</b>	2HP	2HP
<b>Phase</b>	Single	Single
<b>Mixing Speed (Low)</b>	112 RPM	112 RPM
<b>Mixing Speed (High)</b>	198 RPM	198 RPM
<b>Machine Weight</b>	200 LB.	220 LB.

## CLEANING

1. After removing dough from the bowl, turn off the power and unplug the machine.
2. Use a cloth with a mild detergent and warm water to clean the inside of the bowl. Make sure to clean the spiral hook and auxiliary rod.
3. Use a clean cloth soaked in warm water to rinse the inside of the bowl. Try to avoid getting excess amounts of water inside the bowl.
4. Use a dry, clean cloth to remove excess water and dry the machine.

**NOTE:** Cleaning should be done at the end of every work day and when switching between batches of product.

**NOTE:** It is NOT advised to remove the attachments from this unit.

# CIRCUIT DIAGRAM

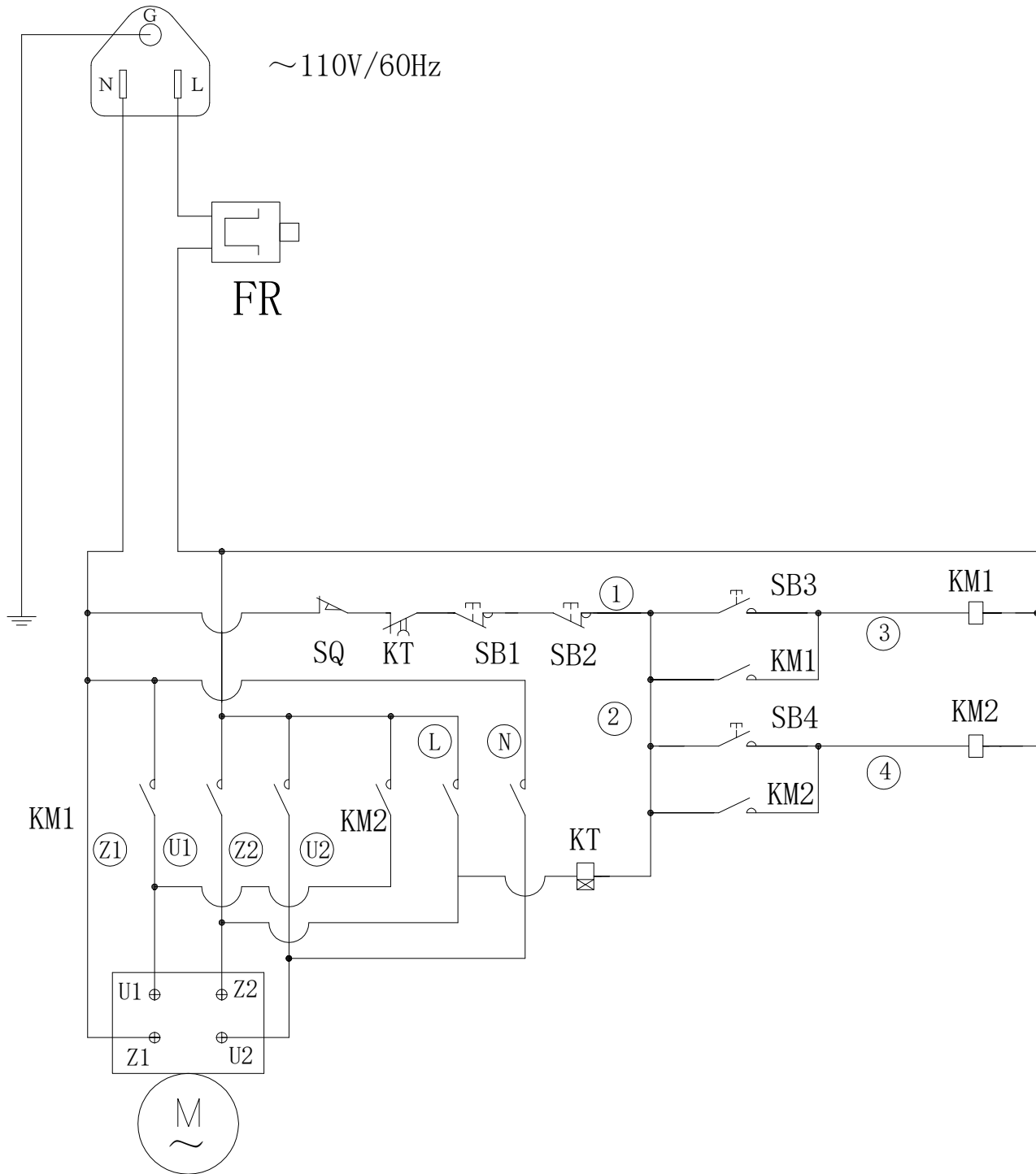

# TROUBLESHOOTING

ISSUE	CAUSE	SOLUTION
The axles do not work when operating the machine.	Poor contact of the electrical equipment.	Check that the plug is securely fitted into the outlet.
The mixing bowl is out of position.	Moving direction is not correct.	Check to see that everything is aligned correctly.
Leaks oil.	Sealing washer is damaged.	Replace the sealing washer.
The motor is overheated, and the speed is down.	The voltage is not high enough, or the incorrect speed is set for the thickness of dough.	Check the voltage or use a lower speed.
Noisy and overheating.	Poor lubrication.	Add or change lubrication to moving parts.
Mixer touches bowl.	The mixing device or bowl is deformed.	Repair or change the bowl or mixing device.
Machine trips the breaker and does not turn on again.	Other machines in the kitchen start or work at the same time, resulting in voltage instability or voltage fluctuations. The overload protection switch pops up.	<ol style="list-style-type: none"> <li>1. Your machine will need reset. Check for the reset button on the back of the machine. If there is no reset button, proceed to step 2 to locate the reset inside the machine.</li> <li>2. Unscrew and open the lid.</li> <li>3. Press the overload protection switch (reset button).*See below</li> <li>4. Install the lid, plug it back in, and turn on the machine.</li> </ol>



\*Overload Protection Switch