

# FLEETFLEX

ELECTRICAL SYSTEM

## OWNER'S MANUAL

*Original Instructions*

September 15, 2011  
Lit. No. 49514, Rev. 01



**Minute**  
**Mount<sup>2</sup>**  
SYSTEM

**⚠ CAUTION**

Read this document before operating or servicing snowplow.

This manual supersedes all editions with an earlier date.

# SNOWPLOW OWNER DATA SHEET

---

---

*Register your snowplow online at [www.fisherplows.com](http://www.fisherplows.com)*

Owner Name: \_\_\_\_\_

Date Purchased: \_\_\_\_\_

Distributor Name: \_\_\_\_\_ Phone: \_\_\_\_\_

Distributor Address: \_\_\_\_\_

Vehicle Model/Year: \_\_\_\_\_

Snowplow Model/Year: \_\_\_\_\_

Snowplow Type/Size: \_\_\_\_\_ Weight: \_\_\_\_\_ lb/kg

Ballast: No \_\_\_ Yes \_\_\_ Amount \_\_\_\_\_ lb/kg

Insta-Act® Hydraulic Unit Serial Number: \_\_\_\_\_

Blade Serial Number (located above Warning/Caution label): \_\_\_\_\_



# TABLE OF CONTENTS

Snowplow Owner Data Sheet .....	3	Cab Controls .....	27
Preface .....	7	Straight Blade Controls .....	28
Safety .....	8	XtremeV & XLS Controls .....	29
Vehicle Application Information .....	15	Accessories and Options .....	30
Ballast Requirements .....	16	Attaching Snowplow To Vehicle .....	33
Getting To Know Your Snowplow .....	17	Operating Your Snowplow .....	36
Minute Mount® 2 System .....	17	Controls .....	36
Blades .....	18	Straight Blade Hand-Held Control .....	36
HT Series™ Blades .....	18	Straight Blade Joystick Control .....	39
SD/HD/XBLADE™ Series .....	19	XtremeV/XLS Hand-Held Control .....	43
MC/XtremeV™/XLS™ Series .....	20	XtremeV/XLS Joystick Control .....	47
A-Frame/T-Frame .....	21	FLEET FLEX Electrical System .....	52
Straight Blade/HT Series A-Frames .....	21	SECURITY GUARD™ System .....	53
XLS A-Frames .....	21	Smooth Stop .....	57
XtremeV T-Frame/Push Assembly .....	21	One-Touch FLOAT .....	58
Headgear .....	21	XtremeV Blade Positions .....	59
Weights .....	22	XLS Blade Positions .....	62
Mount Kits .....	23	Snowplow Headlamp Check .....	65
INTENSIFIRE™ Snowplow Headlamps .....	23	Antiwear Shoe Adjustment .....	66
Insta-Act® Hydraulic Units .....	24	Hydraulic System .....	68
System Capacity .....	26	Blade Drop Speed Adjustment .....	69
Pump Motor Specifications (All Blades) .....	26	Scrape Lock Adjustment .....	70

# TABLE OF CONTENTS

---

---

Transporting Snowplow.....	73	XtremeV™ Cutting Edge Wear and Leveling Adjustment Procedure.....	89
Driving and Plowing on Snow and Ice .....	74	Hydraulic System .....	91
Plowing Snow.....	75	Fluid Level.....	91
General Instructions.....	76	Annual Fluid Change .....	93
Hard Packed Snow .....	76	Air Removal –	
Deep Snow .....	77	HT Series™/Straight Blades .....	98
Clearing Driveways.....	78	XtremeV Blades .....	99
Clearing Parking Lots .....	78	XLS™ Blades.....	100
Parking with Snowplow Attached.....	79	Hose or Fitting Replacement .....	101
Towing Disabled or Stuck Vehicle.....	79	Procedure for Installing Hydraulic Fittings and Hoses .....	102
Detaching Snowplow from Vehicle and Storage .....	80	Fuse Replacement .....	103
Maintenance.....	84	Vehicle.....	104
Aiming Headlamp Beams.....	84	Recycle .....	104
Preseason Check.....	86	Emergency Parts/Tools.....	105
Postseason Maintenance.....	87	Troubleshooting.....	106
Maintenance and Adjustment.....	88	Harness Diagrams – 3-Port, 2-Plug System.....	107

# PREFACE

---



This manual has been prepared to acquaint you with the safety information, operation and maintenance of your new FISHER® snowplow. Please read this manual carefully and follow all recommendations.

Before installing a snowplow, make sure your vehicle is equipped with all the vehicle manufacturer's and our required options for plowing. This will help ensure profitable and trouble-free operation of your snowplow. Keep this manual accessible. It is a handy reference in case minor service is required.

Your FISHER snowplow Insta-Act® hydraulic unit and blade both have a serial number. Record these serial numbers on the Snowplow Owner Data Sheet at the front of this manual to refer to when necessary.

When service is necessary, bring your snowplow to your local FISHER outlet. They know your snowplow best and are interested in your complete satisfaction.

The illustrations found in this manual represent typical components. They may not match your exact installation.

Most of the information in this Owner's Manual applies to all Minute Mount® 2 applications. Differences between straight-blade, HT Series™, XtremeV™ and XLS™ applications are called out in the text, or under separate headings, as required. Pages that apply only to one are called out as STRAIGHT BLADE, ,  or  on the outside corner of the page heading.

# SAFETY

---

## SAFETY DEFINITIONS

### **WARNING**

Indicates a potentially hazardous situation, that if not avoided, could result in death or serious personal injury.

### **CAUTION**

Indicates a potentially hazardous situation that, if not avoided, may result in minor or moderate injury. It may also be used to alert against unsafe practices.

**NOTE:** Indicates a situation or action that can lead to damage to your snowplow and vehicle or other property. Other useful information can also be described.

---

## WARNING/CAUTION & INSTRUCTION LABELS

Become familiar with and inform users about the warning/caution and serial number labels on the back of the blade and the instruction label on the headgear.

---

**NOTE:** If labels are missing or cannot be read, see your sales outlet.

---

# SAFETY

## Instruction Labels

**ATTACH**

1. **Pin Release Handle** to pull out **Connecting Pins**.
2. Drive vehicle slowly to engage **Pushplates** into **Attachment Arms**.
3. Attach all electrical connectors. With ignition in "ON" position, turn ON control and place in **LowerFloat**.

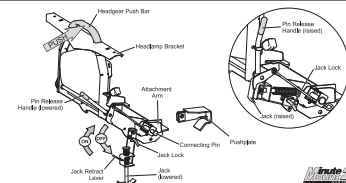

**11 J.F. SERIES INSTRUCTIONS**

Read Owner's Manual for complete instructions.

1. Place control in **LowerFloat** to put blade down.
2. Pull **Jack Lock** out, rotate **Jack** into "lower" position and engage **Jack Lock**.
3. Push down on **Jack** until it hits the ground.
4. Stand in front of blade. While pushing the **Headgear Push Bar** toward the vehicle with left hand, pull **Pin Release Handle** to disengage **Connecting Pins**. Make sure **Connecting Pins** are fully retracted.
5. Detach all electrical connectors.

**DETACH**

U.S. patents 6,353,632; 6,420,480; 6,636,616; 6,899,007; 6,263,470; 6,408,548; 6,844,976; 7,400,050; 7,430,827; 7,681,304; 7,737,576; 7,797,606; CAN. patents 2,990,425; 2,934,922; 2,329,763; 2,395,056; and other patents pending.

**ATTACH**

1. **Pin Release Handle** to pull out **Connecting Pins**.
2. Drive vehicle slowly to engage **Pushplates** into **Attachment Arms**.
3. Attach all electrical connectors. With ignition in "ON" position, turn ON control and place in **LowerFloat**.

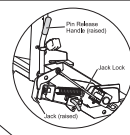

**DETACH**

1. Place control in **LowerFloat** to put blade down.
2. Pull **Jack Lock** out, rotate **Jack** into "lower" position and engage **Jack Lock**.
3. Push down on **Jack** until it hits the ground.
4. Stand in front of blade. While pushing the **Headgear Push Bar** toward the vehicle with left hand, pull **Pin Release Handle** to disengage **Connecting Pins**. Make sure **Connecting Pins** are fully retracted.
5. Detach all electrical connectors.

**DETACH**

U.S. patents 6,353,632; 6,420,480; 6,636,616; 6,899,007; 6,263,470; 6,408,548; 6,844,976; 7,400,050; 7,430,827; 7,681,304; 7,737,576; 7,797,606; CAN. patents 2,990,425; 2,934,922; 2,329,763; 2,395,056; and other patents pending.

## OR

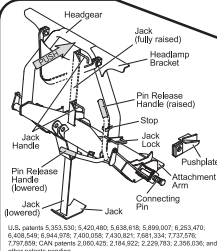

**ATTACH**

1. Push **Pin Release Handle** down to pull out **Connecting Pins**.
2. Drive vehicle slowly to engage **Pushplates** into **Attachment Arms**.
3. Stand in front of blade. Fully raise **Pin Release Handle** to release **Connecting Pins**.
4. Push **Headgear** toward vehicle to allow **Connecting Pins** to fully engage **Pushplates**. If unable to push **Headgear** in front of blade, stand in front of **Headgear** on driver side and push **Headlamp Bracket**.
5. Pull out **Jack Lock**, Push **Pin Release Handle** into **Stop**.
6. While holding **Jack Lock** out, use **Jack Handle** to raise **Jack** fully. Release **Jack Lock**.
7. Attach all electrical connectors.

**DETACH**

U.S. patents 6,353,632; 6,420,480; 6,636,616; 6,899,007; 6,263,470; 6,408,548; 6,844,976; 7,400,050; 7,430,827; 7,681,304; 7,737,576; 7,797,606; CAN. patents 2,990,425; 2,934,922; 2,329,763; 2,395,056; and other patents pending.

Read Owner's Manual for complete instructions.

1. Place control in **LowerFloat** to put blade down.
2. Pull and hold **Jack Lock** out. **Jack** will drop to ground. Then pull **Pin Release Handle** away from **Stop** and **Jack Lock**. Release **Jack Lock**. Verify **Jack** is locked by trying to lift **Jack**.
3. Stand in front of blade. While pushing **Headgear** toward vehicle with left hand, push **Pin Release Handle** down to disengage **Connecting Pins**. Make sure **Connecting Pins** are fully retracted. If unable to push **Headgear** in front of blade, stand in front of **Headgear** on driver side and push **Headlamp Bracket**.
4. Detach all electrical connectors.

**DETACH**

**ATTACH**

1. Push **Pin Release Handle** down to pull out **Connecting Pins**.
2. Drive vehicle slowly to engage **Pushplates** into **Attachment Arms**.
3. Stand in front of blade. Fully raise **Pin Release Handle** to release **Connecting Pins**.
4. Push **Headgear** toward vehicle to allow **Connecting Pins** to fully engage **Pushplates**. If unable to push **Headgear** in front of blade, stand in front of **Headgear** on driver side and push **Headlamp Bracket**.
5. Pull out **Jack Lock**, Push **Pin Release Handle** into **Stop**.
6. While holding **Jack Lock** out, use **Jack Handle** to raise **Jack** fully. Release **Jack Lock**.
7. Attach all electrical connectors.

**DETACH**

1. Place control in **LowerFloat** to put blade down.
2. Pull and hold **Jack Lock** out. **Jack** will drop to ground. Then pull **Pin Release Handle** away from **Stop** and **Jack Lock**. Release **Jack Lock**. Verify **Jack** is locked by trying to lift **Jack**.
3. Stand in front of blade. While pushing **Headgear** toward vehicle with left hand, push **Pin Release Handle** down to disengage **Connecting Pins**. Make sure **Connecting Pins** are fully retracted. If unable to push **Headgear** in front of blade, stand in front of **Headgear** on driver side and push **Headlamp Bracket**.
4. Detach all electrical connectors.

**DETACH**

## Warning/Caution Label

**WARNING**



Lower blade when vehicle is parked.



Do not exceed GVWR or GAWR including blade and ballast.

---

**CAUTION**



Read Owner's Manual before operating or servicing snowplow.



Transport speed should not exceed 45 mph (72 km/h). Further reduce speed under adverse travel conditions.



Plowing speed should not exceed 10 mph (16 km/h).

See your sales outlet/Web site for specific vehicle application recommendations.

## Multiple Pinch Points Label

**WARNING**



**Multiple Pinch Points**

## XLS™ Blades Only (both sides)



# SAFETY

## Serial Number Label

**ZZZZZ**



**YYMMDDLXXXXZZZZZ**

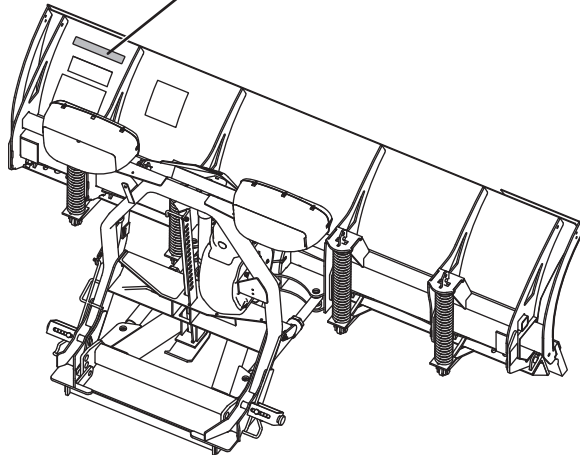

Code	Definition
YY	2-Digit Year
MM	2-Digit Month
DD	2-Digit Day
LL	2-Digit Location Code
XXXX	4-Digit Sequential Number
ZZZZZZ	5- or 6- Digit Blade Assembly PN

# SAFETY

## SAFETY PRECAUTIONS

Improper installation and operation could cause personal injury, and/or equipment and property damage. Read and understand labels and the Owner's Manual before installing, operating or making adjustments.

### WARNING

Lower blade when vehicle is parked. Temperature changes could change hydraulic pressure, causing the blade to drop unexpectedly or damaging hydraulic components. Failure to do this could result in serious personal injury.

### WARNING



Do not exceed GVWR or GAWR including the blade and ballast. The rating label is found on the driver-side vehicle door cornerpost.

### WARNING

Remove blade assembly before placing vehicle on hoist.

### CAUTION

Read Owner's Manual before operating or servicing snowplow.

### CAUTION

Transport speed should not exceed 45 mph (72 km/h). Further reduce speed under adverse travel conditions.

### CAUTION

Plowing speed should not exceed 10 mph (16 km/h).

### CAUTION

See your FISHER® outlet for application recommendations.

# SAFETY

## HYDRAULIC SAFETY

### WARNING



**Hydraulic fluid under pressure can cause skin injection injury. If you are injured by hydraulic fluid, get medical attention immediately.**

- Always inspect hydraulic components and hoses before using. Replace any damaged or worn parts immediately.
- If you suspect a hose leak, **DO NOT** use your hand to locate it. Use a piece of cardboard or wood.

## FUSES

The FISHER® electrical and hydraulic systems contain several automotive blade-style fuses. If a problem should occur and fuse replacement is necessary, the replacement fuse must be of the same type and amperage rating as the

original. Installing a fuse with a higher rating can damage the system and could start a fire. Fuse Replacement, including fuse ratings and locations, is located in the Maintenance section of this Owner's Manual.

## PERSONAL SAFETY

- Remove ignition key and put the vehicle in park or in gear to prevent others from starting the vehicle during installation or service.
- Wear only snug-fitting clothing while working on your vehicle or snowplow.
- Do not wear jewelry or a necktie, and secure long hair.
- Wear safety goggles to protect your eyes from battery acid, gasoline, dirt and dust.
- Avoid touching hot surfaces such as the engine, radiator, hoses and exhaust pipes.
- Always have a fire extinguisher rated BC handy, for flammable liquids and electrical fires.

# SAFETY

---

## FIRE AND EXPLOSION

### WARNING

**Gasoline is highly flammable and gasoline vapor is explosive. Never smoke while working on vehicle. Keep all open flames away from gasoline tank and lines. Wipe up any spilled gasoline immediately.**

Be careful when using gasoline. Do not use gasoline to clean parts. Store only in approved containers away from sources of heat or flame.

## CELL PHONES

A driver's first responsibility is the safe operation of the vehicle. The most important thing you can do to prevent a crash is to avoid distractions and pay attention to the road. Wait until it is safe to operate Mobile Communication Equipment such as cell phones, text messaging devices, pagers or two-way radios.

## VENTILATION

### WARNING

**Vehicle exhaust contains lethal fumes. Breathing these fumes, even in low concentrations, can cause death. Never operate a vehicle in an enclosed area without venting exhaust to the outside.**

# SAFETY

---

## BATTERY SAFETY

### CAUTION

**Batteries normally produce explosive gases, which can cause personal injury. Therefore, do not allow flames, sparks or lit tobacco to come near the battery. When charging or working near a battery, always cover your face and protect your eyes, and also provide ventilation.**

- **Batteries contain sulfuric acid, which burns skin, eyes and clothing.**
- **Disconnect the battery before removing or replacing any electrical components.**

## NOISE

Airborne noise emission during use is below 70 dB(A) for the snowplow operator.

## VIBRATION

Operating snowplow vibration does not exceed 2.5 m/s<sup>2</sup> to the hand-arm or 0.5 m/s<sup>2</sup> to the whole body.

# VEHICLE APPLICATION INFORMATION

---

## CAUTION

**See your FISHER® outlet/Web site for specific vehicle application recommendations before installation. The Kit Selection Guide has specific vehicle and snowplow requirements.**

Vehicle application recommendations are based on the following:

- The vehicle with the snowplow installed must comply with applicable Federal Motor Vehicle Safety Standards (FMVSS).
- The vehicle with the snowplow installed must comply with the vehicle manufacturer's stated gross vehicle and axle weight ratings (found on the driver-side door cornerpost of the vehicle) and the front and rear weight distribution ratio. In some cases, rear ballast may be required to comply with these requirements. See "Ballast Requirements" in this section.
- FISHER Kit Selection Guide/eMatch is based on available vehicle capacity for snowplow equipment on a representative vehicle equipped with options commonly used for plowing and with 300 lb of front seat occupant weight.
- Weights of front seat occupants can be adjusted above 300 lb but vehicle with snowplow must not exceed vehicle GVWR or GAWR.
- In some cases there may be additional limitations and requirements.
- Installation, modification and addition of accessories must comply with published FISHER recommendations and instructions. Available capacity decreases as the vehicle is loaded with cargo or other truck equipment, or snowplow accessories are installed.
- If there is uncertainty as to whether available capacity exists, the actual vehicle as configured must be weighed.

# VEHICLE APPLICATION INFORMATION

---

## BALLAST REQUIREMENTS

Ballast (additional weight) is an important part of qualifying vehicles for snowplow eligibility. Rear ballast must be used when necessary to remain in compliance with axle ratings and ratios as specified by the vehicle manufacturer.

If ballast is required, it is important that it be secured properly behind the rear axle. A ballast retainer kit is available from your FISHER® outlet (PN 62849).

---

**NOTE: The ballast retainer kit is for snowplow vehicles requiring ballast. See your FISHER outlet for the correct amount of ballast required. Include the weight of the retainer as part of the ballast requirement. Sand bags are recommended for use as ballast.**

---

---

**NOTE: Ballast recommended and its weight calculations assume the entire width of the bed is filled as close to tailgate as possible.**

---

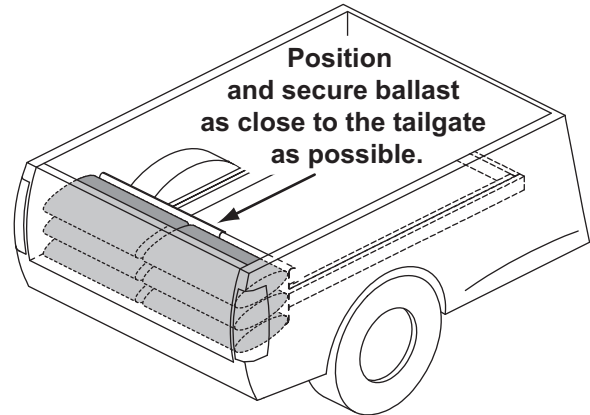

# GETTING TO KNOW YOUR SNOWPLOW

## Minute Mount® 2 SYSTEM

The Minute Mount 2 system from Fisher Engineering continues to set the industry standard for detachable snowplow design. *The quickest and easiest mounting system available, the Minute Mount 2 system is twice the mount because it takes half the time.* The Minute Mount 2 system should be installed according to the instructions supplied. FISHER® outlets are trained to perform this and other services for your snowplow.

Most of the snowplow mount can now be removed easily from the truck when it's not being used for plowing. By removing the headgear, lift arm and headlamps every time you remove the snowplow, you eliminate over 100 lb of weight on the front suspension and tires resulting in less wear all year long! This also means improved appearance of your four-wheel-drive or sport-utility vehicle.

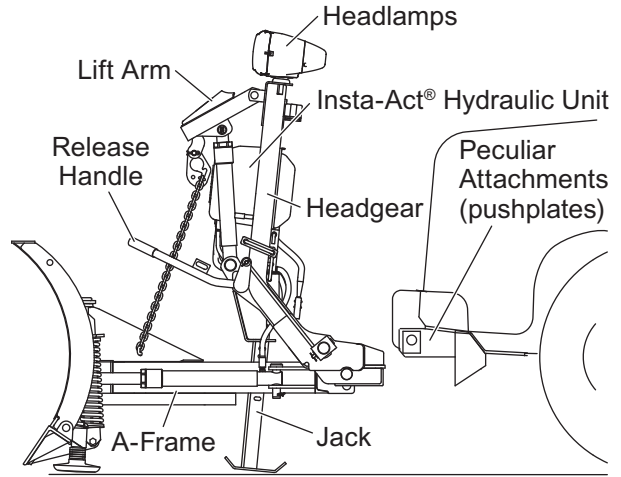



# GETTING TO KNOW YOUR SNOWPLOW

---

## BLADES

The FISHER® difference, the integral trip-edge design, is incorporated into all Minute Mount® 2 system blades. When the blade strikes an obstacle, only the edge trips, not the entire blade. When the obstacle is cleared, the edge returns to its normal plowing position. The plowed snow stays in front of the vehicle at all times because the blade remains upright.

Moldboards are constructed of STORM GUARD™ powder-coated heavy gauge steel, stainless steel or polyethylene (depending on blade model) with a formed top edge. The blades are reinforced with a steel framework to increase rigidity and strength, and are designed using the latest advances in computer design techniques.

The blade is curved to pick up snow and cast it aside smoothly—rolling snow instead of pushing it. This action allows you to move more snow faster,

using less power, saving fuel and reducing wear and tear on the vehicle and snowplow.

The base angle is designed with a unique trip edge. Each end of the trip edge is backed with a hardened steel wear bar welded behind the base angle. Heavy compression springs on the back side of the blade hold each edge in the plowing position. The springs are a safety device that allow the trip edge to ride over obstacles without damaging the blade, vehicle or injuring the driver. The springs need no adjustments and offer protection in all blade configurations and angles.

## HT Series™ Blade

The 7-1/2' HT Series snowplow is a full-sized, full-featured snowplow designed specifically for today's 1/2-ton four-wheel-drive trucks. As truck manufacturers reduce vehicle weight to increase fuel efficiency, plowers struggle to find a legitimate, rugged, hard-working snowplow that

# GETTING TO KNOW YOUR SNOWPLOW

---

matches their 1/2-ton truck specifications. The HT Series™ snowplow is the answer. Carbon steel cutting edges (3/8" & 1/2"), 1" poly cutting edge, rubber deflector, poly SnoFoil® assembly, curb guards and cast iron shoes are sold separately.

## **SD Series**

Available in 6'-9" and 7-1/2' widths, the FISHER® SD series snowplows are designed for compact and light 1/2-ton four-wheel-drive trucks, as well as some sport-utility vehicles. These snowplows are ideal for homeowners and noncommercial plowing situations.

## **HD Series**

These popular 7-1/2', 8', 8-1/2' and 9' snowplows are the choice of the plowing professional. Built for the business of plowing, these rugged snowplows will withstand the rigors of any and all commercial applications. The HD series is designed for midsize and 1/2-ton four-wheel-drive

trucks, full-size sport-utility vehicles, 3/4-ton and 1-ton 4x4 trucks, as well as today's new "Super-Duty" vehicles. Carbon steel cutting edge, SnoFoil assembly and deflectors (steel and rubber) are sold separately.

## **XBLADE™ Series**

Available in 8' and 9' widths, the XBLADE series snowplow is the choice of the extreme-duty plowing professional. The moldboard is available in stainless steel. Designed for 3/4- and 1-ton 4x4 trucks, as well as today's new "Super-Duty" vehicles, these extreme-duty rated snowplows are the ultimate snowplow for all heavy commercial applications. Carbon steel reversible cutting edge, rubber deflectors and wear/curb shoe kits sold separately.

# GETTING TO KNOW YOUR SNOWPLOW

---

## MC Series

Designed for trucks in the 17,000–27,500 GVW range, these FISHER® 9' and 10' snowplows are now available with the Minute Mount® 2 system. Built for municipalities and contractors who need to clear parking lots, narrow streets and intersections, both blades include a trip-edge design, 8" center-punched reversible cutting edge, 2" x 10" lift ram and 2" x 16" angle rams. SnoFoil® assembly and rubber deflector are sold separately.

## XtremeV™ Series

The XtremeV snowplow features the popular XBLADE™ frame construction and a tapered wing design to provide a multiposition snowplow with superior torsional strength in 7-1/2', 8-1/2' and 9-1/2' widths. The formed cutting edge eliminates snow passing through and being left behind. The moldboard is available in either stainless or

STORM GUARD™ powder-coated steel. Cutting edge is standard. Available accessories include a rubber deflector, blade wing extensions and a back drag edge.

## XLS™ Series

From an 8' retracted to a 10' expanded straight-blade, to a scoop width of nearly 9', the XLS snowplow delivers a new level of versatility and performance. Its wide scoop position carries more snow and can fully angle to maximize handling and capacity when cornering or plowing around obstacles. For unmatched windrowing productivity, the leading wing angles forward to direct more snow into the moldboard to minimize spilloff and effectively use the entire blade width.

# GETTING TO KNOW YOUR SNOWPLOW

---

## A-FRAME/T-FRAME

### **Straight Blade & HT Series™ A-Frame**

The A-frame is attached to the blade assembly with a centered pivot pin (HT Series A-frames use a center screw). The pivot pin allows the blade assembly to angle left or right 28°, providing excellent snow displacement. The heavy 1" pivot pin is shear-proof under normal operation, assuring a solid connection.

### **XLS™ A-Frame**

The A-frame is attached to the blade assembly with a centered pivot pin. The pivot pin allows the blade assembly to angle left or right 25°, providing excellent snow displacement. The heavy 1" pivot pin is shear-proof under normal operation, assuring a solid connection.

### **XtremeV™ T-Frame/Push Assembly**

The T-frame is designed with a connecting assembly that provides optimum strength to weight ratio and adjustment for variations in vehicle height. The feature ensures that blade edges can be parallel to the road surface when plowing. The diagonal brace holds the top of the hinge pin and the blade vertical.

## **HEADGEAR**

The headgear assembly is composed of the headgear, linkage mechanism, lift arm and jack. The headgear is connected to the pushplates, which are mounted directly to the vehicle frame. The headgear also provides the mounting framework for the FISHER® Insta-Act® hydraulic unit and the lift arm. The lift ram raises and lowers the blade by moving the lift arm and lift chain. The jack, when lowered, supports the snowplow during and after its removal from the vehicle.

# GETTING TO KNOW YOUR SNOWPLOW

<b>Weights: Off-Truck Assembly with Blade</b>			
<b>Size</b>	<b>Blade Assembly</b>	<b>Wt (lb)</b>	<b>Wt (kg)</b>
7-1/2'	HT Series™ Snowplow (MS)	414	188
6'-9"	SD Snowplow (MS)	472	214
7-1/2'	SD Snowplow (MS)	487	221
7-1/2'	HD Snowplow (MS)	637	289
8'	HD Snowplow (MS)	717	325
8-1/2'	HD Snowplow (MS)	731	332
9'	HD Snowplow (MS)	745	338
7-1/2'	XBLADE™ Snowplow (SS)	742	337
8'	XBLADE Snowplow (SS)	790	358
8'	XBLADE Snowplow (Poly)	721	327
8-1/2'	XBLADE Snowplow (SS)	813	369
9'	XBLADE Snowplow (SS)	835	379
9'	XBLADE Snowplow (Poly)	757	343
7-1/2'	XtremeV™ Snowplow	849	385
8-1/2'	XtremeV Snowplow	899	408
9-1/2'	XtremeV Snowplow	1013	459
8'-10'	XLS™ Snowplow	985	447
9'	MC Snowplow (MS)	1174	533
10'	MC Snowplow (MS)	1308	593

# GETTING TO KNOW YOUR SNOWPLOW

---

## MOUNT KITS

Fisher Engineering has designed a mount kit for most vehicles. Due to the differences between vehicle models, the kits are not interchangeable.

The mount kit fastens to the vehicle frame. It is engineered to provide the primary connecting points between the snowplow assembly and the vehicle. The weight of the Minute Mount® 2 system is distributed to the frame of your vehicle by the pushplates.

## INTENSIFIRE™ SNOWPLOW HEADLAMPS

### **WARNING**

**Your vehicle must be equipped with snowplow headlamps and directional lights.**

The snowplow headlamps include a set of INTENSIFIRE dual-beam halogen headlamps with combination park and turn signals. A prewired harness with a plug-in module requires no headlamp wire splicing. The headlamps conform to Federal Motor Vehicle Safety Standards (FMVSS).

When the electrical plugs are connected, the vehicle headlamps will automatically switch to the snowplow headlamps when they are turned ON. When the electrical plugs are disconnected, the headlamps will automatically switch to vehicle headlamps when they are turned ON.

Replacement parts are available through your local FISHER® outlet.

# GETTING TO KNOW YOUR SNOWPLOW

## Insta-Act® HYDRAULIC UNITS

The Insta-Act hydraulic unit delivers fast and uniform speed for lifting and angling. Straight blades are raised in approximately 3 seconds and angled side to side in approximately 6 seconds.

### Straight Blades

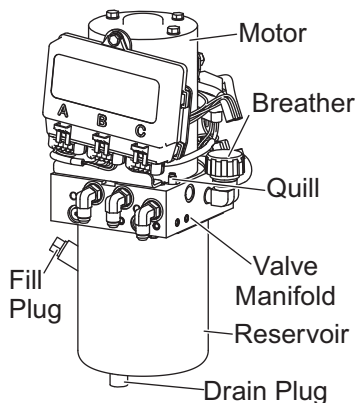

The HT Series™ hydraulic unit has blade scrape lock circuitry built into it. This feature resists the tendency a snowplow has to "float up" as larger amounts of snow build up in front of it while plowing deep snow, or stacking snow into piles. This feature is activated when the blade is in FLOAT, and is factory set. See your sales outlet for adjustment. The HT Series blade is raised in approximately 4 seconds and angled side to side in approximately 3 seconds.

### HT Series Blades

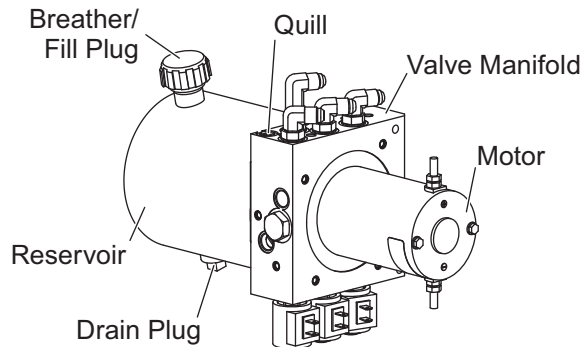

# GETTING TO KNOW YOUR SNOWPLOW

The XtremeV™ blade is raised in approximately 2 seconds and angled side to side in approximately 2 seconds.

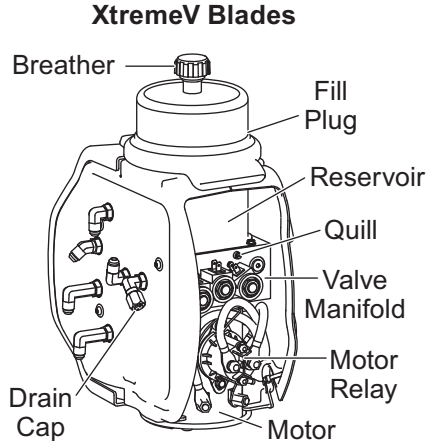

The XLS™ blade is raised in approximately 2 seconds and angled side to side in approximately 2 seconds. Each wing extends and retracts individually in approximately 2 seconds.

Both wings extend together in 4 seconds and retract together in 3 seconds.

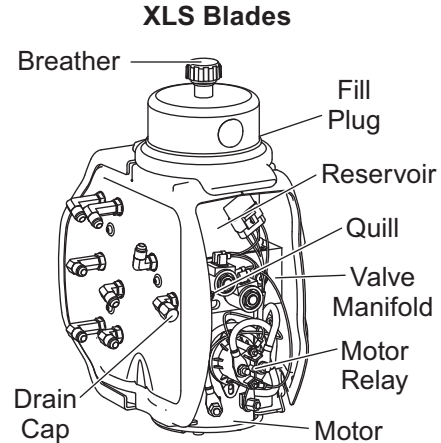

The Insta-Act® hydraulic unit's angling gives you full control of the snowplow from within the cab. Hydraulic rams hold the blade at a desired angle. In XtremeV and XLS blades, the rams operate each wing independently or as a single unit.



# GETTING TO KNOW YOUR SNOWPLOW

## System Capacity

- Insta-Act® Unit Reservoir ..... 1-3/4 quarts
- Insta-Act System Total ..... 2-3/8 to 2-3/4 quarts

## Pump Motor Specifications

### Straight Blades

12-volt DC with +/- Connection
1700–1800 psi Pump Relief Valve
4000 psi Angling Relief Valve
4.5" dia 1.5 kW Motor
0.000477 gal/rev Pump
Hydraulic Hose 1/4 SAE 100R1 and 3/8 SAE 100R17

### HT Series™ Blades

12-volt DC with +/- Connection
1600–1700 psi Pump Relief Valve
4000 psi Angling Relief Valve
3" dia 0.8 kW Motor
0.000477 gal/rev Pump
Hydraulic Hose SAE 100R1

### XtremeV™ Blades

12-volt DC with +/- Connection
2200–2300 psi Pump Relief Valve
4550–4650 psi Plowing Relief Valve
3650–3750 psi Back Dragging Relief Valve
4.5" dia 1.5 kW Motor
0.000652 gal/rev Pump
Hydraulic Hose 1/4 SAE 100R1 and 3/8 SAE 100R17

### XLS™ Blades

12-volt DC with +/- Connection
2200–2300 psi Pump Relief Valve
4000 psi Plowing Relief Valve
1500 & 1700 psi Wing Plowing Relief Valves
4.5" dia 1.5 kW Motor
0.000652 gal/rev Pump
Hydraulic Hose 1/4 SAE 100R1 and 3/8 SAE 100R17

# GETTING TO KNOW YOUR SNOWPLOW

---

## CAB CONTROLS

### **WARNING**

**To prevent accidental movement of the blade, always turn the control OFF whenever the snowplow is not in use. The power indicator light will turn OFF.**

FISHER® snowplows come equipped with one of two special controls: the Fish-Stik® hand-held control or a joystick-style control.

The XtremeV™ snowplow controls allow you to go from a V-plow, to a scoop, to a standard straight-blade snowplow, all at the touch of a button or single-lever movement.

The XLS™ snowplow controls allow you to go from an extra wide snowplow, to a scoop, to a standard straight-blade snowplow, all at the touch of a button.

Each control has its own ON/OFF switch with an indicator light to show when the control is powered up. Your vehicle ignition (key) switch controls a fused circuit that powers your cab control directly from the battery.

The ON/OFF switch on the cab control allows you to turn OFF the control and prevent blade movement even when the ignition switch is ON.

**The control ON/OFF switch serves as an emergency stop if required.**

All controls are protected by a replaceable fuse located in the under hood snowplow electrical system. See "Fuse Replacement" in the Maintenance section of this Owner's Manual.

## Straight Blade Controls with FLEET FLEX System

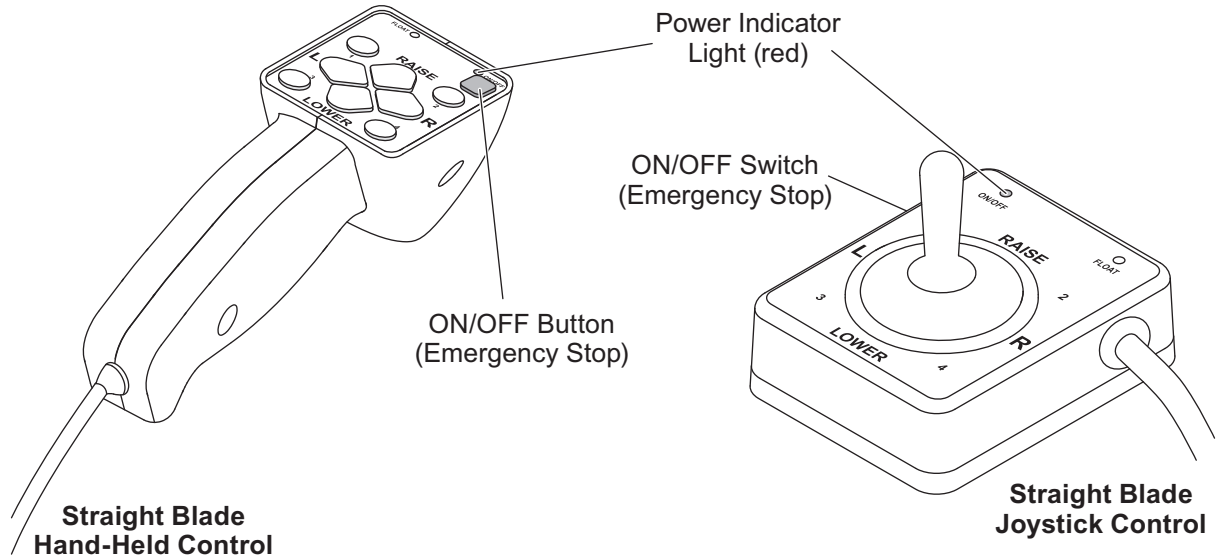

# GETTING TO KNOW YOUR SNOWPLOW

## XtremeV™ & XLS™ Snowplow Controls with FLEET FLEX System

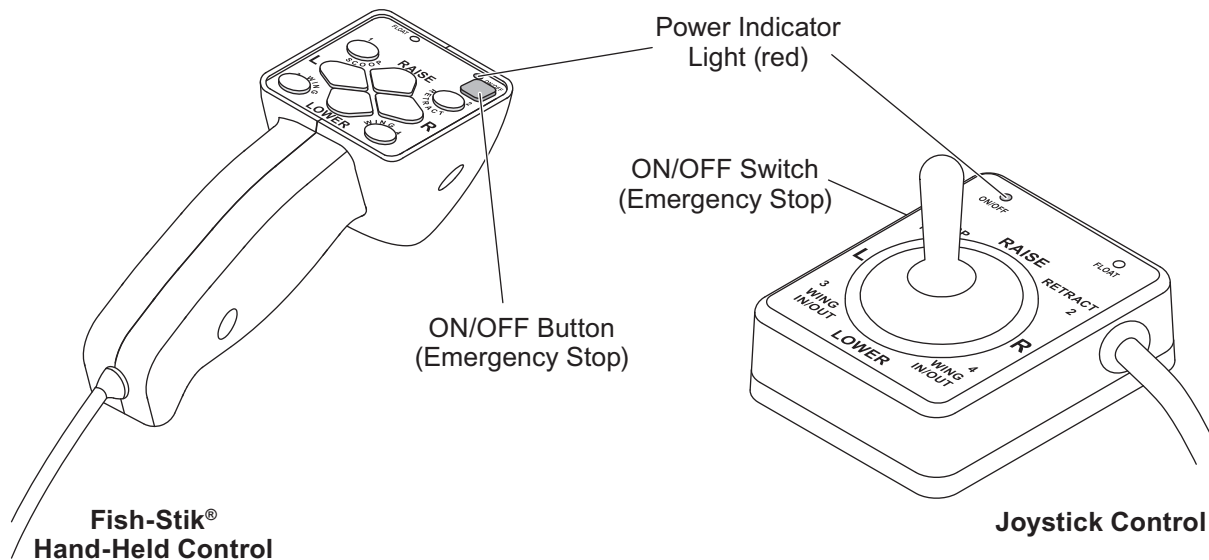

## ACCESSORIES AND OPTIONS

---



### SnoFoil® ASSEMBLY

A rigid curved extension attached to the top of your snowplow blade deflects light snow away from the windshield. It improves your plowing visibility and efficiency. The SnoFoil assembly bolts onto your existing blade and is available for 7-1/2', 8', 8-1/2', 9' and 10' straight blades.

### STEEL DEFLECTOR

Keeps fluffy snow from flowing over the top of the blade. It fits FISHER® SD and HD series blades. Easily installed and attractively priced.

### RUBBER DEFLECTOR

Attaches to HT Series™, SD, HD, XBLADE™, MC, XtremeV™ and XLS™ series blades. The flexible deflector keeps fluffy snow from flowing over the top of the blade. Easily installed and attractively priced.

### REPLACEABLE CARBON STEEL CUTTING EDGE

These cutting edges are made of high carbon steel and bolt onto the base angle for maximum blade life. Steel cutting edges are available for HT Series, SD, HD, XBLADE, MC, XtremeV and XLS series blades. Depending on the blade series, cutting edges are 3/8" or 1/2" thick, and 6" or 8" wide.

# ACCESSORIES AND OPTIONS

---

## REPLACEABLE POLYMER CUTTING EDGE

The 1"-thick cutting edges are made of durable polymer. They are lightweight and absorb most of the shock and vibration when the blade encounters rough surfaces. Designed for our HT Series™ and SD series blades, they are available in 6'-9" (SD series only) and 7'-6" lengths.

## FISHER® EZ Flow HYDRAULIC FLUID

Improve the performance of your hydraulic systems, especially in extremely cold weather, with FISHER EZ Flow hydraulic fluid. Special antiwear and antifoaming additives keep your system running longer and smoother.

## ANTIWEAR SHOES

For use where surfaces are rocky and/or abrasive (hard pack, gravel), antiwear shoes offer

maximum protection against blade and/or base angle wear. Available for the HT Series, SD series, XtremeV™ and XLS™ snowplows.

## WEAR/CURB SHOE KIT

Available for the XBLADE™ series only, these shoes offer two different types of wear protection. The flat bottom section protects the cutting edge surface from wear against rough surfaces. A radial edge that extends beyond the edge of the snowplow also protects the ends of the bottom trip edge from wear scraping against curbing and sidewalks.

## CURB GUARD KIT

Designed to fit on the ends of the trip edge, these guards protect against scraping the bottom edge of the blade against curbs and sidewalks. The kit is available for 7-1/2', 8', 8-1/2' and 9' SD, HD and XBLADE series straight blades and all HT Series and XtremeV blades.

# ACCESSORIES AND OPTIONS

---

## TOUCH-UP PAINT

FISHER® touch-up paint is available to keep your snowplow protected from rust.

## Minute Mount® 2 SYSTEM SKID PLATES

These off-season inserts for the Minute Mount 2 system pushplates offer protection by filling and covering the receiver portion of the pushplates. They also add to the vehicle's off-season appearance.

## ProTube™ BUMPER/GRILLE GUARD

Available in polished 304-grade stainless steel or black powder-coated finish, this attractive, off-season grille guard mounts to existing Minute Mount 2 system pushplates. The mounting brackets double as skid plates. Tabs are included for mounting auxiliary fog lights (not included).

## PLOW PARKA

This plow cover is constructed of heavy duty nylon and includes a gathered elastic band sewn into the bottom edge for a tight, weather-resistant fit. This long lasting cover takes just seconds to install and provides protection for your snowplow's electrical and hydraulic systems.

## DIELECTRIC GREASE

Specially formulated to protect all your electrical connections in severe winter conditions, Fisher Engineering recommends all snowplow owners use dielectric grease on a regular basis.

## EMERGENCY PARTS TOOL BOX KIT

This tool box contains necessary service parts to make many repairs to your snowplow, on the spot. Along with these parts, the kit contains a knit cap to keep your ears warm while out in the cold and also a quart of FISHER EZ Flow hydraulic fluid.

# ATTACHING SNOWPLOW TO VEHICLE

---

---

## ATTACHING SNOWPLOW

### WARNING

Keep 8' clear of the blade drop zone when it is being raised, lowered or angled. Do not stand between the vehicle and blade or directly in front of blade. If the blade hits you or drops on you, you could be seriously injured.

### WARNING

Inspect snowplow components and bolts for wear or damage whenever attaching or detaching the snowplow. Worn or damaged components could allow the snowplow to drop unexpectedly.

---

**NOTE:** The blade must be in the straight position when attaching or detaching the snowplow.

---

---

**NOTE:** Use dielectric grease to prevent corrosion on all connections.

---

### Attaching Steps:

1. Pull pin release handle and push down to pull out connecting pins.
2. Drive vehicle slowly to engage pushplates into attachment arms.

**HT Series™ Blades ONLY:** Attach all electrical connectors. With the ignition in the "ON" position, turn ON the control and activate the FLOAT mode.

3. Stand in front of blade. Fully raise pin release handle to release connecting pins.



# ATTACHING SNOWPLOW TO VEHICLE

4. Push headgear toward vehicle to allow connecting pins to fully engage pushplates. If unable to push headgear from in front of blade, stand in front of headgear on driver side and push headlamp bracket.

**HT Series™ Blades:** Using headgear push bar, push headgear toward vehicle to allow connecting pins to fully engage pushplates.

5. Pull out jack lock. Push pin release handle into stop.

**HT Series Blades:** Push up on jack retract lever. Jack will raise automatically. Pull jack lock out, rotate jack into up position and engage jack lock. Stop here, attaching is complete.

6. While holding jack lock out, use jack handle to raise jack fully. Release jack lock.

7. Attach all electrical connectors.

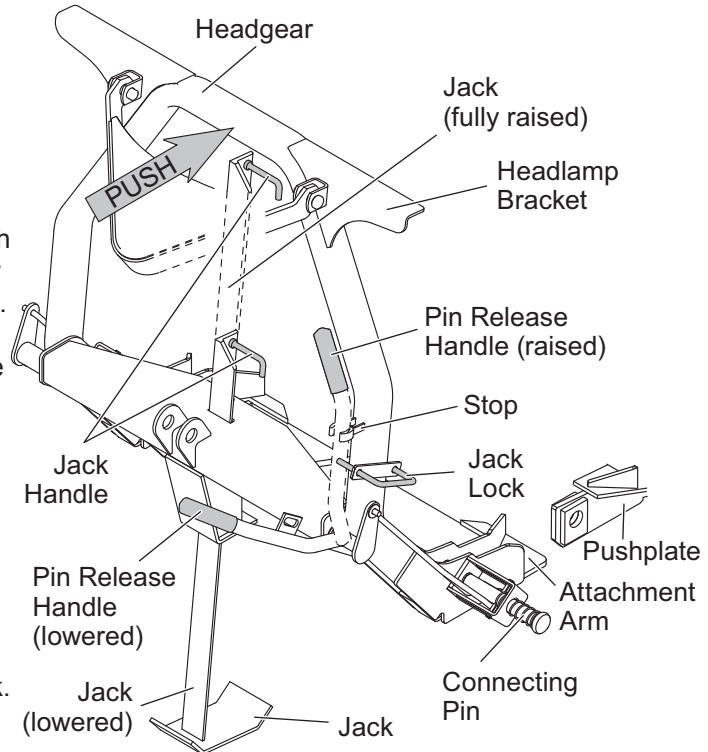

# ATTACHING SNOWPLOW TO VEHICLE

HT  
SERIES

## HT Series™ Attach/Detach Diagram

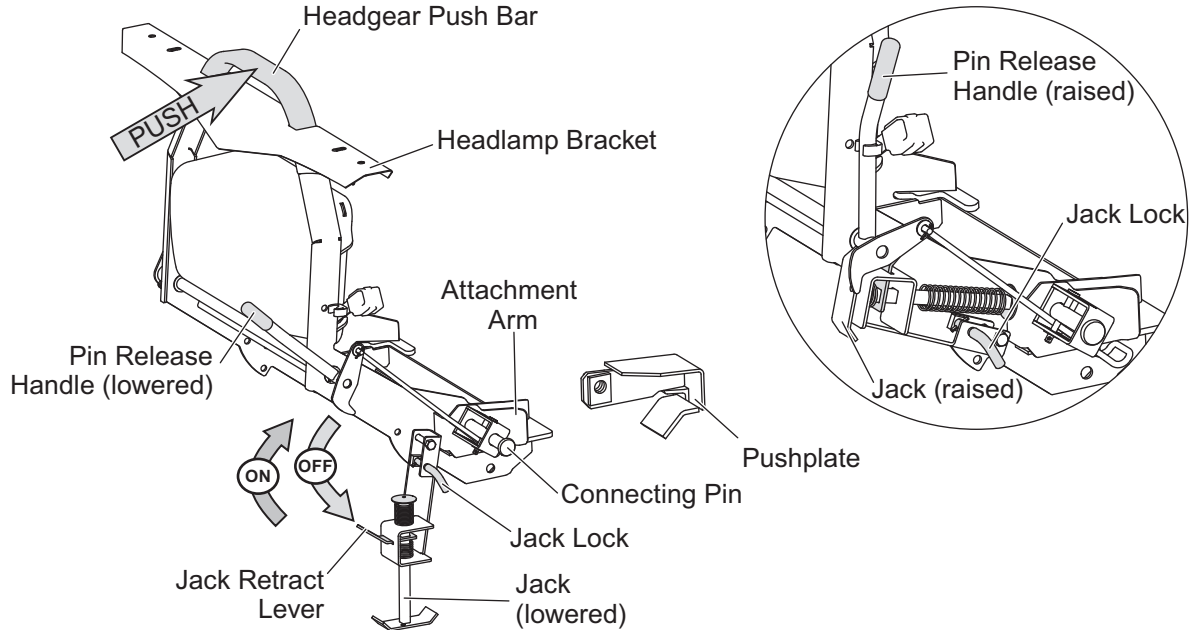

## Straight Blade Fish-Stik® HAND-HELD CONTROL

### ⚠ WARNING

To prevent accidental movement of the blade, always push the ON/OFF button to switch the control OFF whenever the snowplow is not in use. The power indicator light will turn OFF.

1. Turn the vehicle ignition switch to the "ON" or "ACCESSORY" position.
2. Press the ON/OFF button on the control. The power indicator light glows red, indicating the control is ON. The power indicator light glows red whenever the control and the vehicle ignition switch are both ON and the electrical connections to the snowplow are completed.

The ON/OFF button operates as an emergency stop if required.

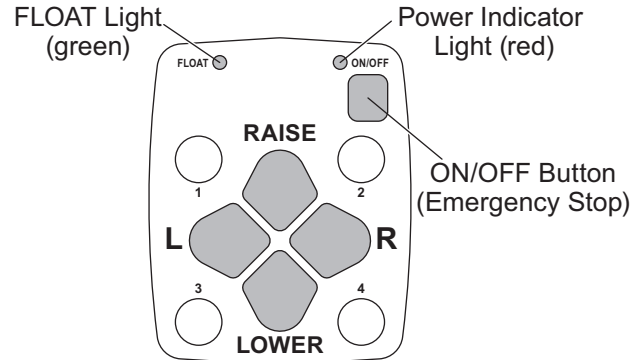

### Function Time-Outs

All control functions, except LOWER/FLOAT, time out (stop) automatically after a period of time. This is to limit the amount of electrical energy required from the vehicle.

**NOTE: If control function times out before desired blade movement is complete, release button and press again.**

## Automatic Shutdown

The control will automatically turn OFF after being idle for 20 minutes. To reactivate the control after a shutdown, press the ON/OFF button.

## Smooth Stop

The control automatically allows the blade to coast to a stop when the button is released. This results in smoother operation, reduces the shock to the hydraulic system and increases hose and valve life. See "FLEET FLEX Electrical System" in this section for more information.

## Control Functions

### Raise, Lower, Float, Angle

The four diamond-shaped buttons in the center of the control face, when pressed, will result in the blade movements described in the table.

Function	Description of Operation
<b>RAISE</b>	Press this button to raise the snowplow and cancel the FLOAT mode. Function times out after 3.5 seconds.
<b>LOWER</b>	Press this button to lower the snowplow. Release the button to stop blade at desired height.
<b>FLOAT†</b>	Press the <b>LOWER</b> button and hold 3/4 second to activate this mode. The FLOAT light in the upper left corner of the control face will illuminate. The blade will lower to the ground surface and follow the contour of the surface as it dips or raises. Function does not time out, but control will shut down after 20 minutes of nonuse. Press <b>RAISE</b> button momentarily to cancel FLOAT. Angling left or right will not interrupt (stop) the FLOAT function.

† FLOAT mode activates immediately when one-touch FLOAT feature is enabled. See "One-Touch FLOAT" in this section for more information.

Function	Description of Operation
<b>L</b> (Angle Left)	Press this button to angle the blade to the left. Function times out after 3.25 seconds.
<b>R</b> (Angle Right)	Press this button to angle the blade to the right. Function times out after 3.25 seconds.

---

**NOTE: If control function times out before desired blade movement is complete, release button and press again.**

---

## SECURITY GUARD™ System (1, 2, 3, 4)

The four round buttons located to the left and right of the LOWER and RAISE buttons will operate the SECURITY GUARD system. See "SECURITY GUARD System" in this section for more information.

## STRAIGHT BLADE JOYSTICK CONTROL

### **⚠ WARNING**

To prevent accidental movement of the blade, always move the ON/OFF switch to OFF whenever the snowplow is not in use. The power indicator light will turn OFF.

1. Turn the vehicle ignition switch to the "ON" or "ACCESSORY" position.
2. Move the ON/OFF switch on the side of the control to the "ON" position. The power indicator light glows red, indicating the control is ON. The indicator light glows red whenever the control and the vehicle ignition switch are both ON and the electrical connections to the snowplow are completed.

The ON/OFF switch operates as an emergency stop if required.

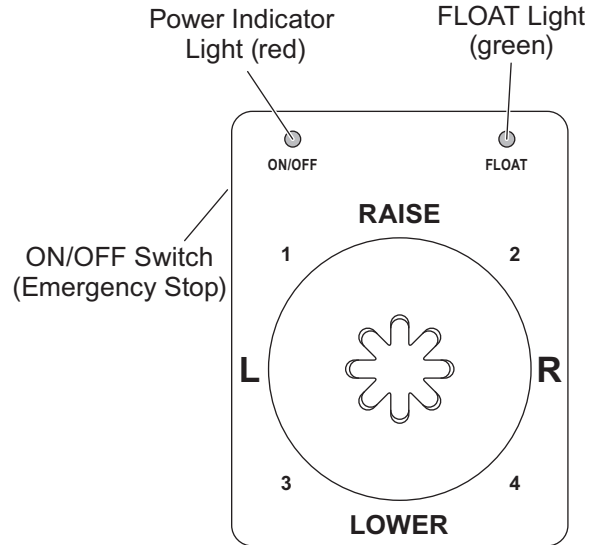

## Function Time-Outs

All control functions, except LOWER/FLOAT, time out (stop) automatically after a period of time. This is to limit the amount of electrical energy required from the vehicle.

---

**NOTE: If control function times out before desired blade movement is complete, release the lever to the center position, then move back into the desired function.**

---

## Automatic Shutdown

The control will automatically turn OFF after being idle for 20 minutes. To reactivate the control after a shutdown, move the ON/OFF switch to OFF, then back to ON.

## Smooth Stop

The control automatically allows the blade to coast to a stop when the lever returns to center position. This results in smoother operation, reduces the shock to the hydraulic system and increases hose and valve life. See "FLEET FLEX Electrical System" in this section for more information.

## Control Lever Movement

From the center position, the control lever can be moved in one of eight (8) directions to control various movements of the snowplow blade. To change from one movement of the blade to another, the control lever must be moved back to the center position before selecting the desired function. Whenever the lever is released, it should spring back into the center position to stop any blade movement.

## Control Functions

### Raise, Lower, Float, Angle

Moving the control lever in straight lines up and down or from side to side on the control body will result in the blade movements described in the following tables.

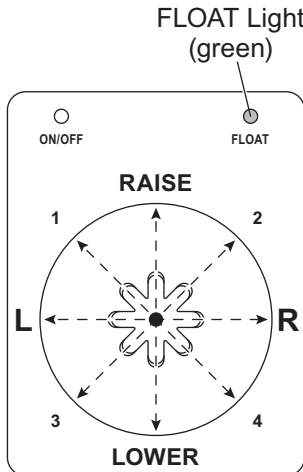

Function	Description of Operation
<b>RAISE</b>	Move the control lever toward the top of the control body to raise the snowplow and cancel the FLOAT mode. Function times out after 3.5 seconds.
<b>LOWER</b>	Move the control lever toward the bottom of the control body to lower the snowplow. Release the lever to stop blade at desired height.
<b>FLOAT†</b>	Move the control lever to the <b>LOWER</b> position and hold 3/4 second to activate this mode. The FLOAT light in the upper right corner of the control face will illuminate. The blade will lower to the ground surface and follow the contour of the surface as it dips or raises. Function does not time out; however, control will shut down after 20 minutes of nonuse.  Move lever to the <b>RAISE</b> position momentarily to cancel FLOAT. Angling left or right will not interrupt (stop) the FLOAT function.

† FLOAT mode activates immediately when one-touch FLOAT feature is enabled. See "One-Touch FLOAT" in this section for more information.



Function	Description of Operation
L (Angle Left)	Move the control lever straight to the left to angle the blade left. Function times out after 3.25 seconds.
R (Angle Right)	Move the control lever straight to the right to angle the blade right. Function times out after 3.25 seconds.

**NOTE: If control function times out before desired blade movement is complete, release the lever to the center position, then move back into the desired function.**

### SECURITY GUARD™ System (1, 2, 3, 4)

Moving the control lever from the center position toward any of the four digits on the face of the control body will operate the SECURITY GUARD system. See "SECURITY GUARD System" in this section for more information.

# OPERATING YOUR SNOWPLOW

## XtremeV™ & XLS™ Fish-Stik® HAND-HELD CONTROL

### **⚠ WARNING**

To prevent accidental movement of the blade, always push the ON/OFF button to switch the control OFF whenever the snowplow is not in use. The power indicator light will turn OFF.

1. Turn the vehicle ignition switch to the "ON" or "ACCESSORY" position.
2. Press the ON/OFF button on the control. The power indicator light glows red, indicating the control is ON. The power indicator light glows red whenever the control and the vehicle ignition switch are both ON and the electrical connections to the snowplow are completed.

The ON/OFF button operates as an emergency stop if required.

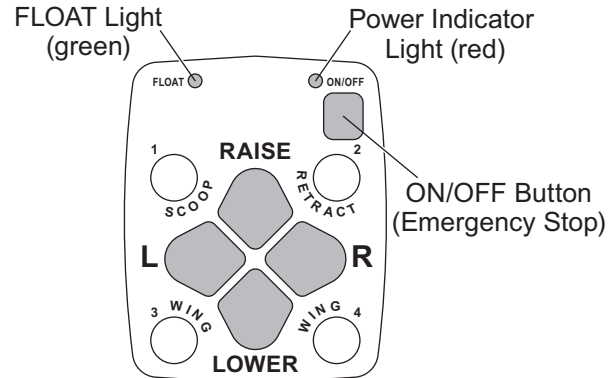

## Function Time-Outs

All control functions, except LOWER/FLOAT, time out (stop) automatically after a period of time. This is to limit the amount of electrical energy required from the vehicle.

**NOTE: If control function times out before desired blade movement is complete, release button and press again.**

# OPERATING YOUR SNOWPLOW

## Automatic Shutdown

The control will automatically turn OFF after being idle for 20 minutes. To reactivate the control after a shutdown, press the ON/OFF button.

## Smooth Stop/Soft Stop

The control automatically allows the blade to coast to a stop when the button is released. This results in smoother operation, reduces the shock to the hydraulic system and increases hose and valve life. See "FLEET FLEX Electrical System" in this section for more information.

## Control Functions

### Raise, Lower, Float, Angle

The four diamond-shaped buttons in the center of the control face, when pressed, will result in the blade movements described in the table.

Function	Description of Operation
<b>RAISE</b>	Press this button to raise the snowplow and cancel the FLOAT mode. Function times out after 3.5 seconds.
<b>LOWER</b>	Press this button to lower the snowplow. Release the button to stop blade at desired height.
<b>FLOAT†</b>	Press the <b>LOWER</b> button and hold 3/4 second to activate this mode. The FLOAT light in the upper left corner of the control face will illuminate. The blade will lower to the ground surface and follow the contour of the surface as it dips or raises. Function does not time out, but control will shut down after 20 minutes of nonuse. Press <b>RAISE</b> button momentarily to cancel FLOAT. Angling left or right will not interrupt (stop) the FLOAT function.

† FLOAT mode activates immediately when one-touch FLOAT feature is enabled. See "One-Touch FLOAT" in this section for more information.

# OPERATING YOUR SNOWPLOW

Function	Description of Operation
<b>L</b> (Angle Left)	With wings in a straight line, press the <b>L</b> button to move both wings to the angle left position to cast snow to the driver's left side. The left wing retracts while the right wing extends (XtremeV™). Function times out after 3.25 seconds.
<b>R</b> (Angle Right)	With wings in a straight line, press the <b>R</b> button to move both wings to the angle right position to cast snow to the driver's right side. The right wing retracts while the left wing extends (XtremeV). Function times out after 3.25 seconds.

**NOTE: If control function times out before desired blade movement is complete, release button and press again.**

## Scoop/Retract Blade Position XLS™ and XtremeV Blades

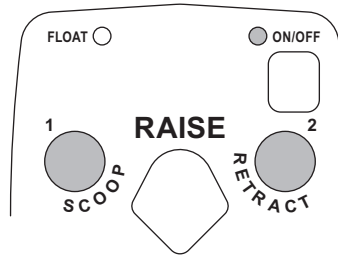

The two round buttons located to the left and right of the RAISE button move both wings at the same time into the blade positions described in the following table.

Function	Description of Operation
<b>SCOOP</b>	Press this button to extend both wings forward into the scoop position. Function times out after 5.5 seconds.
<b>RETRACT</b>	Press this button to draw both wings into the fully retracted (vee) position. Function times out after 4.5 seconds.

# OPERATING YOUR SNOWPLOW

## Wing Positions

### XLS™ and XtremeV™ Blades

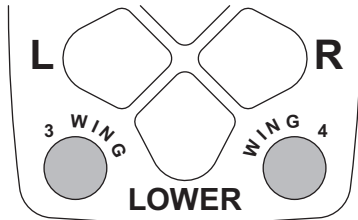

The two round buttons located to the left and right of the LOWER button move either wing independently of the other as described in the following table.

### SECURITY GUARD™ System (1, 2, 3, 4)

The four round buttons located to the left and right of the LOWER and RAISE buttons will also operate the SECURITY GUARD system (if equipped). See "SECURITY GUARD System" in this section for more information.

Function	Description of Operation
L WING	Press this button on the left side of the control to move the left wing. The first time the button is pressed after the control is turned ON or another function is used, the wing will extend. Repeated use of the same button, without using another function, results in movement in the opposite direction from the previous movement. Function times out after 3.75 (OUT) or 3.25 seconds (IN).
R WING	Press this button on the right side of the control to move the right wing. The first time the button is pressed after the control is turned ON or another function is used, the wing will extend. Repeated use of the same button, without using another function, results in movement in the opposite direction from the previous movement. Function times out after 3.75 (OUT) or 3.25 seconds (IN).

# OPERATING YOUR SNOWPLOW

## XtremeV™ & XLS™ JOYSTICK CONTROL

### **⚠ WARNING**

To prevent accidental movement of the blade, always move the ON/OFF switch to OFF whenever the snowplow is not in use. The power indicator light will turn OFF.

1. Turn the vehicle ignition switch to the "ON" or "ACCESSORY" position.
2. Move the ON/OFF switch on the side of the control to the "ON" position. The power indicator light glows red, indicating the control is ON. The indicator light glows red whenever the control and the vehicle ignition switch are both ON and the electrical connections to the snowplow are completed.

The ON/OFF switch operates as an emergency stop if required.

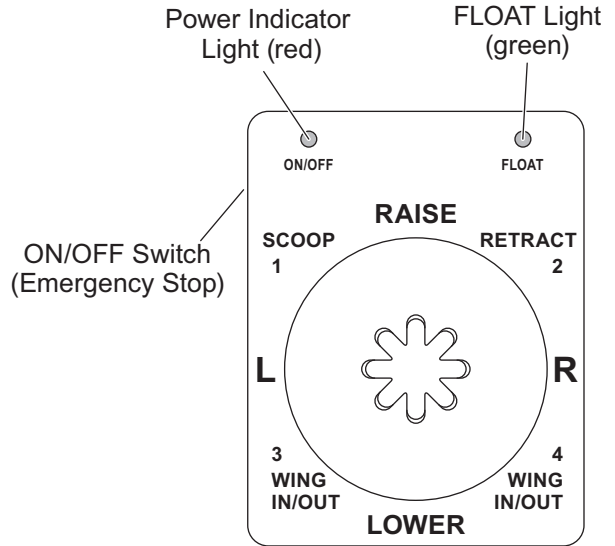

# OPERATING YOUR SNOWPLOW

---

## Function Time-Outs

All control functions, except LOWER/FLOAT, time out (stop) automatically after a period of time. This is to limit the amount of electrical energy required from the vehicle.

---

**NOTE: If control function times out before desired blade movement is complete, release the lever to the center position, then move back into the desired function.**

---

## Automatic Shutdown

The control will automatically turn OFF after being idle for 20 minutes. To reactivate the control after a shutdown, move the ON/OFF switch to OFF, then back to ON.

## Smooth Stop/Soft Stop

The control automatically allows the blade to coast to a stop when the lever returns to center position. This results in smoother operation, reduces the shock to the hydraulic system and increases hose and valve life. See "FLEET FLEX Electrical System" in this section for more information.

## Control Lever Movement

From the center position, the control lever can be moved in one of eight (8) directions to control various movements of the snowplow blade. To change from one movement of the blade to another, the control lever must be moved back to the center position before selecting the desired function. Whenever the lever is released, it should spring back into the center position to stop any blade movement.

# OPERATING YOUR SNOWPLOW

## Control Functions

### Raise, Lower, Float, Angle

Moving the control lever in straight lines up and down or from side to side on the control body will result in the blade movements described in the following tables.

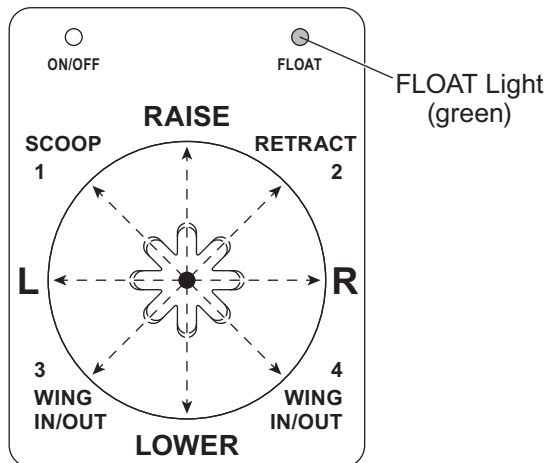

Function	Description of Operation
RAISE	Move the control lever toward the top of the control body to raise the snowplow and cancel the FLOAT mode. Function times out after 3.5 seconds.
LOWER	Move the control lever toward the bottom of the control body to lower the snowplow. Release the lever to stop blade at desired height.
FLOAT†	Move the control lever to the <b>LOWER</b> position and hold 3/4 second to activate this mode. The FLOAT light in the upper right corner of the control face will illuminate. The blade will lower to the ground surface and follow the contour of the surface as it dips or raises. Function does not time out; however, control will shut down after 20 minutes of nonuse. Move lever to the <b>RAISE</b> position momentarily to cancel FLOAT. Angling left or right will not interrupt (stop) the FLOAT function.

† FLOAT mode activates immediately when one-touch FLOAT feature is enabled. See "One-Touch FLOAT" in this section for more information.



# OPERATING YOUR SNOWPLOW

Function	Description of Operation
<b>L</b> (Angle Left)	With wings in a straight line, move the control lever straight to the left to move both wings to the angle left position to cast snow to the driver's left side. The left wing retracts while the right wing extends (XtremeV™). Function times out after 3.25 seconds.
<b>R</b> (Angle Right)	With wings in a straight line, move the control lever straight to the right to move both wings to the angle right position to cast snow to the driver's right side. The right wing retracts while the left wing extends (XtremeV). Function times out after 3.25 seconds.

**NOTE: If control function times out before desired blade movement is complete, release the lever to the center position, then move back into the desired function.**

## Scoop/Retract Blade Position XLS™ and XtremeV Blades

Moving the control lever from the center position toward the word SCOOP or RETRACT on the face of the control body will cause both wings to move at the same time into the following blade positions.

Function	Description of Operation
<b>SCOOP</b>	Move the control lever toward the word SCOOP on the control face to extend both wings forward into the scoop position. Function times out after 5.5 seconds.
<b>RETRACT</b>	Move the control lever toward the word RETRACT on the control face to draw both wings into the fully retracted (vee) position. Function times out after 4.5 seconds.

# OPERATING YOUR SNOWPLOW

## Wing Positions

### XLS™ and XtremeV™ Blades

Moving the control lever from the center position toward the words WING IN/OUT, on either side of the face of the control body will cause either wing to move independently of the other as described in the following table.

---

**NOTE: If control function times out before desired blade movement is complete, release the lever to the center position, then move back into the desired function.**

---

### SECURITY GUARD™ System (1, 2, 3, 4)

Moving the control lever from the center position toward any of the four digits on the face of the control body will also operate the SECURITY GUARD system (if equipped). See "SECURITY GUARD System" in this section for more information.

Function	Description of Operation
L WING IN/OUT	Move the control lever toward the left side of <b>LOWER</b> on the control face to move the left wing. The first time the lever is moved into the slot after the control is turned ON or another function is used, the wing will extend. Repeated use of lever in the same slot, without using another function, results in movement in the opposite direction from the previous movement. Function times out after 3.75 (OUT) or 3.25 seconds (IN).
R WING IN/OUT	Move the control lever toward the right side of <b>LOWER</b> on the control face to move the right wing. The first time the lever is moved into the slot after the control is turned ON or another function is used, the wing will extend. Repeated use of lever in the same slot, without using another function, results in movement in the opposite direction from the previous movement. Function times out after 3.75 (OUT) or 3.25 seconds (IN).

**FLEET FLEX ELECTRICAL SYSTEM**

Your Minute Mount® 2 system snowplow comes standard with user-controlled programmable features. These include:

- SECURITY GUARD™ electrical anti-theft system
- Smooth Stop/Soft Stop
- One-Touch FLOAT

This section provides more information about each feature, as well as instructions on how to enable or disable them. These features are offered to give you the ability to secure your snowplow and customize your plowing experience.

## SECURITY GUARD™ System

### Activation & Establishing a 4-Digit Security Code

---

**NOTE: The snowplow must be attached to the vehicle, and all the electrical connections must be connected prior to activating the security code function.**

---

The SECURITY GUARD feature was developed as an electrical anti-theft system. The system provides a deterrent from theft and/or non-permitted use by allowing you to electronically lock the snowplow's hydraulic functions.

All multiplex snowplow controls come equipped with the SECURITY GUARD system. To use this function, you must complete the "Activation" process.

1. Turn the vehicle ignition switch to the "ON" or "ACCESSORY" position. (It is not necessary to start the vehicle.)
2. Verify the control power indicator is OFF. If the power indicator light is red, the control is ON. Move the ON/OFF switch to "OFF" or push the ON/OFF button to turn the control OFF.
3. To activate the SECURITY GUARD mode, move the control lever to the #1 position or press the #1 button four consecutive times, and then to the #4 position or the #4 button four consecutive times (sequence: 1, 1, 1, 1, 4, 4, 4, 4). The green FLOAT light will flash quickly and the red power indicator light will turn ON, indicating the system is ready to accept your 4-digit security code.

Enter your 4-digit security code by moving the control lever to (or pressing the button for) any of the eight following positions: UP, DOWN, LEFT, RIGHT, 1, 2, 3 or 4.

Once you have entered your 4-digit security code, the FLOAT light will stop flashing and The power indicator light will turn OFF. This indicates that your 4-digit security code is entered and stored in the SECURITY GUARD™ system.

4. Once a 4-digit security code is established and the plow/vehicle electrical connection are lost/disconnected, the "SECURITY GUARD System" will recognize any control that has been programmed with the same 4-digit security code. Any control not programmed with the correct 4-digit security code will require the user to enter the established security code before activating the snowplow (see the Manual Unlock procedure).

---

**NOTE: If the control is turned ON prior to completing the programming procedure, your 4-digit security code will be cancelled.**

---

### **Manual Unlock**

If the "SECURITY GUARD System" is activated and you are using a control with a different 4-digit code than the established security code, you will be required to manually enter the 4-digit security code before operating a locked snowplow.

1. Turn the vehicle ignition to the "ON" or "ACCESSORY" position.
2. Move the ON/OFF switch to the "ON" position or push the ON/OFF button to switch the control ON.
3. The power indicator light will flash rapidly, indicating that the snowplow is locked.
4. Enter the 4-digit security code.

5. After entering the correct security code, the power indicator light will change from flashing rapidly to a solid light to indicate the snowplow has been successfully unlocked.

---

**NOTE: If the plow/vehicle electrical connection is lost or disconnected, the SECURITY GUARD™ system will reset, requiring any control that is not programmed with the established 4-digit security code to manually re-enter the security code to activate the snowplow.**

---

## Clearing an Established 4-Digit Security Code

1. Turn the vehicle ignition switch to the "ON" or "ACCESSORY" position.
2. If the snowplow is locked (the control power indicator light will be flashing at a fast rate), unlock the snowplow by following the Manual Unlock procedure.

3. Move the ON/OFF switch to the "OFF" position or push the ON/OFF button to switch the control OFF. Verify that the power indicator light is OFF.

4. With the control OFF, move the control lever to the #2 position or press the #2 button four consecutive times, and then to the #3 position or the #3 button four consecutive times. This sequence (2, 2, 2, 2, 3, 3, 3, 3) will clear the 4-digit security code from the SECURITY GUARD system. The FLOAT light will flash to indicate that the 4-digit security code was cleared.

---

**NOTE: To enter a new 4-digit security code see Activation & Establishing a 4-Digit Security Code.**

---

**Light Flash Indicators**

<b>POWER – Red</b>	<b>Function</b>
OFF	Control is OFF
Solid ON	Control is ON and active
Slow Flash	No communication
Fast Flash	Snowplow is locked—enter 4-digit security code to unlock

<b>FLOAT – Green</b>	<b>Function</b>
Solid ON	FLOAT function is active
Fast Flash	Security code activation in progress

**Additional Notes**

- The SECURITY GUARD™ system requires any control (other than the one with the assigned 4-digit security code) to enter the security code before the snowplow can be activated. Once the security code is established, the "SECURITY GUARD

System" recognizes that a control with the same security code is attached, and does not require a manual unlock to activate the snowplow. The system will recognize the control as "safe" and will automatically unlock.

- The "SECURITY GUARD System" is only fully functional with joystick control PN 49700 & 49900 and hand-held controls PN 29800 & 49800.
- In the event that a snowplow is locked and cannot be manually unlocked or reset, contact your Authorized Distributor.
- **REMINDER:** Record your security code for future reference.

## Smooth Stop/Soft Stop

Smooth stop, or "soft" stop, is a feature that allows the blade to coast to a stop when the button/lever is released. The result is smoother operation, reduction in shock to the hydraulic system and an increase in hose and valve life.

While there are advantages to having this feature, there are also advantages to temporarily disabling this feature. For example, to allow for more precise movements of the blade while operating in close distances to buildings and other obstacles.

All controls come standard with this feature ENABLED. To enable/disable this feature, perform the following steps. Performing the sequence multiple times will toggle the feature between enabled and disabled.

## Enable/Disable Procedure

1. Turn the vehicle ignition switch to the "ON" or "ACCESSORY" position. (It is not necessary to start the vehicle.)
2. Verify the control power indicator is OFF. If the power indicator light is red, the control is ON. Move the ON/OFF switch to "OFF" or push the ON/OFF button to turn the control OFF.
3. Move and hold the control lever to the R position or press and hold the R button while turning the control ON. The power indicator light will turn ON and the FLOAT light will flash, indicating the status of the feature.

## Light Flash Indicators

Light	Description
POWER – Red	Solid ON = Control is ON
FLOAT – Green	1 Flash = Smooth Stop Enabled 2 Flashes = Smooth Stop Disabled



## One-Touch FLOAT

One-touch FLOAT immediately activates the FLOAT mode and releases the blade to the ground, without having to hold the button or lever in LOWER. This can improve transition time when backing up to plow forward again, eliminating the time spent holding the control and waiting for the blade to fully drop.

All controls come standard with this feature DISABLED. To enable/disable this feature, perform the following steps. Performing the sequence multiple times will toggle the feature between enabled and disabled.

## Enable/Disable Procedure

1. Turn the vehicle ignition switch to the "ON" or "ACCESSORY" position. (It is not necessary to start the vehicle.)
2. Verify the control power indicator is OFF. If the power indicator light is red, the control is ON. Move the ON/OFF switch to "OFF" or push the ON/OFF button to turn the control OFF.
3. Move and hold the control lever to the LOWER position or press and hold the LOWER button while turning the control ON. The power indicator light will turn ON and the FLOAT light will flash, indicating the status of the feature.

## Light Flash Indicators

Light	Description
POWER – Red	Solid ON = Control is ON
FLOAT – Green	1 Flash = One-touch FLOAT Disabled 2 Flashes = One-touch FLOAT Enabled

## XtremeV™ BLADE POSITIONS

---

**NOTE: For best road clearance during transport, place the blade halfway between the straight and retracted (vee) positions. The scoop position is NOT RECOMMENDED during transport.**

---

The XtremeV snowplow can be used in five basic plowing positions.

## Straight Blade

Move both wings to form a straight blade for wide path plowing or "stacking" snow.

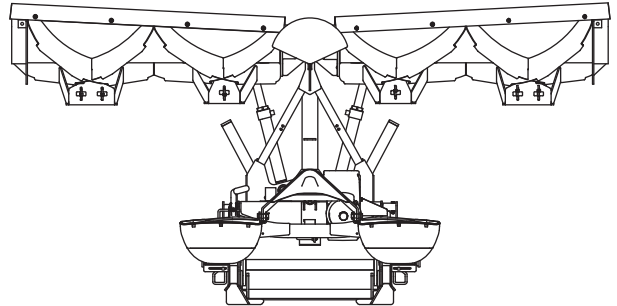

## Angled Blade

Move one wing "OUT" and the other wing "IN" to form an angled blade in either direction for general plowing and widening.

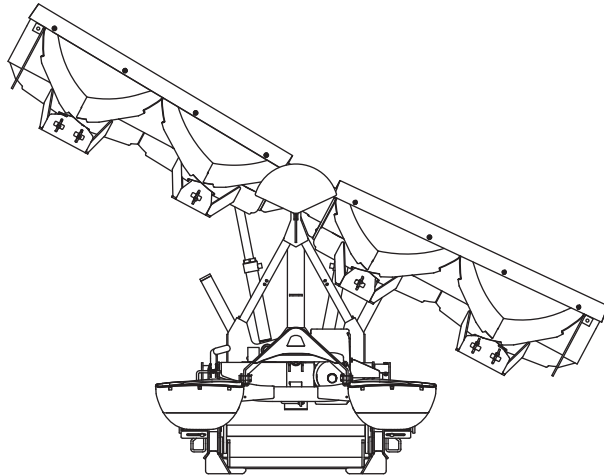

## Retracted (Vee) Blade

Move both wings "IN" towards the vehicle for initial break through plowing and plowing paths or walkways.

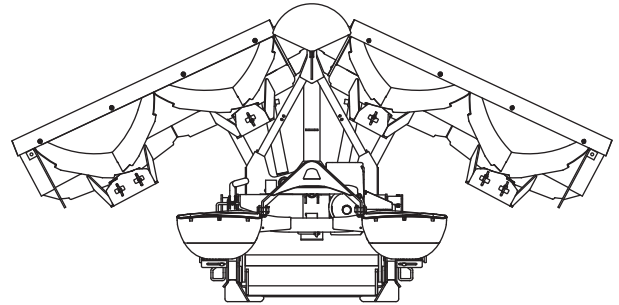

## Scoop Blade

Move both wings "OUT" away from the vehicle to form a scoop to "carry" snow with minimum spilloff.

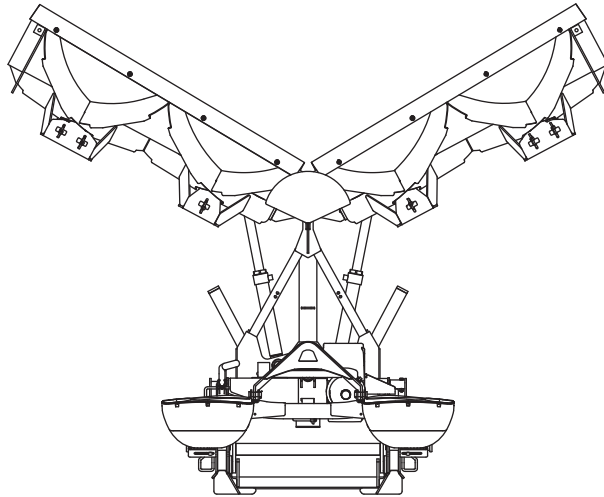

## Dogleg Blade

Move one wing to straight blade position and the other "OUT" to scoop blade position for clean up of windrows.

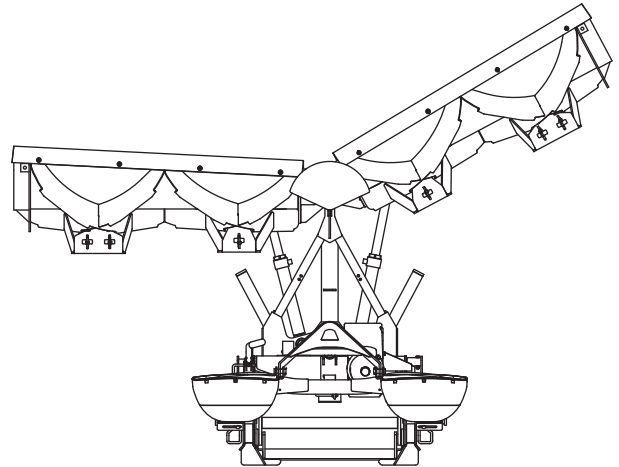

## XLS™ BLADE POSITIONS

The XLS snowplow can be used in four basic plowing positions.

---

**NOTE: Always transport the XLS snowplow with both wings fully retracted.**

---

## Retracted Blade

Move both wings "IN" to form a standard straight blade.

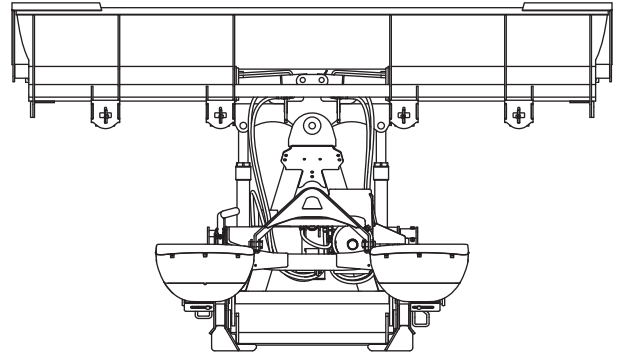

## Extended Blade

Move both wings "OUT" straight for an extra-wide blade for clearing large areas.

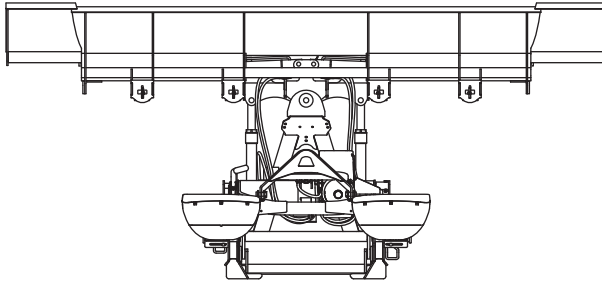

## Scoop Blade

Move both wings "OUT" and ahead of the vehicle to form a scoop to "carry" snow with minimum spilloff.

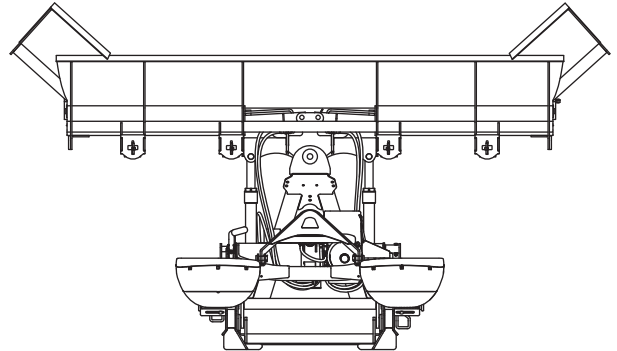

## Dogleg Blade

Move one wing to extended blade position and the other "OUT" to scoop blade position for clean up of windrows.

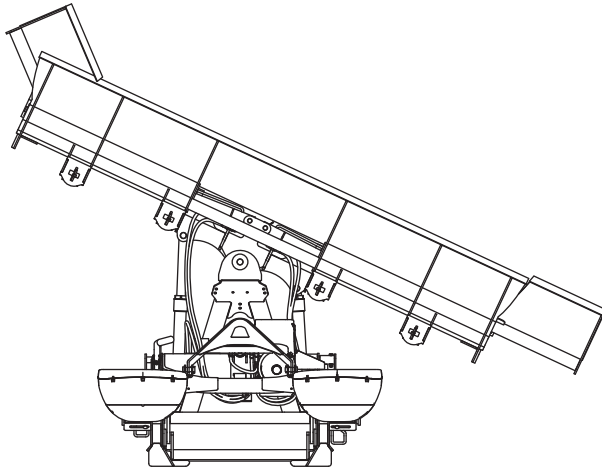

# OPERATING YOUR SNOWPLOW

---

## SNOWPLOW HEADLAMP CHECK

With all electrical plugs connected, check the operation of vehicle and snowplow headlamps.

Lights	Results
Parking Lamps	Both vehicle and snowplow lamps should be ON.
Right Turn Signal	Both vehicle and snowplow lamps should be ON.
Left Turn Signal	Both vehicle and snowplow lamps should be ON.

Connecting and disconnecting the electrical plugs should switch between the vehicle and snowplow headlamps as follows:

- Electrical plugs DISCONNECTED – Vehicle headlamps function normally.
- Electrical plugs CONNECTED – Vehicle headlamp functions transfer to the snowplow headlamps. On some DRL systems, both the vehicle and snowplow headlamps will function.

## Aiming the Headlamps

- Aim the snowplow headlamps with the snowplow mounted and raised in the transport position. See "Aiming Headlamp Beams" in the Maintenance section for instructions.
- Aim the vehicle headlamps with the snowplow removed from the vehicle.



# OPERATING YOUR SNOWPLOW

## ANTIWEAR SHOE ADJUSTMENT

### ⚠ WARNING

Blade can drop unexpectedly. Place blade on jack stands. Failure to do so could result in serious personal injury.

### ⚠ CAUTION

Do not store unused spacers on top of the shoe holder. This could damage the blade.

## Recommended Shoe Adjustments

**For gravel surfaces:** The bottom surface of the shoe should be  $1/4"$ – $1/2"$  below the cutting edge.

**For hard surfaces (concrete or asphalt):** The bottom surface of the shoe should be even with the cutting edge.

## Adjustment Procedure

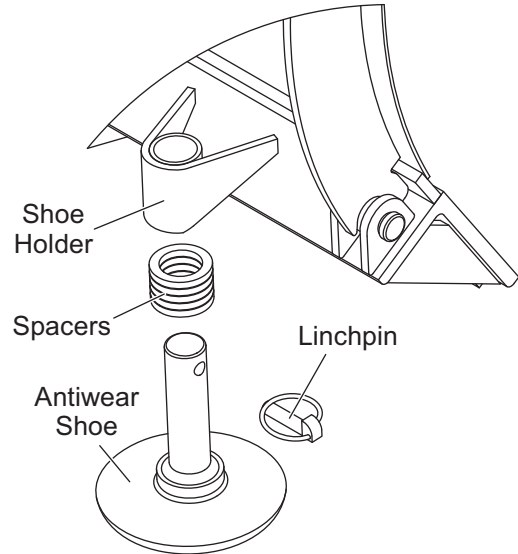

Standard shoe kit shown. An optional shoe kit, available for the HT Series™ and SD series blades, has a bolt-on shoe holder.

# OPERATING YOUR SNOWPLOW

---

1. Raise the blade 1' off the road surface, turn the control OFF and, from in front of the blade, place jack stands or sturdy blocking under the cutting edge.
2. Turn the control ON and lower the blade onto the jack stands or blocking. Turn the control and vehicle ignition OFF.
3. Remove the linchpin, and slide the antiwear shoe down and out of the shoe holder.
4. Remove one or more spacers from the shoe stem and reinstall the shoe into the shoe holder.
5. Reinstall the linchpin.
6. Turn the control and vehicle ignition ON. Raise the blade slightly from the jack stands. Turn the control OFF, and remove the jack stands.
7. Stand 8' clear of the blade drop zone when checking the height adjustment of the cutting edge to the road surface.
8. **DO NOT** store unused spacers on top of the shoe holder.

# OPERATING YOUR SNOWPLOW

## HYDRAULIC SYSTEM

The Insta-Act® hydraulic unit's valve manifold includes relief valves to prevent damage to the blade or vehicle if an obstacle is hit at either end of the blade. When force against the blade causes the pressure **in an extended ram** to exceed set limits, the relief valve opens allowing fluid to escape and the ram retracts.

For hydraulic fluid type and filling instructions, see "Annual Fluid Change" under "Hydraulic System" in the Maintenance section of this manual.

### HT Series™ Blades

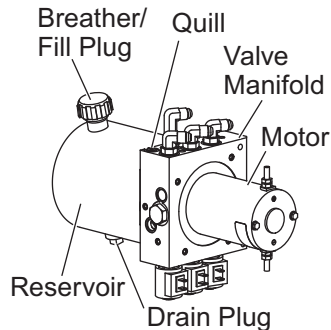

### Straight Blades

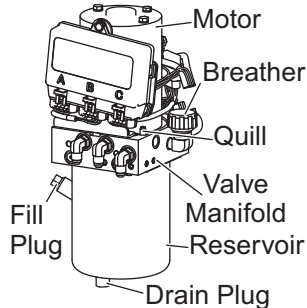

### XtremeV™ Blades

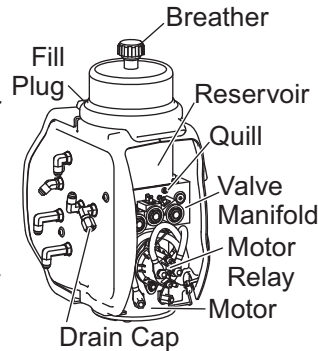

### XLS™ Blades

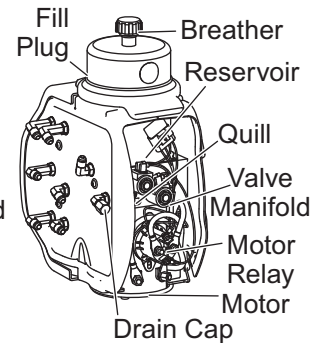

# OPERATING YOUR SNOWPLOW

## BLADE DROP SPEED ADJUSTMENT

### **⚠ WARNING**

Keep 8' clear of the blade drop zone when it is being raised, lowered or angled. Do not stand between the vehicle and blade or directly in front of blade. If the blade hits you or drops on you, you could be seriously injured.

HT Series™ Blades

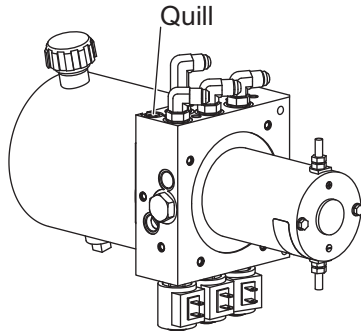

Straight Blades

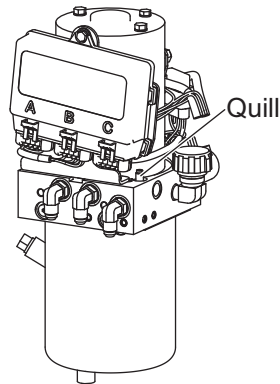

The quill in the valve manifold adjusts the blade drop speed.

1. Lower the blade to the ground before making the adjustment.

2. Remove the hydraulic unit cover.

**XtremeV™ and XLS™ hydraulic units:** raise the top cover retainer, remove the bottom cover retainer and remove the rear cover.

3. Turn the quill IN (clockwise) to decrease drop speed. Turn the quill OUT (counterclockwise) to increase drop speed.

# OPERATING YOUR SNOWPLOW

4. Stand 8' clear of the blade drop zone when checking adjustment.

5. Replace the hydraulic unit cover.

**XtremeV™ and XLS™ units:** replace the cover and reinstall the top and bottom cover retainers.

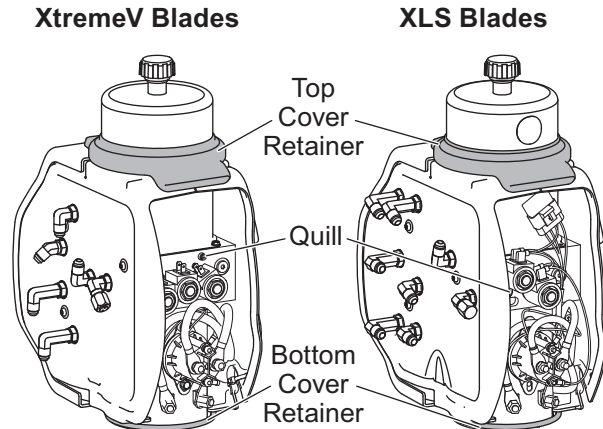

## SCRAPE LOCK ADJUSTMENT

Follow the instructions below to increase the pressure setting of the HT Series™ blade's scrape lock feature. The snowplow must be attached to the vehicle, and the snowplow battery cable and lighting harness must be connected before beginning this procedure.

1. Park the vehicle on a smooth, level, hard surface, such as concrete. Lower the blade to the ground and turn the control OFF. Leave the snowplow attached to the vehicle. Turn the vehicle ignition to the "OFF" position.
2. Disconnect the snowplow battery cable from the vehicle battery cable.
3. Remove the hydraulic unit cover.
4. Loosen the breather/fill plug slowly to relieve any pressure in the reservoir.

# OPERATING YOUR SNOWPLOW

- Using a "Tee" fitting, install a 500–600 psi gauge in the lift ram base hose.

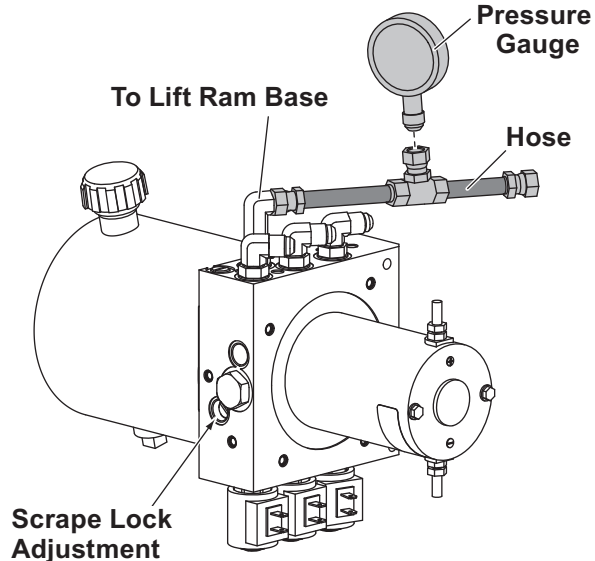

 = Increase Pressure

 = Decrease Pressure

- Retighten the breather/fill plug.
- Reconnect the snowplow battery cable to the vehicle battery cable.
- Turn the vehicle ignition to the "ON" or "Accessory" position. Turn the control ON.
- While pressing the RAISE button on the snowplow control, note the hydraulic gauge pressure reading as the blade is rising. (The pressure can **only** be read as the blade is rising. It may be necessary to perform this process more than once to obtain an accurate reading.) The recommended pressure is 350 psi.

## CAUTION

Never operate the unit while adjusting the scrape lock valve. Doing so will damage the scrape lock valve O-rings.

# OPERATING YOUR SNOWPLOW

---

10. If the hydraulic pressure reading is less than 350 psi, increase the pressure by turning the scrape lock valve stem clockwise 1/4 turn and retest pressure.
- 

**NOTE: Adjustments should be made in 1/4-turn increments.**

---

11. Repeat Steps 9 and 10 until the recommended pressure (350 psi) is obtained.
- 

**NOTE: Adjusting the scrape lock pressure in excess of the recommended pressure will increase amp draw and will shorten the life of the plow motor.**

---

12. Once the recommended pressure is obtained, lower the blade completely and turn the control OFF. Turn the vehicle ignition to the "OFF" position.
13. Disconnect the snowplow battery cable from the vehicle battery cable.

14. Loosen the breather/fill plug slowly to relieve any pressure in the reservoir.
15. Remove the hydraulic testing "Tee" fitting and gauge from the lift ram base hose.
16. Reconnect the lift ram base hose and tighten securely.

## CAUTION

**Do not mix different kinds of hydraulic fluid. Some fluids are not compatible and may cause performance problems and product damage.**

17. Check the hydraulic fluid level and add if necessary.
18. Retighten the breather/fill plug.
19. Replace the hydraulic unit cover.

# OPERATING YOUR SNOWPLOW

---

## TRANSPORTING SNOWPLOW

### **WARNING**

Position blade so it does not block headlamp beam.

Do not change blade position while traveling. You could suddenly lower blade accidentally.

### **CAUTION**

Transport speed should not exceed 45 mph (72 km/h). Further reduce speed under adverse travel conditions.

---

**NOTE:** For XtremeV™ blades, use care when driving or entering driveways with the snowplow in the retracted (vee) position. The outer ends of the cutting edges could contact the ground.

---

---

**NOTE:** Always transport the XLS™ snowplow with both wings fully retracted.

---

1. Completely raise the blade.
2. Adjust the blade height for maximum snowplow headlamp illumination.
3. Adjust the blade to the straight position.
4. Turn the control OFF to lock the blade in place.

---

**NOTE:** Overheating is unlikely under normal driving conditions, but occasionally the snowplow may be positioned where it deflects air away from the radiator. If this occurs, stop the vehicle and raise, lower or angle the snowplow slightly to correct overheating.

---

---

**NOTE:** Only the driver should be in the vehicle cab when the snowplow is attached.

---



# OPERATING YOUR SNOWPLOW

---

## DRIVING AND PLOWING ON SNOW AND ICE

### CAUTION

**Drinking then driving or plowing is very dangerous. Your reflexes, perceptions, attentiveness and judgement can be affected by even a small amount of alcohol. You can have a serious or even fatal collision if you drive after drinking. Please, do not drink and then drive or plow.**

Refer to your vehicle owner's manual instructions for driving in snow and ice conditions. Remember when you drive on snow or ice, your tires will not get good traction. You cannot accelerate as quickly, turning is more difficult and you will need longer braking distance.

Wet and hard packed snow or ice offers the worst tire traction. It is very easy to lose control. You will have difficulty accelerating. If you do get moving, you may have poor steering and difficult braking which can cause you to slide out of control.

Here are some tips for driving in these conditions:

- Drive defensively.
- Do not drink, then drive or plow snow.
- Plow or drive only when you have good visibility for operating a vehicle.
- If you cannot see well due to snow or icy conditions, you will need to slow down and keep more space between you and other vehicles.
- Slow down, especially on higher-speed roads. Your headlamps can light up only so much road ahead.
- If you are tired, pull off in a safe place and rest.
- Keep your windshield and all glass on your vehicle clean to see around you.
- Dress properly for the weather. Wear layers of clothing, as you get warm you can take off layers.

# OPERATING YOUR SNOWPLOW

---

## PLOWING SNOW

### WARNING

Never plow snow with head out the vehicle window. Sudden stops or protruding objects could cause personal injury.

### CAUTION

Wear a seat belt when plowing snow. Hidden obstructions could cause the vehicle to stop suddenly resulting in personal injury.

### CAUTION

Flag any obstructions that are hard to locate under snow to prevent damage to product or property.

### CAUTION

Never stack snow with the blade angled. This could damage the snowplow or the vehicle bumper.

### CAUTION

Plowing speed should not exceed 10 mph (16 km/h).

---

**NOTE:** Only the driver should be in the vehicle cab when the snowplow is attached.

---

# OPERATING YOUR SNOWPLOW

---

## General Instructions

1. Before plowing, make sure you know of any obstructions hidden beneath the snow such as bumper stops in parking lots, curbs, sidewalk edges, shrubs, fences or pipes sticking up from the ground. If unfamiliar with the area to be plowed, have someone familiar with the area point out obstacles.
2. If possible and you have good visibility, plow during the storm rather than letting snow accumulate.
3. Do not exceed 10 mph (16 km/h) when plowing snow.
4. When you are stacking snow, begin raising the blade as you come close to the stack. This will let the blade ride up the stack.

## Hard-Packed Snow

1. On blades equipped with shoes, raise the antiwear shoes so that the cutting edge comes into direct contact with the pavement. **DO NOT stack spare spacers on top of shoe holder.**
2. Use the lowest gear to place maximum power behind the cutting edge.
3. An angled blade is more effective for removing hard-packed snow.

# OPERATING YOUR SNOWPLOW

---

## Deep Snow

1. For straight blades, shear off top layers by plowing with the blade raised 3 to 4 inches for the initial pass. For XtremeV™ blades, move the blade into the fully retracted (vee) position and make an initial pass.
2. Bite into the edges using only a partial blade width until the job is cut down to size for full blade plowing.
3. When plowing deep snow, be sure to keep vehicle moving.
4. Ballast is suggested for maximum traction. Secure ballast behind the rear axle. Do not exceed vehicle's GVWR and GAWR.
5. For increased traction use tire chains where legal.

Rule of thumb:

6" of snow — plow with entire blade width;

9" of snow — plow with 3/4 blade width;

12" of snow — plow with 1/2 of the blade.

For XLS™ blades in scoop position, plow all depths with entire blade width.

Experience and "feel" are the best guides.

# OPERATING YOUR SNOWPLOW

---

---

## Clearing Driveways

1. Head into the driveway with the blade angled and plow the snow away from any buildings. Widen the driveway by rolling snow away from any buildings.
2. If a building is at the end of the driveway, plow to within a vehicle length of the building. Push as much snow as possible off the driveway.
3. With a raised blade, drive through the remaining snow to the building. Drop the blade and "back drag" the snow away from the building at least one vehicle length. Repeat if necessary.
4. Back the vehicle up to the building and plow forward, removing the remaining snow from the driveway. Check municipal ordinances for proper disposal of snow.

## Clearing Parking Lots

1. Clear areas in front of buildings first. With the blade raised, drive up to the building. Drop the blade and "back drag" the snow away from the building. When snow is clear of the buildings, turn the vehicle around and push snow away from the buildings toward the outer edges of the lot.
2. Plow a single path down the center in the lengthwise direction.
3. With the blade in the scoop, angle or dogleg position, plow successive strips lengthwise until the area is cleared and snow is "stacked" around the outer edges.
4. If snow is too deep to clear in the above manner, clear main traffic lanes as much as possible.

# OPERATING YOUR SNOWPLOW

---

## PARKING WITH SNOWPLOW ATTACHED

### **WARNING**

**Lower blade when vehicle is parked. Keep 8' clear of blade drop zone. Temperature changes could change hydraulic pressure, causing the blade to drop unexpectedly or damaging hydraulic components. Failure to do this could result in serious personal injury.**

Whenever you park your vehicle, completely lower the blade to the ground.

## TOWING DISABLED OR STUCK VEHICLE

Do not use any snowplow components as an attaching point when retrieving, towing or winching a disabled or stuck vehicle.

# DETACHING SNOWPLOW FROM VEHICLE & STORAGE

## DETACHING SNOWPLOW

### WARNING

Keep 8' clear of the blade drop zone when it is being raised, lowered or angled. Do not stand between the vehicle and blade or directly in front of blade. If the blade hits you or drops on you, you could be seriously injured.

### WARNING

Inspect snowplow components and fasteners for wear or damage whenever attaching or detaching the snowplow. Worn or damaged components could allow the snowplow to drop unexpectedly.

### CAUTION

Never pull jack lock when blade assembly is not attached to vehicle. The headgear assembly will suddenly drop.

**NOTE:** The blade must be in the straight position when attaching or detaching the snowplow.

During the off-season, the control can be removed. Disconnect the connector in the cab and store the control in the glove box of the vehicle.

### Detaching Steps:

1. Park the vehicle on a smooth, level, hard surface, such as concrete. Lower the blade to the ground.
2. Pull and hold jack lock out. Jack will drop to ground. Then pull pin release handle away from stop and jack lock. Release jack lock. Verify jack is locked by trying to lift jack.

**HT Series™ Blades:** Pull Jack Lock out, rotate Jack into DOWN position and engage Jack Lock.

Push down on Jack until it hits the ground.

# DETACHING SNOWPLOW FROM VEHICLE & STORAGE

- Stand in front of blade. While pushing headgear toward vehicle with left hand, push pin release handle down to disengage connecting pins. Make sure connecting pins are fully retracted. If unable to push headgear from in front of blade, stand in front of headgear on the driver's side and push headlamp bracket.

**HT Series™ Blades:** Stand in front of blade. While pushing the Headgear Push Bar toward the vehicle with left hand, pull Pin Release Handle down to disengage Connecting Pins. Make sure Connecting Pins are fully retracted.

## **CAUTION**

**On 2-plug electrical systems, plug covers shall be used whenever snowplow is disconnected. Vehicle Battery Cable is 12-volt unfused source.**

- Detach all electrical connectors.

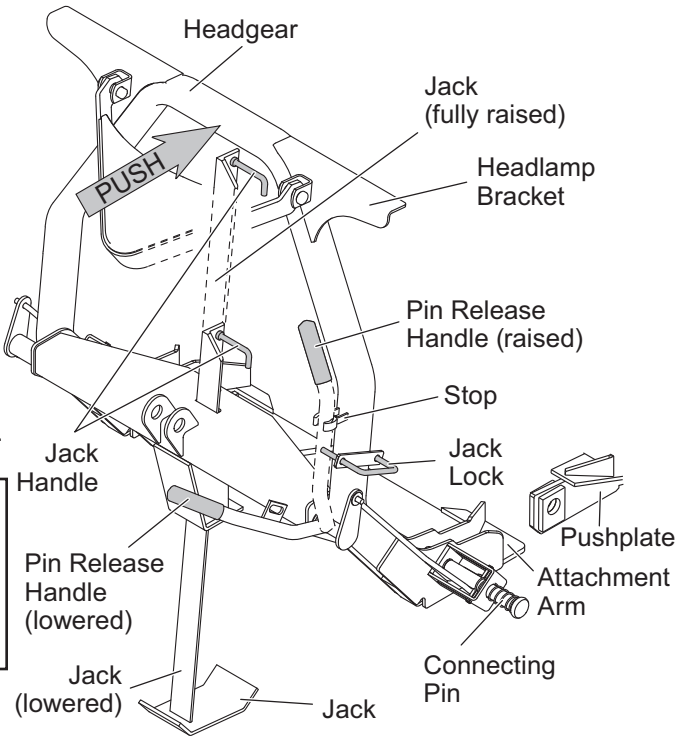



# DETACHING SNOWPLOW FROM VEHICLE & STORAGE

**NOTE:** After each use of the snowplow, reapply dielectric grease to the electrical plugs to maintain the protective coating on the terminals.

**NOTE:** Place electrical plugs in storage position. The driver-side and center plug on 3-plug electrical systems are joined for storage. The passenger-side and 2-plug systems are equipped with plug covers.

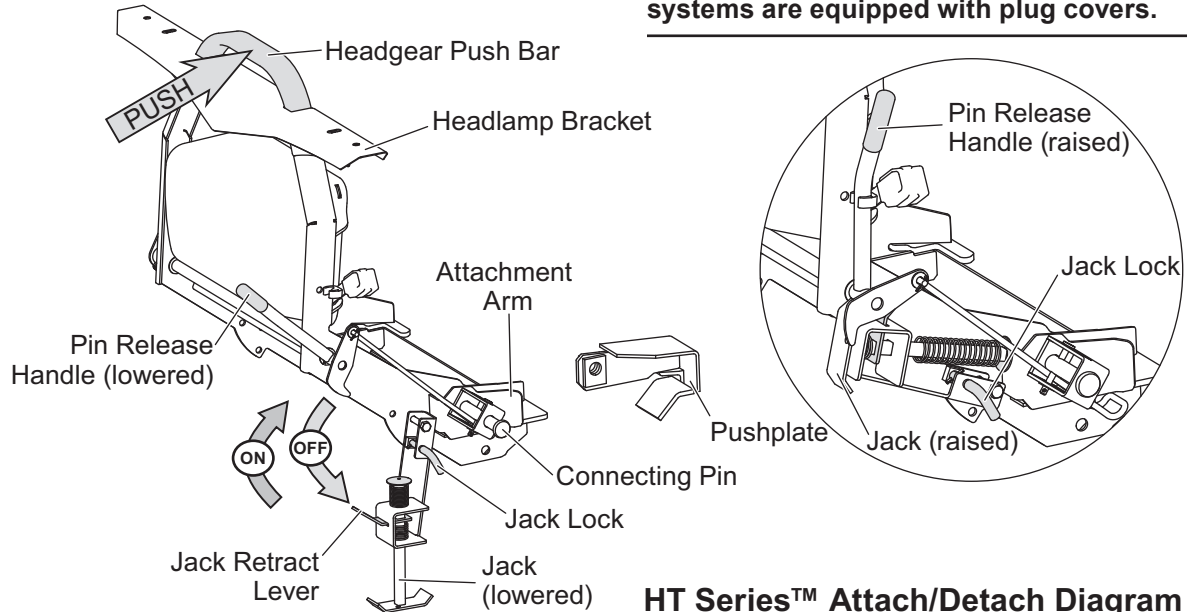

# DETACHING SNOWPLOW FROM VEHICLE & STORAGE

---

## STORAGE

Your snowplow is designed to be moved into a storage location using your vehicle and plow attaching system. For easier attaching of the snowplow, store it on a hard, level surface.

# MAINTENANCE

---

## AIMING HEADLAMP BEAMS

Tighten headlamp fasteners to 45 ft-lb once correct visual aim is achieved.

1. Place vehicle on a level surface 25 feet in front of a matte-white screen, such as a garage door. The screen should be perpendicular both to the ground and to the vehicle centerline.
2. The vehicle should be equipped for normal operation. The snowplow blade should be in place and in raised position. Below are steps listed by the Society of Automotive Engineers (SAE) pertinent to headlamp aiming in specification #SAE J599d.
3. Prepare vehicle for headlamp aim or inspection. Before checking beam aim, the inspector will:
  - a. Remove ice or mud from under fenders.
  - b. Set tire inflation pressures to the values specified on vehicle information label.
  - c. Check springs for sag or broken leaves.
  - d. See that there is no load in the vehicle other than the driver and ballast as specified in the Kit Selection Guide.
  - e. Check functioning of any automatic vehicle leveling systems and specific manufacturer's instructions pertaining to vehicle preparation for headlamp aiming.
  - f. Clean lenses.
  - g. Check for bulb burnout and proper beam switching.
  - h. Stabilize suspension by rocking vehicle sideways.

# MAINTENANCE

4. Mark (or tape) the vertical centerline of the snowplow headlamps and the vertical centerline of the vehicle on the screen. Mark the horizontal centerline of the snowplow headlamps on the screen (distance from ground to snowplow headlamp centers).
5. Align the top edge of the high intensity zone of the snowplow lower beam below the horizontal centerline and the left edge of the high intensity zone on the vertical centerline for each snowplow headlamp. (Refer to the diagram below.)

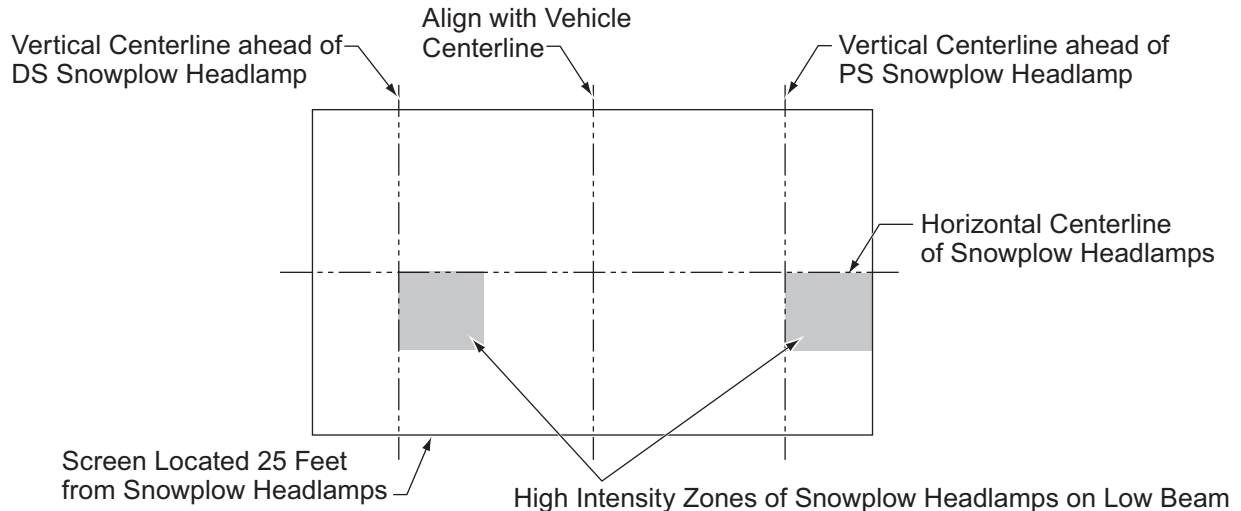

# MAINTENANCE

---

## PRESEASON CHECK

### WARNING

**Lower blade when vehicle is parked. Keep 8' clear of blade drop zone. Temperature changes could change hydraulic pressure, causing the blade to drop unexpectedly or damaging hydraulic components. Failure to do this could result in serious personal injury.**

Before the snow season, check your equipment to make sure it's in working condition. Here are some tips for getting your equipment ready:

- Clean and tighten all electrical connections and coat with dielectric grease to prevent corrosion.
- Check hydraulic system for leaks and cracked or damaged hoses.
- Drain hydraulic system and refill with recommended hydraulic fluid. For hydraulic fluid type and filling instructions, see "Annual Fluid Change" under "Hydraulic System" in this section of the manual.
- Replace worn or damaged parts.
- Check all mounting points and tighten fasteners, on both snowplow and vehicle. Verify all cotter pins are in place.
- Repaint blade assembly and attachments, as necessary, to protect the metal.
- Install auxiliary and flashing lights for compliance and visibility in accordance with local regulations.
- Check headlamps, auxiliary lights, heater and windshield wipers for proper operation.

# MAINTENANCE

---

- Inspect and test your battery. Recharge or replace as necessary.
- Ballast may be necessary, or beneficial, on some vehicles to provide maximum traction, braking and handling.
- Any ballast material (such as sand and blocks) must be solidly secured to the vehicle preventing it from moving under harsh plowing conditions.

## POSTSEASON MAINTENANCE

### CAUTION

**Servicing the trip springs without special tools and knowledge could result in personal injury. See your authorized FISHER® outlet for service.**

---

**NOTE: Coat all electrical connections with dielectric grease.**

---

- Clean and paint blade and attachments as needed.
- Be sure lift ram is fully collapsed so the rod is not exposed.
- Apply general purpose petroleum grease to exposed chrome surfaces of the rams to prevent rust.
- Lubricate all pivot points (e.g., connecting pin assembly and lower spring anchor) with general purpose petroleum grease.

# MAINTENANCE

## MAINTENANCE AND ADJUSTMENT

### **⚠ WARNING**

**Lower blade when vehicle is parked. Keep 8' clear of blade drop zone. Temperature changes could change hydraulic pressure, causing the blade to drop unexpectedly or damaging hydraulic components. Failure to do this could result in serious personal injury.**

Your FISHER® snowplow is designed for rugged, dependable service. Though, like the vehicle on which it is mounted, it needs regular care and maintenance.

Check the following before and frequently during the plowing season:

1. Make sure all fasteners, mounting bolts and hydraulic connections are tight.

2. Make sure all electrical connections including grounds are clean, tight, free of rust or corrosion and are coated with dielectric grease.
3. Check all plugs and seals for hydraulic fluid leaks. Repair as necessary.
4. Lubricate all moving parts, especially the connecting pin extractors, for ease of operation. Not doing so will make operation of the mount difficult and possibly damage components.

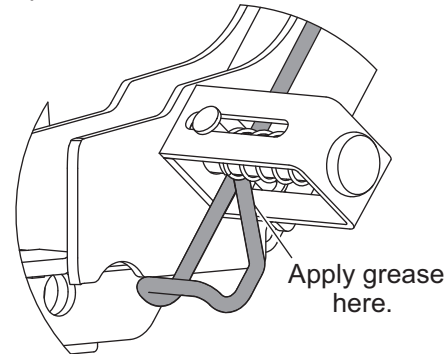

## XtremeV™ CUTTING EDGE WEAR and LEVELING ADJUSTMENT PROCEDURE

After the snowplow has been installed on the vehicle in the correct configuration, a fine adjustment can be made to bring the cutting edges of the snowplow in full contact with the ground across the entire cutting edge. This adjustment feature should be used as the cutting edges begin to wear in order to maintain an even wear pattern across both cutting edges and provide good scraping action.

1. The snowplow must be installed on a properly ballasted vehicle, in the correct configuration.
2. The vehicle and the snowplow must be on a level surface.
3. Place the blade wings in the scoop position on the ground with no tension on the lift chain.

4. Remove the rear push assembly to T-frame fasteners. Loosen the front fasteners and allow the blade to find a level position.

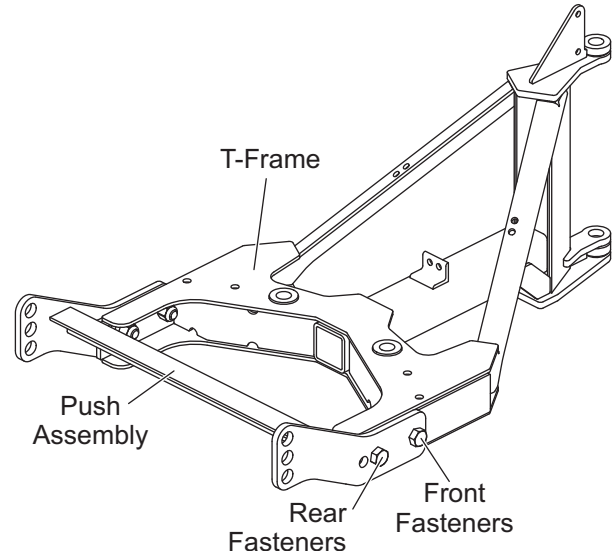



5. Select the hole in the rear of the T-frame that is best aligned with the rear hole in the push assembly and reinstall the rear fasteners. Tighten all four fasteners to 250 ft-lb.
6. Raise and lower the blade several times. The cutting edge should be contacting the level surface across the full length of the cutting edge.
7. Verify that the cutting edges remain in full contact with the ground while the wings are shifted from the scoop position to a retracted (vee) position.

Complete this procedure as often as required to provide even cutting edge wear. Replace the cutting edge(s) on your XtremeV™ blade when worn to within 1" of the carriage bolts.

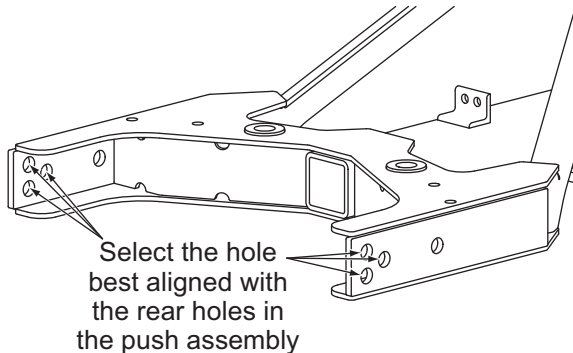

# MAINTENANCE

## HYDRAULIC SYSTEM

### Fluid Level

#### **⚠ CAUTION**

Do not mix different kinds of hydraulic fluid. Some fluids are not compatible and may cause performance problems and product damage.

**NOTE:** On XtremeV™ and XLS™ blades, add fluid only when all rams are retracted.

**NOTE:** Remove fill plug slowly to relieve any pressure in reservoir.

1. With the Minute Mount® 2 system attached to the vehicle, activate the control.
2. For straight blades, any angle will do, but for XtremeV and XLS blades, move blade wings to fully retracted (vee) position.
3. Activate the control FLOAT function and manually collapse the lift ram all the way.
4. Turn the control OFF.

#### HT Series Blades

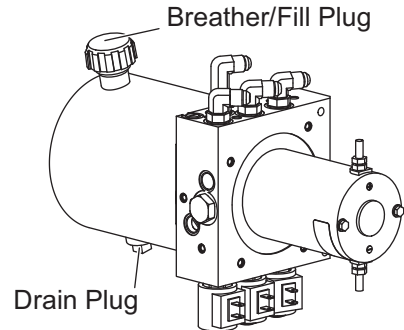

# MAINTENANCE

5. Remove the fill plug.
6. **HT Series™ Blades:** Fill the reservoir to within 2-1/2" from the top of the fill hole and replace the fill plug.

**XtremeV™, XLS™ and other Straight Blades:** Fill the reservoir to the top of the fill hole and replace the fill plug.

For fluid recommendations see "Annual Fluid Change" in this section.

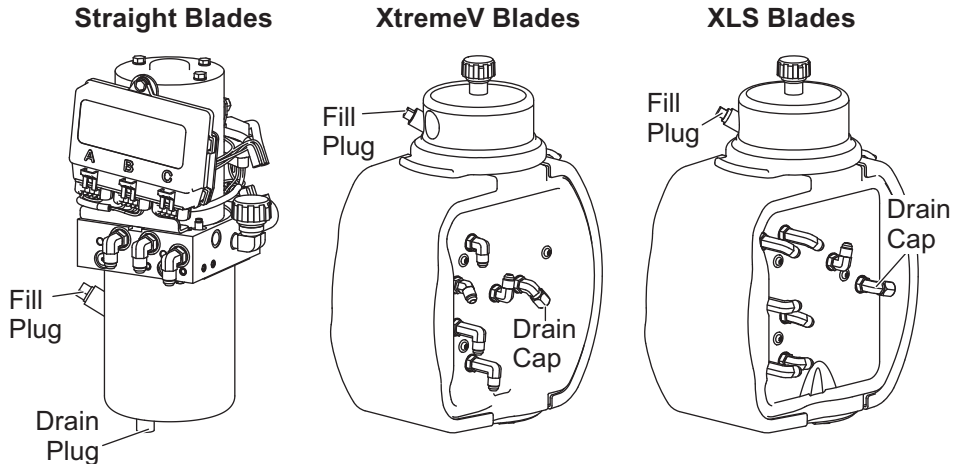

# MAINTENANCE

---

## Annual Fluid Change

### CAUTION

**Change the fluid at the beginning of each plowing season. Failure to do this could result in condensation buildup during the non-plowing season.**

### CAUTION

**Do not mix different kinds of hydraulic fluid. Some fluids are not compatible and may cause performance problems and product damage.**

1. Perform this operation with the snowplow attached to the truck on a hard level surface. Disable the one-touch FLOAT feature, if enabled. (See "One-Touch FLOAT" in the Operating Your Snowplow section of this manual.)
  2. Place a sturdy block under the A-frame/ T-frame so the blade will be suspended a few inches off the ground when lowered.
  3. Lower the blade until its weight is supported by the block.
  4. Activate the control FLOAT function and manually collapse the lift ram all the way. (Not required for HT Series™ blades.) Turn the control OFF.
- 
- NOTE: Loosen the fill plug slowly to relieve any pressure in the reservoir.**
- 
5. Remove the drain plug located in the bottom of the hydraulic reservoir for straight blades, or the drain cap located on the fitting side of the hydraulic unit for XtremeV™ and XLS™ blades. (See illustrations on the previous page.)
  6. Completely drain the reservoir and replace the drain plug/cap.

# MAINTENANCE

---

7. Carefully note hose routings and the positions of any protective hose wraps for proper reassembly.
8. Remove the angle ram hoses from the fittings on the hydraulic unit and place in a drain pan or suitable container. **(See the following illustrations and Hydraulic Hose or Fitting Replacement instructions.)**
9. Manually angle the blade fully in each direction to remove fluid from the angle rams. Do not allow the hose(s) from the extending ram or the opposite side of the ram (XtremeV™ blades only) to take fluid back in.
10. Reconnect the angle ram hoses to the proper fittings. Reinstall all protective hose wraps in their original positions. **(See the following illustrations for your snowplow type and Hydraulic Hose or Fitting Replacement instructions.)**

## WARNING

**Keep 8' clear of the blade drop zone when it is being raised, lowered or angled. Do not stand between the vehicle and blade or directly in front of blade. If the blade hits you or drops on you, you could be seriously injured.**

# MAINTENANCE

## Hose Routing for HD, MC and X Series Straight Blades

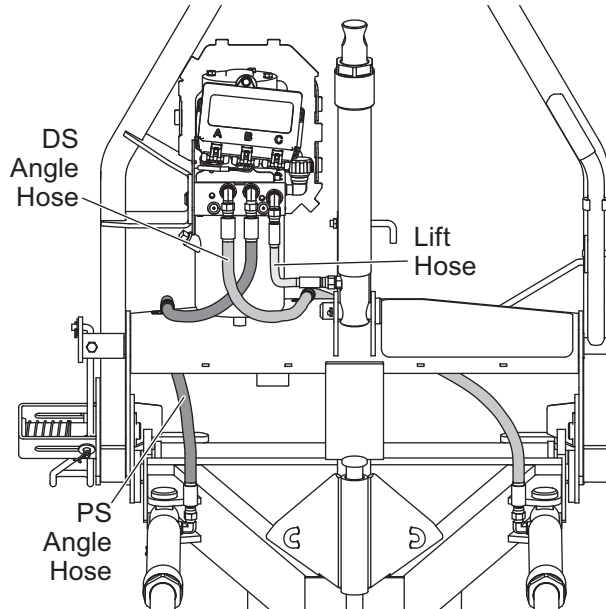

## Hose Routing for SD Series Straight Blades

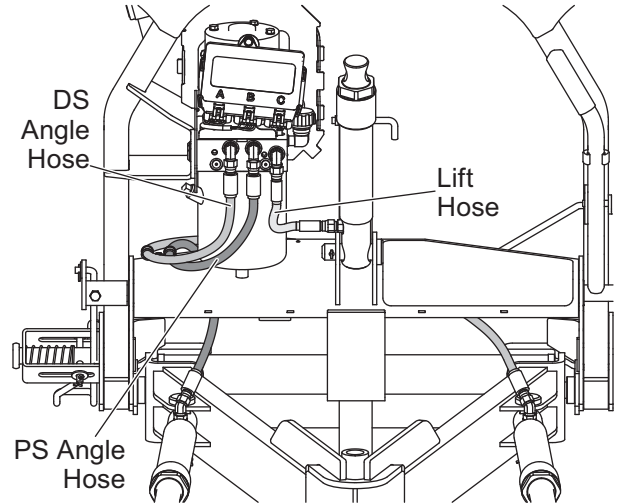

# MAINTENANCE

## Hose Routing for HT Series™ Straight Blades

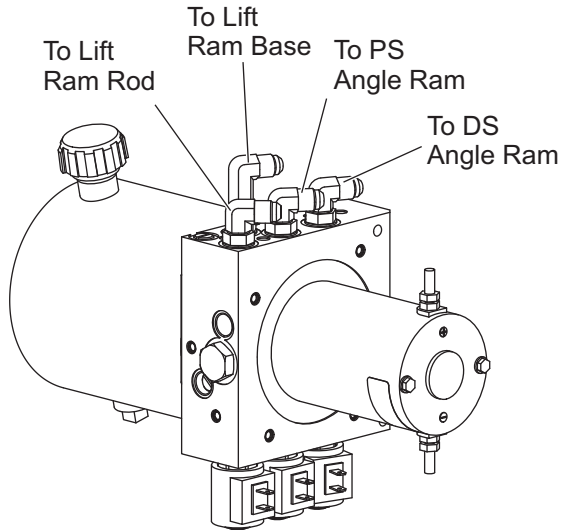

## Hose Routing for XtremeV™ Blades

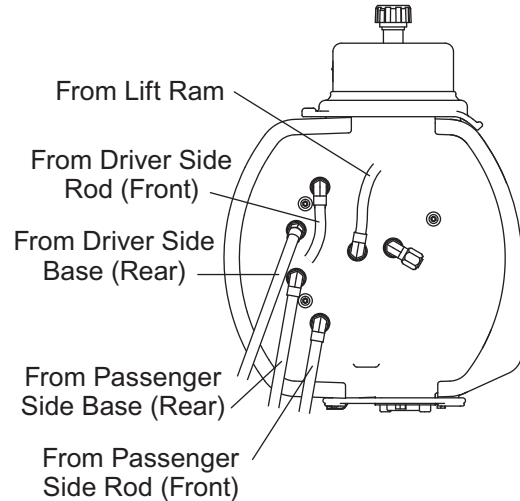

# MAINTENANCE

## Hose Routing for XLS™ Blades

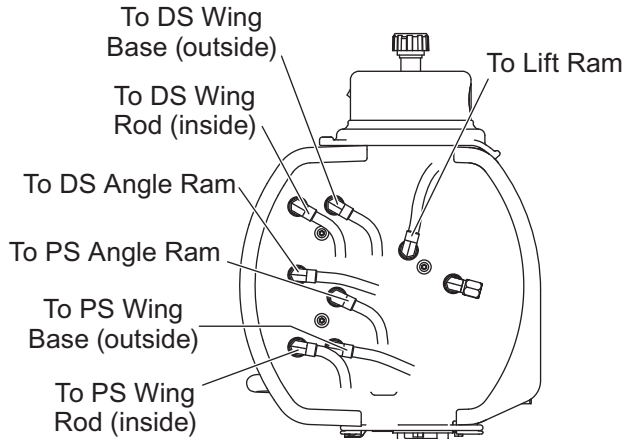

### **⚠ CAUTION**

**Do not raise blade during fill process as this may cause pump cavitation.**

11. For straight blades, any angle will do, but XtremeV™ and XLS blades must be in the fully retracted (vee) position. With the lift ram fully retracted, fill the reservoir with FISHER® EZ Flow hydraulic fluid to  $-40^{\circ}\text{F}$  ( $-40^{\circ}\text{C}$ ), or other fluid conforming to Military Specification MIL-H-5606A, such as Mobil Aero HFA or Shell AeroShell® Fluid 4. Replace the fill plug.

**NOTE: On XtremeV and XLS blades, add fluid only when all rams are retracted.**

AeroShell® is a registered trademark (®) of Shell Oil Company.



# MAINTENANCE

---

## Air Removal – HT Series™ and Straight Blades

12. Turn the control ON and completely angle the blade to the left and right several times. Turn the control OFF.
13. Fill the reservoir to the top of the fill hole and replace the fill plug.

---

**NOTE: Loosen fill plug slowly to relieve any pressure in the reservoir.**

---

14. Turn the control ON and raise and lower the snowplow several times. Activate the control FLOAT function and manually collapse the lift ram all the way (not required for HT Series blades) after each lowering of the blade. Turn the control OFF.

15. **HT Series Blades:** Fill the reservoir to within 2-1/2" from the top of the fill hole and replace the fill plug.

**All other Straight Blades:** Fill the reservoir to the top of the fill hole and replace the fill plug.

### **WARNING**

**To prevent accidental movement of the blade, always turn the control OFF whenever the snowplow is not in use. The power indicator light will turn OFF.**

# MAINTENANCE

---

## Air Removal – XtremeV™ Blades

11. Turn the control ON and completely extend and retract the driver-side wing several times. With all rams fully retracted, turn the control OFF.
12. Fill the reservoir to the top of the fill hole and replace the fill plug.

---

**NOTE: Loosen fill plug slowly to relieve any pressure in the reservoir.**

---

13. Repeat Steps 11 and 12 for the passenger-side wing.
14. Turn the control ON and raise and lower the snowplow several times. Activate the control FLOAT function and manually collapse the lift ram all the way after each lowering of the blade. With all rams fully retracted, turn the control OFF.
15. Fill the reservoir to the top of the fill hole and replace the fill plug.

### **WARNING**

**To prevent accidental movement of the blade, always turn the control OFF whenever the snowplow is not in use. The power indicator light will turn OFF.**

# MAINTENANCE

---

## Air Removal – XLS™ Blades

11. Turn the control ON and completely extend and retract the driver-side wing several times. Repeat for the passenger-side wing. With the wing and lift rams fully retracted, turn the control OFF.
12. Fill the reservoir to the top of the fill hole and replace the fill plug.

---

**NOTE: Loosen fill plug slowly to relieve any pressure in the reservoir.**

---

13. Turn the control ON. Angle the blade fully left and right and raise and lower the snowplow several times. Activate the control FLOAT function and manually collapse the lift ram all the way after each lowering of the blade. With all rams fully retracted, turn the control OFF.
14. Fill the reservoir to the top of the fill hole and replace the fill plug.

### **WARNING**

**To prevent accidental movement of the blade, always turn the control OFF whenever the snowplow is not in use. The power indicator light will turn OFF.**

# MAINTENANCE

---

## Hose or Fitting Replacement

### WARNING

**Lower blade when vehicle is parked. Keep 8' clear of blade drop zone. Temperature changes could change hydraulic pressure, causing the blade to drop unexpectedly or damaging hydraulic components. Failure to do this could result in serious personal injury.**

**DO NOT** use thread sealant/tape on hoses or fittings. This could damage the product. Follow recommended replacement procedures for fittings and hoses.

1. Lower the snowplow completely and turn the control OFF.

---

**NOTE: Loosen fill plug slowly to relieve any pressure in the reservoir.**

---

2. Carefully note hose routings and the positions of any protective hose wraps for proper reassembly.
3. Loosen hoses or fittings slowly to relieve any residual pressure.
4. To remove a hose, loosen and unscrew the hose flare nut from the fitting.
5. To remove a fitting, loosen the jam nut and unscrew the fitting from the port.

# MAINTENANCE

---

---

## Procedure for Installing Hydraulic Fittings and Hoses

---

**NOTE: Overtorquing JIC hose fitting ends will result in a fractured fitting.**

---

**DO NOT** use any type of sealant or tape on the fittings or hoses. This could damage product. Always use two wrenches to ensure proper tightening of fittings and hoses.

**Use the following procedure to install SAE O-ring fittings in valve block and rams:**

1. Turn the jam nut on the fitting as far back as possible.
2. Lubricate the O-ring with clean hydraulic fluid.
3. Screw the fitting into the port by hand until the washer contacts the port face and shoulder of the jam nut threads.
4. Unscrew the fitting to the proper position no more than one full turn.
5. Using two wrenches, hold the fitting body in position and tighten the jam nut until the washer again contacts the port face, then tighten an additional 1/8–1/4 turn to lock the fitting in place. Final torque on the jam nut should be approximately 20 ft-lb.

# MAINTENANCE

---

## Use the following procedure to install hydraulic hoses:

1. Screw the flare nut onto the fitting flare and hand tighten.
2. Align the hose so there are no twists or sharp bends and so it will not be pinched or pulled by moving parts.
3. Using two wrenches, hold the hose in position and tighten the flare nut 1/8–1/4 turn beyond hand tight. Final torque on the flare nut should be approximately 20 ft-lb.
4. Reinstall any protective hose wraps in their original positions.

## FUSE REPLACEMENT

The vehicle electrical system contains several automotive blade-style fuses. The snowplow park/turn and control power is covered by fuses in the under hood snowplow wiring. The control fuse is "hot" when the vehicle ignition switch is ON and the electrical connections to the snowplow are completed.

See the Harness Diagram applicable to the electrical system on your snowplow at the end of this manual for fuse ratings and locations.

The XtremeV™ hydraulic unit harness system contains four automotive blade-style mini fuses. The 3-solenoid harness (to Port B on the hydraulic unit module) and 8-solenoid harness (to Port C) each contain two 4-amp mini fuses.

# MAINTENANCE

---

The XLS™ hydraulic unit harness system contains four automotive blade-style mini fuses. The 2-solenoid harness (to Port B on the hydraulic unit module) and 6-solenoid harness (to Port C) each contain two 4-amp mini fuses.

The Straight Blade and HT Series™ hydraulic unit harness systems each contain two 4-amp automotive blade-style mini fuses in the 3-solenoid harness (to Port B on the hydraulic unit module).

If a problem should occur and fuse replacement is necessary, the replacement fuse must be of the same type and amperage rating as the original. Installing a fuse with a higher rating can damage the system and could start a fire.

## VEHICLE

The snowplow operating vehicle shall be maintained according to manufacturer's recommendations. Tire pressure shall be maintained according to manufacturer's recommendation.

## RECYCLE

When your snowplow has performed its useful life, the majority of its components can be recycled as steel or aluminum. Hydraulic fluid shall be disposed of according to local regulations. The balance of the parts made of plastic shall be disposed of in a customary manner.

# MAINTENANCE

---

## EMERGENCY PARTS/TOOLS

- 2 – 10" Adjustable Wrenches
- 1 – Medium Flat Blade Screwdriver
- 1 – Pair of Common Pliers
- 1 – #20 & #30 TORX® Drivers
- Automotive Blade-Style Fuses (See applicable Harness Diagram for the correct fuse ratings for your snowplow.)
- 4-Amp Automotive Blade-Style Mini Fuses
- Funnel
- 12V DC Test Light
- Flashlight
- 1/8" & 3/16" Allen Wrenches
- 1/4" Ratchet, 6" Extension, 1/4" & 5/16" Sockets
- Electrical Tape
- Small Pencil Magnet
- 1 – Quart FISHER® EZ Flow Hydraulic Fluid



TORX® is a registered (®) trademark of Textron, Inc.



## TROUBLESHOOTING

If you have followed all of the guidelines in the Maintenance section of this manual and cannot resolve issues with the operation of your FISHER® snowplow, contact one of our authorized outlets for repair information, or visit us online at [www.fisherplows.com](http://www.fisherplows.com). Our Web site has a complete listing of authorized outlets in your area as well as a complete library of Parts Lists, Mechanic's Guides and service information to assist the qualified mechanic with repair.

Fisher Engineering does not recommend repairs by other than our factory-trained outlets. Failure to use an authorized outlet could affect the warranty coverage on your snowplow.

# HARNESS DIAGRAMS

## 3-PORT, 2-PLUG SYSTEM – ALL BLADES

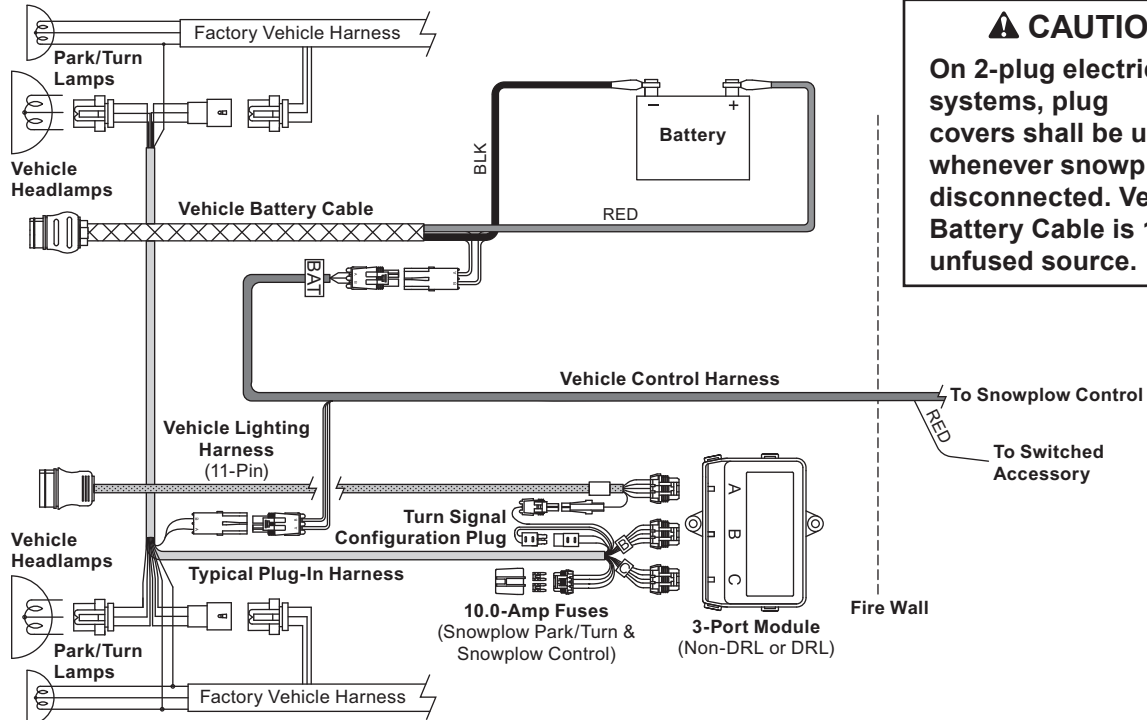

**⚠ CAUTION**  
On 2-plug electrical systems, plug covers shall be used whenever snowplow is disconnected. Vehicle Battery Cable is 12-volt unfused source.

# NOTES

---

---

---

---

---

---

---

---

---

---

---

---

---

---

---

---

---

---



Fisher Engineering  
50 Gordon Drive  
Rockland, ME 04841-2139  
www.fisherplows.com

 **A SUBSIDIARY OF DOUGLAS DYNAMICS, L.L.C.**



*This product conforms to EU Machinery Directive 2006/42/EC.*

Copyright © 2011 Douglas Dynamics, L.L.C. All rights reserved. This material may not be reproduced or copied, in whole or in part, in any printed, mechanical, electronic, film or other distribution and storage media, without the written consent of Fisher Engineering. Authorization to photocopy items for internal or personal use by Fisher Engineering outlets or snowplow owner is granted.

Fisher Engineering reserves the right under its product improvement policy to change construction or design details and furnish equipment when so altered without reference to illustrations or specifications used. Fisher Engineering or the vehicle manufacturer may require or recommend optional equipment for snow removal. Do not exceed vehicle ratings with a snowplow. This product is manufactured under the following U.S. patents: 5,353,530; 5,420,480; 5,638,618; 5,899,007; 6,253,470; 6,408,549; 6,944,978; 7,400,058; 7,430,821; 7,681,334; 7,737,576; 7,797,859; CAN patents 2,060,425; 2,184,922; 2,229,783; 2,356,036; and other patents pending. Fisher Engineering offers a limited warranty for all snowplows and accessories. See separately printed page for this important information. The following are registered (®) or unregistered (™) trademarks of Douglas Dynamics, L.L.C.: FISHER®, Fish-Stik®, HT Series™, Insta-Act®, INTENSIFIRE™, Minute Mount®, Minute Mount® 2, ProTube™, SECURITY GUARD™, SnoFoil®, STORM GUARD™, XBLADE™, XLS™, XtremeV™.