

LDK 5400

Triax Adapter for LDK 100 Series

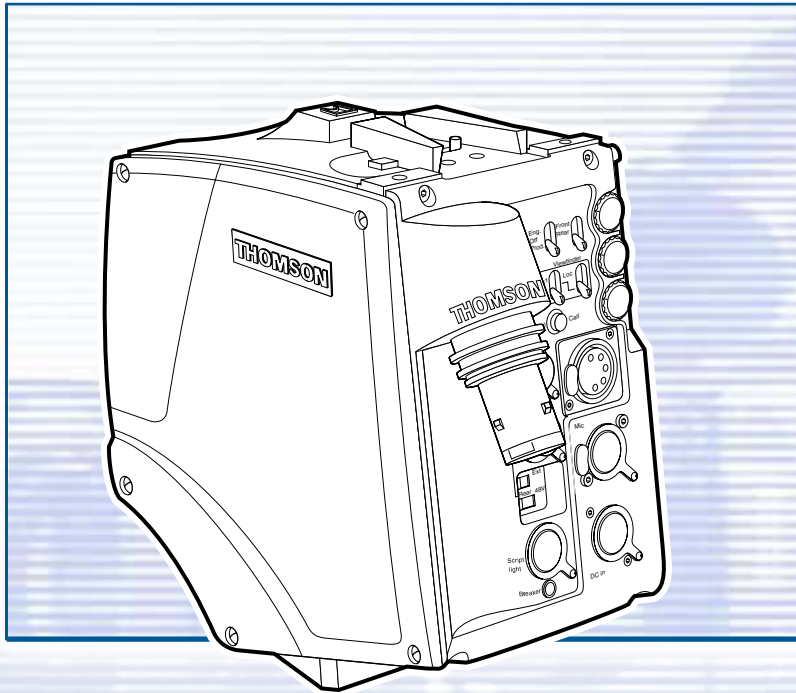
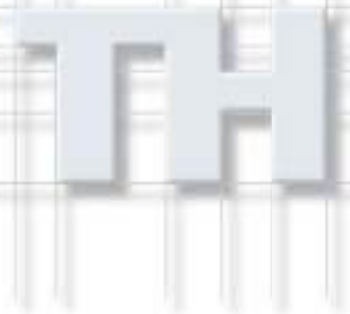

Technical Manual

3922 496 46791 St.03

Declaration of Conformity

We, Thomson Broadcast Solutions Nederland B.V., Kapittelweg 10, 4827 HG Breda, The Netherlands declare under our sole responsibility that this product is in compliance with the following standards:

- EN60065 : Safety
- EN55103-1 : EMC (Emission)
- EN55103-2 : EMC (Immunity)

following the provisions of:

- a. the Safety Directives 73/23/EEC and 93/68/EEC
- b. the EMC Directives 89/336/EEC and 93/68/EEC

FCC Class A Statement

This product generates, uses, and can radiate radio frequency energy and if not installed and used in accordance with the instructions, may cause interference to radio communications.

It has been tested and found to comply with the limits for a class A computing device pursuant to Subpart J of part 15 of FCC rules, which are designed to provide reasonable protection against such interference when operated in a commercial environment.

Operation of this product in a residential area is likely to cause interference in which case the user at his own expense will be required to take whatever measures may be required to correct the interference.

Copyright

Für diese Unterlage behalten wir uns alle Rechte vor (Gemäß DIN 34). Technische Änderungen im Zuge der Weiterentwicklung vorbehalten.

Copying of this document and giving it to others, and the use or communication of the contents thereof, are forbidden without express authority. Offenders are liable to the payment of damages. All rights are reserved in the event of the grant of a patent or the registration of a utility model or design. Liable to technical alterations in the course of further development.

Toute communication ou reproduction de ce document, toute exploitation ou communication de son contenu sont interdites, sauf autorisation expresse. Tout manquement à cette règle est illicite et expose son auteur au versement de dommages et intérêts. Tous nos droits sont réservés pour le cas de la délivrance d'un modèle d'utilité. Sous réserve de modification au cours de l'évolution technique.

**LDK 5400
Triax Adapter
Technical Manual**

Contents

About This Manual	ii		
Safety Instructions	1-1	Adjustments	4-1
Safety Summary	1-2	Introduction	4-2
Cautions and Warnings	1-2	Test Equipment	4-3
Earthing	1-3	Set-up Instructions	4-3
		White Pulse Gain	4-5
Installation	2-1	Encoder Board PAL	4-7
Packing/Unpacking	2-2	Encoder Board NTSC	4-13
Attaching an Camera	2-3		
Detaching an Camera	2-3	Wiring Diagrams	5-1
Hardware Customization	2-4	Wiring Diagram Triax adapter	5-2
Connectors and Cables	2-5	Wiring Diagram Motherboard Triax	5-5
Specifications	2-9		
		Mechanical Exploded Views	6-1
Replacements	3-1	Triax Adapter	6-2
Introduction	3-2	Triax Adapter Basic	6-3
Printed circuit boards	3-2		
		Parts Lists	7-1

About This Manual

Service policy

The LDK 5400 is a sophisticated triax adaptor containing state-of-the-art electronic components which are designed to provide long-life operation without the need for maintenance. With this in mind, the service policy of Thomson Multimedia Broadcast Solutions endeavours to ensure that help will be quickly on hand in the unlikely event of anything going wrong. The guiding principles of the Thomson Multimedia Broadcast Solutions first line maintenance philosophy are speed and cost effectiveness. First line maintenance is dedicated to keeping your camera operational, despite a fault, by module replacement and the replacement of minor mechanical parts by the user.

Purpose of this manual

The provision of correct information is the first step in ensuring the operational integrity of the camera. Information on the operation of the camera is to be found in the Operators's Manual.

This technical manual is an integral part of the service policy. It ensures that you will be able to install and set-up your camera to meet the requirements of your environment. This information on the installation of the triax adaptor is contained in Section 1 of the manual. The remaining sections of the manual provide first line service information so that suitably qualified service personnel can detect and repair faults, normally by module replacement.

Because of the complexity of some of the components, second line service can only be carried out at the specially equipped service centres and information concerning second line maintenance is not supplied in this manual.

Intended audience

The manual is intended as a guide to those with a working knowledge of camera systems and installation techniques. The first line detection and repair of faults requires a general knowledge of test and measurement techniques.

Structure of this manual

The manual is divided into 3 sections:

Section 1: Safety Information.

Contains important safety information and should be read before carrying out any work on the triax adaptor.

Section 2: Installation.

Gives instructions on the integration of the triax adaptor into the operating environment and the customization of certain hardware functions

Section 3: Replacements.

Gives information on the replacement of components at first line level.

Section 4: Adjustments.

Contains the adjustment procedures to be followed to obtain the best performance from the triax adaptor.

Section 5: Wiring Diagrams

Contains the wiring diagrams of the triax adaptor.

Section 6: Exploded Views

Contains the Exploded Views of the triax adaptor.

Section 7: Mechanical Partslist

Contains the Mechanical Partslist diagrams of the triax adaptor.

Identification and Status

To indicate the status of a drawing, a box with the numbers 0 to 9 is shown in the bottom-right of the drawing. The number that is crossed-out is the status number of the drawing. For example, in the illustration below, the status is 1.

0	1	2	3	4
5	6	7	8	9

A sticker is used on the units themselves to identify them and to indicate their status. For example, in the illustration below, the top line is the 12-digit number that identifies the unit type.

3922	406	88991
00121107	00	01

The first four digits of the number on the second line represent a date code (year, week); the next four digits represent the serial number for that week.

The number in the grey area indicates the status of the unit. The last two digits represent the number that will be given to the next status. However, if these two digits are contained in a box, then this is the current status. For example, in the illustration above, the current status of the unit is 01.

Line 1	3922 407 00000
Line 2	123456AA0101
Line 3	VR/0123456789

Line 1

This is the code number of the printed circuit board assy. (PCB)

Line 2

This is the serial number of the PCB. The first 6 digits and the 2 letters are for internal use. The last four digits represent the date of the manufacturing: wwyy.

Example:

123456AA1402 means the PCB is manufactured in week 14 of the year 2002.

Line 3

This is the status of the PCB.

The digit after the first slash is the status. If there is no number before the slash, it means that the status is less than 10, a 1 before the slash means the status is between 10 and 19, a 2 before the slash means between 20 and 29 etc.

Example:

- VR4567891012 means status 4

- VR3/78901234 means status 37.

Example of LDK number:

LDK 4501/01 means 8926 **450 10101**

LDK 4500/00 means 8926 **450 00001**

Numbers of printed circuit board assy

- 3922 406 xxxxx or 3922 407 xxxxx

Number (screened in PCB layout) of printed circuit board assy: 3922 411xxxxx. (not a sparepart)

Section 1

Safety Instructions

This section outlines the precautions that must be taken into account when using the LDK 100 camera head.

Contents

Safety Summary	1-2	Earthing	1-3
Cautions and Warnings	1-2		

This information is intended as a guide for trained and qualified personnel who are aware of the dangers involved in handling potentially hazardous electrical/electronic equipment. It is not intended to contain a complete list of all safety precautions which should be observed by personnel in using this or other electronic equipment.

The installation, maintenance and service of this equipment involves risks both to personnel and equipment and must be performed only by qualified personnel exercising due care.

Personnel engaged in the installation, operation, maintenance or servicing of this equipment are urged to become familiar with First Aid theory and practices.

During installation and operation of this equipment, local building safety and fire protection standards must be observed.

Before connecting the equipment to the power supply of the installation, the proper functioning of the protective earth lead of the installation needs to be verified.

Whenever it is likely that safe operation is impaired, the apparatus must be made inoperative and secured against any unintended operation. The appropriate servicing authority must then be informed. For example, safety is likely to be impaired if the apparatus fails to perform the intended function or shows visible damage.

This product has been designed and tested according to EN60065.

When performing service, be sure to read and comply with the warning and caution notices appearing in the manuals. Warnings indicate danger that requires correct procedures or practices to prevent death or injury to personnel. Cautions indicate procedures or practices that should be followed to prevent damage or destruction to equipment or property.

WARNING

THE CURRENT AND VOLTAGES PRESENT IN THIS EQUIPMENT ARE DANGEROUS. ALL PERSONNEL MUST AT ALL TIMES FOLLOW THE SAFETY REGULATIONS.

ALWAYS DISCONNECT POWER BEFORE REMOVING COVERS OR PANELS.

ALWAYS DISCHARGE HIGH VOLTAGE POINTS BEFORE SERVICING.

NEVER MAKE INTERNAL ADJUSTMENTS, PERFORM MAINTENANCE OR SERVICE WHEN ALONE OR WHEN FATIGUED.

IN CASE OF AN EMERGENCY ENSURE THAT THE POWER IS DISCONNECTED.

ANY INTERRUPTION OF THE PROTECTION CONDUCTOR INSIDE OR OUTSIDE THE APPARATUS, OR DISCONNECTION OF THE PROTECTIVE EARTH TERMINAL, IS LIKELY TO MAKE THE APPARATUS DANGEROUS. INTENTIONAL INTERRUPTION IS PROHIBITED.

FOR SAFETY REASONS THE CPU MUST BE MOUNTED IN A 19-inch RACK WHICH HAS SAFETY COVERS ACCORDING TO IEC65.

WHEN TWO CPUs ARE MOUNTED ABOVE EACH OTHER THE MINIMUM DISTANCE BETWEEN THEM MUST BE 50MM OR THE RACK MUST BE FORCE-AIR COOLED.

USE ONLY FUSES OF THE TYPE AND RATING SPECIFIED.

CAUTION

To prevent risk of overheating, ventilate the product correctly.

Connect the product only to a power source with the specified voltage rating.





Only connect a Triax cable from the LDK 6 camera family to an LDK 6 CPU. Never connect it to any other base station.

Never connect the Triax cable from a camera to a CPU of a different family; never connect the LDK family to the TTV family.

Do not allow system ground currents to exceed 1.5A in the outer shield of the triax cable or 0.2A in other cable shields.

It is strictly prohibited to short circuit the inner and outer shields of a triax cable used to connect a camera to a base station.

Earthing

Symbol	Colour	Explanation
	Red	High voltage terminal at which a voltage, with respect to an other terminal, exists or may be adjusted to 1000V or more.
	Yellow/Black	Live part.
	Yellow/Black	This marking indicates that the operator must refer to an explanation in the Instruction Manual, or that a specific component must be replaced by the component specified in the documentation for safety reasons.
	White/Black	Protective earth (ground) terminal.



Cathode ray tubes

Components marked  on the circuit diagram are critical for safety and include those specified to comply with X-ray emission standards for units using cathode ray tubes and those specified for compliance with various regulations regarding spurious radiation emission.

When servicing units that use cathode ray tubes (CRTs), the cathode ray tubes themselves, the high voltage circuits and related circuits are specifically chosen so that they comply with recognized codes pertaining to X-ray emission.

Consequently, when servicing, replace the cathode ray tubes and other parts with specified parts only. Do not attempt to modify these circuits as any unauthorized modification can increase the high voltage value and cause X-ray emission from the cathode ray tube.

Handle the cathode ray tube only when wearing shatterproof goggles and after discharging the high voltage completely.

The rear of a CPU has two separate screw terminals for protective earth  (PE) and video earth  (VE).

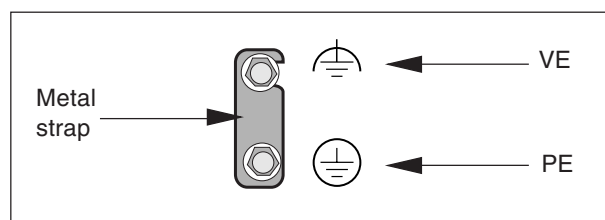

These are normally connected by a metal strap. The protective earth terminal is internally connected to the protective earth conductor of the power cable. If required, the central earth connection wire of the studio can be connected to terminal PE.

In normal circumstances the connection between the protective earth and the video earth should not be broken.

The metal strap may be removed only if the studio (or OB van) is equipped with separate protective and video earth systems. Under these circumstances the video earth terminal must be connected to the central functional earth potential (video earth) of the studio. This earth potential should have functional protective and noiseless earth (FPE) qualities as stated in the VDE regulation 0800/part2. A low impedance interconnection of both earth conductors must be provided at the central studio earthing point.

WARNING

THE UNIT MUST ALWAYS BE CONNECTED TO PROTECTIVE EARTH.

Mains Lead Wiring for UK Users

The wires in the mains lead are coloured in accordance with the following code:

GREEN AND YELLOW	-	EARTH
BLUE	-	NEUTRAL
BROWN	-	LIVE

As the colours of the wires in the mains lead of this apparatus may not correspond with the coloured markings identifying the terminals in your plug proceed as follows:

- The wire coloured GREEN AND YELLOW must be connected to the terminal on the plug marked with the letter E or by the safety earth symbol  or coloured GREEN or GREEN AND YELLOW.
- The wire coloured BROWN must be connected to the terminal marked with the letter L or coloured RED.
- The wire coloured BLUE must be connected to the terminal marked with the letter N or coloured BLACK.

Ensure that your equipment is connected correctly - if you are in any doubt consult a qualified electrician.

Section 2

Installation

This section provides information which is relevant when the adapter is to be used for the first time. Packing and unpacking instructions together with information on the integration of the adapter into your studio system are provided. The procedures for the customization of certain hardware functions and connector information is also provided.

Contents

Packing/Unpacking	2-2	Hardware Customization	2-4
Attaching an Camera	2-3	Connectors and Cables	2-5
Detaching an Camera	2-3	Specifications	2-9

Packing/Unpacking

Inspect the shipping container for evidence of damage immediately after receipt. If the shipping container or cushioning material is damaged, it should be kept until the contents of the shipment have been checked for completeness and the units have been checked mechanically and electrically.

The shipping container should be placed upright and opened from the top. Remove the cushioning material and lift out the contents.

The contents of the shipment should be checked against the packing list. If the contents are incomplete, if there is mechanical damage or defect, or if the units do not perform correctly when unpacked, notify your Thomson Multimedia Broadcast Solutions sales or service centre within eight days. If the shipping container shows signs of damage or stress, notify the carrier as well.

If a unit is being returned to Thomson Multimedia Broadcast Solutions for servicing, try to use the containers and materials of the original packaging. Attach a tag indicating the type of service required, return address, model number, full serial number and the return number which will be supplied by your Thomson Multimedia Broadcast Solutions service centre.

If the original packing can no longer be used, the following general instructions should be used for repacking with commercially available materials:

- a. Wrap unit in heavy paper or plastic.
- b. Use strong shipping container.
- c. Use a layer of shock-absorbing material around all sides of the unit to provide firm cushioning and prevent movement inside container.
- d. Seal shipping container securely.
- e. Mark shipping container FRAGILE to ensure careful handling.

Attaching an Camera

The LDK 5400 Adapter is a unit that can be used with the LDK 100 Camera head. To attach an adapter to the camera head proceed as follow:

Caution

Be extremely careful with the connectors between the camera head and the adapter. Do not allow the guide pins to damage the pins of the connector.

Caution

Follow these steps in the order given. Tightening the screws in the wrong order could result in mechanical damage to the camera.

- Using the rail **1** on the bottom of the camera head as a guide, fit the guide pins **2** on either side of the connector and the guide pin **3** at the top rear of the camera head into the corresponding slots of the adapter.
- First, tighten the two horizontal screws **4** on the top of camera.
- Next, tighten the two horizontal screws **5** at the front of the camera.
- Lastly, tighten the vertical screw **6** in the handle of the camera.

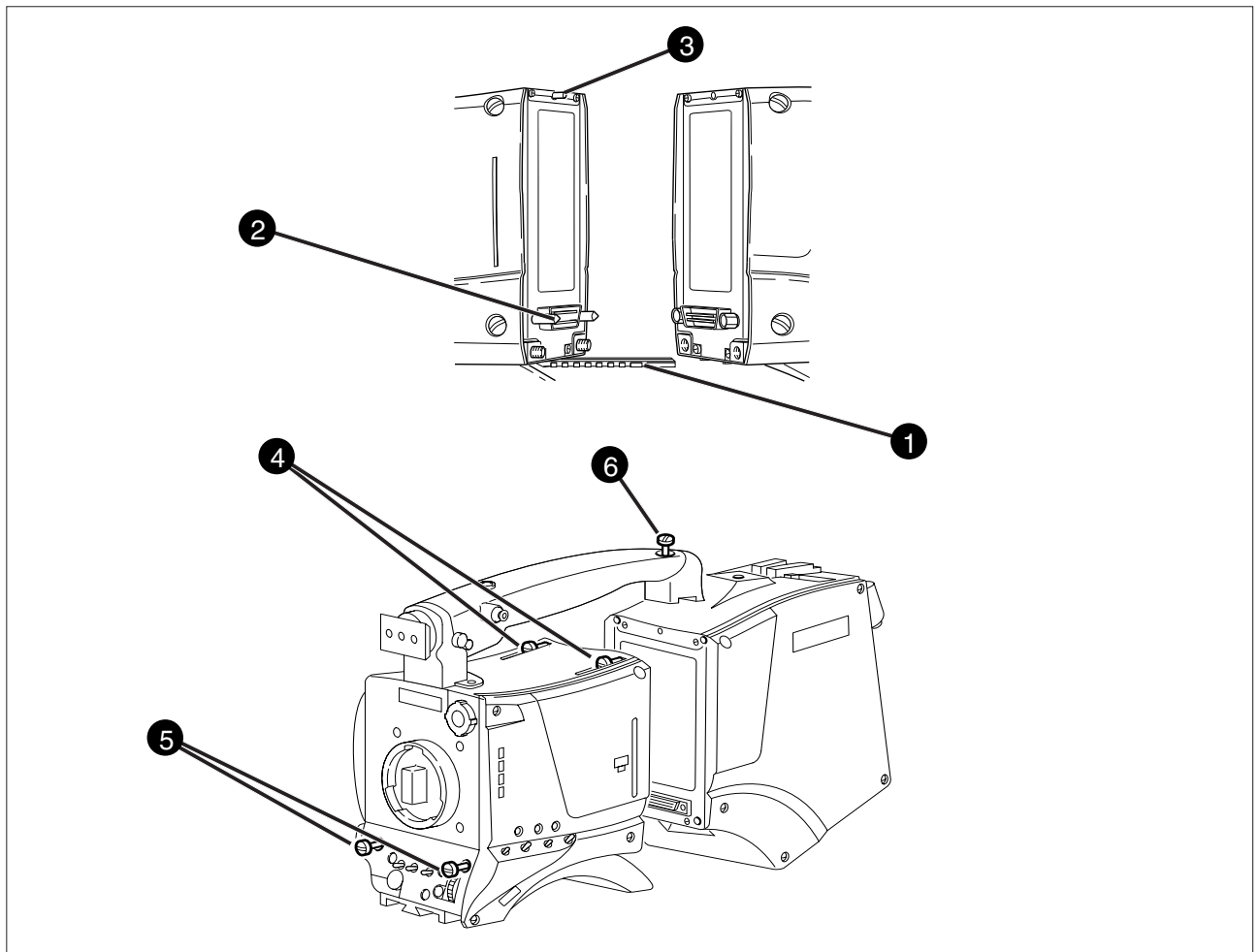

Detaching an Camera

To detach an adapter from the camera head follow the steps for attaching it in the reverse order.

Caution

Loosening the screws in the wrong order could result in mechanical damage to the camera.

Note

The procedure is given for the Triax adapter LDK 5400. Follow the same procedure for other adapters.

Hardware Customization

The camera is delivered in a ready-to-use state, however, there are occasions when it might be necessary to re-adjust some functions after, for example, fitting a new board.

A large number of functions can be set-up using the control facilities of the menu system. In addition to this software set-up there are some functions which can be selected or adjusted internally in the camera.

Refer to the next chapters for instructions.

Location of boards

Unscrew the five screws on the left side panel and swing down the cover.

- ① Data board
- ② Encoder board (**Option**)*
- ③ Video Mux Ext-Rec board
- ④ Audio/Intercom TX-Rec board
- ⑤ Audio/Intercom LF board
- ⑥ Power board
- ⑦ Triax backpanel

* LDK 5405/00 Encoder PAL
LDK 5405/50 Encoder NTSC

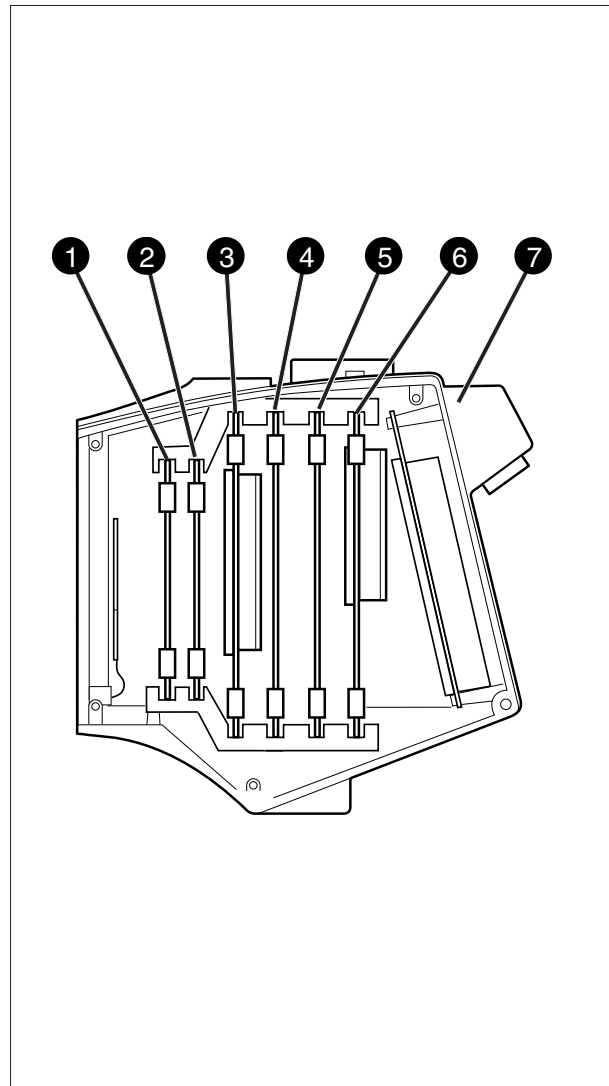
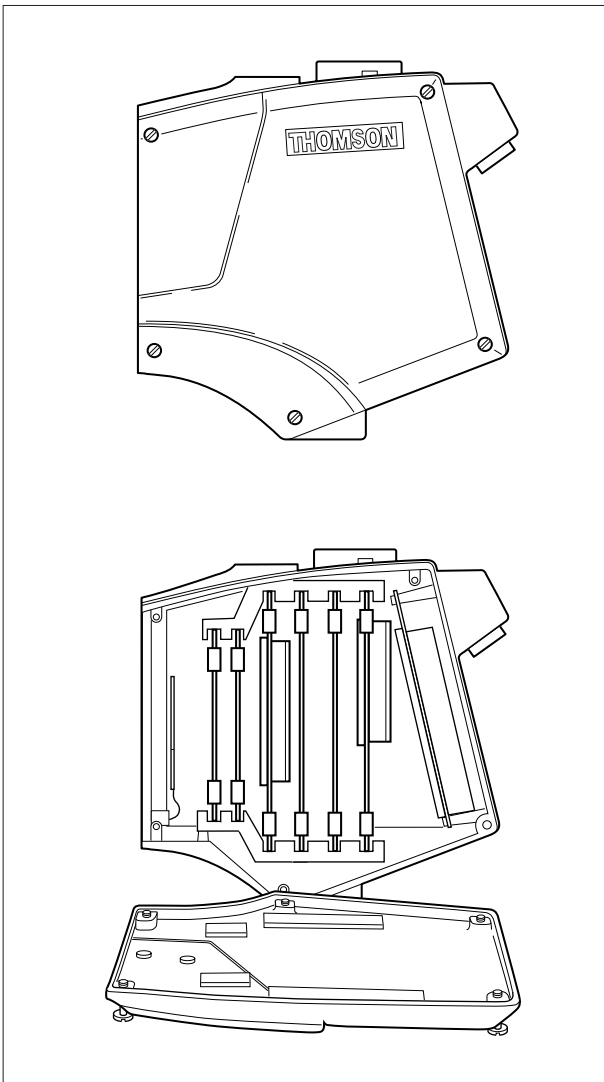

Connectors and Cables

Triax connector

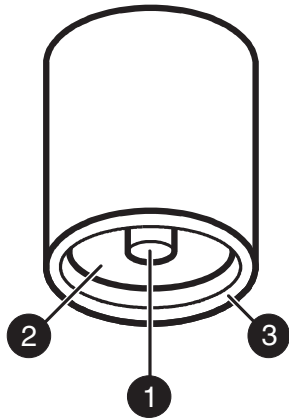

3-pin; panel view
Cable part: see page 2-7

Fischer

- | | |
|------------------|-----------------|
| 1. Inner pin: | Signals + power |
| 2. Inner shield: | Return |
| 3. Outer shield: | Camera housing |

Trilock

- | | |
|------------------|-----------------|
| 1. Inner pin: | Signals + power |
| 2. Inner shield: | Return |
| 3. Outer shield: | Camera housing |

ARD

- | | |
|------------------|-----------------|
| 1. Inner pin: | Signals + power |
| 2. Inner shield: | Return |
| 3. Outer shield: | Camera housing |
- part number 3922 040 01492

LEMO/ LEMO BBC/ LEMO3T

- | | |
|------------------|-----------------|
| 1. Inner pin: | Signals + power |
| 2. Inner shield: | Return |
| 3. Outer shield: | Camera housing |

Script light connector

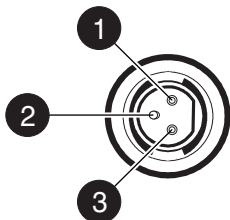

Fischer 3-pin female; panel view
Cable part: 2432 026 00274

- | | |
|----|-------------------------------|
| 1. | +12V (Maximum Dissipation 3W) |
| 2. | Power Return |
| 3. | Shield |

Power input connector

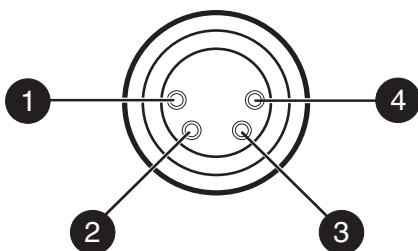

XLR4-pin male; panel view
Cable part: 5322 267 41043

- | | |
|----|----------------|
| 1. | Gnd |
| 2. | n.c. |
| 3. | n.c. |
| 4. | +10,5V.....17V |

Camera headset connector

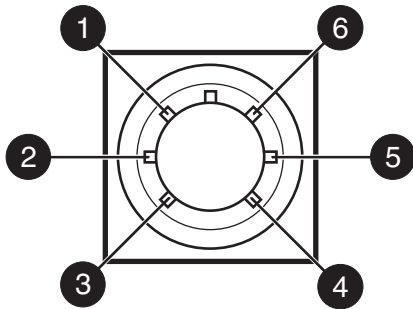

1. Telephone left
2. Not connected
3. Microphone
4. Microphone return
5. Telephone right
6. Telephone return

Tuchel 6-pin female; panel view
Cable part: 5322 265 30365

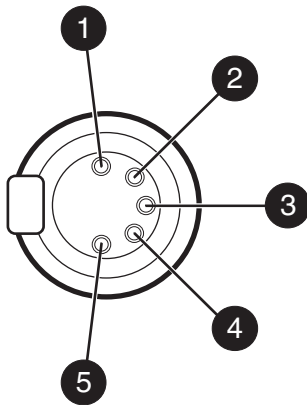

1. Microphone return
2. Microphone
3. Telephone return
4. Telephone left
5. Telephone right

- Microphone level -58dBm/-20dBm switchable
- Microphone impedance 200 ohm
- Telephone level +6dBm nominal
- Telephone output impedance <10 ohm

XLR 5-pin female; panel view
Cable part: 2422 026 03393

Audio microphone connectors

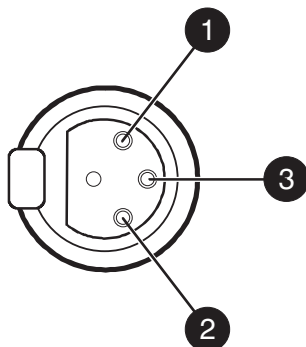

1. Audio Screen
2. Audio In
3. Audio Return

- Microphone impedance > 200 ohm
- Sensitivity remote controlled via base station:
range: -70 to -28 dBm
maximum input = -6 dBm
- Signal at pin 2 of audio input is in phase with
signal at pin 2 of audio output on Base Station

XLR 3-pin female; panel view
Cable part 5322 267 41055

Panel Connector assy

PanelConnector	Type		Part number	Cable part number
Triax	3-pin	Fischer	5322 218 11775	**
Triax	3-pin	Trilock	5322 218 11778	--
Triax	3-pin	ARD	5322 218 11776	--
Triax	3-pin	Lemo	5322 218 11777	--
Triax	3-pin	Lemo BBC	5322 218 11774	--
Triax	3-pin	Lemo 3T	3922 407 34471	--
Headset	6-pin	Tuchel female	5322 265 11108	--
Headset	5-pin	XLR female	5322 265 11107	--

Cable partnr: LDK8200/ (only Fisher connectors)**

/02 for 8mm cable female /00 for 8mm cable male
/05 for 11mm cable female /10 for 11mm cable male
/10 for 14mm cable female /20 for 14mm cable male

Docking connector Adapter

A row	name	B row	name	C row	name	D row	name
1	lon data	1	lon data N	1	GND	1	+ batt
2	SDA_C	2	SCL_C	2	GND	2	+ batt
3	INTN_C	3	audio indication	3	GND	3	+ batt
4	AB batt sense	4	batt sense	4	GND	4	+ batt
5	adpt id 0	5	adpt id 1	5	GND	5	+ batt
6	adpt id 2	6	adpt id 3	6	GND	6	+ batt
7	cam id 0	7	cam id 1	7	GND	7	+ batt
8	48 kHz	8	PIP	8	GND	8	+ batt
9	sync	9	blanking	9	GND	9	
10	white pulse 1	10	white pulse 2	10	GND	10	
11	colour framing	11	frame reset	11	GND	11	
12	BS_TDA	12	H lock	12	GND	12	
13	PIP video	13	PIP video ret	13	GND	13	
14	BS_TDV	14	BS_TMS	14	GND	14	
15	adapter vf video	15	adapter vf video ret	15	GND	15	
16	BS_TCK	16	BS_TRSTN	16	GND	16	GND
17	ext video	17	ext video ret	17	GND	17	GND
18	-5V	18	-5V	18	-5V	18	-5V
19	+5V	19	+5V	19	+5V	19	+5V
20	+3.3V	20	+3.3V	20	+3.3V	20	+3.3V
21	+5VD	21	+5VD	21	+5VD	21	+5VD
22	shield	22	shield s	22	GND	22	GND
23	mic X	23	mic Xs	23	GND	23	GND
24	mic Y	24	mic Ys	24	GND	24	
25	audio level	25	audio level ref	25	GND	25	
26	power switch	26		26	GND	26	
27	R	27	R ret	27	GND	27	
28	YC clock	28	YC clock ret	28	GND	28	
29	G	29	G ret	29	GND	29	
30	YC9	30	YC9 ret	30	GND	30	
31	B	31	B ret	31	GND	31	
32	YC8	32	YC8 ret	32	GND	32	
33	YC7	33	YC7 ret	33	GND	33	
34	YC6	34	YC6 ret	34	GND	34	housing
35	YC5	35	YC5 ret	35	GND	35	housing
36	YC4	36	YC4 ret	36	GND	36	housing
37	YC3	37	YC3 ret	37	n.c.	37	
38	YC2	38	YC2 ret	38	n.c.	38	
39	YC1	39	YC1 ret	39	-80V	39	
40	YC0	40	YC0 ret	40	-80V	40	

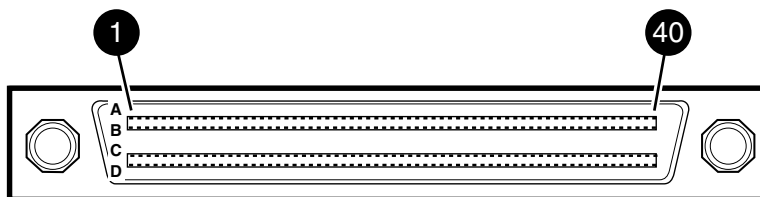

160-pin female; panel view

Specifications

LDK 100 (with Triax adapter)

General data

Power requirements triax powered or 12V dc
Power consumption 20 W (Head + VF)

Operating temperatures
-20 to +45°C (-4 to +113°F)
Storage temperatures
-20 to +60°C (-4 to +140°F)

Weight (approx.)
4.9 kg (14.1 lb) incl. 1.5-inch VF and triax adapter

Triax cable length
2,400m (7,875 ft) max. with 16mm (0.63") cable

Camera section

Pick-up device
3 x 2/3-inch Philips Frame Transfer Sensors or
3 x 2/3-inch switchable DPM Sensors

Picture elements
NTSC: 1000(h) x 498(v)
PAL: 1000(h) x 594(v)

Digital quantization
12 bits A/d

Digital signal processing
18 MHz and 36 MHz, 24 bits accuracy

Sensitivity
2000 lux (186 ft cd) at F9.0 reflectance 89.9%

Minimum illumination
Approx. 1 lux at F 1.4 and +36 dB gain

Exposure control
Down to 1/1000

Clean scanning
NTSC: between 61.1 and 151.0 Hz
PAL: between 51.0 and 103.0 Hz

Optical system
F1.4 with quartz filter

Optical filters
Clear; 1/4 ND, 1/16 ND, 1/64 ND

Modulation depth
>70% at 5Mhz

S/N ratio
Typical: 60 dB PAL and 62 dB NTSC

Registration
<25 ns (0.05%) in all zones, without lens

Dynamic range
>600%

Gain
-6dB to +36dB in 3dB steps (user defined presets)

Inputs

Front mic. 1 x XLR 3, balanced, +48V
Mic. 1 x XLR 3, balanced, +48V
DC 12V XLR 4
Control input 9-pin, RS232 compatible

Outputs

Triax Option: Fischer/ARD/Lemo/
Trilock
Lens 12p
Viewfinder 20p
Cameraman headset Option: XLR5/Tuchel
Video (CVBS) out Option: 1 Vpp; 75 Ohm; BNC
Monitor (Y) 1 Vpp; 75 Ohm; BNC
Scriptlight power 3p; 12V

Connectors Base Station LDK 4053

Triax Option: Fischer/ARD/Lemo/
Trilock
Power AC-power connector
Audio XLR 3
Intercom ENG/PROD/PROG
via 15p D-connector
Call/Tally R/Y via 15p D-conn.
1 Vpp; 75 Ohm; BNC
RGB 700 mVpp; 75 Ohm; BNC
Y, R-Y, B-Y 700, 525, 525 mVpp; 75 Ohm;
BNC
PXM 1 Vpp; 75 Ohm; BNC
WFM 1 Vpp; 75 Ohm; BNC
Serial Digital (2x) 270 MB/s
Ext 1 Option: 800 mV; 75 Ohm; BNC
Genlock in 1 Vpp; 75 Ohm; BNC
Ext. Camera Control 4p DATA

These typical specifications are valid for PAL and NTSC systems and are subject to change without notice

Section Replacements

This section gives information on the procedures to follow when replacing printed circuit boards and mechanical components at first line level.

Contents

Introduction	3-2	Printed circuit boards	3-2
--------------------	-----	------------------------------	-----

The instructions given in this section are restricted to those modules which can be replaced at the first line level. After a printed circuit board has been replaced it is sometimes necessary to carry out adjustments to match the new boards to your camera and so maintain the performance levels. The relevant adjustment procedures are referenced in section 3. The procedures for removing the modules should be followed in reverse order when remounting the units.

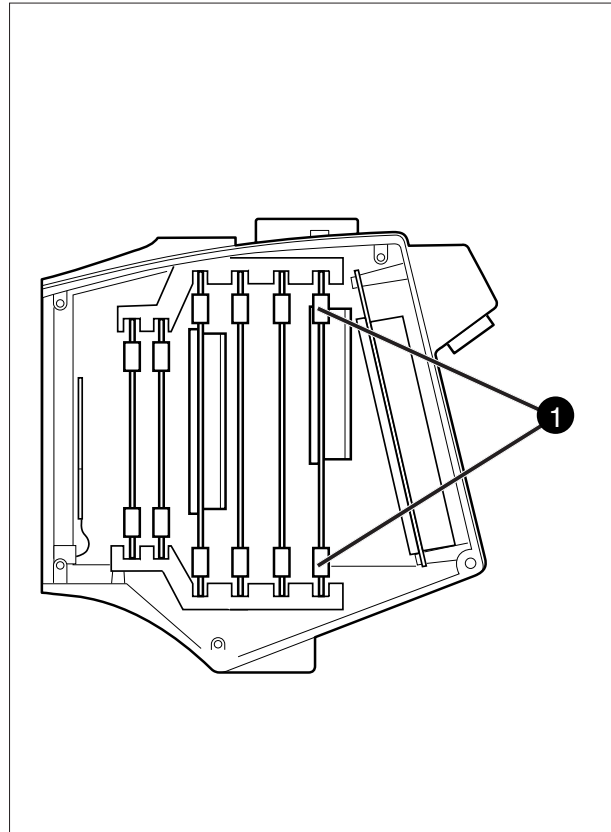

- a. Remove left cover. (see section 1)
- b. Turn the print ejector ❶ of the printed circuit board on the top upwards and under downwards.
- c. Pull horizontally on this covers to free the board from its connector and slide it clear of the camera.

Section 4

Adjustments

This section contains the adjustment procedures to be followed to obtain the best performance from the camera. These procedures need only be used if, following a module replacement, the camera does not perform according to specifications.

Contents

Introduction	4-2	White Pulse Gain	4-5
Test Equipment	4-3	Encoder Board PAL	4-7
Set-up Instructions	4-3	Encoder Board NTSC	4-13

Introduction

This unit is factory tested and adjusted for operational use. Under normal circumstances, the internal automatic calibration procedures do not need to be started and the internal potentiometers do not need to be adjusted.

The only situation that might require some realignment of the adapter is when a printed circuit board has been replaced.

If the Video Mux. board is replaced, readjust the white pulse amplitude.

If the Encoder board is replaced, follow the procedure for its readjustment. The encoder timing adjustments can be carried out via the menu system.

If it is discovered that the unit is misaligned, the following procedures are given as a guide for competent service personnel, who have a thorough knowledge of the camera and have the use of calibrated equipment, to realign the unit.

If no improvement can be achieved or an adjustment is out of range, please contact your local supplier or the nearest Thomson Multimedia Broadcast Solutions Service Centre.

The adjustment procedures are designed as separate units. Within a numbered procedure do not change the position of switches or jumpers unless instructed to do so in the procedure.

These adjustment procedures are for the Triax Adapter. However, for practical purposes the Triax Adapter is used together with the camera head to facilitate some measurements.

The following is a list of equipment required to carry out the adjustment procedure:

- Set of board extenders LDK 5820/01
- Oscilloscope (with cursor measurement)
- Waveform monitor

Before carrying out any adjustments the following steps are recommended:

- Attach the adapter to the camera.
- Install the camera on a tripod.
- Attach the lens and the necessary cables.
- Allow the camera to warm-up.

CAUTION:

Do not attempt to improve camera performance by adjusting individual potentiometers, jumpers or switches as this may lead to complete misalignment of the camera.

CAUTION:

Do not realign individual potentiometers, jumpers or switches not mentioned in this chapter or earlier in this manual. These adjustment points are for factory use only.

CAUTION:

Switch off the power supply to the camera before removing or replacing printed circuit boards.

White Pulse Gain

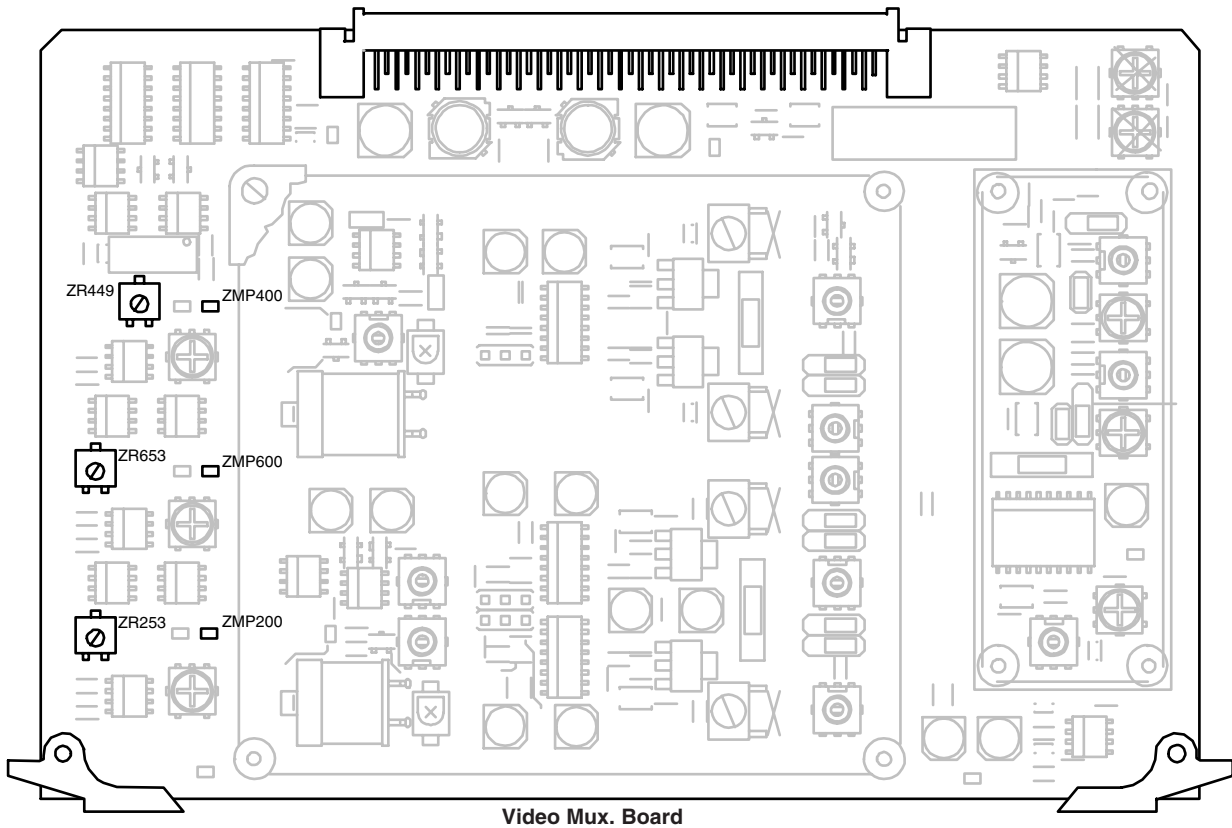

Extender Board

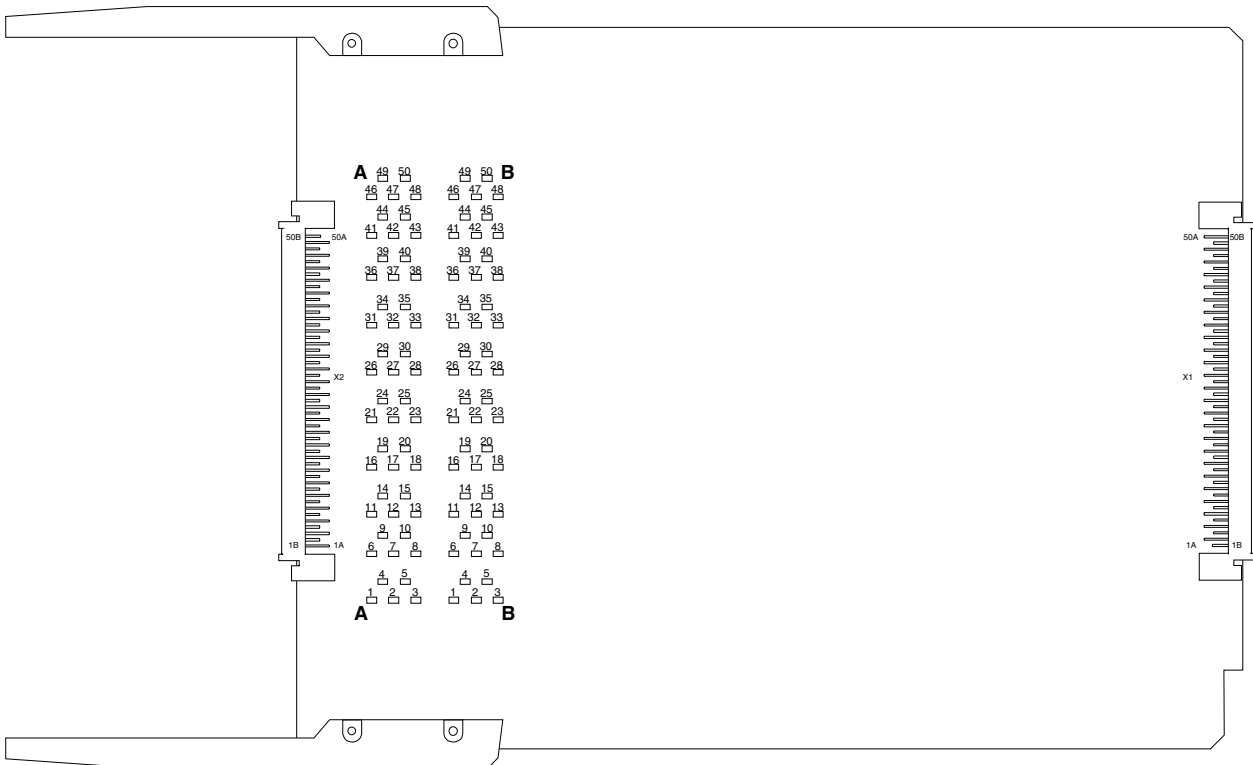

White Pulse Gain

White pulse amplitude

1. Switch off power. Place Video Mux.board on service extender. Switch on power.
2. Connect adapter to a base station and switch on colour bar.
3. Adjust the white pulse in line 10 (PAL), in line 13 (NTSC) for the R-Mux output to equal the video level.

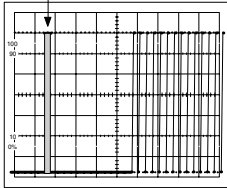
Measure at:	Adjust with:	Required result:	Correct:
ZMP200	ZR253	700mV	

4. Adjust video level to equal the white pulse in line 10 (PAL), in line 13 (NTSC) for the G-Mux output.

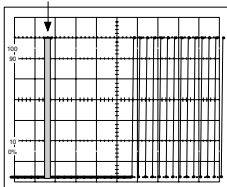
Measure at:	Adjust with:	Required result:	Correct:
ZMP400	ZR449	700mV	

5. Adjust the white pulse in line 11 (PAL), in line 14 (NTSC) for the B-Mux output to equal the video level.

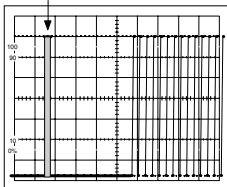
Measure at:	Adjust with:	Required result:	Correct:
ZMP600	ZR653	700mV	

Encoder Board PAL

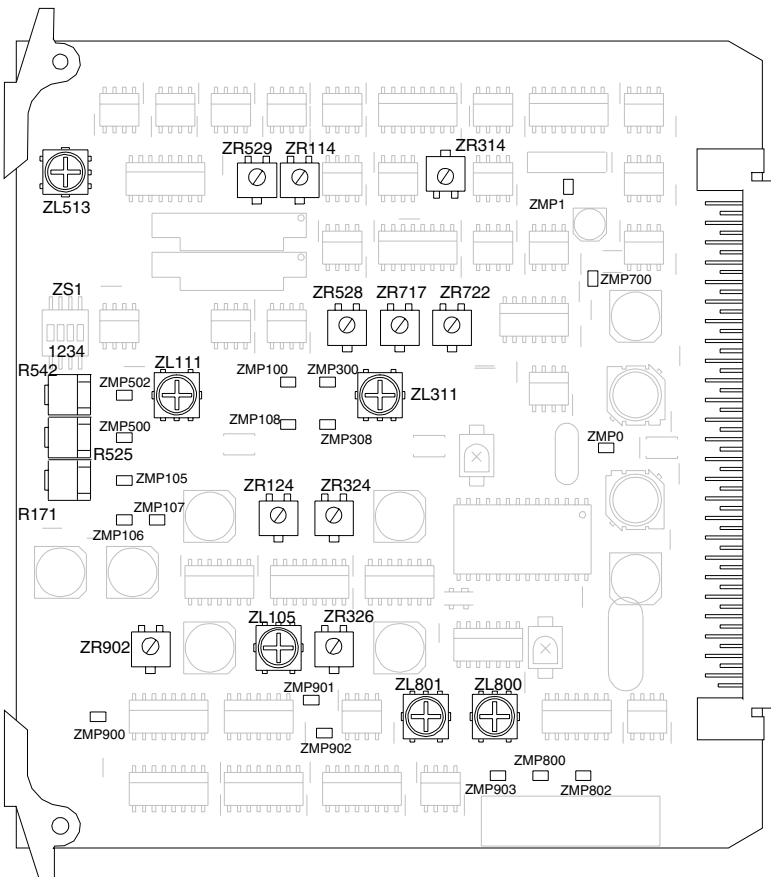
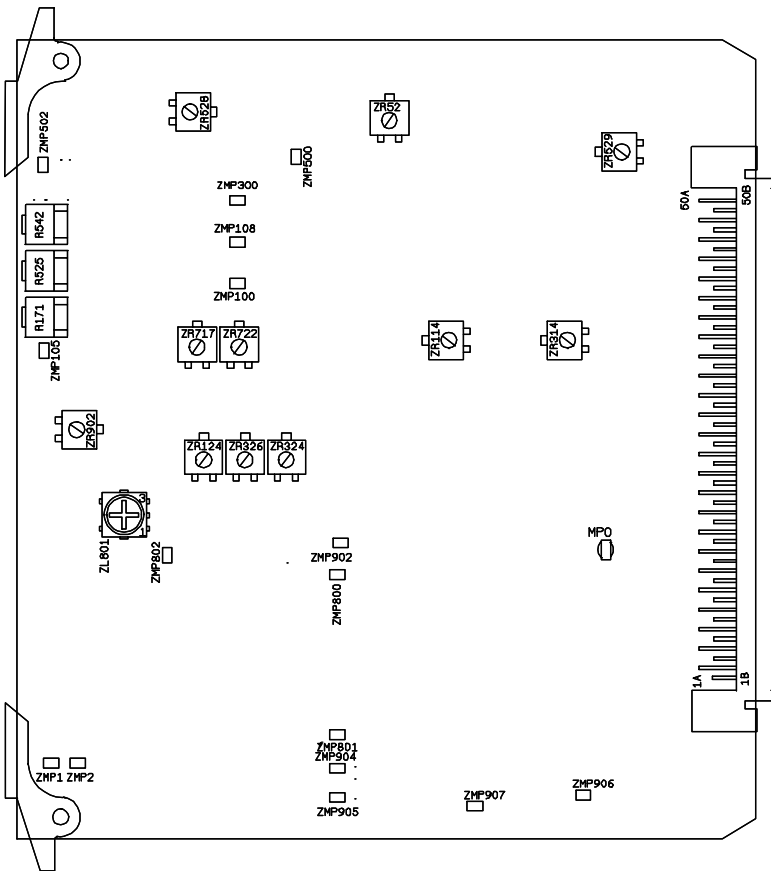

Encoder Board PAL

Set-up

1. Switch off power. Place encoder board on service extender. Genlock camera with black burst signal. Switch on power.
2. Connect oscilloscope via a vectorscope terminated with 75 Ohm to the CVBS output.
3. Switch on colour bar.

Black balance

4. Turn chroma potentiometer R171 on encoder board fully clockwise (max. chroma).
5. Adjust the I and Q balance potentiometers for minimum unbalance in black.

Measure at:	Adjust with:	Required result:	
CVBS out	ZR124 ZR324	Smallest possible dot in centre of vectorscope	

CVBS offset

6. Adjust the CVBS offset potentiometer to place the black bar at 0 Vdc.

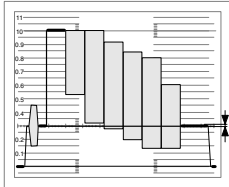
Measure at:	Adjust with:	Required result:	Correct:
CVBS out	ZR529	Black bar = 0 Vdc	

CVBS amplitude

7. Adjust the CVBS gain potentiometer to obtain an output amplitude of 700mV.

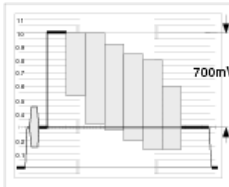
Measure at:	Adjust with:	Required result:	Correct:
CVBS out	R542	700mV	

R-Y amplitude

8. Adjust the R-Y potentiometer to obtain an output amplitude of 1050 mV

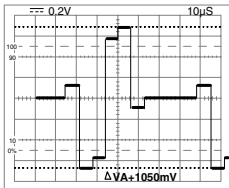
Measure at:	Adjust with:	Required result:	Correct:
X21-8A	R314	1050mV	

Encoder Board PAL

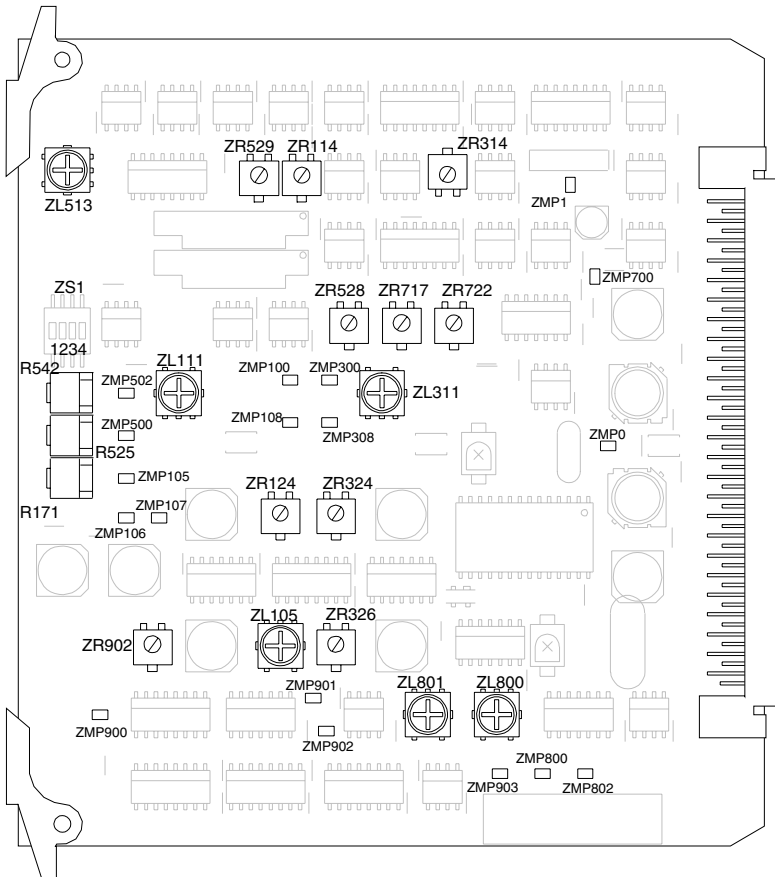
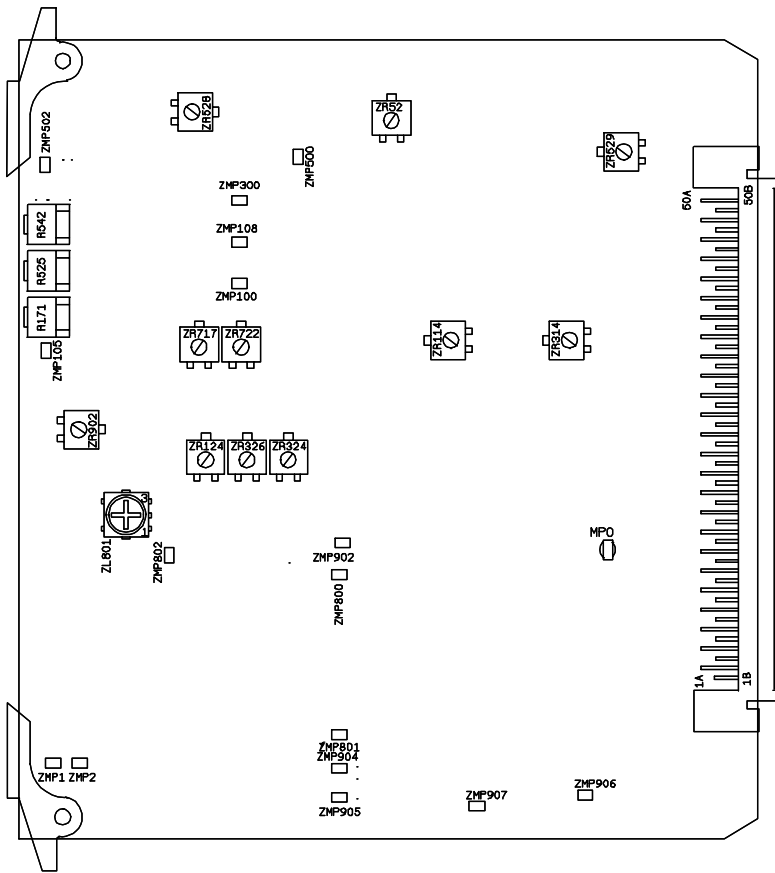

Encoder Board PAL

B-Y amplitude

9. Adjust the B-Y gain potentiometer to obtain an output amplitude of 1050mV.

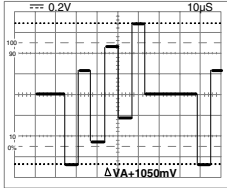
Measure at:	Adjust with:	Required result:	Correct:
X21-11A	ZR114	1050mV	

BURST ADJUSTMENTS

Burst phase

10. Measure in second quadrant of vectorscope.
Adjust the input sensitivity potentiometer of the vectorscope so the burst vectors just touch the circle graticule.
11. Adjust the burst phase potentiometer for 90° phase output.

Measure at:	Adjust with:	Required result:	Correct:
CVBS out	ZR722		

Burst amplitude

12. Adjust the burst amplitude potentiometer to obtain a burst amplitude of 300mV.

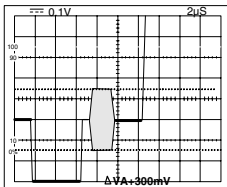
Measure at:	Adjust with:	Required result:	Correct:
CVBS out	ZR717	300mV	

Sc-H phase relationship

13. Switch vectorscope to internal synchronisation.
14. Adjust Sc-H phase potentiometer for 180°.

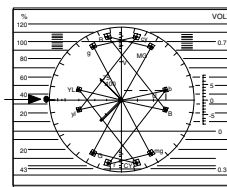
Measure at:	Adjust with:	Required result:	Correct:
CVBS out	ZR902		

Encoder Board PAL

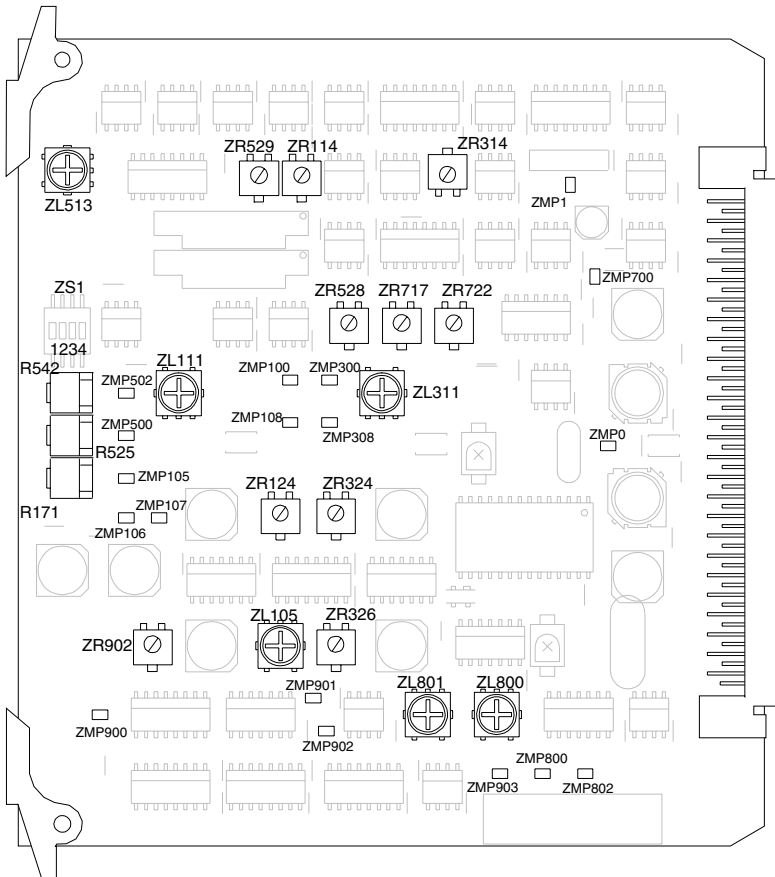
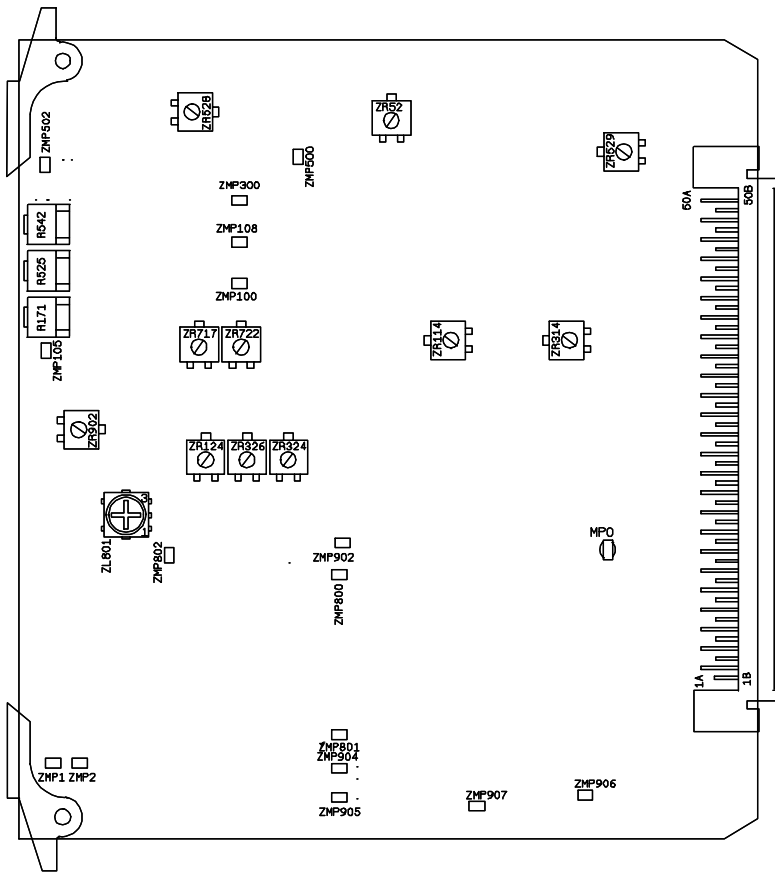

Encoder Board PAL

Sync amplitude

15. Adjust the sync, amplitude potentiometer fto obtain a sync. ampliature of 300mV.

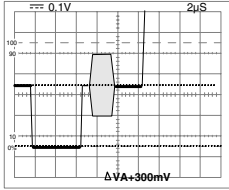
Measure at:	Adjust with:	Required result:	Correct:
CVBS out	ZR525	300mV	

Y offset

16. Adjust the Y offset potentiometer to place the black bar at the 0Vdc level.

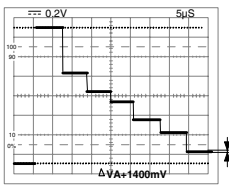
Measure at:	Adjust with:	Required result:	Correct:
X21-14A	ZR52	Black bar = 0 Vdc	

Y amplitude

17. Adjust the Y gain potentiometer to obtain an output amplitude of 1400mV.

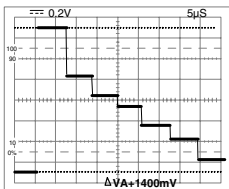
Measure at:	Adjust with:	Required result:	Correct:
X21-14A	ZR528	1400mV	

18. Switch off power and return encoder board to its position in the camera.

Encoder Board NTSC

Set-up

1. Switch off power. Place encoder board on service extender. Genlock camera with black burst signal. Switch on power.
2. Connect oscilloscope via a vectorscope terminated with 75 Ohm to the CVBS output.
3. Switch on colour bar.

Black balance

4. Turn chroma potentiometer R171 on encoder board fully clockwise (max. chroma).
5. Adjust the I and Q balance potentiometers for minimum unbalance in black.

Measure at:	Adjust with:	Required result:	
CVBS out	ZR124 ZR324	Smallest possible dot in centre of vectorscope	

CVBS offset

6. Adjust the CVBS offset potentiometer to place the black bar at 50 mVdc.

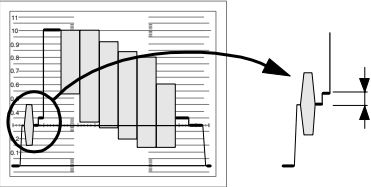
Measure at:	Adjust with:	Required result:	Correct:
CVBS out	ZR529	Black bar = 50mV	

CVBS amplitude

7. Adjust the CVBS gain potentiometer to obtain an output amplitude of 714mV.

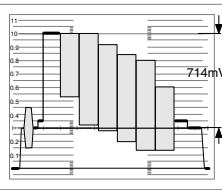
Measure at:	Adjust with:	Required result:	Correct:
CVBS out	R542	714mV	

R-Y amplitude

8. Adjust the R-Y potentiometer to obtain an output amplitude of 1050 mV

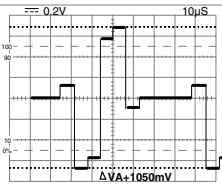
Measure at:	Adjust with:	Required result:	Correct:
X21-8A	R314	1050mV	

Encoder Board NTSC

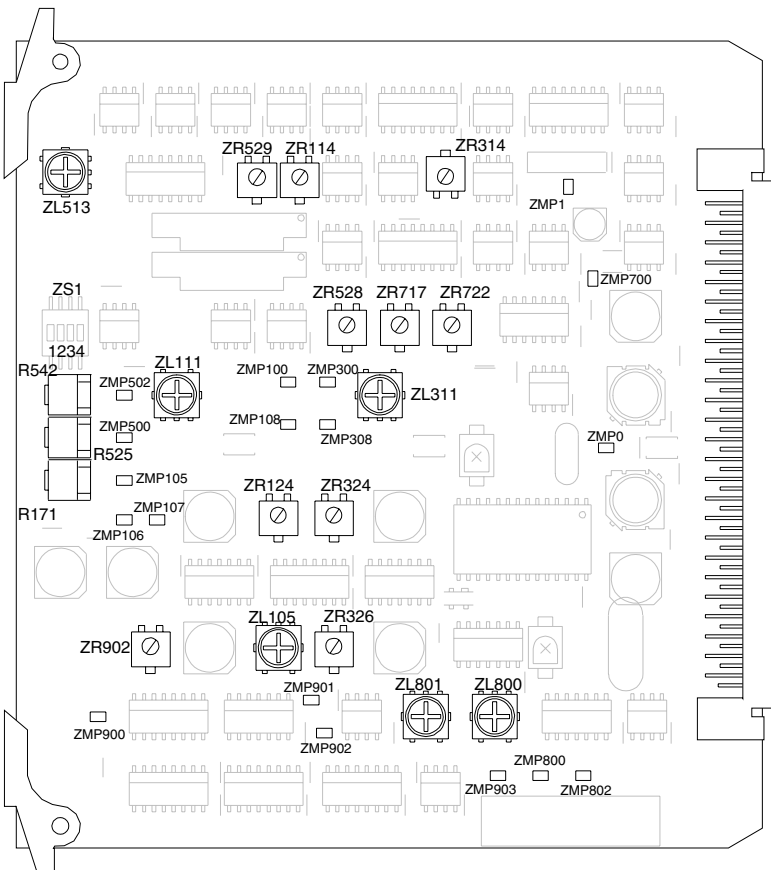
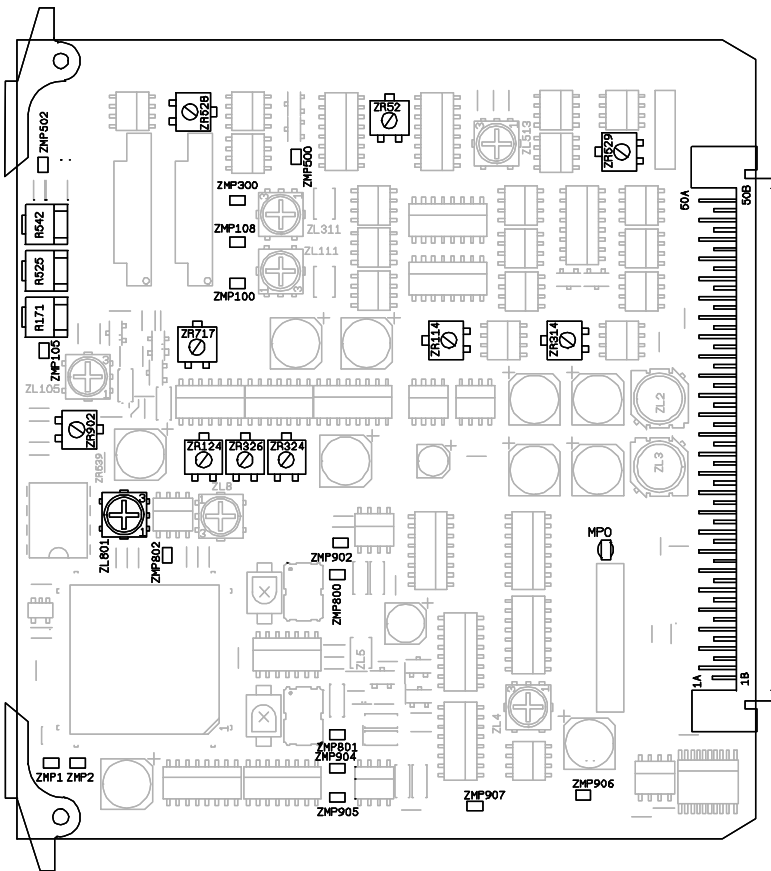

Encoder Board NTSC

B-Y amplitude

9. Adjust the B-Y gain potentiometer to obtain an output amplitude of 1050mV.

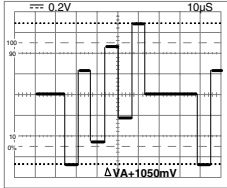
Measure at:	Adjust with:	Required result:	Correct:
X21-11A	ZR114	1050mV	

BURST ADJUSTMENTS

Burst amplitude

10. Adjust the burst amplitude potentiometer to obtain a burst amplitude of 286mV.

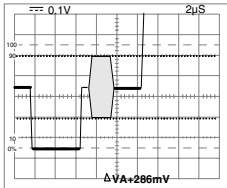
Measure at:	Adjust with:	Required result:	Correct:
CVBS out	ZR717	286mV	

Sc-H phase relationship

11. Switch vectorscope to internal synchronisation.

12. Adjust Sc-H phase potentiometer for 180°.

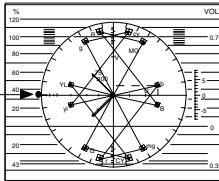
Measure at:	Adjust with:	Required result:	Correct:
CVBS out	ZR902		

Encoder Board NTSC

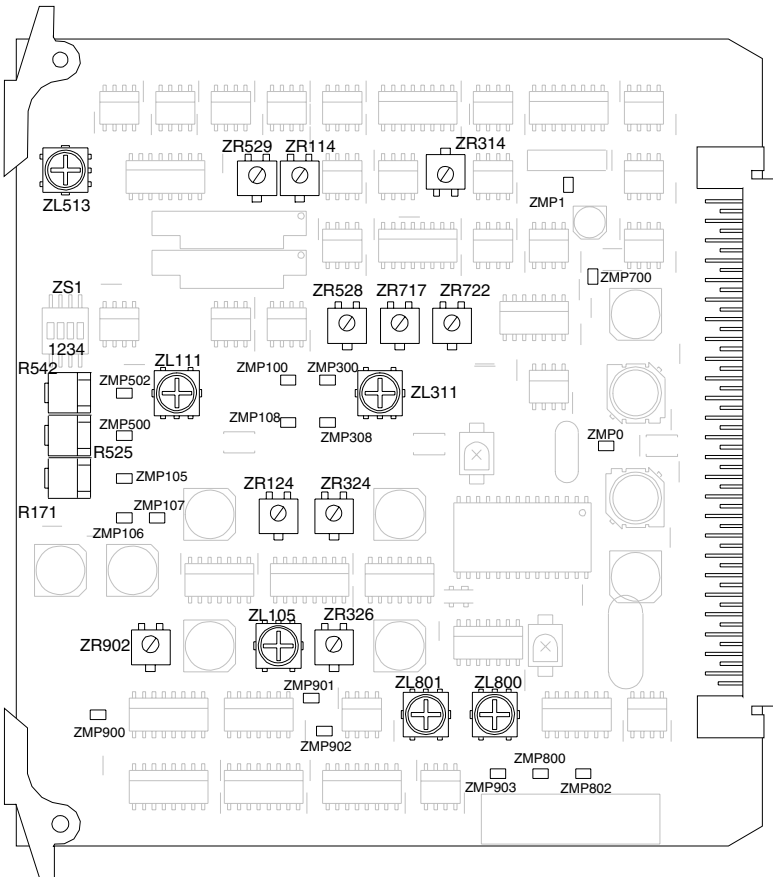
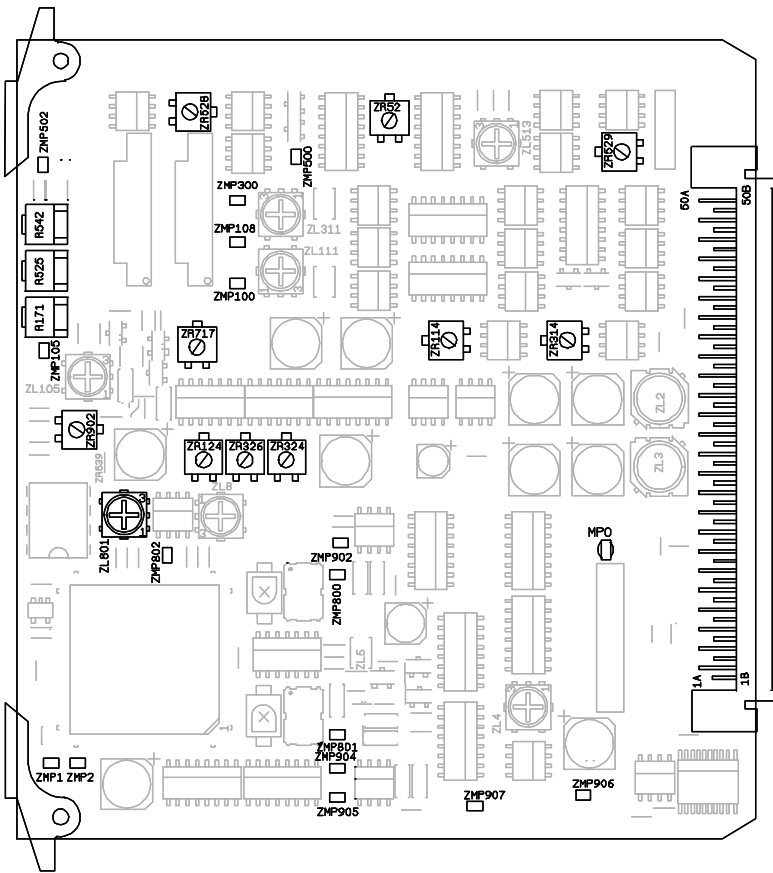

Encoder Board NTSC

Sync amplitude

13. Adjust the sync, amplitude potentiometer fto obtain a sync. ampliature of 286mV.

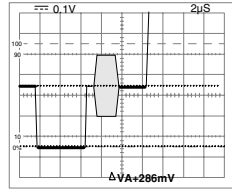
Measure at:	Adjust with:	Required result:	Correct:
CVBS out	ZR525	286mV	

Y offset

14. Adjust the Y offset potentiometer to place the black bar at the 50mVdc level.

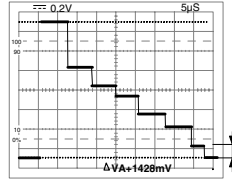
Measure at:	Adjust with:	Required result:	Correct:
X21-14A	ZR52	Black bar = 50mV	

Y amplitude

15. Adjust the Y gain potentiometer to obtain an output amplitude of 1428mV.

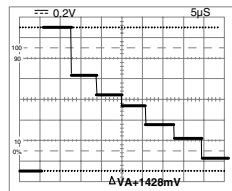
Measure at:	Adjust with:	Required result:	Correct:
X21-14A	ZR528	1428mV	

16. Switch off power and return encoder board to its position in the camera.

Section 5

Wiring Diagrams

Contents

Wiring Diagram Triax adapter	5-2	Wiring Diagram Motherboard Triax	5-5
------------------------------------	-----	--	-----

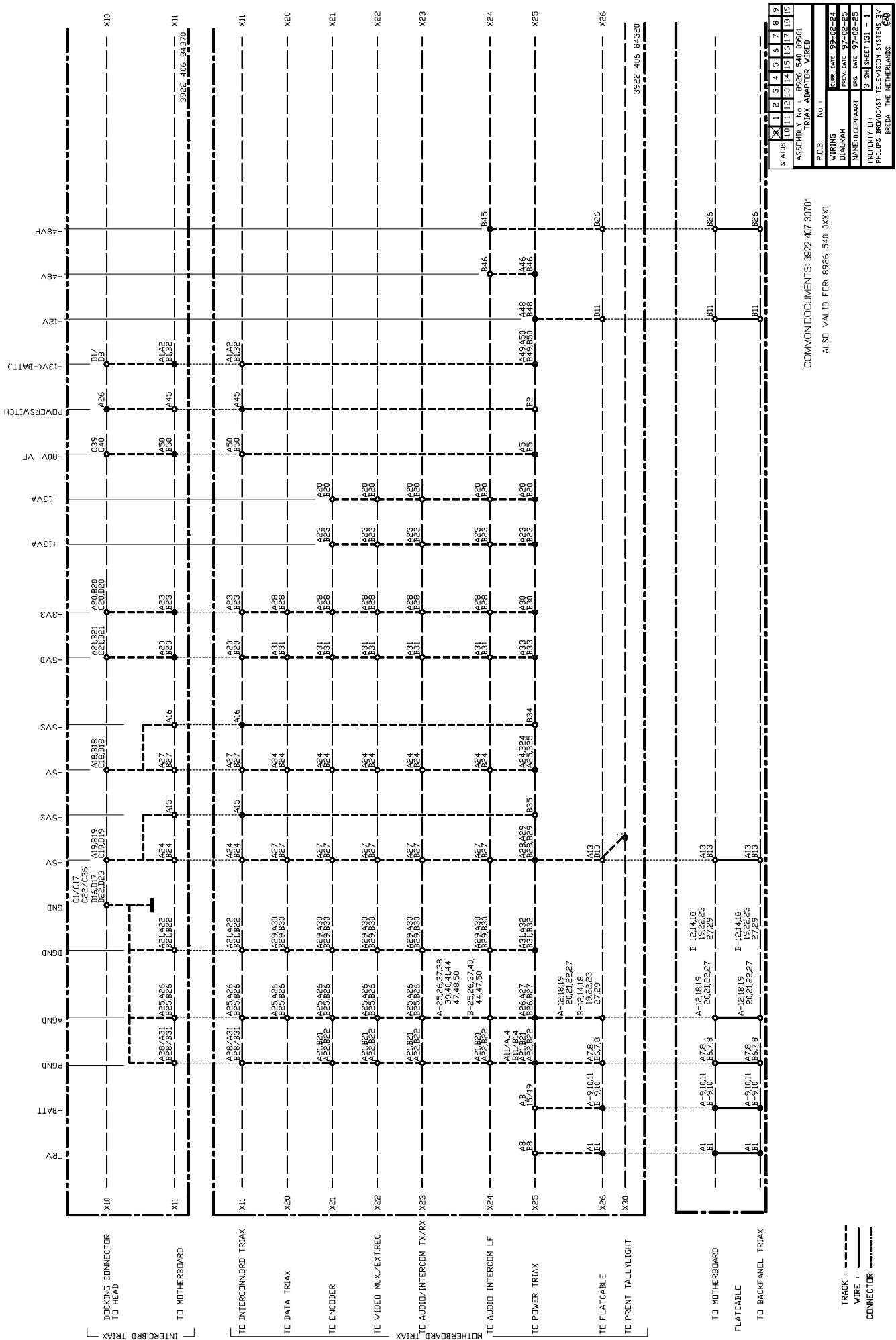

STATUS	X	1	2	3	4	5	6	7	8	9
ASSEMBLY No.	10	11	12	13	14	15	16	17	18	19
P.C.B. No.										
WIRING DIAGRAM										
NAME/DRAWN BY										
DATE										
PROPERTY OF										
PHILIPS BROADCAST TELEVISION SYSTEMS B.V.										
BREDA, THE NETHERLANDS										

COMMON DOCUMENTS: 3922 407 30701
ALSO VALID FOR: 8926 540 00XX1

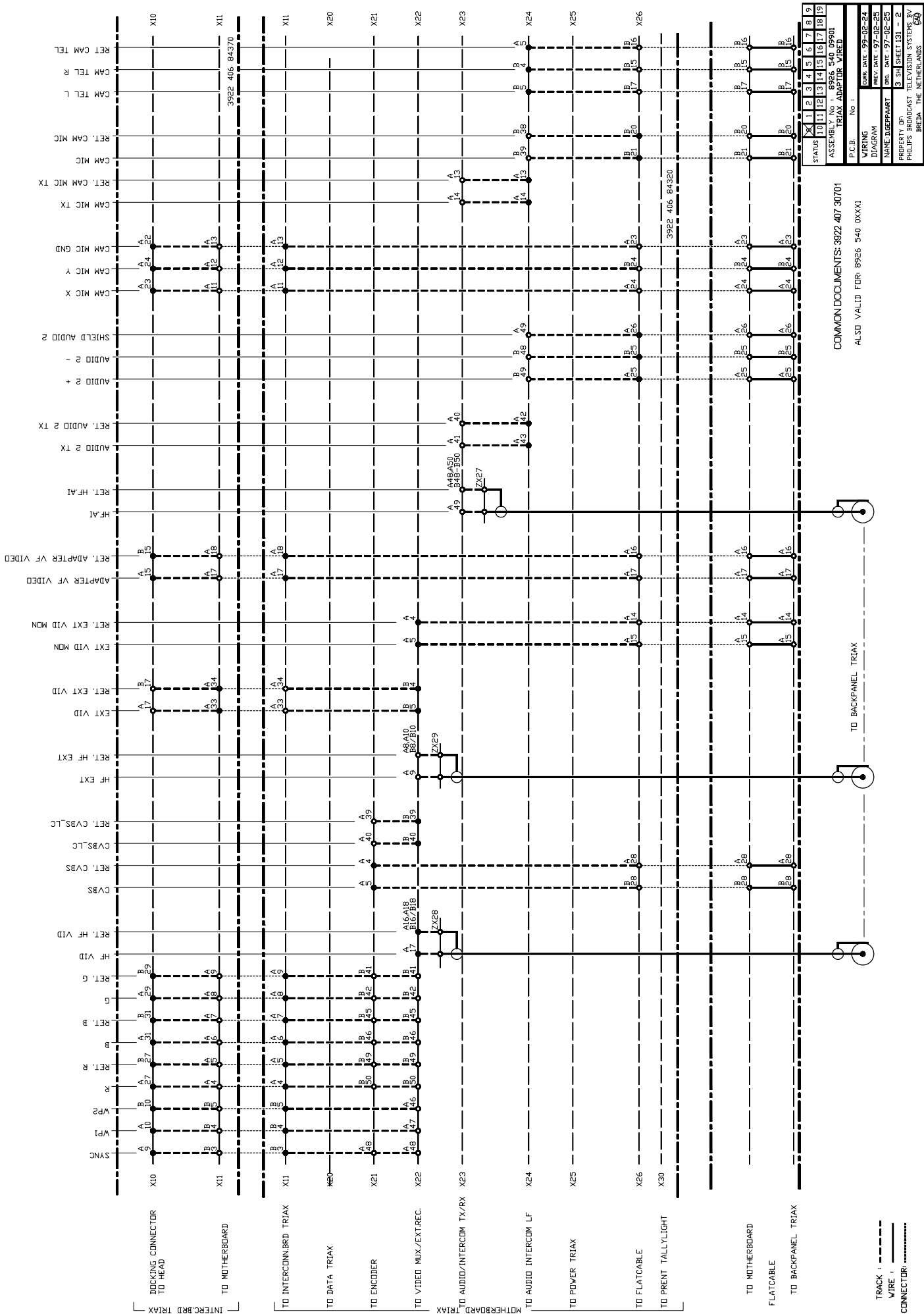

STATUS	X	1	2	3	4	5	6	7	8	9
ASSEMBLY NO	10	11	12	13	14	15	16	17	18	19
TRIAx ADAPTER WIRE										
P.C.B. NO										
WIRING DIAGRAM										
CUR. DATE	99-02-24									
PREV. DATE	97-02-25									
NAME	DEERPAART									
DES. DATE	97-02-25									
PROPERTY OF	3 SH SHEET 131 - 2									
PHILIPS BROADCAST TELEVISION SYSTEMS BV										
BREDA, THE NETHERLANDS										

COMMON DOCUMENTS: 3922 407 30701
ALSO VALID FOR: 8926 540 0XXX1

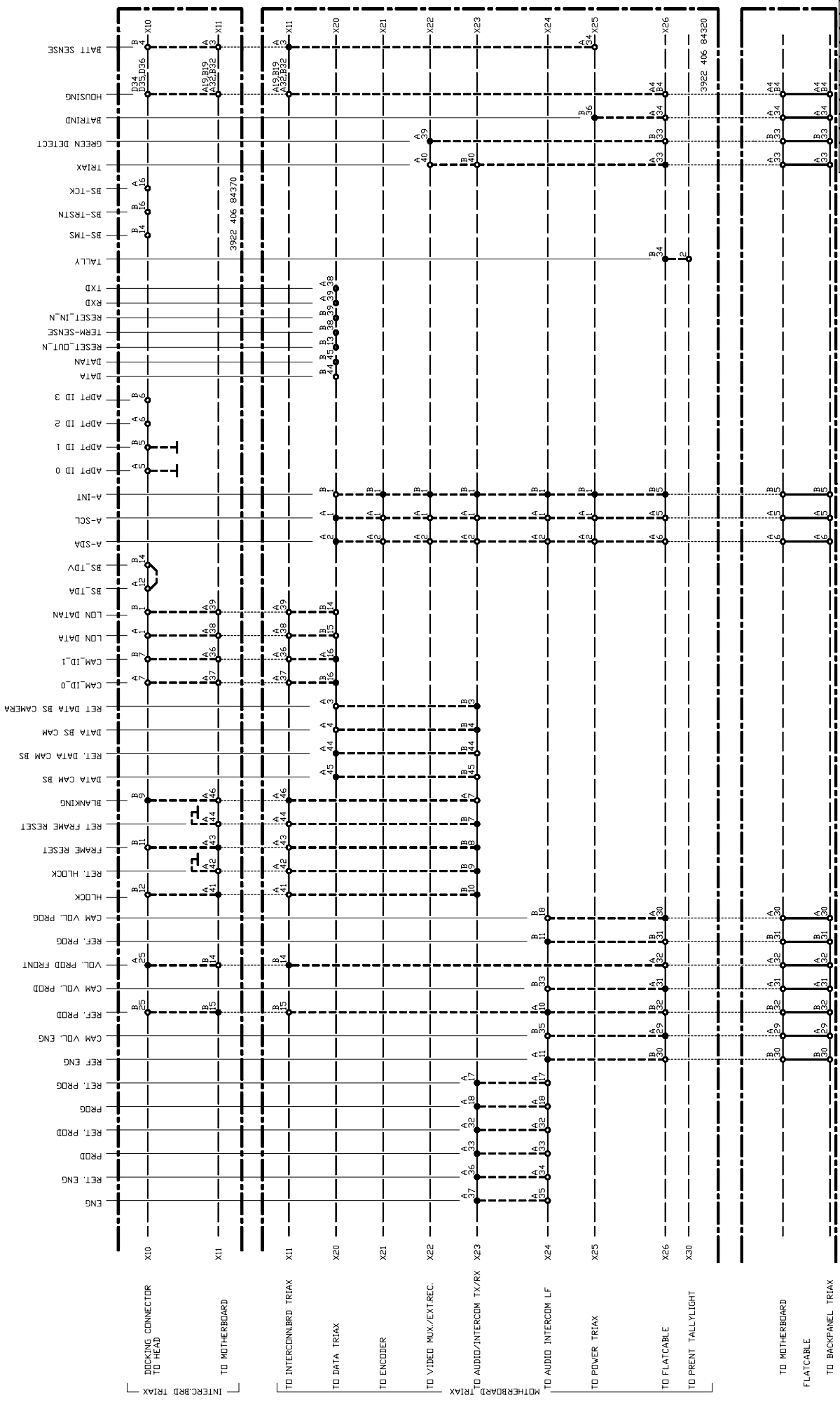

STATUS	X	1	2	3	4	5	6	7	8	9
ASSEMBLY No.	10	11	12	13	14	15	16	17	18	19
ASSEMBLY No.	8926 540 09900									
P.C.B. No.	No. 1									
WIRING DIAGRAM	TRIAx ADAPTOR WIRED									
NAME	DIEPBAART									
REV. DATE	97-02-26									
REV. DATE	97-02-26									
SHEET	3									
SHEET	131 - 3									
PROPERTY OF:	BROADCAST TELEVISION SYSTEMS BY PHILIPS - THE NETHERLANDS									

COMMON DOCUMENTS: 3922 407 30701
 ALSO VALID FOR: 8926 450 0XXX1

TRACK : - - - - -
 WIRE : | | | | |
 CONNECTOR : - - - - -

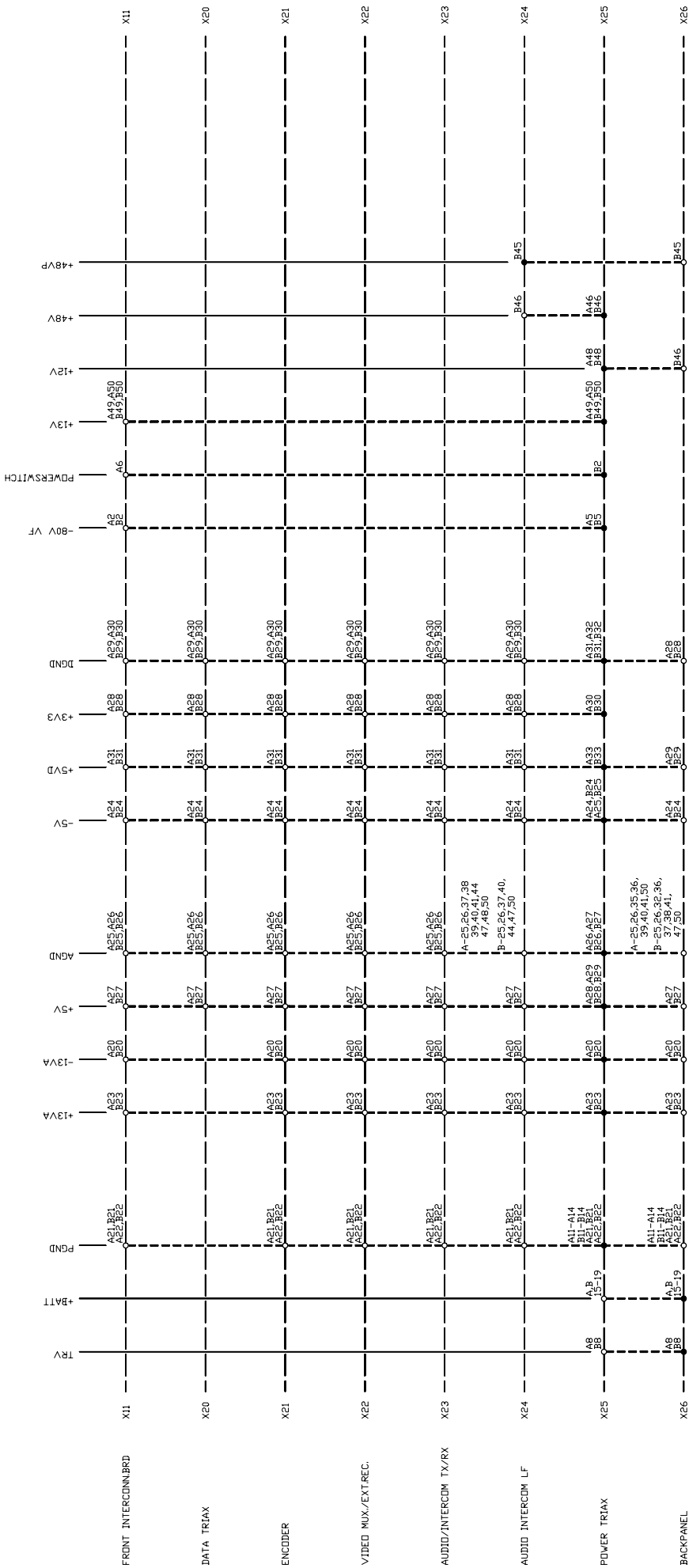

STATUS	10	11	12	13	14	15	16	17	18	19
ASSEMBLY NO.	01	02	03	04	05	06	07	08	09	10
ASSEMBLY DATE	1992-01-24									
ASSEMBLER	PHILIPS BROADCAST SYSTEMS B.V.									
P.C.B.	No 1 3922 411 84321									
WIRING DIAGRAM	REV. DATE: 01-08-24									
NAME	DIEPPAART									
PROPERTY OF	3 SH SHEET 131 - 1									
PHILIPS BROADCAST TELEVISION SYSTEMS B.V.										
BREDA, THE NETHERLANDS										

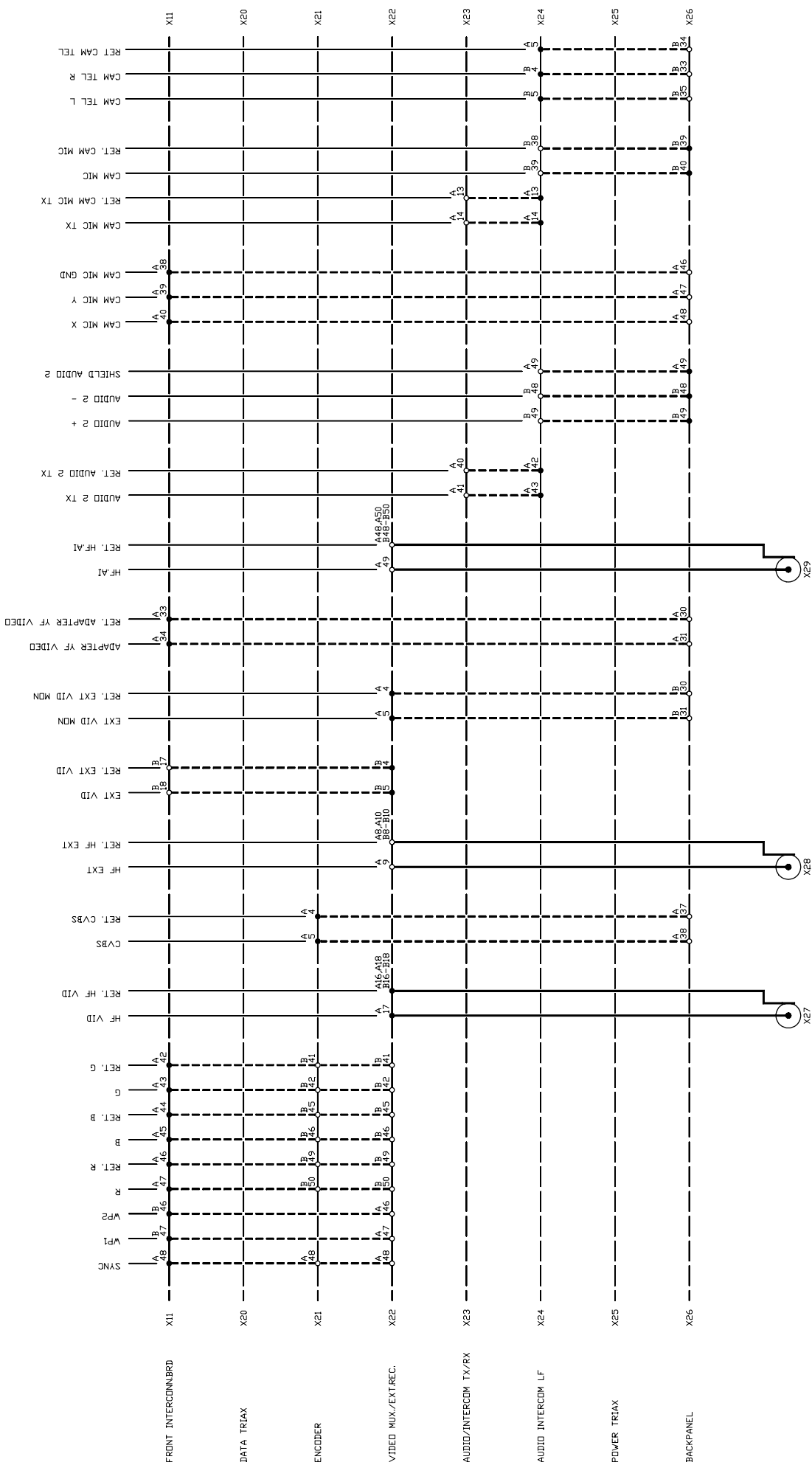

STATUS	7	8	9
ASSEMBLY No. 1	10	11	12
ASSEMBLY No. 2	13	14	15
ASSEMBLY No. 3	16	17	18
ASSEMBLY No. 4	19	20	21
ASSEMBLY No. 5	22	23	24
ASSEMBLY No. 6	25	26	27
ASSEMBLY No. 7	28	29	30
ASSEMBLY No. 8	31	32	33
ASSEMBLY No. 9	34	35	36
ASSEMBLY No. 10	37	38	39
ASSEMBLY No. 11	40	41	42
ASSEMBLY No. 12	43	44	45
ASSEMBLY No. 13	46	47	48
ASSEMBLY No. 14	49	50	51
ASSEMBLY No. 15	52	53	54
ASSEMBLY No. 16	55	56	57
ASSEMBLY No. 17	58	59	60
ASSEMBLY No. 18	61	62	63
ASSEMBLY No. 19	64	65	66
ASSEMBLY No. 20	67	68	69
ASSEMBLY No. 21	70	71	72
ASSEMBLY No. 22	73	74	75
ASSEMBLY No. 23	76	77	78
ASSEMBLY No. 24	79	80	81
ASSEMBLY No. 25	82	83	84
ASSEMBLY No. 26	85	86	87
ASSEMBLY No. 27	88	89	90
ASSEMBLY No. 28	91	92	93
ASSEMBLY No. 29	94	95	96
ASSEMBLY No. 30	97	98	99
ASSEMBLY No. 31	100	101	102
ASSEMBLY No. 32	103	104	105
ASSEMBLY No. 33	106	107	108
ASSEMBLY No. 34	109	110	111
ASSEMBLY No. 35	112	113	114
ASSEMBLY No. 36	115	116	117
ASSEMBLY No. 37	118	119	120
ASSEMBLY No. 38	121	122	123
ASSEMBLY No. 39	124	125	126
ASSEMBLY No. 40	127	128	129
ASSEMBLY No. 41	130	131	132
ASSEMBLY No. 42	133	134	135
ASSEMBLY No. 43	136	137	138
ASSEMBLY No. 44	139	140	141
ASSEMBLY No. 45	142	143	144
ASSEMBLY No. 46	145	146	147
ASSEMBLY No. 47	148	149	150
ASSEMBLY No. 48	151	152	153
ASSEMBLY No. 49	154	155	156
ASSEMBLY No. 50	157	158	159
ASSEMBLY No. 51	160	161	162
ASSEMBLY No. 52	163	164	165
ASSEMBLY No. 53	166	167	168
ASSEMBLY No. 54	169	170	171
ASSEMBLY No. 55	172	173	174
ASSEMBLY No. 56	175	176	177
ASSEMBLY No. 57	178	179	180
ASSEMBLY No. 58	181	182	183
ASSEMBLY No. 59	184	185	186
ASSEMBLY No. 60	187	188	189
ASSEMBLY No. 61	190	191	192
ASSEMBLY No. 62	193	194	195
ASSEMBLY No. 63	196	197	198
ASSEMBLY No. 64	199	200	201
ASSEMBLY No. 65	202	203	204
ASSEMBLY No. 66	205	206	207
ASSEMBLY No. 67	208	209	210
ASSEMBLY No. 68	211	212	213
ASSEMBLY No. 69	214	215	216
ASSEMBLY No. 70	217	218	219
ASSEMBLY No. 71	220	221	222
ASSEMBLY No. 72	223	224	225
ASSEMBLY No. 73	226	227	228
ASSEMBLY No. 74	229	230	231
ASSEMBLY No. 75	232	233	234
ASSEMBLY No. 76	235	236	237
ASSEMBLY No. 77	238	239	240
ASSEMBLY No. 78	241	242	243
ASSEMBLY No. 79	244	245	246
ASSEMBLY No. 80	247	248	249
ASSEMBLY No. 81	250	251	252
ASSEMBLY No. 82	253	254	255
ASSEMBLY No. 83	256	257	258
ASSEMBLY No. 84	259	260	261
ASSEMBLY No. 85	262	263	264
ASSEMBLY No. 86	265	266	267
ASSEMBLY No. 87	268	269	270
ASSEMBLY No. 88	271	272	273
ASSEMBLY No. 89	274	275	276
ASSEMBLY No. 90	277	278	279
ASSEMBLY No. 91	280	281	282
ASSEMBLY No. 92	283	284	285
ASSEMBLY No. 93	286	287	288
ASSEMBLY No. 94	289	290	291
ASSEMBLY No. 95	292	293	294
ASSEMBLY No. 96	295	296	297
ASSEMBLY No. 97	298	299	300
ASSEMBLY No. 98	301	302	303
ASSEMBLY No. 99	304	305	306
ASSEMBLY No. 100	307	308	309
ASSEMBLY No. 101	310	311	312
ASSEMBLY No. 102	313	314	315
ASSEMBLY No. 103	316	317	318
ASSEMBLY No. 104	319	320	321
ASSEMBLY No. 105	322	323	324
ASSEMBLY No. 106	325	326	327
ASSEMBLY No. 107	328	329	330
ASSEMBLY No. 108	331	332	333
ASSEMBLY No. 109	334	335	336
ASSEMBLY No. 110	337	338	339
ASSEMBLY No. 111	340	341	342
ASSEMBLY No. 112	343	344	345
ASSEMBLY No. 113	346	347	348
ASSEMBLY No. 114	349	350	351
ASSEMBLY No. 115	352	353	354
ASSEMBLY No. 116	355	356	357
ASSEMBLY No. 117	358	359	360
ASSEMBLY No. 118	361	362	363
ASSEMBLY No. 119	364	365	366
ASSEMBLY No. 120	367	368	369
ASSEMBLY No. 121	370	371	372
ASSEMBLY No. 122	373	374	375
ASSEMBLY No. 123	376	377	378
ASSEMBLY No. 124	379	380	381
ASSEMBLY No. 125	382	383	384
ASSEMBLY No. 126	385	386	387
ASSEMBLY No. 127	388	389	390
ASSEMBLY No. 128	391	392	393
ASSEMBLY No. 129	394	395	396
ASSEMBLY No. 130	397	398	399
ASSEMBLY No. 131	400	401	402
ASSEMBLY No. 132	403	404	405
ASSEMBLY No. 133	406	407	408
ASSEMBLY No. 134	409	410	411
ASSEMBLY No. 135	412	413	414
ASSEMBLY No. 136	415	416	417
ASSEMBLY No. 137	418	419	420
ASSEMBLY No. 138	421	422	423
ASSEMBLY No. 139	424	425	426
ASSEMBLY No. 140	427	428	429
ASSEMBLY No. 141	430	431	432
ASSEMBLY No. 142	433	434	435
ASSEMBLY No. 143	436	437	438
ASSEMBLY No. 144	439	440	441
ASSEMBLY No. 145	442	443	444
ASSEMBLY No. 146	445	446	447
ASSEMBLY No. 147	448	449	450
ASSEMBLY No. 148	451	452	453
ASSEMBLY No. 149	454	455	456
ASSEMBLY No. 150	457	458	459
ASSEMBLY No. 151	460	461	462
ASSEMBLY No. 152	463	464	465
ASSEMBLY No. 153	466	467	468
ASSEMBLY No. 154	469	470	471
ASSEMBLY No. 155	472	473	474
ASSEMBLY No. 156	475	476	477
ASSEMBLY No. 157	478	479	480
ASSEMBLY No. 158	481	482	483
ASSEMBLY No. 159	484	485	486
ASSEMBLY No. 160	487	488	489
ASSEMBLY No. 161	490	491	492
ASSEMBLY No. 162	493	494	495
ASSEMBLY No. 163	496	497	498
ASSEMBLY No. 164	499	500	501
ASSEMBLY No. 165	502	503	504
ASSEMBLY No. 166	505	506	507
ASSEMBLY No. 167	508	509	510
ASSEMBLY No. 168	511	512	513
ASSEMBLY No. 169	514	515	516
ASSEMBLY No. 170	517	518	519
ASSEMBLY No. 171	520	521	522
ASSEMBLY No. 172	523	524	525
ASSEMBLY No. 173	526	527	528
ASSEMBLY No. 174	529	530	531
ASSEMBLY No. 175	532	533	534
ASSEMBLY No. 176	535	536	537
ASSEMBLY No. 177	538	539	540
ASSEMBLY No. 178	541	542	543
ASSEMBLY No. 179	544	545	546
ASSEMBLY No. 180	547	548	549
ASSEMBLY No. 181	550	551	552
ASSEMBLY No. 182	553	554	555
ASSEMBLY No. 183	556	557	558
ASSEMBLY No. 184	559	560	561
ASSEMBLY No. 185	562	563	564
ASSEMBLY No. 186	565	566	567
ASSEMBLY No. 187	568	569	570
ASSEMBLY No. 188	571	572	573
ASSEMBLY No. 189	574	575	576
ASSEMBLY No. 190	577	578	579
ASSEMBLY No. 191	580	581	582
ASSEMBLY No. 192	583	584	585
ASSEMBLY No. 193	586	587	588
ASSEMBLY No. 194	589	590	591
ASSEMBLY No. 195	592	593	594
ASSEMBLY No. 196	595	596	597
ASSEMBLY No. 197	598	599	600
ASSEMBLY No. 198	601	602	603
ASSEMBLY No. 199	604	605	606
ASSEMBLY No. 200	607	608	609
ASSEMBLY No. 201	610	611	612
ASSEMBLY No. 202	613	614	615
ASSEMBLY No. 203	616	617	618
ASSEMBLY No. 204	619	620	621
ASSEMBLY No. 205	622	623	624
ASSEMBLY No. 206	625	626	627
ASSEMBLY No. 207	628	629	630
ASSEMBLY No. 208	631	632	633
ASSEMBLY No. 209	634	635	636
ASSEMBLY No. 210	637	638	639
ASSEMBLY No. 211	640	641	642
ASSEMBLY No. 212	643	644	645
ASSEMBLY No. 213	646	647	648
ASSEMBLY No. 214	649	650	651
ASSEMBLY No. 215	652	653	654
ASSEMBLY No. 216	655	656	657
ASSEMBLY No. 217	658	659	660
ASSEMBLY No. 218	661	662	663
ASSEMBLY No. 219	664	665	666
ASSEMBLY No. 220	667	668	669
ASSEMBLY No. 221	670	671	672
ASSEMBLY No. 222	673	674	675
ASSEMBLY No. 223	676	677	678
ASSEMBLY No. 224	679	680	681
ASSEMBLY No. 225	682	683	684
ASSEMBLY No. 226	685	686	687
ASSEMBLY No. 227	688	689	690
ASSEMBLY No. 228	691	692	693
ASSEMBLY No. 229	694	695	696
ASSEMBLY No. 230	697	698	699
ASSEMBLY No. 231	700	701	702
ASSEMBLY No. 232	703	704	705
ASSEMBLY No. 233	706	707	708
ASSEMBLY No. 234	709	710	711
ASSEMBLY No. 235	712	713	714
ASSEMBLY No. 236	715	716	717
ASSEMBLY No. 237	718	719	720
ASSEMBLY No. 238	721	722	723
ASSEMBLY No. 239	724	725	726
ASSEMBLY No. 240	727	728	729
ASSEMBLY No. 241	730	731	732
ASSEMBLY No. 242	733	734	735
ASSEMBLY No. 243	736	737	738
ASSEMBLY No. 244	739	740	741
ASSEMBLY No. 245	742	743	744

Section 6

Mechanical Exploded Views

Contents

Triax Adapter	6-2	Triax Adapter Basic	6-3
---------------------	-----	---------------------------	-----

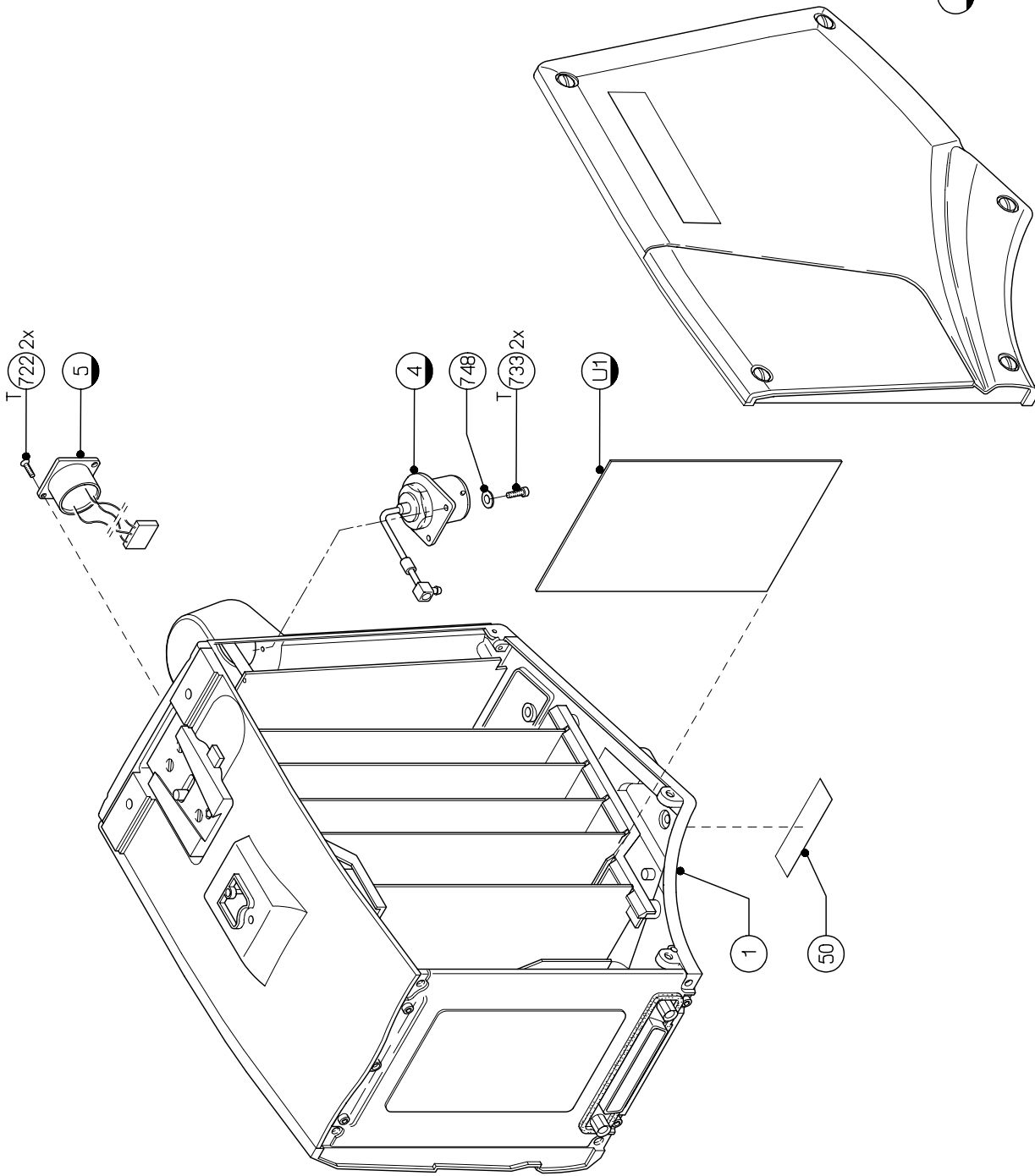

ALSO VALID FOR: 8826 540 0XXX1
 COMMON DOCUMENTS: 3922 407 30701

STATUS	00	10	20	30	40	50	60	70	80	90	99-02-24
	0	1	2	3	4	5	6	7	8	9	
TRIAx ADAPTOR											
MICROFILM											8826 540 08901
NAME (EIGENSCHAFTEN)	SERIES										DATE: 97-07-21
											A3

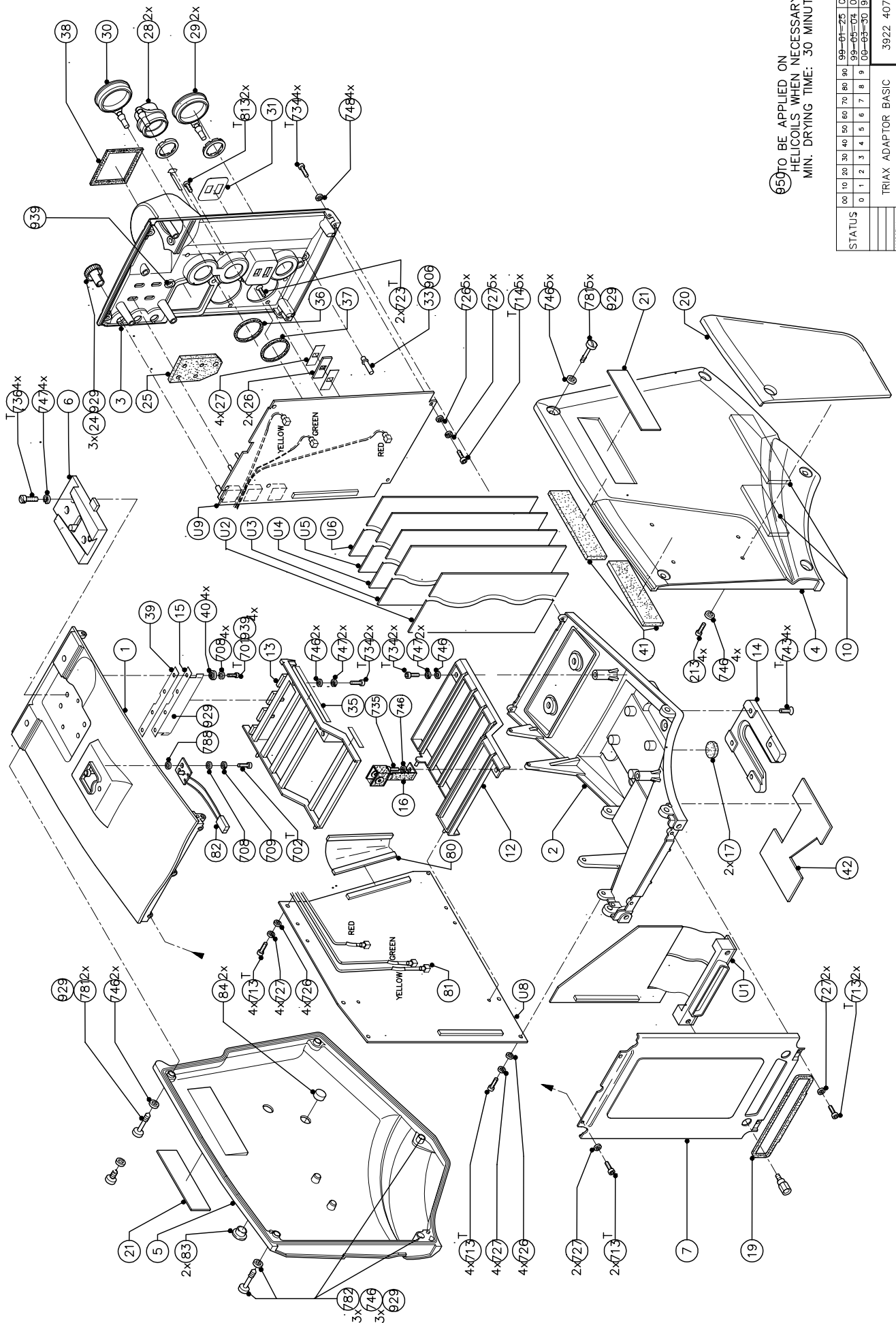

65 TO BE APPLIED ON
 HELICOILS WHEN NECESSARY.
 MIN. DRYING TIME: 30 MINUTES

STATUS	00	10	20	30	40	50	60	70	80	90	99-01-25	00-09-11
	0	1	2	3	4	5	6	7	8	9	99-05-04	01-12-03
											06-05-30	98-01-07
MICROFILM D NAME: Borensbacher SUPERS: SHIP: 110-1 DATE: 97-06-03 A.3 Dr. Property of: THOMSON MULTIMEDIA Broadcast Solutions - THE NETHERLANDS												
TRIAX ADAPTOR BASIC 3922 407 24120												

Section 7

Parts Lists

SERVICE PARTS LIST		
<i>Item</i>	<i>Description</i>	<i>Code Number</i>
000	TECHNICAL MANUAL LDK5400	s 5322 863 00081
00101W	WIRING DIAGRAMS LDK5400	3922 496 49381
00201	TRIAx ADAPTOR PAL FIS/XLR	s 8926 540 00001
00202	TRIAx ADAPTER PAL ARD/XLR	s 8926 540 00501
00203	TRIAx ADAPTER PAL LEMO/XLR	s 8926 540 01001
00204	TRIAx ADAPTOR LEMO 3T/XLR5	s 8926 540 01501
00205	TRIAx ADAPTER PAL FIS/TUCH	s 8926 540 02001
00206	TRIAx ADAPTER PAL ARD/TUCH	s 8926 540 02501
00207	TRIAx ADAPTER PAL LEMO/TUCH	s 8926 540 03001
00208	TRIAx ADAPTOR LEMO 3T/TUCHEL	s 8926 540 03501
00209	TRIAx ADAPTOR BBC LEMO/XLR	s 8926 540 04001
00210	TRIAx ADAPTER NTSC TRIL/XLR	s 8926 540 05001
00211	TRIAx ADAPTER NTSC FIS/XLR	s 8926 540 06001
00213	SET OF ADD.SUPPLIES LDK5400	3922 407 27521
00214	JIGS & TOOLS LDK100 / 200 SERIES	3922 450 04371
00215	TRIAx ADAPTOR BASIC	3922 407 24121

products marked with "s" are available as spare part,
other parts are printed for information only.

TECHNICAL MANUAL LDK5400	ORDERING CODE: 5322 863 00081	STATUS: 03
	REF NR: 3922 496 46791	DATE: 2002-03-15
		SHEET: 1 OF 1

SERVICE PARTS LIST		
<i>Item</i>	<i>Description</i>	<i>Code Number</i>
1	TRIAX ADAPTOR BASIC	3922 407 24121
4	FISHER RECEPTACLE WIRED	s 5322 218 11775
5	SAM INTERCONN. XLR5	s 5322 265 11107
7	NUT DRIVER FISHER PLUG	s 5322 395 10798
8	NUT DRIVER BNC CONNECTOR	s 5322 395 10799
50	TYPEPLATE THOMSON CE	
99	PACKAGE LDK100 CAM EN TRIAXADP	
722T	CSK SCR STL ST M2,5X6	s 5322 502 13917
733T	PAN SCR STL ST M3X6	s 5322 502 14403
748	EARTH WASH STL ST A4 3,2X6	s 5322 532 12257
DIAGRWR	WIRING DIAGRAMS LDK5400	3922 496 49381
JT	JIGS & TOOLS LDK100 / 200 SERIES	3922 450 04371

products market with "s" are available as spare part,
other parts are printed for information only.

TRIAX ADAPTOR PAL FIS/XLR	ORDERING CODE: 8926 540 00001	STATUS:
	REF NR: 8926 540 00001	DATE: 2001-12-05
		SHEET: 1 OF 1

alt. code: LDK5400/00

SERVICE PARTS LIST		
<i>Item</i>	<i>Description</i>	<i>Code Number</i>
1	TRIAX ADAPTOR BASIC	3922 407 24121
4	ARD RECEPTACLE WIRED	s 5322 218 11776
5	SAM INTERCONN. XLR5	s 5322 265 11107
7	NUT DRIVER FISHER PLUG	s 5322 395 10798
8	NUT DRIVER BNC CONNECTOR	s 5322 395 10799
50	TYPEPLATE THOMSON CE	
99	PACKAGE LDK100 CAM EN TRIAXADP	
722T	CSK SCR STL ST A4 M1,6X4	s 5322 502 14047
733T	PAN SCR STL ST M3X6	s 5322 502 14403
748	EARTH WASH STL ST A4 3,2X6	s 5322 532 12257
DIAGRWR	WIRING DIAGRAMS LDK5400	3922 496 49381
JT	JIGS & TOOLS LDK100 / 200 SERIES	3922 450 04371

products market with "s" are available as spare part,
other parts are printed for information only.

TRIAX ADAPTER PAL ARD/XLR	ORDERING CODE: 8926 540 00501	STATUS:
	REF NR: 8926 540 00501	DATE: 2001-12-05
		SHEET: 1 OF 1

alt. code: LDK5400/05

SERVICE PARTS LIST		
<i>Item</i>	<i>Description</i>	<i>Code Number</i>
1	TRIAX ADAPTOR BASIC	3922 407 24121
4	LEMO RECEPTACLE WIRED	s 5322 218 11777
5	SAM INTERCONN. XLR5	s 5322 265 11107
7	NUT DRIVER FISHER PLUG	s 5322 395 10798
8	NUT DRIVER BNC CONNECTOR	s 5322 395 10799
50	TYPEPLATE THOMSON CE	
99	PACKAGE LDK100 CAM EN TRIAXADP	
722T	CSK SCR STL ST M2,5X6	s 5322 502 13917
733T	PAN SCR STL ST M3X6	s 5322 502 14403
748	EARTH WASH STL ST A4 3,2X6	s 5322 532 12257
DIAGRWR	WIRING DIAGRAMS LDK5400	3922 496 49381
JT	JIGS & TOOLS LDK100 / 200 SERIES	3922 450 04371

products market with "s" are available as spare part,
other parts are printed for information only.

TRIAX ADAPTER PAL LEMO/XLR	ORDERING CODE: 8926 540 01001	STATUS:
	REF NR: 8926 540 01001	DATE: 2001-12-05
		SHEET: 1 OF 1

alt. code: LDK5400/10

SERVICE PARTS LIST		
<i>Item</i>	<i>Description</i>	<i>Code Number</i>
1	TRIAX ADAPTOR BASIC	3922 407 24121
4	LEMO 3T RECEPTACLE WIRED	s 3922 407 34471
5	SAM INTERCONN. XLR5	s 5322 265 11107
7	NUT DRIVER FISHER PLUG	s 5322 395 10798
8	NUT DRIVER BNC CONNECTOR	s 5322 395 10799
50	TYPEPLATE THOMSON CE	
99	PACKAGE LDK100 CAM EN TRIAXADP	
722T	CSK SCR STL ST M2,5X6	s 5322 502 13917
733T	PAN SCR STL ST M3X6	s 5322 502 14403
748	EARTH WASH STL ST A4 3,2X6	s 5322 532 12257

products market with "s" are available as spare part,
other parts are printed for information only.

TRIAX ADAPTOR LEMO 3T/XLR5	ORDERING CODE: 8926 540 01501	STATUS:
	REF NR: 8926 540 01501	DATE: 2001-12-05
		SHEET: 1 OF 1

alt. code: LDK5400/15

SERVICE PARTS LIST		
<i>Item</i>	<i>Description</i>	<i>Code Number</i>
1	TRIAX ADAPTOR BASIC	3922 407 24121
4	FISHER RECEPTACLE WIRED	s 5322 218 11775
5	SAM INTERCONN.TUCHEL	s 5322 265 11108
7	NUT DRIVER FISHER PLUG	s 5322 395 10798
8	NUT DRIVER BNC CONNECTOR	s 5322 395 10799
50	TYPEPLATE THOMSON CE	
99	PACKAGE LDK100 CAM EN TRIAXADP	
722T	CSK SCR STL ST A4 M1,6X4	s 5322 502 14047
733T	PAN SCR STL ST M3X6	s 5322 502 14403
748	EARTH WASH STL ST A4 3,2X6	s 5322 532 12257
DIAGRWR	WIRING DIAGRAMS LDK5400	3922 496 49381
JT	JIGS & TOOLS LDK100 / 200 SERIES	3922 450 04371

products market with "s" are available as spare part,
other parts are printed for information only.

TRIAX ADAPTER PAL FIS/TUCH	ORDERING CODE: 8926 540 02001	STATUS:
	REF NR: 8926 540 02001	DATE: 2001-12-05
		SHEET: 1 OF 1

alt. code: LDK5400/20

SERVICE PARTS LIST		
<i>Item</i>	<i>Description</i>	<i>Code Number</i>
1	TRIAx ADAPTOR BASIC	3922 407 24121
4	ARD RECEPTACLE WIRED	s 5322 218 11776
5	SAM INTERCONN.TUCHEL	s 5322 265 11108
7	NUT DRIVER FISHER PLUG	s 5322 395 10798
8	NUT DRIVER BNC CONNECTOR	s 5322 395 10799
50	TYPEPLATE THOMSON CE	
99	PACKAGE LDK100 CAM EN TRIAXADP	
722T	CSK SCR STL ST A4 M1,6X4	s 5322 502 14047
733T	PAN SCR STL ST M3X6	s 5322 502 14403
748	EARTH WASH STL ST A4 3,2X6	s 5322 532 12257
DIAGRWR	WIRING DIAGRAMS LDK5400	3922 496 49381
JT	JIGS & TOOLS LDK100 / 200 SERIES	3922 450 04371

products market with "s" are available as spare part,
other parts are printed for information only.

TRIAx ADAPTER PAL ARD/TUCH	ORDERING CODE: 8926 540 02501	STATUS:
	REF NR: 8926 540 02501	DATE: 2001-12-05
		SHEET: 1 OF 1

alt. code: LDK5400/25

SERVICE PARTS LIST		
<i>Item</i>	<i>Description</i>	<i>Code Number</i>
1	TRIAX ADAPTOR BASIC	3922 407 24121
4	LEMO RECEPTACLE WIRED	s 5322 218 11777
5	SAM INTERCONN.TUCHEL	s 5322 265 11108
7	NUT DRIVER FISHER PLUG	s 5322 395 10798
8	NUT DRIVER BNC CONNECTOR	s 5322 395 10799
50	TYPEPLATE THOMSON CE	
99	PACKAGE LDK100 CAM EN TRIAXADP	
722T	CSK SCR STL ST A4 M1,6X4	s 5322 502 14047
733T	PAN SCR STL ST M3X6	s 5322 502 14403
748	EARTH WASH STL ST A4 3,2X6	s 5322 532 12257
DIAGRWR	WIRING DIAGRAMS LDK5400	3922 496 49381
JT	JIGS & TOOLS LDK100 / 200 SERIES	3922 450 04371

products market with "s" are available as spare part,
other parts are printed for information only.

TRIAX ADAPTER PAL LEMO/TUCH	ORDERING CODE: 8926 540 03001	STATUS:
	REF NR: 8926 540 03001	DATE: 2001-12-05
		SHEET: 1 OF 1

alt. code: LDK5400/30

SERVICE PARTS LIST		
<i>Item</i>	<i>Description</i>	<i>Code Number</i>
1	TRIAX ADAPTOR BASIC	3922 407 24121
4	LEMO 3T RECEPTACLE WIRED	s 3922 407 34471
5	SAM INTERCONN.TUCHEL	s 5322 265 11108
7	NUT DRIVER FISHER PLUG	s 5322 395 10798
8	NUT DRIVER BNC CONNECTOR	s 5322 395 10799
50	TYPEPLATE THOMSON CE	
99	PACKAGE LDK100 CAM EN TRIAXADP	
722T	CSK SCR STL ST M2,5X6	s 5322 502 13917
733T	PAN SCR STL ST M3X6	s 5322 502 14403
748	EARTH WASH STL ST A4 3,2X6	s 5322 532 12257

products market with "s" are available as spare part,
other parts are printed for information only.

TRIAX ADAPTOR LEMO 3T/TUCHEL	ORDERING CODE: 8926 540 03501	STATUS:
	REF NR: 8926 540 03501	DATE: 2001-12-05
		SHEET: 1 OF 1

alt. code: LDK5400/35

SERVICE PARTS LIST		
<i>Item</i>	<i>Description</i>	<i>Code Number</i>
1	TRIAX ADAPTOR BASIC	3922 407 24121
4	BBC LEMO RECEPTACLE WIRED	s 5322 218 11774
5	SAM INTERCONN. XLR5	s 5322 265 11107
7	NUT DRIVER FISHER PLUG	s 5322 395 10798
8	NUT DRIVER BNC CONNECTOR	s 5322 395 10799
50	TYPEPLATE THOMSON CE	
99	PACKAGE LDK100 CAM EN TRIAXADP	
722T	CSK SCR STL ST A4 M1,6X4	s 5322 502 14047
733T	PAN SCR STL ST M3X6	s 5322 502 14403
748	EARTH WASH STL ST A4 3,2X6	s 5322 532 12257

products market with "s" are available as spare part,
other parts are printed for information only.

TRIAX ADAPTOR BBC LEMO/XLR	ORDERING CODE: 8926 540 04001	STATUS:
	REF NR: 8926 540 04001	DATE: 2001-12-05
		SHEET: 1 OF 1

alt. code: LDK5400/40

SERVICE PARTS LIST		
<i>Item</i>	<i>Description</i>	<i>Code Number</i>
1	TRIAx ADAPTOR BASIC	3922 407 24121
4	TRILOCK RECEPTACLE WIRED	s 5322 218 11778
5	SAM INTERCONN. XLR5	s 5322 265 11107
7	NUT DRIVER FISHER PLUG	s 5322 395 10798
8	NUT DRIVER BNC CONNECTOR	s 5322 395 10799
50	TYPEPLATE THOMSON CE	
99	PACKAGE LDK100 CAM EN TRIAXADP	
722T	CSK SCR STL ST A4 M1,6X4	s 5322 502 14047
733T	PAN SCR STL ST M3X6	s 5322 502 14403
748	EARTH WASH STL ST A4 3,2X6	s 5322 532 12257
DIAGRWR	WIRING DIAGRAMS LDK5400	3922 496 49381
JT	JIGS & TOOLS LDK100 / 200 SERIES	3922 450 04371

products marked with "s" are available as spare part,
other parts are printed for information only.

TRIAx ADAPTER NTSC TRIL/XLR	ORDERING CODE: 8926 540 05001	STATUS:
	REF NR: 8926 540 05001	DATE: 2001-12-05
		SHEET: 1 OF 1

alt. code: LDK5400/50

SERVICE PARTS LIST		
<i>Item</i>	<i>Description</i>	<i>Code Number</i>
1	TRIAx ADAPTOR BASIC	3922 407 24121
4	FISHER RECEPTACLE WIRED	s 5322 218 11775
5	SAM INTERCONN. XLR5	s 5322 265 11107
7	NUT DRIVER FISHER PLUG	s 5322 395 10798
8	NUT DRIVER BNC CONNECTOR	s 5322 395 10799
50	TYPEPLATE THOMSON CE	
99	PACKAGE LDK100 CAM EN TRIAXADP	
722T	CSK SCR STL ST M2,5X6	s 5322 502 13917
733T	PAN SCR STL ST M3X6	s 5322 502 14403
748	EARTH WASH STL ST A4 3,2X6	s 5322 532 12257
DIAGRWR	WIRING DIAGRAMS LDK5400	3922 496 49381
JT	JIGS & TOOLS LDK100 / 200 SERIES	3922 450 04371

products marked with "s" are available as spare part,
other parts are printed for information only.

TRIAx ADAPTER NTSC FIS/XLR	ORDERING CODE: 8926 540 06001	STATUS:
	REF NR: 8926 540 06001	DATE: 2001-12-05
		SHEET: 1 OF 1

alt. code: LDK5400/60

SERVICE PARTS LIST		
<i>Item</i>	<i>Description</i>	<i>Code Number</i>
1	OPERATOR'S MANUAL LDK5400	s 5322 863 00079
2	TECHNICAL MANUAL LDK5400	s 5322 863 00081
2D	SERVICE MANUAL LDK5400	s 3922 496 46801
3	SET CAMERACIPHERS MIDDLE	
4	BAG PE 250X410X0,03	s 5322 600 10768

products market with "s" are available as spare part,
other parts are printed for information only.

SET OF ADD.SUPPLIES LDK5400	ORDERING CODE: not a spare part	STATUS:
	REF NR: 3922 407 27521	DATE: 1999-06-23
		SHEET: 1 OF 1

SERVICE PARTS LIST		
<i>Item</i>	<i>Description</i>	<i>Code Number</i>
1	PCB EXTENDER SMALL	s 5322 466 11795
2	EXTENDER LARGE	s 5322 466 11796
3	MECHANICAL FRONT EXTENDER	s 5322 402 10927
4	TRIPOD ADAPTER PLATE LDK5031	8926 503 10001
45B	HELICOL M3-1D	s 5322 417 11369

products market with "s" are available as spare part,
other parts are printed for information only.

JIGS & TOOLS LDK100 / 200 SERIES	ORDERING CODE: not a spare part	STATUS:
	REF NR: 3922 450 04371	DATE: 2001-02-09
		SHEET: 1 OF 1

SERVICE PARTS LIST						
Item	Description		Code Number	Item	Description	Code Number
1	TOPPLATE TRIAX	s	5322 442 01136	746	WASH STL ST 3,2X7	s 5322 532 12126
2	BOTTOMPLATE MACHINED AND LACQ	s	5322 442 01137	747	SPR WASH STL ST 3,1X5,7	s 4822 530 80188
3	BACKPLATE MACHINED AND LACQUE	s	5322 426 10543	748	EARTH WASH STL ST A4 3,2X6	s 5322 532 12257
4	COVER LEFT	s	5322 426 10544	781	RSD CH NK SCR STL ST M3X10 RVS	s 5322 502 13956
5	COVER RIGHT MACHINED AND LACQ	s	5322 426 10545	782	RSD CH NK SCR STL ST M3X12	s 5322 502 13913
6	QUICK MOUNT BLOCK ASSY	s	5322 466 11712	788	WASH PF-CP SH 3,2X7	s 2522 600 28017
7	DOCKPLATE ADAPTOR	s	5322 466 11713	813	PAN TAP SCR F ST T8 2,9X8	s 5322 502 14044
10	CEL RUBBER ZK/CR FEST 10X4MM			906	RUBBER GLUE SYNTHETIC NBR 042	
12	PRINTRAIL BOTTOM	s	3922 400 08594	929	GREASE FS 1292	
13	PRINTRAIL TOP	s	5322 463 11162	939	SCREW LOCK 222	
14	V BRACKET LONG	s	5322 402 10879	950	LOCKTITE 480	
15	COOLING BRACKET	s	5322 255 10391	U1	INTERCON BOARD TRIAX	s 5322 214 12524
16	INTERCONN.FLEX BRACKET	s	3922 407 32931	U2	DATA BOARD	s 5322 214 12525
17	FOOT	s	5322 462 10994	U3	VIDEO MUX/EXT REC.	s 5322 214 12526
19	SEALING DOCKPLATE	s	5322 466 11714	U4	AUDIO INT TX/REC	s 5322 214 12527
20	PADDING TRIAX-ADAPTOR	s	5322 466 11715	U5	AUDIO INTERC LF	s 5322 214 12528
21	WORDMARK 62MM	s	5322 454 13247	U6	POWER BOARD	s 5322 214 12529
24	LONG KNOB	s	5322 410 11459	U8	MOTHERBOARD TRIAX	s 5322 214 12531
25	GASKET 5-FOLD	s	5322 466 11716	U9	TRIAX BACKPANEL	s 3922 406 89481
26	GASKET FOR SLIDESWITCH	s	5322 466 11717			
27	SHEET FOR SLIDESWITCH	s	5322 466 11718			
28	DUSTCOVER BNC	s	5322 462 10995			
29	DUSTCOVER FISCHER/XLR3-M	s	5322 462 10996			
30	DUSTCOVER XLR3 FEMALE	s	5322 462 10997			
31	TEXTSTICKER ON BACKPANEL					
33	POWER-ON LENS	s	5322 381 11926			
35	LABEL PRINTRAIL					
36	GASKET XLR3	s	5322 466 11719			
37	GASKET XLR4	s	5322 466 11721			
38	GASKET HEADSET	s	5322 466 11722			
39	ISOLATION PLATE	s	5322 466 11891			
40	ISOLATION BUSH	s	5322 532 12984			
41	CR STRIP 10X2MM SELFADH					
42	STICKER X130	s	5322 454 13355			
80	ASSY FLETicable 68P	s	5322 320 12165			
81	COAXCABLE ASSY TRIAX ADAPTOR	s	5322 322 10125			
82	TALLY LIGHT ASSY	s	5322 320 12166			
83	BUSH	s	5322 532 11116			
84	CAP	s	5322 462 50289			
85	SET OF ADD.SUPPLIES LDK5400		3922 407 27521			
90	SET OF SOFTWARE LDK5400	s	3922 407 25051			
93	SERVICE ASSY FLATCABLE 68P	s	5322 320 12165			
213	PAN TAP SCR F ST T8 2,9X6,5	s	5322 502 14037			
701T	PAN SCR STL ST M2X4	s	5322 502 14492			
702T	PAN SCR STL ST M2X6	s	5322 502 14494			
708	WASH STL ST 2,2X5	s	5322 532 12139			
709	SPR WASH STL ST 2,1X4.4	s	5322 530 84092			
713T	PAN SCR STL ST M2,5X6	s	5322 502 21207			
714T	PAN SCR STL ST M2,5X8	s	5322 502 21208			
723	CSK SCR STL ST M2,5X8	s	5322 502 21201			
726	WASH STL ST 2,7X6,5	s	5322 532 12128			
727	SPR WASH STL ST 2,6X5,1	s	5322 530 80656			
734T	PAN SCR STL ST M3X8	s	5322 502 14405			
736T	PAN SCR STL ST M3X12	s	5322 502 21213			
743T	CSK SCR STL ST M3X8	s	4822 502 13964			

products marked with "s" are available as spare part,
other parts are printed for information only.

TRIAx ADAPTOR BASIC	ORDERING CODE: not a spare part	STATUS:
	REF NR: 3922 407 24121	DATE: 2001-12-11
		SHEET: 1 OF 1